

**SUPCO**

**International**

**Vol.37**

## About Sudco...

Sudco International is one of America's oldest and largest importer/ distributor of motorcycle replacement parts and high performance accessories. For decades we have provided dealers with the best available parts and services so they can serve their customers even better. We will continue to do this now and into the future, thanks to your continued support in allowing us to provide you the high quality parts you need. Please do not hesitate to call on us should you have any particular needs, problems or questions.. We will do everything we can to make sure Sudco remains one of your main sources for quality replacement parts and accessories.

Sudco International is a major importer and distributor in America for top brand replacement parts, many of which are from the original equipment manufacturers that provide the OEM parts to the major Japanese and European manufacturers. Our product line includes quality products from Keihin, Mikuni, ART, JE, NGK, Vesrah, RK, Sunstar, Nology, Dyateck, Pingel, K&N, Motion Pro and others.

Some of the products in our Sudco Catalog are sold for Off-Road and Racing Use Only and as such are not legal for use on vehicles operated on public highways and in locations where such laws may apply. These products include Aftermarket Carburetors and Carburetor Kits, Replacement Carburetor Jetting, Fuel Injection and Ignition Tuning Modules, and Aftermarket Exhaust Systems. Please contact us should you have any questions regarding the legality of non-original replacement parts



PLEASE FILL OUT AND RETURN TO ACHIEVE ACCOUNT STATUS

PLEASE ATTACH BOTH OF THE FOLLOWING:

- COPY OF STATE RESALE LICENSE (ATTACH COPY)
- COPY OF THE STATE MOTOR VEHICLE SELLERS REGISTRATION LICENSE OR BUSINESS LICENSE
- FOR CALIFORNIA SIGNED RESALE CERTIFICATE, OR SALES TAX WILL BE CHARGED

AND PLEASE ATTACH ONE OF THE FOLLOWING:

- Copy of Advertisement
- Copy of YellowPage Ad
- Storefront Photo

- Type of Business:**
- Dealer/Retailer
  - Service/Repair
  - Distributor
  - Parts/Accessories
  - Importer/Exporter
  - Manufacturer

- Market Categories:**  
(check all that apply)
- ATV
  - Drag
  - Performance
  - Touring
  - American Big Twin
  - Dual Sport
  - Scooter
  - Vintage
  - Cruiser
  - Extreme
  - Snowmobile
  - Watercraft
  - Dirt Bikes
  - Karting
  - Street Bikes

- Franchises:**
- BMW
  - Harley-Davidson
  - Norton
  - BSA
  - Honda
  - Suzuki
  - Buell
  - Kawasaki
  - Triumph
  - Ducati
  - KTM
  - Yamaha
  - Other \_\_\_\_\_

**Business Name:** \_\_\_\_\_

**Address:** \_\_\_\_\_  
\_\_\_\_\_

**Phone Number:** \_\_\_\_\_ **Fax Number:** \_\_\_\_\_

**E-mail:** \_\_\_\_\_

**Company Bank:** \_\_\_\_\_

**Address:** \_\_\_\_\_

**Phone Number:** \_\_\_\_\_ **Bank Official (if known):** \_\_\_\_\_

**Owner's Name:** \_\_\_\_\_

**Buyer's Name:** \_\_\_\_\_

**Years In Business:** \_\_\_\_\_ **Number of Employees:** \_\_\_\_\_ **Gross Sales:** \_\_\_\_\_

**WHEN APPROVED AS ONE OF SUDCO CUSTOMERS, INITIAL ORDERS ARE SENT C.O.D/CASH ONLY UNLESS PRIOR ARRANGEMENTS HAVE BEEN MADE. UPON RECEIPT OF YOUR BANK REFERENCE, FUTURE ORDERS WILL BE SENT C.O.D., COMPANY CHECK ACCEPTABLE. SIGN BELOW IF YOU AGREE TO THE CONDITIONS OF OUR TERMS.**

**Signature:** \_\_\_\_\_ **Title:** \_\_\_\_\_ **Date:** \_\_\_\_\_

COMPLETE FORM AND RETURN TO:  
SUDCO INTERNATIONAL CORPORATION, 2410 S Sequoia, COMPTON, CA 90220  
TEL: 310-637-8330 FAX: 310-637-8331





# Credit Card Authorization

Dealer Name: \_\_\_\_\_

Dealership Address: \_\_\_\_\_

(all orders will be shipped to this address only) \_\_\_\_\_

\_\_\_\_\_

Phone Number: \_\_\_\_\_

Name on the credit card Account: \_\_\_\_\_

Credit Card Billing Address: \_\_\_\_\_

Visa

Mastercard

American Express

Account Number: \_\_\_\_\_ Exp: \_\_\_\_\_

## Optional Second Credit Card

Visa

Mastercard

American Express

Account Number: \_\_\_\_\_ Exp: \_\_\_\_\_

Card Holder Signature: \_\_\_\_\_

I authorize Sudco International Corp. to charge the above credit card(s) for purchases and shipments to the above motorcycle shop/ dealership.

Complete form and return to:  
Sudco International Corp, 2410 S Sequoia, COMPTON, CA 90220  
Tel: 310-637-8330 FAX: 310-637-8331

# SUDCO

Should you prefer COD, please check here.

## California Resale Certificate

**I HEREBY CERTIFY:**

1. I hold valid seller's permit number: \_\_\_\_\_

2. I am engaged in the business of selling the following type of tangible personal property:

\_\_\_\_\_

3. This certificate is for the purchase from \_\_\_\_\_ of the item(s) I have listed in paragraph 5 below. [Vendor's name]

4. I will resell the item(s) listed in paragraph 5, which I am purchasing under this resale certificate in the form of tangible personal property in the regular course of my business operations, and I will do so prior to making any use of the item(s) other than demonstration and display while holding the item(s) for sale in the regular course of my business. I understand that if I use the item(s) purchased under this certificate in any manner other than as just described, I will owe use tax based on each item's purchase price or as otherwise provided by law.

5. Description of property to be purchased for resale:

6. I have read and understand the following:

**For Your Information:** A person may be guilty of a misdemeanor under Revenue and Taxation Code section 6094.5 if the purchaser knows at the time of purchase that he or she will not resell the purchased item prior to any use (other than retention, demonstration, or display while holding it for resale) and he or she furnishes a resale certificate to avoid payment to the seller of an amount as tax. Additionally, a person misusing a resale certificate for personal gain or to evade the payment of tax is liable, for each purchase, for the tax that would have been due, plus a penalty of 10 percent of the tax or \$500, whichever is more.

NAME OF PURCHASER

SIGNATURE OF PURCHASER, PURCHASER'S EMPLOYEE OR AUTHORIZED REPRESENTATIVE



PRINTED NAME OF PERSON SIGNING

TITLE

ADDRESS OF PURCHASER

TELEPHONE NUMBER

( )

DATE

# California Dealers Only

# Table of Contents

## Index

Complete Index 528-546

## Vintage

Body Parts 73  
Brake Pads & Brake Shoes 56-57  
Cam Chain Products 42-44  
Control 62-67  
Engine Valve Products 36-37  
Exhaust 2-3  
Fuel Tank Products 72  
Gaskets 24-29  
Ignition 74-93  
Intake (Air Filters & Carburetor) 4-23  
Stators 94  
Switches 62, 96-97

## Intake

Carburetor Repair Kits 238-243  
Fuel Petcock Repair Kits & Valves 262-267  
K&N Air Filters 270-277

## Keihin

CR Special Racing Carburetors 122-131  
FCR & FCR-MX Carburetors 100-121  
PE Carburetors 144-145  
PJ Carburetors 140-141  
PWK Carburetors 132-139  
PWM Carburetors 142-143

## Mikuni

HSR Carburetors 170-177  
RS Smoothbore Carburetors 160-165  
TM Flat Slide Carburetors 178-186  
TMX Series Carburetors 187-191  
VM Roundslide Carburetors 192-201  
VM29 Smoothbores 166-167  
VM33 Smoothbores 168-169  
Needle Valve Sets 210-211,  
246-247

Sudco Intake Carb Holders 220-223

## Engine

Cam Chain Products 353-359  
Cam Chains 360-362  
Chain, Drive 408-409  
Clutch Plates, and Springs 391-407  
Connecting Rod Kits 370-371  
Engine Valves 346-350  
Exhaust Systems 336-337  
Gaskets 280-286  
Individual Gaskets 287-308,  
322-335  
Oil Filters 372-390  
Oil Seal Kits 320-321

## Engine

Piston Products 364-369  
Valve Adjustment Shims 340-345  
Valve Stem Seals & Valve Keepers 310-319

## Suspension

Fork Seal & Fork Dust Seal Kits 410-423  
Suspension Accessories 424-425

## Control

Brake Pads & Brake Shoes 448-464  
Master Cylinder Rebuild Kits 434-439  
Motion Pro Control Products 441-445  
Steering Stem Bearings Kits 426-433

## Electrical

Batteries 481  
Ignition Products 470-477  
NGK Products 466-470  
Switches 478-479

## Chemical

Chemical Accessories 492-493  
Mothers Polish 482-483  
PJ1 Products 487-489  
Redline Lubricants 490-491  
Three Bond Sealants 485  
Valco Sealants 486

## Tools

Brake Tools 504  
Carburetor Tools 494-498  
Chain Tools 506  
Flywheel Pullers 509-511  
Shop Tools 499, 502-503  
Suspension Tools 508  
Wheel Tools 507  
Wrenches 500-501

## Watercraft

Engine 524-525  
Fuel Pumps 516  
Keihin 512-514  
Mikuni 515-523

## Dealer Applications

**Note:** For complete INDEX see page 528-546

## *Sudco H1-500 Replica Exhaust Pipe Set*



### **Sudco H1-500 Replica Exhaust Pipe Set**

Replica of the stock H1-500 triple exhaust pipe system. Set includes 3 individual exhaust pipes, mufflers, flanges, and exhaust clamps. (gaskets, and hardware not included) Fits H1-500 triples from 1969 to 1971.

Order No. [502-701](#)



## *Sudco Z1-900 Replica Exhaust Pipe Set*



### **Sudco Z1-900 Replica Exhaust Pipe**

This replica of the Kawasaki Z1-900 exhaust system is an exact copy except for stamped numbering system. Set includes 4 individual exhaust pipes. (mounting hardware and gaskets not included) For mounting hardware see [900-565](#). Fits Z1/A/B-900 from 1973 to 1975.

Order No. [502-700](#)



# Sudco H2-750 Replica Exhaust Pipe Set



## Sudco H2-750 Replica Exhaust Pipe Set

Replica of the stock H2-750 triple exhaust pipe system. Set includes 3 individual exhaust pipes, mufflers, flanges, and exhaust clamps. (gaskets, and hardware not included) Fits H2/A-750 triples from 1972 to 1973.

Order No. [502-702](#)

# Sudco Z1-900 Replica Muffler Mounting Kit & Exhaust Pipe Gasket



## Sudco Z1 Muffler Mounting Kit

Kit includes mounting hardware, clamps, rubber bushings (as shown) and exhaust pipe gaskets (not shown) needed to install Sudco Z1 replica exhaust pipe or OEM exhaust pipe.

Order No. [900-565](#)

## Exhaust Pipe Gaskets

Exhaust pipe gaskets are sold each. Available for H1-500, H2-750, and Z1-900 models listed. For other models, see page [290-299](#) in Engine section. *Made in Japan.*

Model	Year	Order No.
H1/H1A/H1B/H1C/H1D/H1E-500	69-75	<a href="#">503-403</a>
KH500A8	1976	<a href="#">503-403</a>
H1/H2A/H2B/H2C-750	72-75	<a href="#">503-403</a>
Z1/Z1A/Z1B-900	73-75	<a href="#">503-405</a>

# Sudeo KEIHIN Street Carb Kits



## Moto-Guzzi 1100 Kit

Kit includes pre-jetted Keihin FCR41 carb, velocity stacks, throttle and throttle cables. **Note: Does not utilize stock airbox.**

Model	Year	Description	Order No.
1100 Sport Carb Kit	94-96	Keihin FCR41 Kit	<b>016-744</b>

## Norton Commando Kit

Kit includes pre-jetted Keihin FCR35 carbs, 2 K&N Filters, throttle and throttle cables. **Requires Amal MKII Conversion Manifolds.**

Model	Year	Description	Order No.
Commando 750/850		Keihin FCR35 Kit	<b>016-860</b>

# Sudeo MIKUNI Street Carb Kits



## Harley-Davidson® Kits

Kits include pre-jetted Mikuni VM carburetor, throttle cable, K&N Air Filter, Sudco/Mikuni Tuning Manual, manifolds, additional jets for fine tuning and all necessary adapters.

Model	Description	Order No.
Sportster**/Shovelhead	Mikuni VM38 HDS-101/38mm	<b>001-200</b>
Sportster**/Shovelhead	Mikuni VM44 HDS-101B/44mm	<b>001-202</b>
Knucklehead/Panhead	Mikuni VM38 HDS-102/38mm	<b>001-201</b>
Knucklehead/Panhead	Mikuni VM44 HDS-102B/44mm	<b>001-205</b>

\*\*Sportster 1984 and earlier models only

## Honda CB/CL350 Kit

Kits include pre-jetted Mikuni VM Round Slide carburetors, K&N RC-1250 Air Filters and 2 into 1 throttle cable.

Description	Year	Order No.
Mikuni VM30 Kit	1968-1973	<b>001-247</b>

## Kawasaki H2-750 Kits

Kits include pre-jetted Mikuni TM Flat Slide carburetors, K&N RC-1250 Air Filters and rubber mounting flanges.

Description	Year	Order No.
Mikuni TM32 Kit	1972-1975	<b>001-239</b>
Mikuni TM34 Kit	1972-1975	<b>001-241</b>





## Norton Commando 750/850 Kits

Kits include Mikuni VM pre-jetted carb, rubber flanges, manifolds, spare jets and Sudco/Mikuni Tuning Manual.

**Cables not included with kits. Order separately.**

**Note:** VM Roundslide carburetors may be upgraded to TM Flat Slide carburetors on many applications. Ask your Sudco sales rep. for details.

Description	Order No.
Mikuni VM32 Dual Kit	001-250
Mikuni VM34 Dual Kit	001-251
Mikuni VM34 Single Kit	001-252
Mikuni VM36 Single Kit	001-253
Mikuni VM38 Single Kit	001-254
Throttle Cable for VM34 Single Carb Kit	007-575
Throttle Cable for VM36, VM38 Single Carb Kit	007-576
Throttle Cable for VM32, VM34 Dual Carb Kits	002-025

## Norton Atlas Kit

Kit includes Mikuni VM pre-jetted carb, rubber flange, manifold, spare jets and Sudco/Mikuni Tuning Manual.

Description	Order No.
VM34 Single Kit	001-233

**Air Filter will not fit. Cables not included with kit. Order separately.**



## Royal Enfield 500 Kits

Kits include Mikuni VM pre-jetted carb, rubber flange, manifold spacer plate, mounting bolts, throttle cable, K&N RU-0600 Air Filter, fuel lines and a Sudco/Mikuni Tuning Manual.

Description	Year	Order No.
Mikuni VM30 Kit	00 on	001-265
Mikuni VM32 Kit	00 on	001-266
Mikuni VM34 Kit	00 on	001-237

## Yamaha XS650 Kit

Kit includes pre-jetted Mikuni VM34 carbs, rubber mounting flanges, spare jets, K&N RB-0610 Air Filter, throttle cable and Sudco/Mikuni Tuning Manual.

**Note: Removal or slight modifying of side covers required.**

Model	Year	Description	Order No.
XS650	70-79	VM34 Kit	001-235
Replacement Throttle Cable only for VM34 Kit			021-960



## Triumph Bonneville VM Kits

Kits include Mikuni VM pre-jetted carbs, rubber flanges when applicable, manifolds, air filters, spare jets and Sudco/Mikuni Tuning Manual.

Description	Year	Order No.
Mikuni VM30 Kit	1964-mid 1968	001-278
Mikuni VM32 Kit	1964-mid 1968	001-279
Mikuni VM34 Kit	1964-mid 1968	001-280
Mikuni VM30 Kit	1969-mid 1972	001-275
Mikuni VM32 Kit	1969-mid 1972	001-276
Mikuni VM34 Kit	1969-mid 1972	001-277
Mikuni VM30 Kit	1973-1978	001-290
Mikuni VM32 Kit	1973-1978	001-291
Mikuni VM34 Kit	1973-1978	001-292
Throttle Cable only for VM30 -34 Kits		007-578

**Throttle Cable part number 007-578 requires 2 for junction box.**



## Triumph TR6/TR7 Single Kits

Kits include Mikuni VM pre-jetted carb, rubber flange, manifold, spare jets Sudco/Mikuni Tuning Manual and air filters.

Description	Year	Order No.
Mikuni VM30 Kit	1947-1981	001-293
Mikuni VM32 Kit	1947-1981	001-294
Mikuni VM34 Kit	1947-1981	001-295

Replacement Throttle Cable only for VM Kits **007-577**



# Sudco Intake Carb Holders



005-898



005-865

## Sudco Intake Carb Holders for Vintage

Use with the original OEM carburetors. **Made in Japan** to OEM specifications. Sold in kits. Order per Sudco part number. **Stock OEM hose clamps must be used when installed.** Note: Some of the applications listed require o-ring or gasket. LH to RH - From left to right behind engine when installing.

### Honda

#### Carb Holder Kit CB750KO Order No. 005-897

Includes qt 4 Carb Holders  
LH & RH outside only, 16211-300-305 (1 & 4)  
LH & RH inside only, 16212-300-305 (2 & 3)

#### Application

CB750KO 69-70

#### Carb Holder Kit CB750K1-K5 Order No. 005-898

Includes qt 4 Carb Holders  
LH & RH outside only, 16211-300-030 (1 & 4)  
LH & RH inside only, 16212-300-030 (2 & 3)

#### Application

CB750K1-K5 71-75  
CB750K 1976  
CB750F Super Sport 1976

### Kawasaki

#### Carb Holder Kit Z1/KZ900/KZ1000 Order No. 005-865

Includes qt 2 LH Carb Holders and qt 2 RH Carb Holders  
LH side only, 16065-029  
RH side only, 16065-028

Z1/Z1A/Z1B 900 73-75  
KZ900A4 1976  
KZ900B1 LTD 1976  
KZ1000A1/A2 77-78  
KZ1000A3/A4 MKII 79-80  
KZ1000B1/B2/B3/B4 LTD 77-80  
KZ1000C1-C4 Police 78-81  
KZ1000E1/E2 Shaft 79-80  
KZ1000D1 Z1R 1978  
KZ1000D3 Z1R 1980

#### Carb Holder Kit KZ1000/KZ1100 Order No. 005-866

Includes qt 4 Carb Holders  
LH & RH sides 16065-1135  
KZ1000J1/J2 81-82  
KZ1000K1/K2 LTD 81-82  
KZ1000M1/M2 CSR 81-82  
KZ1000P1-P21 Police 82-02  
KZ1000P24 Police 2005  
KZ1000R1 Replica 1982  
KZ1100A1/A2 Shaft 81-82  
KZ1100B2 GPz 1982  
KZ1100D1 Spectre 1982

### Kawasaki

#### Carb Holder Kit KZ1000/1100/ZX1100 Order No. 005-867

Includes qt 4 Carb Holders  
LH & RH sides, 16065-1131  
KZ1000J3 1983  
KZ1000R2 Replica 1983  
KZ1100A3 Shaft 1983  
KZ1100D2 Spectre 1983  
KZ1100L1 LTD 1983  
ZN1100B1/B2 LTD 84-85  
ZX1100A1/A2 GPz 83-84

### Yamaha

#### Carb Holder Kit XT600 Order No. 005-885

Includes qt 1 LH Carb Holder,  
qt 1 RH Carb Holder and qt 2 Intake O-Rings  
LH Carb Holder, 43F-13586-01-00  
RH Carb Holder, 43F-13596-01-00  
Intake O-Ring, 93210-36549  
XT600EA/EAC/EB/EBC/ED/EDC 90-92  
XT600EE/EEC/EF/EFC/EG/EGC 93-95

#### Carb Holder Kit XS650 Order No. 005-877

Includes qt 1 LH Carb Holder and qt 1RH Carb  
Holder  
LH Carb Holder, 3G1-13586-00-00  
RH Carb Holder, 447-13596-00-00  
XS650G/H Special II 80-81  
XS650SG/SH Special 80-81  
XS650SJ/SK Heritage Special 82-83

#### Carb Holder Kit XS750/850 Order No. 005-888

Includes qt 3 Carb Holders 2F3-13586-01-00  
XS750E/F 78-79  
XS750SE/SF Special 78-79  
XS850G/H 80-81  
XS850LG/LH Midnight Special 80-81  
XS850SG/SH Special 80-81



005-885



005-880

## Yamaha

### Carb Holder Kit SR500/TT500/XT500 Order No. 005-880

Includes qt 1 Carb Holder and qt 1 Intake Gasket

Carb Holder, 583-13565-01-00

Intake Gasket, 583-13556-01-00

SR500E/F/G/H 78-81

TT500C/D/E/F/G/H 76-81

XT500C/D/E/F/G/H 76-81

### Carb Holder Kit FZ600 Order No. 005-881

Includes qt 2 LH Carb Holders, qt 2 RH Carb Holders and qt 4 Intake Gaskets

LH side, 1 & 2, 33M-13586-01-00

RH side, 3 & 4 33M-13596-01-00

Intake Gasket, 33M-13556-00-00

FZ600S/SC/T/TC/U/UC 86-88

### Carb Holder Kit YX600 Order No. 005-882

Includes qt 2 LH Carb Holders, qt 2 RH Carb Holders and qt 4 Intake Gaskets

LH side 1 & 2, 33M-13586-01-00

RH side, 3 & 4 33M-13596-01-00

Intake Gasket, 3KM-13556-00-00

YX600S/SC/T/TC/U/UC/W/WC/A/AC Radian 86-90

### Carb Holder Kit XS1100 Order No. 005-879

Includes qt 2 LH Carb Holders and qt 2 RH Carb Holders

LH side, 1 & 2, 2H7-13586-00-00

RH side, 3 & 4 2H7-13596-00-00

XS1100E/F/G/H 78-81

XS1100LG/LH Midnight Special 80-81

XS1100SF/SG/SH Special 79-81

### Carb Holder Kit TT/XT600 Order No. 005-884

Includes qt 1 LH Carb Holder, qt 1 RH Carb Holder, and qt 2 Intake O-Rings

LH side, 43F-13586-01-00

RH side, 43F-13596-01-00

Intake O-Ring, 93210-36549

TT600N 1985

XT600L/LC/N/NC/S/SC/T/TC/U/UC/W/WC 84-89

### Carb Holder Kit XS650 Order No. 005-878

Includes qt 1 LH Carb Holder and qt 1 RH Carb Holder

LH Carb Holder, 447-13555-01-00

RH Carb Holder, 447-13565-01-00

TX650A 1974

XS650B/C/D 75-77



005-950



005-955

## Carb Holder Clamp

Fits stock carb holder. Dark green color.

Made in Japan. Sold each, and set/ 4.

## Kawasaki

Carb Holder Clamp, each Order No. 005-950 (45.56mm I.D.)

Carb Holder Clamp, set/4 Order No. 005-950S

Z1/A/B-900 73-75

KZ900A4/A5 76-77

KZ1000A1/A2 77-78

KZ1000A3/A3A/A4 MKII 79-80

KZ1000B1/B2/B3/B4 LTD 77-78

KZ1000D1 Z1R 1978

KZ1000D3 Z1R 1980

KZ1000E1/E2 Shaft ST 79-80

Carb Holder Clamp, each Order No. 005-955 (52mm I.D.)

Carb Holder Clamp, set/4 Order No. 005-955S

KZ1000J1/J2/J3 81-83

KZ1000K1/K2 LTD 81-82

KZ1000M1/M2 CSR 81-82

KZ1000P1-P21 Police 82-02

KZ1000P24 Police 2005

KZ1100A1/A2/A3 Shaft 81-83

KZ1100D1/D2 Spectre 82-83

KZ1100L1 Shaft LTD 1983

ZN1100B1/B2 Shaft LTD 84-85

ZX1100A1/A2 GPz 83-84



## Sudco Carb Vacuum Fitting Cap

Replacement part for Mikuni RS Smoothbore carburetors.

This rubber plug is found on many Yamaha models.

Made in Japan. Sold each.

Order No. 002-646



## K&L Supply Carb Holder Rubber Plugs

Universal rubber plug has many uses. Made in Japan. Sold pk/5.

Order No. 005-860

# Replacement Air Filters



## OEM Type Replacement Air Filters

Paper element air filter. Fits stock airbox. Sold each.

### Honda

Model	Year	OEM Reference	Order No.
CB750K0/K1-K5	69-75	17211-405-000	<b>005-353T</b>
CB750K	76-78	17211-405-000	<b>005-353T</b>
CB750F Super Sport	75-78	17211-405-000	<b>005-353T</b>

### Kawasaki

Z1/A/B-900	73-75	11013-034	<b>005-350T</b>
KZ1000A1/A2/	77-78	11013-063	<b>005-351T</b>
KZ1000A3/A3A/A4 MKII	79-80	11013-063	<b>005-351T</b>
KZ1000B1-B4 LTD	77-80	11013-063	<b>005-351T</b>
KZ1000C1-C4 Police	78-81	11013-063	<b>005-351T</b>
KZ1000D1 Z1R	1978	11013-063	<b>005-351T</b>
KZ1000D1 Z1R	1980	11013-063	<b>005-351T</b>
KZ1000J1/J2/J3	81-83	11013-1037	<b>005-352T</b>
KZ1000K1/K2 LTD	81-82	11013-1037	<b>005-352T</b>
KZ1000M1/M2 CSR	81-82	11013-1037	<b>005-352T</b>
KZ1000P1-P21 Police	82-02	11013-1037	<b>005-352T</b>
KZ1000R1/R2 Replica	82-83	11013-1037	<b>005-352T</b>
KZ1100A1/A2/A3 Shaft	81-83	11013-1037	<b>005-352T</b>
KZ1100D1/D2 Spectre	82-83	11013-1037	<b>005-352T</b>
KZ1100L1 LTD Shaft	1983	11013-1037	<b>005-352T</b>



## K&N OE Replacement Air Filters

K&N replacement air filters are designed to fit right into your stock airbox. **Made in the USA.** Sold each.

### Honda

Model	Year	K&N No.	Order No
CB700SC Nighthawk	84-86	HA-7084	<b>005-372</b>
CB750A Automatic	76-78	HA-0100	<b>005-357</b>
CB750C Custom	80-82	HA-1079	_____
CB750F Super Sport	75-78	HA-0100	<b>005-357</b>
CB750K0/K1-K5	69-75	HA-0100	<b>005-357</b>
CB750K	76-78	HA-0100	<b>005-357</b>
GL1500 Goldwing	88-90	HA-8088	<b>005-709</b>

### Kawasaki

H1/A/B/C/D/E/F-500	69-75	KA-1000	<b>005-351</b>
KZ550H1/H2 GPz	82-83	KA-1700	_____
H2/A/B/H2C-750 Mach IV	72-75	KA-1100	<b>005-554</b>
Z1/A/B-900	73-75	KA-0800	<b>005-350</b>
KZ1000J1/J2/J3	81-83	KA-1600	<b>005-557</b>
KZ1000K1/K2 LTD	81-82	KA-1600	<b>005-557</b>
KZ1000M1/M2 CSR	81-82	KA-1600	<b>005-557</b>
KZ1000P1-P21 Police	82-02	KA-1600	<b>005-557</b>
KZ1000R1/R2 Replica	82-83	KA-1600	<b>005-557</b>
KZ1100A1/A2/A3 Shaft	81-83	KA-1600	<b>005-557</b>
KZ1100D1/D2 Spectre	82-83	KA-1600	<b>005-557</b>
KZ1100L1 LTD	1983	KA-1600	<b>005-557</b>

### Yamaha

XS650C/D/E/F/2F	76-79	YA-1152	_____
XS650SE/SF	78-79	YA-1152	_____
XV700L/LC/N/NC Virago	84-85	YA-1186	<b>005-739</b>
XV700CS/CSC/CT/CTC Virago	86-87	YA-1186	<b>005-739</b>
XV700SS/SSC Virago	1986	YA-1186	<b>005-739</b>
XV750 Virago	88-97	YA-1186	<b>005-739</b>
XV1000L/LC/N/NC Virago	84-85	YA-1186	<b>005-739</b>
XV1100 Virago	86-99	YA-1186	<b>005-739</b>
VMX12 V-Max	85-86	YA-1285	<b>005-582</b>



## K&N Recharger® Filter Care Service Kit

This six step maintenance system is designed to recharge any K&N Filtercharger® Air Filter. It restores air flow efficiency so your Filtercharger® performs like new.

<b>Recharger® Filter Care Service Kit</b>	<b>K&amp;N No.</b>	<b>Order No.</b>
Kit includes 6-1/2 oz. aerosol spray oil,	99-5000	<b>005-540</b>
12 oz. filter cleaner and service decal.		

### Recharger® Filter Care Service Kit

Kit includes 8 oz. squeeze oil, 12 oz. filter cleaner and service decal. Same as **005-540** except has squeeze bottle instead of spray can.



## K&N Filtercharger® Oil

The only oil specially formulated to work with in combination with the cotton fabric in K&N Filtercharger® elements providing outstanding air filtration. When used as directed, it quickly penetrates the filter pleats, where it remains suspended in the cotton fabric unit until the element is cleaned with K&N Air Filter Cleaner.

<b>Air Filter Oil</b>	<b>K&amp;N No.</b>	<b>Order No.</b>
6-1/2 oz. aerosol can	99-0504	<b>005-530</b>
12 oz. aerosol can	99-0516	<b>005-532</b>
8 oz. squeeze bottle	99-0533	<b>005-534</b>

### Air Filter Cleaner & Degreaser

32 fl. oz. squirt bottle	99-0621	<b>005-520</b>
--------------------------	---------	----------------

The only cleaner formulated for K&N Filtercharger® elements. **Note:** Not to be used on polished anodized aluminum.



## Kawasaki Z1-900 73-75 Replica Air Box

The OEM style replica rubber and plastic airbox assembly fits Kawasaki Z1-900 1973-75 models.

Order No. **950-251**



## Kawasaki H2-750 Air Box Complete

Made of thin fiberglass. Satin black finish.

Order No. **950-250**



900-183



900-184

## Kawasaki H2-750 Replica Inlet Tube & Top Duct

OEM style replica rubber fits Kawasaki H2-750 1972-73 model.

<b>Description</b>	<b>Order No.</b>
Air Inlet Tube	<b>900-183</b>
Top Duct	<b>900-184</b>

# Carburetor Repair Kits, & Carb Top Gasket

VINTAGE  
INTAKE  
ENGINE  
SUSPENSION  
CONTROL  
ELECTRICAL  
CHEMICAL  
TOOLS  
WATERCRAFT



025-610



025-426

## Vintage Street Carburetor Repair Kits

Each kit contains necessary parts to rebuild one OEM carburetor body.  
**Made in Japan. Note- Check all parts before installation.**

### Honda

Model	Carburetor	Year	Order No.
CB72 Hawk 250		61-66	025-610
CL72 Scrambler 250		62-65	025-611
CB77 Super Hawk 305		61-68	025-610
CL77 Scrambler 305	20mm	65-68	025-611
CB350F Super Sport		72-74	025-609
CB400F Super Sport		75-77	025-612
CB750K0	28mm	69-70	025-613



025-600

### Kawasaki

S1A/S1B/S1C-250	VM22SC	73-75	025-680
KH250A5	VM22SC	1976	025-680
S2/S2A-350	VM24SC	72-73	025-681
S3/S3A-400	VM26SC	74-75	025-682
KH400A	VM26SC	76-78	025-682
H1/A/C-500 Mach III	VM28SC	69-72	025-603
H1B/D/E/F-500	VM28SC	73-75	025-601
H2/A-750 Mach IV	VM30SS	72-73	025-602
Z1/A/B-900	VM28SS	73-75	025-600
KZ1000A1/A2	VM26SS	77-78	025-604
KZ1000A3/A3A MKII	VM28SS	1979	025-605
KZ1000A4 MKII	VM28SS	1980	025-606
KZ1000B1/B2 LTD	VM26SS	77-78	025-604
KZ1000B3 LTD	VM26SS	1979	025-605
KZ1000B4 LTD	VM28SS	1980	025-606
KZ1000C1/C1A Police	VM26SS	1978	025-604
KZ1000C2 Police	VM26SS	1979	025-606
KZ1000C3/C4 Police	VM28SS	80-81	025-606
KZ1000D1 Z1R	VM28SS	1978	025-604
KZ1000D3 Z1R	VM28SS	1980	025-606
KZ1000E1/E2 Shaft ST	VM28SS	79-80	025-605
KZ1000J1/J2	BS34	81-82	025-614
KZ1000K1/K2 LTD	BS34	81-82	025-614
KZ1000M1/M2 CSR	BS34	81-82	025-614
KZ1000P1-P21 Police	BS34	82-02	025-614
KZ1000R1/R2 Replica	BS34	82-83	025-614

### Suzuki

Model	Carburetor	Year	Order No.
GT380L/M/A/B Sebring	VM24SC	74-77	025-425
GT750L/M/A/B Lemans	BS	74-77	025-426

### Yamaha

RD350/A/B	VM28SC	73-75	025-623
RD400C/D/E	VM28SC	76-78	025-624



## Sudco Carburetor Top Cap Cover Gasket

GENUINE replacement top cap cover gasket. Fits Kawasaki and Suzuki 4-cylinder models with stock Mikuni VM carburetors.  
Sold each. Order No. 002-524

### Kawasaki

Model	Year
KZ650B1/B2/B2A/B3	77-79
KZ650C1/C2/C3 Custom	77-79
KZ650D1/D1A/D2 SR	78-79
KZ650E1	1980
KZ650F1	1980
KZ650H1 CSR	1981
KZ900A4/A5	76-77
KZ900B1 LTD	1976
KZ1000A1/A2	77-78
KZ1000B1/B2/B3/B4 LTD	77-80
KZ1000C1/C1A/C2/C3/C4 Police	78-81
KZ1000D1 Z1R	1978
KZ1000D3 Z1R	1980
KZ1000E1/E2 Shaft ST	79-80

### Suzuki

GS550B/C/EC/N/EN	77-79
GS550LN	1979
GS750B/C/EC/N/EN	77-79
GS750LN	1979
GS850GN	1979
GS1000C/EC/N/EN	78-79
GS1000LN	1979





## Sudco Mikuni Needle Valve Assemblies

Genuine OEM "MIKUNI" replacement needle valve assemblies. **Made in Japan.** Order by Sudco part number. **See page 12-14 for applications.**

### Kawasaki

Model & Year	Size	OEM Reference	Order No.
H1-500/H2-750 (all)	2.5	16030-005	<a href="#">007-955</a>
KZ750 2-cyl. (76-80)	2.0	16030-026	<a href="#">007-976</a>
KZ900/1000 (76-80)	2.3	16030-027	<a href="#">007-966</a>
KZ650 (77-80)	2.0	16030-1001	<a href="#">007-958</a>
KZ1000/1100 (81-85)	2.5	16030-1016	<a href="#">007-956</a>

### Suzuki

LS650 Savage (all)	2.5	13370-24C80	<a href="#">007-970</a>
GN250 (82-88)	2.5	13370-37400	<a href="#">007-970</a>
GS750E (80-82)	2.0	13370-44500	<a href="#">007-957</a>
GS850G (80-83)	2.0	13370-44500	<a href="#">007-957</a>
GS550 (77-79)	2.3	13370-45010	<a href="#">007-966</a>
GS1000 (77-78)	2.3	13370-45010	<a href="#">007-966</a>
GT750 Lemans (74-77)	2.0	13372-31210	<a href="#">007-976</a>

### Yamaha

XS750/XS1100 (77-79)	2.0	1J7-14190-20-00	<a href="#">007-976</a>
XS400/RJ Maxim/Seca	2.0	11H-14107-20-00	<a href="#">007-957</a>
XS650 (72-79)	2.0	168-14190-20-00	<a href="#">007-958</a>
XS1B-650 (1971)	2.5	168-14190-25-00	<a href="#">007-955</a>
RD250, RD350, RD400	2.5	23L-14107-25-00	<a href="#">007-955</a>
FJ600 (84-85)	2.0	25G-14107-20-00	<a href="#">007-503</a>
FJ1200 (86-87)	2.3	25G-14107-23-00	<a href="#">007-504</a>
FJ1200 (89-93)	1.5	3CF-14107-15-00	<a href="#">007-980</a>



## GENUINE Mikuni Needle Valve Seat Filter

Fits OEM push type needle valve assembly. **Made in Japan.** Sold each. Needle Valve Assembly not included.

Order No. [002-606](#)

**Kawasaki** OEM 14043-1010 - late model KZ1000/1100  
**Suzuki** 13376-19F00 - GS series - GS750/1000/1100  
**Yamaha** 1J7-14994-00-00 - XS1100 Series

## Sudco Keihin Needle Valves

Genuine OEM KEIHIN Needle Valves, with clip. Available for Keihin Aftermarket (genuine) and Keihin OEM (genuine) carburetors. **Made in Japan.** Sold each. **See page 12-14 for applications.**

### Honda

OEM Reference	Model/Application	Order No.
16011-382-004	CB750K/CB750F (76-78)	<a href="#">018-880</a>
16155-413-751	CB750C/K (80-82)	<a href="#">021-862</a>

### Kawasaki

16030-1007	KZ400/KZ440//ZX900A	<a href="#">018-880</a>
16030-1057	VN700/VN750 Vulcan	<a href="#">018-884</a>

### Yamaha

371-14990-60-00	TX500/XS500B	<a href="#">018-880</a>
-----------------	--------------	-------------------------

**Note: Needle only, does not include needle valve seat.**

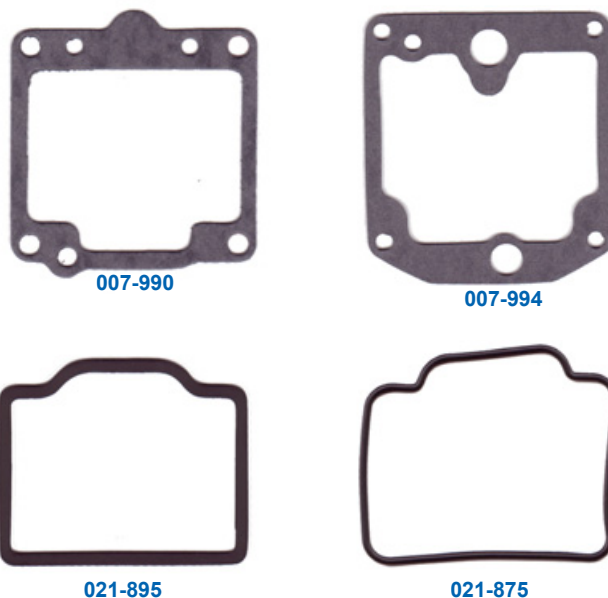

## Sudco Float Bowl Gaskets & O-Rings

OEM (genuine) replacements. Sold each. **Made in Japan.** **Model applications begin on page 12.** **OEM Reference is listed on page 250.**

# Needle Valve Sets, Needle Valves, Gaskets, & O-Rings

## Honda Street

Model	Year	Needle Valve Assy	Needle Valve	Float Bowl Gasket/O-Ring
C70 Passport	80-83	—	—	021-884
CT70H/HK1 Trail 70H	70-73	—	—	021-896
CT70K1/K2/K3/K4 Trail 70	72-75	—	—	021-896
CT70 Trail 70	76-77	—	—	021-896
CT70 Trail 70	80-82	—	—	021-884
CT90K1/K2/K3/K4 Trail 90	69-73	—	—	021-896
CT90K5/K6 Trail 90	74-75	—	—	021-896
CT90 Trail 90	76-77	—	—	021-896
CT90 Trail 90	78-79	—	—	021-884
ST90/K1/K2 Trailsport 90	73-75	—	—	021-896
XL100	77-78	—	018-880	021-886
XL100S	79-85	—	018-880	021-886
CB125S	78-82	—	018-880	—
MT125R	1978	—	018-883	018-113
NX125	88-90	—	—	021-886
XL125 Carb ID PD65A	1976	—	018-880	021-886
XL125	77-78	—	018-880	021-886
XL125S	79-82	—	018-880	021-886
XL125S	84-85	—	018-880	021-886
CM185T Twinstar	78-79	—	018-880	021-886
XL185S	79-82	—	018-880	021-886
XL185S	1983	—	—	021-886
CM200T Twinstar	80-82	—	018-880	021-886
XL200R	83-84	—	—	021-886
CB72 Hawk 250	61-66	—	—	021-895
CL72 Scrambler 250	62-65	—	—	021-895
CM250C	82-83	—	—	021-883
XL250K/K1/K2 Motosport	72-75	—	—	021-889
XL250	1976	—	—	021-889
XL250S	78-81	—	018-880	021-886
XL250R	1982	—	—	021-886
XL250R	84-87	—	018-880	021-886
CB77 Super Hawk 305	61-68	—	—	021-895
CL77 Scrambler 305	65-68	—	—	021-895
XL350	76-78	—	018-880	—
XL350R	84-85	—	018-880	—
CB400A Automatic	1978	—	018-880	021-883
CB400T1 Hawk	78-79	—	018-880	021-883
CB400T11 Hawk	78-79	—	018-880	021-883
CB400T Hawk	80-81	—	021-862	021-883
CM400A Automatic	1979	—	018-880	021-883
CM400A Automatic	80-81	—	021-862	021-883
CM400C Custom	1981	—	021-862	021-883
CM400E	80-81	—	021-862	021-883
CM400T	1979	—	018-880	021-883
CM400T	80-81	—	021-862	021-883
CB450SC Nighthawk	82-83	—	021-862	021-883
CB450SC Nighthawk	1985	—	021-862	021-883
CB450SC Nighthawk	1986	—	021-862	021-883
CB450T Hawk	1982	—	021-862	021-883
CM450A Automatic	82-83	—	021-862	021-883
CM450C Custom	1982	—	021-862	021-883
CM450E	82-83	—	021-862	021-883
CX500	78-79	—	018-880	021-883
CX500C Custom	1979	—	018-880	021-883
CX500C Custom	80-82	—	021-862	021-883
CX500D Deluxe	1979	—	018-880	021-883
CX500D Deluxe	80-82	—	—	021-883
FT500 Ascot	82-83	—	—	021-883
GL500 Silverwing	81-82	—	—	021-883
GL500I Silverwing Interstate	81-82	—	—	021-883

## Honda Street

Model	Year	Needle Valve Assy	Needle Valve	Float Bowl Gasket/O-Ring
VF500C Magna	84-85	—	018-880	—
VF500F Interceptor	84-85	—	018-880	—
XL500S	79-81	—	018-880	021-886
XL500R	1982	—	—	021-886
CB550K	77-78	—	018-880	—
CB550SC Nighthawk	1983	—	—	021-880
VT600C Shadow	88-89	—	018-880	021-885
XL600R	83-87	—	018-880	—
CB650	79-80	—	018-880	—
CB650	81-82	—	—	021-883
CB650C Custom	1980	—	018-880	—
CB650C Custom	81-82	—	—	021-883
CB650SC Nighthawk	1982	—	—	021-883
CB650SC Nighthawk	83-85	—	—	021-880
CX650C Custom	1983	—	—	021-883
GL650 Silverwing	1983	—	—	021-883
GL650I Silverwing Interstate	1983	—	—	021-883
NT650 Hawk GT	88-91	—	018-880	021-885
CB700SC Nighthawk	84-85	—	—	021-880
CB700SC Nighthawk	1986	—	018-880	021-880
VF700C Magna	84-86	—	018-880	021-885
VF700C Magna	1987	—	—	021-885
VF700F Interceptor	84-85	—	018-880	021-885
VF700S Sabre	84-85	—	018-880	021-885
VT700C Shadow	84-85	—	018-880	021-885
VT700C Shadow	86-87	—	018-880	021-885
CB750A Automatic	76-78	—	018-880	021-886
CB750C Custom	80-82	—	021-862	021-883
CB750F Super Sport	76-78	—	018-880	—
CB750F Super Sport	1979	—	018-880	021-883
CB750F Super Sport	80-82	—	—	021-883
CB750K0/K1/K2/K3/K4/K5	69-75	—	—	021-895
CB750K	1976	—	—	021-895
CB750K	77-78	—	018-880	021-886
CB750K	1979	—	018-880	021-883
CB750K	80-82	—	021-862	021-883
CB750L LTD	1979	—	018-880	021-883
CB750SC Nighthawk	82-83	—	021-862	021-883
VF750C V45 Magna	82-83	—	018-880	021-885
VF750F V45 Interceptor	83-84	—	018-880	021-885
VF750S V45 Sabre	82-83	—	018-880	021-885
VT750C Shadow	1983	—	018-880	021-885
VT800C Shadow	1988	—	018-880	021-885
CB900C Custom	80-82	—	—	021-883
CB900F Super Sport	81-82	—	—	021-883
CB1000C Custom	1983	—	021-862	021-883
VF1000F Interceptor	1984	—	018-880	021-885
VF1000R	85-86	—	018-880	021-885
CBX (1047cc)	79-82	—	018-880	021-883
CB1100F Super Sport	1983	—	018-880	021-883
GL1100 Goldwing	80-83	—	018-880	021-883
GL1100A Goldwing Aspencade	82-83	—	018-880	021-883
GL1100I Goldwing Interstate	80-83	—	018-880	021-883
VF1100C V65 Magna	83-86	—	018-880	021-885
VF1100S V65 Sabre	84-85	—	018-880	021-885
VT1100C Shadow	85-86	—	018-880	021-885
VT1100C Shadow	87-89	—	018-880	021-885
GL1200 Goldwing	1984	—	018-880	021-885

# Needle Valve Sets, Needle Valves, Gaskets, & O-Rings

VINTAGE  
INTAKE  
ENGINE  
SUSPENSION  
CONTROL  
ELECTRICAL  
CHEMICAL  
TOOLS  
WATERCRAFT

## Kawasaki Street

Model	Year	Needle Valve Assy	Needle Valve	Float Bowl Gasket/O-Ring
KZ200A1/A2	78-79	—	—	021-895
EL250B2/B3 Eliminator	88-89	—	018-880	021-887
EX250E1/E2 Ninja 250R	86-87	—	018-880	021-887
EX250F2/F3/F4 Ninja 250R	88-90	—	018-880	021-887
KL250A1/A1A/A2 Dual Sport	78-79	—	018-880	021-889
KL250A3/A4/A5 Dual Sport	80-82	—	—	007-991
KL250D2-D22 KLR250 Dual Sport	85-05	—	018-880	021-887
KZ250D1/D2 LTD & CSR	80-81	—	018-880	021-889
KZ250L1 CSR	1982	—	018-880	021-889
KZ250W1 LTD	1983	—	018-880	021-889
EX305B1 GPz	1983	—	018-880	021-889
KZ305A1/A2 CSR	81-82	—	018-880	021-889
KZ305B1 CSR Belt	1981	—	018-880	021-889
KZ305B2/B3 LTD	87-88	—	018-880	021-889
A7-350 Avenger	67-71	—	—	002-009
A7SS-350 Avenger SS	70-71	—	—	002-009
S2/S2A-350	72-73	007-955	—	007-987
S3/S3A-400 (2-stroke triple)	74-75	007-955	—	007-987
KH400A3/A4/A5 (2-stroke triple)	76-78	007-955	—	007-987
KZ400A1/A2 Deluxe	77-78	—	018-880	021-889
KZ400B1/B2	78-79	—	018-880	021-889
KZ400C1	1978	—	018-880	021-889
KZ400/D/D3/D4	74-77	—	018-880	021-889
KZ400H1 LTD	1979	—	018-880	021-889
KZ400S/S2/S3 Special	75-77	—	018-880	021-889
KZ440A1/A2/A3/A4 LTD	80-83	—	018-880	021-889
KZ440B1/B2	80-81	—	018-880	021-889
KZ440D1/D2/D3/D4/D5 LTD	80-83	—	018-880	021-889
KZ440G1 Belt	1982	—	018-880	021-889
EN450A1-A6 LTD 454	85-90	—	018-880	021-887
EX500A1-A7	87-93	—	018-880	021-887
H1/AVB/C-500 (2-stroke triple)	69-72	007-955	—	002-009
H1D/H1E/H1F-500	73-75	007-955	—	002-009
KH500A8 (2-stroke triple)	1976	007-955	—	002-009
KL600A1 KLR600	1984	—	018-884	021-887
KL600B1/B2 KLR600	85-86	—	018-884	021-887
ZL600A1/A2 Eliminator	86-87	—	018-880	021-887
ZX600A1/A2/A3 Ninja 600R	85-87	—	018-880	021-887
ZX600B1 Ninja 600RX	1987	—	018-880	021-887
ZX600C1-C10 Ninja 600R	88-97	—	018-880	021-887
KL650A1-A19 KLR650	87-05	—	018-884	021-887
KZ650B1/B2/B2A	77-78	007-958	—	007-994
KZ650B3	1979	007-958	—	007-997
KZ650C1/C2 Custom	77-78	007-958	—	007-994
KZ650C3 Custom	1979	007-958	—	007-997
KZ650D1/D1A SR	1978	007-958	—	007-994
KZ650D2 SR	1979	007-958	—	007-997
KZ650E1 LTD	1980	007-958	—	007-997
KZ650F1	1980	007-958	—	007-997
KZ650H1 CSR	1981	007-958	—	007-994
KZ650H2/H3 CSR	82-83	—	—	007-990
KZ700A1	1984	007-956	—	007-990
ZN700A1/A2 LTD	84-85	—	018-880	021-889
VN700A1 Vulcan	1985	—	018-884	—
H2/A/B/H2C-750 Mach IV	72-75	007-955	—	002-009
KZ750B1/B2/B3/B4 (2 cylinder)	76-79	007-976	—	007-989
KZ750E1/E2/E3	80-82	—	018-880	021-889
KZ750F1 LTD Shaft	1983	—	018-880	021-889
KZ750G1 LTD (2 cylinder)	1980	007-976	—	007-989
KZ750H1/H2/H3/H4 LTD	80-83	—	018-880	021-889
KZ750K1/K2 LTD (2 cylinder)	83-84	007-956	—	007-990
KZ750L3	1983	007-956	—	007-990

## Kawasaki Street

Model	Year	Needle Valve Assy	Needle Valve	Float Bowl Gasket/O-Ring
KZ750M1 CSR (2 cylinder)	82-83	007-956	—	007-990
KZ750N1/N2 Spectre	82-83	—	018-880	021-889
KZ750R1 GPz	1982	—	—	007-990
VN750A2-A21 Vulcan 750	86-05	—	018-884	—
ZX750A1/A2/A3 GPz	83-85	007-956	—	007-990
ZX750F1/F2/F3/F4 Ninja 750R	87-90	—	018-880	021-887
ZX750H1/H2 Ninja ZX-7	89-90	—	018-880	021-888
KZ900A4/A5	76-77	007-966	—	007-994
KZ900B1 LTD	1976	007-966	—	007-994
KZ900C2 Police	1976	007-966	—	007-994
Z1A-900 (frame 00001 to 32817)	73-74	—	—	007-992
Z1A-900 (from frame 32818 on)	1974	—	—	007-993
Z1B-900	1975	—	—	007-993
ZL900A1/A2 Eliminator	85-86	—	018-880	021-887
ZX900A1/A2/A3 Ninja	84-86	—	018-880	021-887
KZ1000A1/A2	77-78	007-966	—	007-994
KZ1000A3/A3A/A4 MKII	79-80	007-966	—	007-997
KZ1000B1/B2 LTD	77-78	007-966	—	007-994
KZ1000B3/B4 LTD	79-80	007-966	—	007-997
KZ1000C1/C1A Police	1978	007-966	—	007-994
KZ1000C2/C3/C4 Police	79-81	007-966	—	007-997
KZ1000D1 Z1R	1978	007-966	—	007-994
KZ1000D3 Z1R	1980	007-966	—	007-997
KZ1000E1/E2 Shaft ST	79-80	007-966	—	007-997
KZ1000J1/J2/J3	81-83	007-956	—	007-990
KZ1000K1/K2 LTD	81-82	007-956	—	007-990
KZ1000M1/M2 CSR	81-82	007-956	—	007-990
KZ1000P1-P21 Police	82-02	007-956	—	007-990
KZ1000R1/R2 Replica	82-83	007-956	—	007-990
ZG1000A1/A2 Concours	86-87	—	018-880	021-887
ZL1000A1 Eliminator	1987	—	018-880	021-887
ZX1000A1/A2 Ninja 1000R	86-87	—	018-880	021-887
ZX1000B1/B2/B3 Ninja ZX-10	88-90	—	018-880	021-888
KZ1100A1/A2/A3 Shaft	81-83	007-956	—	007-990
KZ1100D1/D2 Spectre	82-83	007-956	—	007-990
KZ1100L1 LTD	1983	007-956	—	007-990
ZN1100B1/B2 LTD Shaft	84-85	007-956	—	007-990
ZG1200A1 Voyager XII	1986	—	018-880	021-887

## Suzuki Street

GN125Z/D	82-83	007-957	—	—
GN250Z/D/F/J	82-88	007-970	—	007-991
GS250TT/TX	80-81	007-957	—	—
GT250K Hustler	1973	—	—	002-099
GT250L/M/A/B Hustler	74-77	—	—	002-099
GS300LZ/LD	82-83	007-957	—	—
GS300LF	1985	007-957	—	—
GT380K/L/M/A/B Sebring	73-77	—	—	002-099
GN400T/XT/XX/TX/TX	80-82	—	—	007-991
GS450ED	1983	007-957	—	—
GS450GAZ/GAD Automatic	82-83	007-957	—	—
GS450GAF Automatic	1985	007-957	—	—
GS450LD	1983	007-957	—	007-990
GS450LF/LG/LH/LJ	85-88	007-957	—	007-990
GS450TXD	1983	007-957	—	007-990
GT500A/B Titan	76-77	—	—	002-099
GS550B/C/EC	77-78	007-966	—	007-994
GS550N/EN/LN	1979	007-966	—	007-994
GS550ET	1980	007-957	—	007-990
GS550LT/LX/LZ	80-82	007-957	—	007-990
GS550MZ	1982	007-957	—	007-990

# Needle Valve Sets, Needle Valves, Gaskets, & O-Rings

## Suzuki Street

Model	Year	Needle Valve Assy	Needle Valve	Float Bowl Gasket/O-Ring
GS550TX	1981	007-957	—	007-990
GT550K/L/M/A/B Indy	73-77	007-966	—	002-099
GSX600FJ/FK Katana	88-89	007-957	—	021-875
GR650D/XD Tempter	1983	007-957	—	007-990
GS650EX/EZ	81-82	007-957	—	007-990
GS650GX/GZ/GD	81-83	007-957	—	007-990
GS650GLX/GLZ/GLD	81-83	007-957	—	007-990
GS650MD Katana	1983	007-957	—	007-990
LS650FG/FH Savage	86-87	007-970	—	007-991
LS650PG/PH/PJ Savage	86-88	007-970	—	007-991
GS700EF/ESF	1985	007-957	—	007-990
GV700GLF Madura	1985	007-957	—	—
GV700GLF2 Madura	1985	007-957	—	—
GS750B/C/EC	77-78	007-966	—	007-994
GS750N/EN/LN	1979	007-966	—	007-994
GS750ET/EX/EZ	80-82	007-957	—	007-990
GS750ED/ESD	1983	007-957	—	007-990
GS750LT/LX	80-81	007-957	—	007-990
GS750TZ/TD	82-83	007-957	—	007-990
GS750SD Katana	1983	007-957	—	007-990
GSX750FK-FV Katana	89-97	—	—	021-876
GSX-R750G/H	86-87	007-957	—	021-875
GSX-R750RG	1986	007-957	—	021-875
GSX-R750J/K	88-89	—	—	021-876
GT750J/K Lemans	72-73	—	—	002-099
GT750L/M/A/B Lemans	74-77	007-976	—	007-989
GS850GN	1979	007-966	—	007-994
GS850GT/GX/GZ/GD	80-83	007-957	—	007-990
GS850GLT/GLX/GLZ/GLD	80-83	007-957	—	007-990
GS1000C/EC/N/EN	78-79	007-966	—	007-994
GS1000ET	1980	007-957	—	007-990
GS1000GT/GX	81-82	007-957	—	007-990
GS1000GLT/GLX	81-82	007-957	—	007-990
GS1000LN	1979	007-966	—	007-994
GS1000SN	1979	007-966	—	007-994
GS1000ST	1980	007-957	—	007-990
GS1000SZ Katana	1982	007-957	—	007-990
GS1100ET/EX/EZ/ED/ESD	80-83	007-957	—	007-990
GS1100GZ/GLZ/GD/GLD	82-83	007-957	—	007-990
GS1100GKZ/GK2/GKD/GKE	82-84	007-957	—	007-990
GS1100LT	1980	007-957	—	007-990
GS1100SD Katana	1983	007-957	—	007-990
GSX1100FJ-FP Katana	88-93	—	—	021-875
GSX-R1100G/H/J	86-88	007-957	—	021-875
GS1150ES3/ESE/EF/ESF	83-85	007-957	—	007-990
GS1150EF2/EG/ESG	85-86	007-957	—	007-990
GV1200GLF/GLG Madura	85-86	007-957	—	—
GV1200GLF2 Madura	1985	007-957	—	—

## Yamaha Street

RS100B/C	75-76	—	—	007-250
TA125	—	007-955	—	002-361
YAS1C-125	1968	—	—	007-282
YCS1/YCS1C (180cc)	1968	—	—	007-282
XC180DN/DNC Riva 180	1985	007-503	—	—
XC180K/KC/L/LC/N/NC	83-85	007-503	—	—
XC180ZL/ZLC/ZN/ZNC	84-85	007-503	—	—
DS6C/DS6B-250	69-70	007-958	—	002-009
DS7-250	1972	007-958	—	002-361
RD250A/B	73-75	007-955	—	007-995
SR250G/H/J Exciter	80-82	007-503	—	007-990
SR250TH Exciter II	1981	007-503	—	007-990
YDS5-250	1967	—	—	002-009

## Yamaha Street

Model	Year	Needle Valve Assy	Needle Valve	Float Bowl Gasket/O-Ring
YM2C-305	1967	—	—	002-009
R5/R5B/R5C-350	70-72	007-958	—	002-361
RD350A/B-350	73-75	007-955	—	007-995
RZ350L/N/NC/NCII	84-85	—	—	007-250
XS360C/D/2D	76-77	007-976	—	007-989
RD400C/D/E/F	76-79	007-955	—	007-995
XS400D/E/2E/F/2F	77-79	007-976	—	007-991
XS400G/H Special II	80-81	007-503	—	007-990
XS400SG/SH Special	80-81	007-503	—	007-990
XS400SJ Heritage	1982	007-503	—	007-990
XS400J Maxim	1982	007-957	—	—
XS400RJ Seca	1982	007-957	—	—
SR500E/F	78-79	—	—	007-996
TX500A	73-74	—	018-880	021-889
XS500B	1975	—	018-880	021-889
XS500C/D	76-77	007-958	—	007-989
XS500E	1978	007-976	—	007-991
XT500E/F Dual Sport	78-79	—	—	007-996
XJ550H/J/K Maxim	81-83	007-503	—	—
XJ550RH/RJ/RK Seca	81-83	007-503	—	—
XZ550RK Vision	1983	007-957	—	—
FJ600L/LC/N/NC	84-85	007-503	—	—
FZ600S/SC/T/TC/U/UC	86-88	007-504	—	—
YX600S/SC-A/AC Radian	86-90	007-504	—	—
XS1B-650	1971	007-955	—	007-989
XS2-650	1972	007-958	—	007-989
TX650A	73-74	007-958	—	007-989
XS650B/C/D/E/F	75-79	007-958	—	007-989
XS6502F	1979	007-958	—	007-989
XS650SE/SF Special	78-79	007-958	—	007-989
XS650G/H Special II	80-81	007-503	—	007-990
XS650SG/SH Special	80-81	007-503	—	007-990
XS650SJ/SK Heritage Special	82-83	007-503	—	007-990
XJ700XN/XNC Maxim X	1985	007-504	—	—
XJ700XS/XSC Maxim X	1986	007-504	—	—
<i>Maxim X with Mikuni Carbs only</i>				
TX750A	73-74	007-958	—	007-989
XS750D/2D	1977	007-976	—	007-989
XS750E/F	78-79	007-976	—	007-991
XS750SE/SF Special	78-79	007-976	—	007-991
XV750U/UC-G/GC Virago	88-95	007-980	—	—
FJ1100L/LC/N/NC	84-85	007-504	—	—
XJ1100J Maxim	1982	007-503	—	007-990
XS1100E/F	78-79	007-976	—	007-991
XS1100G/H	80-81	007-503	—	007-990
XS1100LG/LH Midnight	80-81	007-503	—	007-990
XS1100SF Special	1979	007-976	—	007-991
XS1100SG/SH Special	80-81	007-503	—	007-990
XV1100U/UC-L/LC Virago	88-99	007-980	—	—
FJ1200S/SC/T/TC	86-87	007-504	—	—

# Carburetor Float & Pin



002-114

002-605



007-727

## Sudco Mikuni Carburetor Float & Pin

Genuine Mikuni carburetor float and pin. Sold each. *Made in Japan.*

**Parts are sold separately, order by Sudco part number.**

### Kawasaki Street

Model	Year	Float	Float Pin
A7-350 Avenger 2-stroke rotary valve	66-71	002-114	002-605
A7SS-350 Avenger SS	70-71	002-114	002-605
H1D/E/F-500 2-stroke triple	73-75	002-114	002-605
KH500A8 2-stroke triple	1976	002-114	002-605
H2/A/B/C-750 2-stroke triple	72-75	002-114	002-605
KZ650H2/H3 CSR	82-83	007-727	002-605
KZ700A1	1984	007-727	002-605
H2/A/B/C-750 2-stroke triple	72-75	002-114	002-605
KZ750K1/K2 LTD (2-cylinder)	83-84	007-727	002-605
KZ750L3	1983	007-727	002-605
KZ750M1 CSR (2-cylinder)	1982	007-727	002-605
KZ750R1 GPz	1982	007-727	002-605
ZX750A1/A2/A3 GPz	83-85	007-727	002-605
KZ1000J1/J2/J3	81-83	007-727	002-605
KZ1000K1/K2 LTD	81-82	007-727	002-605
KZ1000M1/M2 CSR	81-82	007-727	002-605
KZ1000P1-P21 Police	82-02	007-727	002-605
KZ1000R1/R2 Replica	82-83	007-727	002-605
KZ1100A1/A2/A3 Shaft	81-83	007-727	002-605
KZ1100D1/D2 Spectre	82-83	007-727	002-605
KZ1100L1 LTD	1983	007-727	002-605
ZN1100B1/B2 LTD Shaft	84-85	007-727	002-605

### Suzuki Street

GS250TT/TX	80-81	007-727	002-605
GS300LZ/LD	82-83	007-727	002-605
GS300LF	1985	007-727	002-605
GS450ED	1983	007-727	002-605
GS450GAF/GAD Automatic	82-83	007-727	002-605
GS450GAF Automatic	1985	007-727	002-605
GS450LD	1983	007-727	002-605
GS450LD/LF/LG/LH/LJ	85-88	007-727	002-605

### Suzuki Street

Model	Year	Float	Float Pin
GR650D/XD Tempter	1983	007-727	002-605
GS650EX/EZ	81-82	007-727	002-605
GS650GX/GZ/GD	81-83	007-727	002-605
GS650GLX/GLZ/GLD	81-83	007-727	002-605
GS650MD Katana	1983	007-727	002-605
GS700EF/ESF	1985	007-727	002-605
GS750ET/EX/EZ	80-82	007-727	002-605
GS750ED/ESD	1983	007-727	002-605
GS750LT/LX	80-81	007-727	002-605
GS750SD Katana	1983	007-727	002-605
GS750TZ/TD	82-83	007-727	002-605
GS850GT/GX/GZ/GD	80-83	007-727	002-605
GS850GLT/GLX/GLZ/GLD	80-83	007-727	002-605
GS1000ET	1980	007-727	002-605
GS1000GT/GX	80-81	007-727	002-605
GS1000GLT/GLX	80-81	007-727	002-605
GS1000ST	1980	007-727	002-605
GS1000SZ Katana	1982	007-727	002-605
GS1100ET/EX/EZ	80-82	007-727	002-605
GS1100ED/ESD	1983	007-727	002-605
GS1100GKZ/GK2/GKD/GKE	82-84	007-727	002-605
GS1100GLZ/GLD	82-83	007-727	002-605
GS1100LT	1980	007-727	002-605
GS1100SD	1983	007-727	002-605
GS1150ES3/ESE/EF/ESF/EF2	83-85	007-727	002-605
GS1150/EG/ESG	1986	007-727	002-605

### Yamaha Street

SR250G/H/J Exciter	80-82	007-727	002-605
SR250TH Exciter II	1981	007-727	002-605
XS400J/K Maxim	82-83	007-727	002-605
XS400RJ/RK Seca	82-83	007-727	002-605
FJ600L/LC/N/NC	84-85	007-727	002-605
XS1/XS1B/XS2-650	70-72	002-114	002-605
TX650/A	73-74	002-114	002-605
XS650B/C/D/E/F	75-79	002-114	002-605
XS6502F	1979	002-114	002-605
XS650H Special II	1981	007-727	002-605
XS650SE/SF Special	78-79	002-114	002-605
XS650SH Special	1981	007-727	002-605
XS650SJ/SK Heritage Special	82-83	007-727	002-605
XJ700XN/XNC/XS/XSC Maxim X	85-86	007-727	002-605
XJ900RK Seca	1983	007-727	002-605
FJ1100L/LC/N/NC	84-85	007-727	002-605
XJ1100J Maxim	1982	007-727	002-605
XS1100H	1981	007-727	002-605
XS1100LH Midnight Special	1981	007-727	002-605
XS1100SH Special	1981	007-727	002-605
FJ1200S/SC/T/TC	86-87	007-727	002-605
FJ1200W/WC/A/AC/B/BC/D/DC	89-92	007-727	002-605
FJ1200AD/ADC/AE/AEC (ABS)	92-93	007-727	002-605

# Keihin Type Press-Fit Main Jets

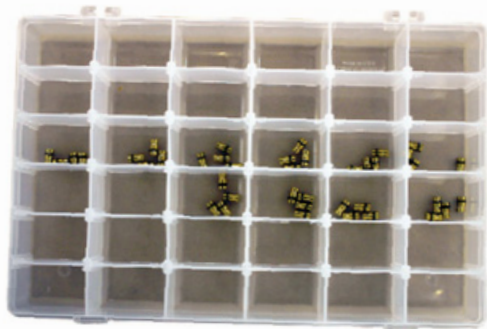

## Sudco Keihin Type Press-Fit Primary Main Jets

KEYSTER brand, aftermarket type jets.  
Dealer kit includes qt 4 jets of sizes listed below.  
(total 44 jets) with storage box. **Made in Japan.**



**Keihin Type Press-Fit Primary Main Jet Kit** Order No. **026-090**  
Includes storage box and qt 4 each of the following size: #60, #62, #65, #68, #70, #72, #75, #82, #88, #90, #92

**Keihin Type Press Fit Primary Main Jets with O-Ring**  
**Sold each.**

Size	Order No.	OEM Ref	Size	Order No.	OEM Ref
#60	<b>026-010</b>	99201-601-0600	#75	<b>026-016</b>	99201-601-0750
#62	<b>026-011</b>	99201-601-0620	#82	<b>026-017</b>	99201-601-0820
#65	<b>026-012</b>	99201-601-0650	#88	<b>026-018</b>	99201-601-0880
#68	<b>026-013</b>	99201-601-0680	#90	<b>026-019</b>	99201-601-0900
#70	<b>026-014</b>	99201-601-0700	#92	<b>026-020</b>	99201-601-0920
#72	<b>026-015</b>	99201-601-0720			

## Sudco Keihin Type Press-Fit Secondary Main Jets

KEYSTER brand, aftermarket type jets.  
Dealer kit includes qt 4 jets of sizes listed below.  
(total 68 jets) with storage box. **Made in Japan.**

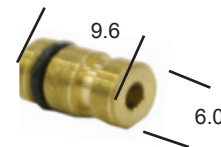

**Keihin Type Press-Fit Secondary Main Jet Kit** Order No. **026-091**  
Includes storage box and qt 4 each of the following size: #68, #70, #72, #75, #78, #80, #98, #100, #105, #110, #115, #120, #125, #130, #135, #140, #150

**Keihin Type Press Fit Secondary Main Jets with O-Ring**  
**Sold each.**

Size	Order No.	OEM Ref	Size	Order No.	OEM Ref
#68	<b>026-043</b>	99202-601-0680	#110	<b>026-054</b>	99202-601-1100
#70	<b>026-044</b>	99202-601-0700	#115	<b>026-055</b>	99202-601-1150
#72	<b>026-045</b>	99202-601-0720	#120	<b>026-056</b>	99202-601-1200
#75	<b>026-046</b>	99202-601-0750	#125	<b>026-057</b>	99202-601-1250
#78	<b>026-047</b>	99202-601-0780	#130	<b>026-058</b>	99202-601-1300
#80	<b>026-048</b>	99202-601-0800	#135	<b>026-059</b>	99202-601-1350
#98	<b>026-051</b>	99202-601-0980	#140	<b>026-060</b>	99202-601-1400
#100	<b>026-052</b>	99202-601-1000	#150	<b>026-062</b>	99202-601-1500
#105	<b>026-053</b>	99202-601-1050			

## Honda

Model	Year
CB350G Super Sport	1973
CB350K0/K1/K2/K3/K4	68-73
CL350K0/K1/K2/K3/K4/K5	68-73
GL1000K Goldwing	75-79
GL1000L Goldwing LTD	1976

## Honda

Model	Year
CB350F/F1 Super Sport	72-74
CB350G Super Sport	1973
CB350K0/K1/K2/K3/K4	68-73
CL350K0/K1/K2/K3/K4/K5	68-73
CB400F Super Sport	75-77
CB500K0/K1/K2	71-73
CB550F Super Sport	75-77
CB550K0/K1	74-75
CB550K	1976
GL1000K Goldwing	75-79
GL1000L Goldwing LTD	1976

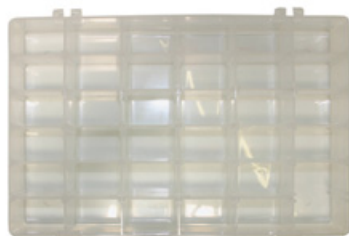

008-001



008-002

## Sudco Plastic Jet Boxes (Storage Boxes)

Two boxes available, 36 compartment and 18 compartment.  
Use for valve shim storage, small parts, electrical connectors and carburetor jets. Sold each.

Description	Order No.
Jet Box with 36 Compartments 7-1/2" L x 10-1/2" L x 1-1/4" H	<b>008-001</b>
Jet Box with 18 Compartments 3-1/4" L x 6-3/4" L x 1-1/2" H	<b>008-002</b>

## Kawasaki

Model	Year
KZ400A1 Deluxe	1977
KZ400/D/D3/D4	74-77
KZ400S/S2/S3 Special	75-77

## Yamaha

Model	Year
TX500/A	73-74
XS500B	1975

## Keihin Slow & Main Jets

OEM (genuine) jets. **Made in Japan.**  
**See Intake section, page 148-151 for sizes.**



## Sudco Hitachi Type Main & Pilot Jets

KEYSTER brand, aftermarket screw-in type jets for Yamaha applications. Dealer kit includes qt 4 jets of sizes listed below. (total 56 jets) with storage box. **Made in Japan.**

**Hitachi Type Main & Pilot Jet Kit** Order No. **026-190**

Includes storage box and qt 4 each size of the following:

Main Jets: #110, #112, #116, #118, #120, #122, #124, #126, #128, #130, #132, #134, Pilot Jets: #40, #41

### Hitachi Type Main Jets Sold each.

Size	OEM Reference	Order No.
#110	4H7-14925-10-00	026-110
#112	4H7-14925-12-00	026-112
#116	4H7-14925-16-00	026-113
#118	4H7-14925-18-00	026-114
#120	4H7-14925-20-00	026-115
#122	4H7-14925-22-00	026-116
#124	4H7-14925-24-00	026-117
#126	4H7-14925-26-00	026-118
#128	4H7-14925-28-00	026-119
#130	4H7-14925-30-00	026-120
#132	4H7-14925-32-00	026-121
#134	4H7-14925-34-00	026-122

### Hitachi Type Pilot Jets Sold each.

Size	OEM Reference	Order No.
#40	4X7-14984-40-00	026-145
#41	4X7-14984-41-00	026-146

## Yamaha

Model	Year
XJ650G/H/J/K Maxim	80-83
XJ650LH Midnight Maxim	1981
XJ650RJ Seca	1982
XJ700N/NC/S/SC Maxim	85-86
XJ750RH/RJ/RK Seca	81-83
XV700L/LC/N/NC Virago	84-85
XV700CS/CSC/CT/CTC Virago	86-87
XV700SS/SSC Virago	1986
XJ750J/K Maxim	82-83
XJ750MK Midnight Maxim	1983
XV750H/J/K Virago	81-83
XV750MK Midnight Virago	1983
XV920J/K Virago	82-83
XV920MK Midnight Virago	1983
XV920RH/RJ Euro	81-82
XV1000L/LC/N/NC	84-85
XV1100S/SC/T/TC Virago	86-87

## Sudco Hitachi Type Needle Valve Assemblies

KEYSTER brand, aftermarket type needle valve assemblies for Yamaha applications. Sold each. **Made in Japan.**

Application	OEM Reference	Order No.
XS850 (80-81)	3J3-W1496-20-00	026-300
XJ650/XJ750/XV750/XV920	10L-14390-02-00	026-302
see 10L-14390-02-00	42H-14390-00-00	026-302

## Sudco Hitachi Float Bowl Gaskets

Aftermarket type for Yamaha applications. Sold each. **Made in Japan.**

Application	OEM Reference	Order No.
XJ650/XJ750 (80-83)	4H7-14984-01-00	026-320
XV750 (81-83),XV920 (1982)	4X7-14984-01-00	026-322
XV1000 (84-85)	10L-14984-01-00	026-324
XS850 (80-81)	3J3-14984-00-00	026-326

## Yamaha

Model	Year	Needle Valve	Float Bowl Gasket
XJ650G/H/J/K Maxim	80-83	026-302	026-320
XJ650LH Midnight Maxim	1981	026-302	026-320
XJ650RJ Seca	1982	026-302	026-320
XJ700N/NC Maxim	1985	026-302	026-320
XJ700S/SC Maxim	1986	026-302	026-320
XJ750J/K Maxim	82-83	026-302	026-320
XJ750MK Midnight Maxim	1983	026-302	026-320
XJ750RH/RJ/RK Seca	81-83	026-302	026-320
XV750H/J/K Virago	81-83	026-302	026-322
XV750MK Midnight Virago	1983	026-302	026-322
XS850G/H	80-81	026-300	026-326
XS850LG/LH Midnight Special	80-81	026-300	026-326
XS850SG/SH Special	80-81	026-300	026-326
XV920J Virago	1982	026-302	026-322
XV920K Virago	1983	026-302	026-324
XV920MK Midnight Virago	1983	026-302	026-324
XV920RH/RJ	81-82	026-302	026-322
XV1000L/LC/N/NC Virago	84-85	026-302	026-324
XV1100S/SC/T/TC Virago	86-87	026-302	026-324



## Mikuni Pilot & Main Jets

OEM (genuine) jets. **Made in Japan.**

See Intake section, page 212-215 for sizes.

# Carb Pump Diaphragm Valve Sets



007-783



007-782



007-785



007-781

## K&L Carb Pump Diaphragm Valve Sets

Each set contains one diaphragm with rod attached, one rubber boot for rod, spring and o-ring as required. Sold as a set, three or four piece as noted. **Made in Japan.**

### Honda

**OEM Reference** 16021-ME2-771 (4 pc. set) **Order No. 007-783**  
1602-MG1-671 - Diaphragm with 55.60mm long rod, spring, rubber boot for rod, and o-ring for passageway.

Model	Year
CX650C	1983
GL650	1983
GL650I	1983
CB1000C	1983
CB1100F Super Sport	1983

**OEM Reference** 16021-679-005 (3 pc. set) **Order No. 007-782**  
Diaphragm with 54.01mm long rod, spring, rubber boot for rod.

Model	Year
CB750C Custom	80-82
CB750F Super Sport	79-82
CB750K	79-82
CB750L LTD	1979
CB750SC Nighthawk 750	82-83
CB900C Custom	80-82

**OEM Reference** 16021-MW8-000 (3 pc. set) **Order No. 007-785**

16021-MN5-0074, 16021-MT8-000, 16021-MAM-A80  
Diaphragm with 31.31mm long rod, spring, rubber boot for rod.

Model	Year
GL1500 Goldwing	88-90
GL1500A Goldwing Aspencade	91-00
GL1500I Goldwing Interstate	91-96
GL1500SE Goldwing SE	90-00



007-784

**OEM Reference** 16021-422-004 (3 pc. set) **Order No. 007-784**  
Diaphragm with 50.88mm long rod, spring, rubber boot for rod.

Model	Year
CBX1000 (1047cc) Super Sport	79-82

### Honda

**OEM Reference** 16021-413-751 (4 pc. set) **Order No. 007-781**  
16021-438-671, 16021-463-004 - Diaphragm with 54.13mm long rod, spring, rubber boot for rod.

Model	Year
CM250C Custom	1983
CB400T Hawk	80-81
CM400A Automatic	80-81
CM400C Custom	1981
CM400E	80-81
CM400T	80-81
CB450SC Nighthawk	1982
CB450T Hawk	1982
CM450C Custom	1982
CM450E	1982
CX500C Custom	80-82
CX500D Deluxe	80-81
GL500 Silverwing	81-82
GL500I Silverwing Interstate	81-82
CB900F Super Sport	81-82
GL1100 Goldwing	80-83
GL1100A Goldwing Aspencade	82-83
GL1100I Goldwing Interstate	80-83



007-780

**OEM Reference** 16021-MC9-771 (3 pc. set) **Order No. 007-780**

16021-393-004, 16021-393-014 - Diaphragm with 89.46mm long rod, spring, rubber boot for rod.

Model	Year
CB450SC Nighthawk	1983
CB450SC Nighthawk	85-86
CM450E	1983
CB750A Automatic	76-78
CB750F Super Sport	77-78
CB750K	77-78



# Accel. Pump Rebuild Kit & Air Cut-Off Valve Set

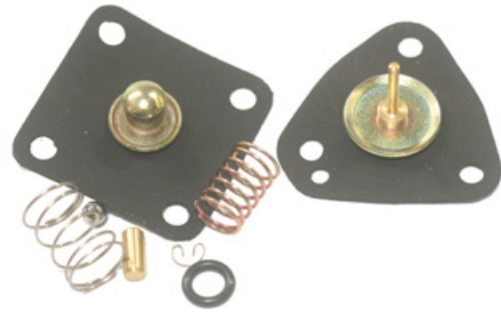

## K&L Air Cut-Off Valve Set (Non Genuine)

This high quality set from K&L includes diaphragm, spring and o-ring.  
Honda Reference for kit: 16048-429-771, 16029-429-671. **Made in Japan.**

Order No. **018-901**

### Honda

Qt	OEM Reference	Description
1		Diaphragm
1		Spring
1		"U-Ring" O-ring

### Applications

Applications	Year
XL250S Dual Sport	80-81
CB400T Hawk	80-81
CM400A Automatic	80-81
CM400C Custom	1981
CM400E	80-81
CM400T	80-81
CB450T Hawk	1982
CM450A Automatic	82-83
CM450C Custom	1982
CM450E	82-83
CX500C Custom	80-82
CX500D Deluxe	80-81
GL500 Silverwing	81-82
GL500I Silverwing Interstate	81-82
CB650	1980
CB650C Custom	1980
CB750C Custom	80-82
CB750F Super Sport	80-82
CB750K	80-82
CB750SC Nighthawk	82-83
CB900C Custom	80-82
CB900F Super Sport	81-82
GL1100	80-83
GL1100A Goldwing Aspencade	82-83
GL1100I Goldwing Interstate	80-83

See Intake section, page 232-235 for additional models.

## K&L Accelerator Pump Rebuild Kit

Eight piece kit fits Kawasaki Vintage KZ650/KZ1000 models listed from 1979-1981. **Made in Japan.**

Order No. **018-863**

### Kawasaki OEM Mikuni VM Carburetor

Qt	OEM Reference	Description
Qt.1	43028-1112	Carb Pump Diaphragm (square)
Qt.1	43028-1010	Carb Pump Sensor Diaphragm (rectangular)
Qt.1	92081-1137	Carb Pump Sensor Diaphragm Spring
Qt.1	92081-1139	Carb Pump Diaphragm Spring
Qt.1	16038-016	Check Valve O-ring
Qt.1	92037-1123	Check Valve Clamp Spring (clip)
Qt.1	13042-1004	Check Valve Weight
Qt.1	92140-1003	Check Valve Ball (steel)

### Applications, Kawasaki OEM Mikuni VM only

Applications, Kawasaki OEM Mikuni VM only	Year
KZ650B3/C3/D2	1979
KZ650E1 LTD	1980
KZ650F1	1980
KZ650H1 CSR	1981
KZ1000A3/A3A/A4 MKII	79-80
KZ1000B3/B4 LTD	79-80
KZ1000C2/C3/C4 Police	79-81
KZ1000D3 Z1R	1980
KZ1000E1/E2 Shaft ST	79-80



# Carb Slide Diaphragms



007-771



007-773



007-775



007-772



007-774

## Sudco Mikuni Carb Slide Diaphragms

GENUINE Mikuni Carb Slide Diaphragms for vintage Yamaha models listed. Fits OEM carburetors. **Made in Japan.** Sold each.

### Yamaha

*Carb Slide Diaphragm 41R-14940-09-00,* **Order No. 007-775**

Model	Year
XV535A/AC Virago	1990
XV535E/EC/F/FC/G/GC Virago	93-95
XV535H/HC/J/JC Virago	96-97
XV535SF/SFC/SG/SGC Virago	94-95
XV535SH/SHC/SJ/SJC/SK/SKC Virago	96-98
XV535L/LC/M/MC Virago 535	99-00
XVZ12TK/L/KC2 Venture	83-84
XVZ12TDK Venture Royale	198
XVZ12DN Venture Royale	1985

*Carb Slide Diaphragm 50H-14940-00-00,* **Order No. 007-773**

FJ1100N	1985
FJ1200S/SC/T/TC	86-87
FJ1200W/WC/A/AC/B/BC/D/DC	89-92
FJ1200AD/ADC/AE/AEC (ABS)	92-93

*Carb Slide Diaphragm 256-14940-00-00,* **Order No. 007-774**  
*256-14940-01-00*

XS500C/D	76-77
XS1/XS1-B/XS2-650	70-72
TX650/A	73-74
XS650B/C/D	75-77



007-770

## Yamaha

*Carb Slide Diaphragm 2F3-14940-00-00,* **Order No. 007-770**  
*2A2-14940-00-00*

Model	Year
XS400D/E/2E/F/2F	77-79
XS750E/F	78-79
XS750SE/SF Special	78-79
XS1100E/F	78-79
XS1100SF Special	1979

*Carb Slide Diaphragm 1FK-14940-09-00* **Order No. 007-771**

VMX12N/NC/S/SC V-Max	85-86
VMX12U/UC/W/WC/A/AC/B/BC V-Max	88-91
VMX12D/DC/E/EC/F/FC/G/GC V-Max	92-95
VMX12H/HC/J/JC/K/KC/L/LC V-Max	95-99
VMX12M/MC/N/NC/P/PC/R/S/SC V-Max	00-04
VMX12T/TC/V/VC/W1/W1C V-Max	05-07
XVZ13T/TC/U/UC Venture	87-88
XVZ13DS/DSC/DT/DTC Venture Royale	86-87
XVZ13DU/DUC/DW/DWC Venture Royale	88-89
XVZ13DA/DAC/DB/DBC Venture Royale	90-91
XVZ13DD/DDC/DE/DEC Venture Royale	92-93

*Carb Slide Diaphragm 3F7-14940-00-00,* **Order No. 007-772**  
*3H5-14940-00-00*

SR250G/H/J Exciter	80-82
SR250TH Exciter	1981
XS650G/H Special II	80-81
XS650SG/SH Special	80-81
XS650SJ/SK Heritage Special	82-83
XJ900RK Seca	1983
XJ1100J Maxim	1982
XS1100G/H	80-81
XS1100LG/LH Midnight Special	80-81
XS1100SG/SH Special	80-81

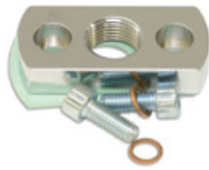

Adapter Plate



Adapter Nut



Power-Flo Fuel Valve

## Pingel Power-Flo™ Fuel Valves

Pingel® Fuel Valves provide more fuel flow than OEM petcock. This is a must with drag, racing and high performance vintage applications. Manufactured from billet with high quality stainless steel components. Power-Flo™ fuel valves feature highly polished aluminum or highly polished chrome-plated brass finishes with either 1/4" NPT, 3/8" NPT or HD metric thread 22mm. 5/16" outlet in single, dual or triple with or without reserve. Fuel Valves listed sold each. **Note: See page 262-263 for additional details.**

### Honda

Model	Year	Fuel Valve Pingel No.	Reserve	Outlet 5/16"	Order No.	Description/Notes	Adapter Pingel No.	Order No.
CB1100F Super Sport	1983	6111-AH	Yes	Single	009-307	Adapter Nut required	A2000C	009-370
CBX	79-81	6111-AH	Yes	Single	009-307	Adapter Nut required	A2003C	009-371
CBX	1982	6111-AH	Yes	Single	009-307	Adapter Nut required	A2000C	009-370

### Kawasaki

S1A/S1B/S1C-250	73-75	8210T-AH	No	Triple	009-316	Adapter Nut required	A2001C	009-365
KH250A5	1976	8210T-AH	No	Triple	009-316	Adapter Nut required	A2001C	009-365
S2/S2A-350	72-73	8210T-AH	No	Triple	009-316	Adapter Nut required	A2001C	009-365
S3/S3A-400	74-75	8210T-AH	No	Triple	009-316	Adapter Nut required	A2001C	009-365
KH400A3/A4/A5	76-78	8210T-AH	No	Triple	009-316	Adapter Nut required	A2001C	009-365
H1/H1A/H1B/H1C-500	69-72	8210T-AH	No	Triple	009-316	Adapter Nut required	A2002C	009-366
H2/H2A/H2B/H2C-750	72-75	8210T-AH	No	Triple	009-316	Adapter Nut required	A2002C	009-366
Z1/A/B-900, KZ900A4/A5	73-77	6311-AH		Single	009-302	Adapter included	---	---
KZ1000 w/thread on valve		6311-AH		Single	009-302	Adapter included	---	---
		3311-D-AH		Dual	009-334	Adapter included	---	---
KZ1000/1100 w/bolt-on vlve		6211-AH		Single	009-305	Adapter Plate required	A1702C	009-352
		3211-D-AH		Dual	009-311	Adapter Plate required	A1702C	009-352
KZ1300A	79-82	6211-AH	Yes	Single	009-305	Adapter Plate required	A1702C	009-352

### Suzuki

GS750/1000/1100E	79-83	6211-AH		Single	009-305	Adapter Plate required	A1702C	009-352
		3211-D-AH		Dual	009-311	Adapter Plate required	A1902C	009-357
GS1150E	84-85	6211-AH		Single	009-305	Adapter Plate required	A1702C	009-352
		3211-D-AH		Dual	009-311	Adapter Plate required	A1902C	009-357

For Suzuki models listed, order adapter plate required.



## Sudco Fuel & Vacuum Hose Clips

OEM sized fuel and vacuum hose clips. Sold pk/5.  
*Made in Japan.*

Description	Order No.
1/4" (6mm) I.D.	009-090
9/32" (7mm) I.D.	009-091
5/16" (8mm) I.D.	009-092
3/8" (9mm) I.D.	009-093

## Fuel Line, Vent Hose, Primer Hose & Fuel Filters

See Intake Section, page 268-269.



## Fuel Petcock Diaphragm Set **NEW**

Set includes diaphragm and seals. Fits Kawasaki H1-500 and H2 750 vintage 2-stroke triple models.

Order No. 009-490

# Fuel Petcock Repair Kits



009-405



009-402

## K&L Fuel Petcock Repair Kits

Kit contains all necessary o-rings and diaphragms to rebuild one fuel petcock. Sold in kits. **Made in Japan.** Note: Does not include plastic diaphragm spacer block.

### Honda Street

Model	Year	Fuel Petcock Repair Kit	Diaphragm Only
VTR250 Interceptor	88-90	009-405	—
CB450SC Nighthawk	85-86	009-405	—
CMX450C Custom	86-87	009-405	—
CX500C Custom	81-82	009-405	—
CX500D Deluxe	81-82	009-405	—
FT500 Ascot	82-83	009-405	—
GL500I Silverwing Interstate	81-82	009-405	—
VT500C Shadow	83-86	009-405	—
VT500FT Ascot	1984	009-405	—
CB550SC Nighthawk	1983	009-405	—
XL600V Transalp	89-90	009-405	—
CB650SC Nighthawk	83-85	009-405	—
CX650C Custom	1983	009-405	—
GL650I Silverwing Interstate	1983	009-405	—
CB700SC Nighthawk	84-86	009-405	—
VF700S Sabre	84-85	009-405	—

### Kawasaki Street

S1A/B/C-250 (two stroke triple)	73-75	009-414	—
KH250A5 (two stroke triple)	1976	009-414	—
S2/A-350 (two stroke triple)	72-73	009-414	—
S3/A-400 (two stroke triple)	74-75	009-414	—
KH400A3/A4 (two stroke triple)	76-77	009-414	—
KZ550A1/A2/A3/A4	80-83	009-402	009-501
KZ550C1/C2/C3/C4 LTD	80-83	009-402	009-501
KZ550D1 GPz	1981	009-402	009-501
KZ550F1/F2 Spectre & LTD	83-84	009-421	009-502
KZ550H1/H2 GPz	82-83	009-421	009-502
KZ550M1 LTD	1983	009-421	009-502
ZR550B1/B2	90-91	009-435	009-506
ZR550B3/B4 (Canadian models)	92-93	009-435	009-506
ZX550A1/A2 GPz	84-85	009-421	009-502
KZ650B3	1979	009-403	009-500
KZ650E1/F1	1980	009-403	009-500
KZ650H1 CSR	1981	009-402	009-501
KZ650H2/H3 CSR	82-83	009-403	009-500
KZ700A1	1984	009-403	009-500
VN700A1 Vulcan	1985	009-421	009-502
ZN700A1/A2 LTD	84-85	009-421	009-502
KZ750B1/B2/B3/B4 (2 cylinder)	76-79	009-414	—
KZ750E1/E2/E3	80-82	009-403	009-500
KZ750F1 LTD	1983	009-421	009-502
KZ750G1 LTD (2 cylinder)	1980	009-414	—
KZ750H1/H2/H3/H4 LTD	80-83	009-403	009-500
KZ750K1 LTD (2 cylinder)	1983	009-402	009-501

## Kawasaki Street

Model	Year	Fuel Petcock Repair Kit	Diaphragm Only
KZ750K2 LTD (2 cylinder, Canadian model)	1984	009-402	009-501
KZ750L3	1983	009-403	009-500
KZ750M1 CSR (2 cylinder)	1982	009-402	009-501
KZ750N1/N2 Spectre	82-83	009-421	009-502
KZ750R1 GPz	1982	009-403	009-500
ZR750C1/C2	91-92	009-435	009-506
ZR750C3 (Canadian model)	1993	009-435	009-506
ZR750F2 ZR-7	2000	009-435	009-506
ZX750A1/A2/A3 GPz	83-85	009-403	009-500
Z1/A/B-900	73-75	009-414	—
KZ900A4/A5	76-77	009-414	—
KZ900B1 LTD	1976	009-414	—
ZL900A1/A2 Eliminator	85-86	009-408	009-500
ZX900A1/A2/A3 Ninja	84-86	009-403	009-500
KZ1000A1	1977	009-414	—
KZ1000A2/A2A	1978	009-413	—
KZ1000A3/A3A/A4 MKII	79-80	009-413	—
KZ1000B1/B2/B3/B4 LTD	77-80	009-414	—
KZ1000C1 Police (manual petcock)	1978	009-414	—
KZ1000C1A-C4 Police (vacuum petcock)	78-81	009-413	—
KZ1000D1 Z1R	1978	009-414	—
KZ1000D3 Z1R	1980	009-414	—
KZ1000E1/E2 Shaft ST	79-80	009-407	—
KZ1000G1 LTD Classic	1980	009-414	—
KZ1000J1/J2	81-82	009-407	—
KZ1000K1/K2 LTD	81-82	009-403	009-500
KZ1000M1/M2 CSR	81-82	009-403	009-500
KZ1000P1-P21 Police	82-02	009-403	009-500
KZ1000P24 Police	2005	009-403	009-500
KZ1000R1/R2 Replica	82-83	009-407	—
ZG1000A1-A20 Concours	86-05	009-408	009-500
ZL1000A1 Eliminator	1987	009-408	009-500
ZX1000A1/A2 Ninja 1000R	86-87	009-408	009-500
KZ1100A1/A2/A3 Shaft	81-83	009-407	—
KZ1100D1/D2 Spectre	82-83	009-403	009-500
KZ1100L1 LTD	1983	009-403	009-500
ZN1100B1/B2 LTD 1100	84-85	009-403	009-500
ZX1100A1/A2 GPZ	83-84	009-414	—

## Suzuki Street

GS300LZ/LD	82-83	009-475	009-503
GS300LF	1985	009-475	009-503
GS400B/XB/C/XC	77-78	009-479	009-504
GS425N/EN/LN	1979	009-479	009-504
GS450ED	1983	009-475	009-503
GS450GAZ/GAD Automatic	82-83	009-475	009-503
GS450GAF Automatic	1985	009-475	009-503
GS450LD	1983	009-475	009-503
GS450LF/LG/LH/LJ	85-88	009-475	009-503

## Suzuki Street

Model	Year	Fuel Petcock Repair Kit	Diaphragm Only
GS450TX/TZ	81-82	009-475	009-503
GS450TXZ/TXD	82-83	009-475	009-503
GS550ES3/ESE/EF/ESF/ESG	83-86	009-475	009-503
GS550LT	1980	—	009-504
GS550LX/LZ	81-82	009-475	009-503
GS550LF/LG	85-86	009-475	009-503
GS550MZ Katana	1982	009-475	009-503
GS550TX	1981	009-475	009-503
GR650D/XD Tempter	1983	009-475	009-503
GS650EX/EZ	81-82	009-475	009-503
GS650GX/GZ/GD	81-83	009-475	009-503
GS650GLX/GLZ/GLD	81-83	009-475	009-503
GS650MD Katana	1983	009-475	009-503
GS700EF/ESF	1985	009-475	009-503
GS750B/C/EC/N/EN	77-79	009-479	009-504
GS750ET	1980	—	009-504
GS750EX/EZ/ED/ESD	81-83	009-475	009-503
GS750LT	1980	—	009-504
GS750LX	1981	009-475	009-503
GS750SD Katana	1983	009-475	009-503
GS750TZ/TD	82-83	009-475	009-503
GSX-R750RG	1986	009-475	009-503
GSX-R750G/H	86-87	009-475	009-503
GS850GN/GT/GX	79-81	009-479	009-504
GS850GLT	1980	—	009-504
GS850GLX/GLZ/GLD	81-83	009-475	009-503
GS1000C/EC/N/EN/SN	78-79	009-479	009-504
GS1000ET	1980	—	009-504
GS1000GT/GX	80-81	009-479	009-504
GS1000GLT	1980	—	009-504
GS1000GLX	1981	009-475	009-503
GS1000ST	1980	—	009-504
GS1000SZ	1982	009-475	009-503
GS1100ET	1980	—	009-504
GS1100EX/EZ/ED/ESD	81-83	009-475	009-503
GS1100GZ/GLZ/GD/GLD	82-83	009-475	009-503
GS1100GKZ/GK2/GKD/GKE	82-84	009-475	009-503
GS1100LT	1980	—	009-504
GS1100SD Katana	1983	009-475	009-503
GSX1100FJ/FK/FL/FM/FN/FP Katana	88-93	009-440	009-509
GSX-R1100G/H/J	86-88	009-475	009-503
GSX-R1100K/L/M/N	89-92	009-480	009-504
GS1150ES3/ESE/EF/ESF	83-85	009-475	009-503

## Yamaha Street

SR250G/H/J Exciter	80-82	009-402	009-501
SR250TH Exciter	1981	009-402	009-501
XS360C/D/2D	76-77	009-400	009-504
XS400D	1977	009-400	009-504
XS400E/F/2F/G/H	78-81	009-403	009-500
XS400SG/SH Special	80-81	009-403	009-500
XS400J/K Maxim	82-83	009-402	009-501
XS400RJ/RK Seca	82-83	009-402	009-501
SR500E/F/G/H	78-81	009-400	009-504
XS500E	1978	009-400	009-504
XV535A/AC Virago	1990	009-443	—
XV535E/EC-L/LC Virago	93-99	009-443	—
XV535SF/SFC-SJ/SJC Virago	94-97	009-443	—
XJ550H/J/K Maxim	81-83	009-402	009-501
XJ550RH/RJ/RK Seca	81-83	009-402	009-501
XZ550RJ/RK Vision	82-83	009-402	009-501
FJ600L/LC/N/NC	84-85	009-402	009-501

## Yamaha Street

Model	Year	Fuel Petcock Repair Kit	Diaphragm Only
FZ600S/SC/T/TC/U/UC	86-88	009-427	009-506
FZR600W/WC/A/AC*	89-90	009-424	—
FZR600RA/RAC-RL/RLC*	90-99	009-424	—
SRX600S/SC	1986	009-402	009-501
XJ650G/H/J/K Maxim	80-83	009-402	009-501
XJ650LH Midnight Maxim	1981	009-402	009-501
XJ650RJ Seca	1982	009-402	009-501
XS650E	1978	009-400	009-504
XS6502F	1979	009-403	009-500
XS650G/H Special II	80-81	009-403	009-500
XS650SH/SJ/SK Heritage	81-83	009-403	009-500
XJ700N/NC/S/SC Maxim	85-86	009-403	009-500
XJ700XN/XNC/XS/XSC Maxim X	85-86	009-403	009-500
XV700L/LC/N/NC Virago	84-85	009-402	009-501
XV700CS/CSC/CT/CTC Virago	86-87	009-402	009-501
XV700SS/SSC Virago	1986	009-402	009-501
XJ750RH/RJ/RK Seca	81-83	009-402	009-501
XS750D/2D/E/F	77-79	009-400	009-504
XS750SE after frame no. 311211	1978	009-403	009-500
XS750SF	1979	009-403	009-500
XV750H/J/K Virago	81-83	009-402	009-501
XV750MK Midnight Virago	1983	009-402	009-501
XV750U/UC-K1/KC1 Virago	88-98	009-442	—
XS850SG/SH Special	80-81	009-403	009-500
XJ900RK Seca	1983	009-403	009-500
XV920J/K Virago	82-83	009-402	009-501
XV920MK Midnight Virago	1983	009-402	009-501
XV920RH/RJ/RK	81-83	009-402	009-501
XS1100E/F/G/H	78-81	009-400	009-504



## Honda Fuel Petcock **NEW**

Fuel Petcock for vintage Honda 2-cyl. models. Sold each. Replaces Honda OEM 16950-292-000.

Order No. **009-382**

## Honda

Model	Year
CL175K4/K5 Scrambler 175	70-71
CB350G Super Sport	1973
CB350K0/K1/K2/K3/K4	68-73
CL350K0/K1/K2/K3/K4/K5	68-73
SL350K0/K1/K2 Moto Sport 350	70-72
CB360	1974
CB360G	1973
CL360/K1 Scrambler 360	74-75
CB450K0-K7 Super Sport 450	66-74
CL450K0-K6	67-74

# Engine Gasket Sets



608-056

## Vesrah Engine Gasket Sets

Gasket sets are available in complete and top end sets for the models listed. **Made in Japan** to OEM specifications. For models not listed, see Engine section. **Please call for availability.**

### Honda Street

Model	Year	Complete	Top End
CB92 Benley Super Sport 125	59-62	608-140	_____
CB92R Benley Super Racer 125	61-62	608-140	_____
CB72 Hawk 250	61-66	608-160	_____
CL72 Scrambler 250		608-160	_____
CB77 305 Super Hawk 305	61-68	608-162	_____
CL77 Scrambler 305	65-68	608-162	_____
CB350G	1973	608-012	_____
CB350/K1-K4 Super Sport	68-73	608-012	_____
CL350/K1-K5 Scrambler	68-73	608-012	_____
SL350/K1/K2 Moto Sport	70-72	608-012	_____
CB400A Automatic	1978	608-053	_____
CB400F Super Sport	75-77	608-170	_____
CB400T1 Hawk	78-79	608-053	_____
CB400TII Hawk	78-79	608-053	_____
CB400T Hawk	80-81	608-053	_____
CM400A Automatic	79-81	608-053	_____
CM400C Custom	1981	608-053	_____
CM400E	80-81	608-053	_____
CM400T	79-81	608-053	_____
CB450K1-K7 Super Sport	68-74	608-0152	_____
CL450K1-K6 Scrambler	68-74	608-0152	_____
CX500	78-79	608-052	_____
CX500C Custom	79-82	608-052	_____
CX500D Deluxe	79-81	608-052	_____
GL500 Silverwing	81-82	608-052	_____
GL500I Silverwing Interstate	81-82	608-052	_____
CB550/K1	74-75	_____	609-050
CB550K	76-78	_____	609-050
CB550F Super Sport	75-77	_____	609-050
CB550SC Nighthawk	1983	608-1072	609-5072
CB650SC Nighthawk	83-85	608-1072	609-5072
CX650C Custom	1983	608-094	609-094
GL650 Silverwing	1983	608-094	609-094
GL650I Silverwing Interstate	1983	608-094	609-094
CB750A Automatic	76-78	608-048	609-045
CB750C Custom	80-82	608-056	609-055
CB750F Super Sport	75-78	608-048	609-045
CB750F Super Sport	79-82	608-056	609-055
CB750K2/K3	70-73	608-0156	_____
CB750K4/K5	74-75	608-048	609-045
CB750/K	76-78	608-048	609-045
CB750K	79-82	608-056	609-055
CB750L LTD	1979	608-056	609-055

### Honda Street

Model	Year	Complete	Top End
CB750SC Nighthawk	82-83	608-056	609-055
CB900C Custom	80-82	608-057	_____
CB900F Super Sport	81-82	608-057	_____
GL1000K Goldwing	75-79	_____	609-046
GL1000L Goldwing LTD	1975	_____	609-046
CB1100F Super Sport	1983	608-097	609-097
GL1100 Goldwing	80-83	608-067	_____
GL1100A Goldwing Aspencade	82-83	608-067	_____
GL1100I Goldwing Interstate	80-83	608-067	_____
GL1200 Goldwing	1984	_____	609-5106
GL1200A Goldwing Aspencade	1984	_____	609-5106
GL1200A Goldwing Aspencade	85-87	608-1107	609-5106
GL1200I Goldwing Interstate	1984	_____	609-5106
GL1200I Goldwing Interstate	85-87	608-1107	609-5106

### Kawasaki Street

AR50A1	1982	_____	_____
KZ200A1/A2	78-79	608-624	_____
S1A/B/C-250 (2 stroke triple)	73-75	608-650	_____
KH250A5 (2 stroke triple)	1976	608-0433	_____
S2-350/A (2 stroke triple)	72-73	608-655	_____
S3/S3A-400 (2 stroke triple)	74-75	608-656	_____
KH400A3/A4/A5 (2 stroke triple)	76-78	608-656	_____
KZ400B1/B2	78-79	608-0497	_____
KZ400C1	1978	608-0497	_____
KZ400H1 LTD	1978	608-0497	_____
KZ440A1/A2/A3/A4 LTD	80-83	608-0457	_____
KZ440B1/B2	80-81	608-0457	_____
KZ440D1-D5 LTDBelt	80-83	608-0457	_____
H1/A/B/C-500 Mach III	69-72	608-0421	_____
H1D/E/F-500 (2 stroke triple)	73-75	608-0421	_____
KH500A8 (2 stroke triple)	1976	608-0421	_____
KZ550C4 LTD	1983	608-0464	_____
KZ550D1 GPz	1981	608-0455	609-0855
KZ550F1 Spectre	1983	_____	_____
KZ550F2 LTD Shaft	1984	_____	_____
KZ550H1/H2 GPz	82-83	608-640	609-640
ZX550A1/A2/A3 GPz	84-86	_____	609-643
ZX600A1/A2/A3 Ninja 600R	85-87	608-4011	609-8011
KZ650B1/B2/B2A	77-78	608-0481	609-0881
KZ650B3	1979	608-0482	609-0882
KZ650C1/C2 Custom	77-78	608-0481	609-0881
KZ650C3 Custom	1979	608-0482	609-0882
KZ650D1/D1A SR	1978	608-0481	609-0881
KZ650D2 SR	1979	608-0482	609-0882
KZ650E1 LTD	1980	608-0482	609-0882
KZ650F1	1980	608-0482	609-0882
W1-650 2-cylinder	66-69	608-4086	_____
W1SS-650 2-cylinder	68-69	608-4086	_____
W2-SS650 2-cylinder	67-70	608-4086	_____
KZ700A1	1984	608-644	_____
ZN700A1/A2 LTD Shaft	84-85	608-644	_____
H2/A/B/C-750 (2 stroke triple)	72-75	608-665	_____
KZ750E1/E2/E3	80-82	608-0488	609-0848
KZ750F1 LTD Shaft	1983	608-631	609-631
KZ750H1/H2/H3 LTD	80-82	608-0488	609-0848
KZ750H4 LTD	1983	608-631	609-631
KZ750L3	1983	608-631	609-631
KZ750N1/N2 Spectre	82-83	608-631	609-631
ZX750A1/A2/A3 GPz	83-85	608-631	609-631
ZX750E1/E2 GPz Turbo	84-85	_____	_____
Z1A/B-900	74-75	608-618	609-0824
KZ900A4/A5	76-77	608-618	609-0824
KZ900B1 LTD	1976	608-618	609-0824

## Kawasaki Street

Model	Year	Complete	Top End
KZ1000A1/A2/A2A	77-78	608-0436	609-0836
KZ1000A3/A3A/A4 MKII	79-80	608-619	609-611
KZ1000B1/B2 LTD	77-78	608-0436	609-0836
KZ1000B3/B4 LTD	79-80	608-619	609-611
KZ1000C1/C1A Police	1978	608-0436	609-0836
KZ1000C2/C3/C4 Police	79-81	608-619	609-611
KZ1000D1 Z1R	1978	608-0436	609-0836
KZ1000D3 Z1R	1980	608-619	609-611
KZ1000E1/E2 Shaft ST	79-80	————	609-611
KZ1000G1 LTD Classic	1980	608-619	609-611
KZ1000J1/J2/J3	81-83	608-620	609-0839
KZ1000K1/K2 LTD	81-82	608-620	609-0839
KZ1000M1/M2 CSR	81-82	608-620	609-0839
KZ1000P1-P21 Police	82-02	608-620	609-0839
KZ1000R1/R2 Replica	82-83	608-620	609-0839
KZ1100A1/A2/A3 Shaft	81-83	608-621	609-0847
KZ1100B1/B2 GPz	81-82	608-621	609-0847
KZ1100D1/D2 Spectre	82-83	608-621	609-0847
KZ1100L1 LTD Shaft	1983	608-621	609-0847
ZN1100B1/B2 LTD Shaft	84-85	608-642	609-0847
ZX1100A1/A2 GPz	83-84	608-642	609-0847
KZ1300A1/A2/A3/A4	79-82	608-4010	609-8010
KZ1300B2 Touring	1980	608-4010	609-8010

## Suzuki Street

GT380 J/K/L/M/A/B Sebring	72-77	————	————
GS400B/XB/C/XC	77-78	————	————
GS450ET/EX/EZ	80-82	————	————
GS450LT/LX	80-81	————	————
GS450ST/SX	80-81	————	————
GS450TX	1981	————	————
T500R/J/K/L/M Titan	71-75	608-0329	————
GT500A/B	76-77	608-0329	————
GS550B/C/EC/N/EN/ET	77-80	608-0345	————
GS550LN/LT/LX/LZ	79-82	608-0345	————
GS700EEF/ESF	1985	————	————
GS750ET/EX	80-81	————	609-0759
GS750EZ	1982	————	————
GS750ED/ESD	1983	608-3003	609-7003
GS750LT/LX	80-81	————	609-0759
GS750TZ/TD	82-83	————	————
GS750SD Katana	1983	608-3002	609-7002
GS850GN/GT/GX	79-81	608-440	————
GS850GZ/GD	82-83	————	————
GS850GLT/GLX	80-81	608-440	————
GS850GLZ/GLD	82-83	————	————
GS1000C/EC/N/EN/ET	78-80	608-0352	————
GS1000LN	1979	608-0352	————
GS1000SN/ST	79-80	608-0352	————
GS1100ET/EX	80-81	608-421	————
GS1100EZ	1982	608-0380	————
GS1100ED/ESD	1983	608-429	————
GS1100GZ/GD	82-83	608-430	————
GS1100GLZ/GLD	82-83	608-430	————
GS1100GKZ/GK2/GKD/GKE	82-84	608-430	————
GS1100LT	1980	608-421	————
GS1100SD Katana	1983	608-429	————
GS1150ES3/ESE/EF/ESF/EF2	83-85	————	609-7027

## Yamaha Street

Model	Year	Complete	Top End
YSR50T/U/W/A/B/D	87-92	608-2057	————
RD350/A/B	73-75	608-0251	609-205
RZ350L/N/NC/NCII	84-85	608-255	609-255
RD400C/D/E/F	77-79	608-0261	————
RS500LCL	1984	————	609-6052
RD500LCN	1985	————	609-6052
<b>(Canadian &amp; European application only, RS500/RD500)</b>			
SR500E/F/G/H	78-81	608-231	609-231
XT500C/D/E/F/G Dual Sport	76-81	608-231	609-231
XV500K Virago	1983	————	609-6023
XJ550H/J/K Maxim	81-83	608-253	609-253
XJ550RH/RJ/RK Seca	81-83	608-253	609-253
XT550J/K Dual Sport	82-83	608-240	————
XZ550RJ Vision	1982	608-2025	————
FJ600L/LC/N/NC	84-85	————	609-6051
FZ600S/SC/T/TC/U/UC	86-88	————	609-6051
SRX600S/SC	1986	608-254	609-254
XT600L/LC Dual Sport	1984	608-254	609-254
XT600T/TC Dual Sport	1987	608-254	609-254
YX600S/SC/T/TC/U/UC Radian	86-88	608-2063	609-6051
XJ650G/H Maxim	80-81	608-2016	609-6016
XJ650LH Midnight Maxim	1981	608-2016	609-6016
XJ650LJ/LK Seca Turbo	82-83	608-2017	609-6017
XJ650RJ Seca	1982	608-2016	609-6016
XS650B/C/D/E/F	75-79	608-0282	————
XS650G/H Special II	80-81	608-0282	————
XS6502F	1979	608-0282	————
XS650SE/SF/SG/SH Special	78-81	608-0282	————
XS650SJ/SK Heritage Special	82-83	608-251	609-251
FZ700T/TC	1987	608-2064	609-6064
FZ750N/S/SC	85-86	608-2064	609-6064
FZ750U/UC	1988	608-2064	609-6064
FZR750RT/RU	87-88	608-2064	609-6064
XJ750J/K Maxim	82-83	608-2014	————
XJ750MK Midnight Maxim	1983	608-2014	————
XJ750RH/RJ/RK Seca	81-83	608-2014	————
XV750H/J/K Virago	81-83	608-249	609-249
XV750MK Midnight Virago	1983	608-249	609-249
XV750U/UC/W/WC Virago	88-89	608-2081	609-6081
XS850G/H	80-81	608-2000	609-2000
XS850LG/LH Midnight Special	80-81	608-2000	609-2000
XS850SG/SH Special	80-81	608-2000	609-2000
XV920J/K Virago	82-83	608-248	609-248
XV920MK Midnight Virago	1983	608-248	609-248
XV920RH/RJ Virago	81-82	608-248	609-248
FZR1000U/UC	1988	608-2082	609-6082
XV1000L/LC/N/NC Virago	84-85	608-2050	609-6050
FJ1100L/LC/N/NC	84-85	608-2056	609-6056
XJ1100J Maxim	1982	608-0297	609-0697
XS1100E/F/G/H	78-81	608-250	609-250
XS1100LG/LH Midnight Special	80-81	608-250	609-250
XS1100SF/SG/SH Special	79-81	608-250	609-250
XV1100U/UC-F/FC Virago	88-94	608-2050	609-6050
FJ1200S/SC/T/TC	86-87	————	————



# Base & Head Gaskets



644-1022



645-1028

## Vesrah Base & Head Gaskets

Replacement base and head gaskets for applications listed. Sold each. *Made in Japan.*

### Honda Street

Model	Year	Base Gskt	Head Gskt
NT650 Hawk GT	88-91	_____	<b>644-1073</b>
NX650	88-89	_____	<b>644-1081</b>
VFR700F2 Interceptor	86-87	_____	<b>644-1047</b>
CB750A Automatic	76-78	<b>645-1028</b>	<b>644-1022</b>
CB750C Custom	80-82	_____	<b>644-1023</b>
CB750F Super Sport	75-78	<b>645-1028</b>	<b>644-1022</b>
CB750F Super Sport	79-82	_____	<b>644-1023</b>
CB750/K1/K2/K3/K4/K5	69-75	<b>645-1028</b>	<b>644-1022</b>
CB750K	76-78	<b>645-1028</b>	<b>644-1022</b>
CB750K	79-82	_____	<b>644-1023</b>
CB750L LTD	1979	_____	<b>644-1023</b>
CB750SC Nighthawk	82-83	_____	<b>644-1023</b>
VFR750F Interceptor	1986	_____	<b>644-1047</b>
VFR1000F Interceptor	1984	_____	<b>644-1063</b>
VFR1000R	1985	_____	<b>644-1063</b>
VF1100C	83-86	_____	<b>644-1065</b>
VF1100S	84-85	_____	<b>644-1065</b>

### Kawasaki Street

**(Requires qt 2 for applications in red)**

KZ650H1/H2/H3 CSR	81-83	<b>645-4013</b>	_____
KZ700A1	1984	<b>645-4013</b>	_____
ZN700A1/A2 LTD Shaft	84-85	<b>645-4013</b>	_____
KZ750E1/E2/E3	80-82	<b>645-4013</b>	<b>644-4015</b>
KZ750F1	1983	<b>645-4013</b>	<b>644-4015</b>
KZ750H1/H2/H3/H4 LTD	80-83	<b>645-4013</b>	<b>644-4015</b>
KZ750L3	1983	<b>645-4013</b>	<b>644-4015</b>
KZ750N1/N2 Spectre	82-83	<b>645-4013</b>	<b>644-4015</b>
KZ750R1 GPz	1982	<b>645-4013</b>	<b>644-4015</b>
ZX750A1/A2/A3 GPz	83-85	<b>645-4013</b>	<b>644-4015</b>
ZX750E1/E2 GPz Turbo	84-85	<b>645-4013</b>	_____
Z1900 (1 piece head gasket)	1973	<b>645-4022</b>	<b>609-880</b>
Z1A/B-900	74-75	<b>645-4022</b>	<b>644-4021</b>
KZ900A4/A5	76-77	<b>645-4022</b>	<b>644-4021</b>
KZ900B1 LTD	1976	<b>645-4022</b>	<b>644-4021</b>
ZL900A1/A2 Eliminator	85-86	<b>645-4041</b>	_____
ZX900A1/A2/A3 Ninja 900	84-86	<b>645-4041</b>	_____
KZ1000A1/A2/A2A	77-78	<b>645-4022</b>	<b>644-4022</b>
KZ1000A3/A3A/A4 MKII	79-80	<b>645-4022</b>	<b>644-4022</b>
KZ1000B1/B2 LTD/B3/B4 LTD	77-80	<b>645-4022</b>	<b>644-4022</b>
KZ1000C1/C1A/C2/C3/C4 Police	78-81	<b>645-4022</b>	<b>644-4022</b>
KZ1000D1 Z1R	1978	<b>645-4022</b>	<b>644-4022</b>
KZ1000D3 Z1R	1980	<b>645-4022</b>	<b>644-4022</b>
KZ1000A3/A3A/A4 MKII	79-80	<b>645-4022</b>	<b>644-4022</b>
KZ1000B1/B2 LTD/B3/B4 LTD	77-80	<b>645-4022</b>	<b>644-4022</b>
KZ1000C1/C1A/C2/C3/C4 Police	78-81	<b>645-4022</b>	<b>644-4022</b>
KZ1000D1 Z1R	1978	<b>645-4022</b>	<b>644-4022</b>
KZ1000D3 Z1R	1980	<b>645-4022</b>	<b>644-4022</b>
KZ1000E1/E2 Shaft ST	79-80	<b>645-4022</b>	<b>644-4022</b>

## Kawasaki Street

Model	Year	Base Gskt	Head Gskt
<b>(Requires qt 2 for applications in red)</b>			
KZ1000G1 LTD Classic	1980	<b>645-4022</b>	<b>644-4022</b>
KZ1000J1/J2/J3	81-83	<b>645-4016</b>	<b>644-4023</b>
KZ1000K1/K2 LTD	81-82	<b>645-4016</b>	<b>644-4023</b>
KZ1000M1/M2 CSR	81-82	<b>645-4016</b>	<b>644-4023</b>
KZ1000P1-P21 Police	82-02	<b>645-4016</b>	<b>644-4023</b>
KZ1000R1/R2 Replica	82-83	<b>645-4016</b>	<b>644-4023</b>
ZL1000A1 Eliminator	1987	<b>645-4041</b>	_____
ZX1000A1/A2 Ninja 1000R	86-87	<b>645-4041</b>	_____
ZX1000B1/B2/B3 Ninja ZX-10	88-90	<b>645-4041</b>	_____
KZ1100A1/A2/A3 Shaft	81-83	<b>645-4016</b>	<b>644-4024</b>
KZ1100B1/B2 GPz	81-82	<b>645-4016</b>	<b>644-4024</b>
KZ1100D1/D2 Spectre	82-83	<b>645-4016</b>	<b>644-4024</b>
KZ1100L1 LTD Shaft	1983	<b>645-4016</b>	<b>644-4024</b>
ZN1100B1/B2 LTD Shaft	84-85	<b>645-4016</b>	<b>644-4016</b>
ZX1100A1/A2 GPz	83-84	<b>645-4016</b>	<b>644-4016</b>

## Suzuki Street

GS-XR750G/H	86-87	_____	<b>644-3033</b>
GS-XR750J/K	88-89	_____	<b>644-3033</b>
GS1000C/EC/N	78-79	<b>645-3004</b>	<b>644-3003</b>
GS1000EN/ET	80-81	<b>645-3004</b>	<b>644-3003</b>
GS1000GT/GX	80-81	<b>645-3004</b>	<b>644-3003</b>
GS1000GLT/GLX	80-81	<b>645-3004</b>	<b>644-3003</b>
GS1000LN	1979	<b>645-3004</b>	<b>644-3003</b>
GS1000SN/ST	79-80	<b>645-3004</b>	<b>644-3003</b>
GS1100ED/ESD	1983	<b>645-3005</b>	<b>644-3004</b>
GS1100SD Katana	1983	<b>645-3005</b>	<b>644-3004</b>
GS1100GKZ/GKD/	82-83	_____	<b>644-3005</b>
GS1100GZ/GLZ/GD/GLD	82-83	_____	<b>644-3005</b>
GSX1100FJ-FN Katana	88-92	_____	_____
GSX-R1100G/H/J	86-88	_____	_____

## Yamaha Street

DT125		<b>645-2046</b>	_____
RD125LC (non USA model)	82-84	<b>645-2048</b>	_____
RD350LC (non USA model)	1985	<b>645-2005</b>	<b>644-2005</b>
RZ350L/N/NC/NCII	83-84	<b>645-2005</b>	<b>644-2005</b>
RD400C/D/E/F	76-79	<b>645-2004</b>	<b>644-2004</b>
SR500E/F/G/H	78-81	<b>645-2035</b>	<b>644-2035</b>
XT500C/D/E/F/G/H	76-82	<b>645-2035</b>	<b>644-2035</b>
XS650B/C/D/E/F/2F	76-79	<b>645-2036</b>	<b>644-2036</b>
XS650SE/SF/SG/SH Special	78-81	<b>645-2036</b>	<b>644-2036</b>
XS650SJ/SK Heritage Special	82-83	<b>645-2036</b>	<b>644-2036</b>
FJ1100L/LC/N/NC	84-85	<b>645-2038</b>	_____
XS1100J Maxim	1982	_____	_____
XS1100E/F/G/H	78-81	_____	<b>644-2026</b>
XS1100LG/LH Midnight Special	80-81	_____	<b>644-2026</b>
XS1100SF/SG/SH Special	79-81	_____	<b>644-2026</b>







609-880

## Z1-900 One Piece Head Gasket

Replacement head gasket for 1973 Kawasaki Z1-900. Sold each. *Made in Japan.*

### Kawasaki

OEM Ref. 11004-052, 11004-1269

Order No. **609-880**

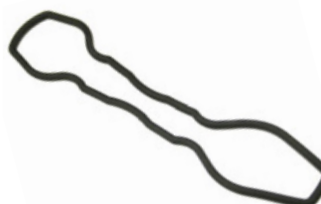

650-001



650-005

## Cylinder Head O-Rings

Kawasaki models. Sold each. *Made in Japan.*

### Kawasaki

OEM Ref. 92055-062

Order No. **650-001**

Model	Year
Z1/A/B-900	73-75
KZ900A4/A5	76-77
KZ900B1 LTD	1976
KZ1000A1/A2	77-78
KZ1000A3/A3A/A4 MKII	79-80
KZ1000B1/B2/B3/B4 LTD	77-80
KZ1000C1/C1A/C2/C3/C4 Police	78-81
KZ1000D1 Z1R	1978
KZ1000D3 Z1R	1980
KZ1000E1/E2 Shaft ST	79-80
KZ1000G1 LTD Classic	1980

OEM Ref. 11009-1208

Order No. **650-005**

Model	Year
KZ1000J1/J2/J3	81-83
KZ1000K1/K2 LTD	81-82
KZ1000M1/M2 CSR	81-82
KZ1000P1-P21 Police	82-02
KZ1000P24 Police	2005
KZ1000R1/R2 Replica	82-83
KZ1100A1/A2/A3 Shaft	81-83
KZ1100B1/B2 GPz	81-82
KZ1100D1/D2 Spectre	82-83
KZ1100L1 LTD	1983
ZN1100B1/B2 LTD Shaft	84-85
ZX1100A1/A2 GPz	83-84



## H2-750 Cylinder Head Bolt Kit

Kit includes 12 Zinc Plated Bolts, 12 Washers, 12 Spring Washers. For Kawasaki H2-750 72-75.

Order No. **901-315**



## H2-750 Stub Nut Kit

Kit includes 12 lock nuts (10mm), 12 lock washers (10mm), 15 nuts (6mm), and 15 lock washers (6mm) all Zinc plated. For Kawasaki H2-750 72-75.

Order No. **901-330**

# Valve Cover Gaskets & Cam End Rubber Plugs



619-009



619-018

## Vesrah Valve Cover Gaskets & Cam End Plugs

Sold each. *Made in Japan.*

### Honda Street

Model	Year	Vlv.Cover Gasket	Cam End Rubber Plug
CB400A Automatic	1978	619-007	_____
CB400T Hawk	80-81	619-007	_____
CB400T1 Hawk	78-79	619-007	_____
CB400TII Hawk	78-79	619-007	_____
CM400A Automatic	79-81	619-007	_____
CM400C Custom	1981	619-007	_____
CM400E	80-81	619-007	_____
CM400T	79-81	619-007	_____
CB450D Super Sport 450	1967	619-035	_____
CB450K0	65-68	619-035	_____
CB450K1-K7 Super Sport 450	68-74	619-035	_____
CB450SC Nighthawk	82-86	619-007	_____
CB450T Hawk	1982	619-007	_____
CL450/K1-K6 Scrambler 450	67-74	619-035	_____
CM450A Automatic	82-83	619-007	_____
CM450C Custom	1982	619-007	_____
CM450E	82-83	619-007	_____
CB500K0/K1/K2 (4cyl.)	71-73	619-006	_____
CB500T (twin)	75-76	619-035	_____
CX500	78-79	619-004	_____
CX500C Custom	79-82	619-004	_____
CX500D Deluxe	79-81	619-004	_____
FT500 Ascot	82-83	619-005	_____
GL500 Silverwing	81-82	619-004	_____
GL500I Interstate	81-82	619-004	_____
VF500C V30 Magna	84-85	619-016	_____
VF500F Interceptor	84-86	619-016	_____
VT500C Shadow	83-86	619-015	_____
VT500FT Ascot	83-84	619-015	_____
XL500S Dual Sport	79-81	619-005	_____
CB550F Super Sport	75-77	619-006	_____
CB550/K1	74-75	619-006	_____
CB550K	76-78	619-006	_____
CX650C Custom	1983	619-004	_____
CX650T Turbo	1983	619-004	_____
GL650 Silverwing	1983	619-004	_____
GL650I Silverwing Interstate	1983	619-004	_____
CB700SC Nighthawk S	84-86	619-018	_____
VF700C Magna	84-85	_____	_____
VF700F Interceptor	84-85	_____	_____
VF700S Sabre	84-85	_____	_____
VFR700F Interceptor	1986	619-041	_____
VFR700F2 Interceptor	86-87	619-041	_____
CB750A Automatic	76-78	619-003	_____
CB750C Custom	80-82	_____	_____
CB750F Super Sport	75-78	619-003	_____
CB750F Super Sport	79-82	_____	_____
CB750K/K1/K2/K3/K4/K5	69-75	619-003	_____
CB750K	76-78	619-003	_____
CB750K	79-82	_____	_____
CB750L LTD	1979	_____	_____
CB750SC Nighthawk	82-83	_____	_____
VF750C V45 Magna	82-83	_____	_____

### Honda Street

Model	Year	V.Cover Gasket	Cam End Rubber Plug
VF750C V45 Magna	1988	619-019	_____
VF750F V45 Interceptor	83-84	_____	_____
VF750S V45 Sabre	82-83	_____	_____
CB900C Custom	80-82	_____	_____
CB900F Super Sport	81-82	_____	_____
CB1000C Custom	1983	_____	_____
CBR1000F Hurricane	87-88	619-043	_____
GL1000 Goldwing	75-79	619-001	_____
GL1000L Goldwing LTD	1976	619-001	_____
VF1000R	85-86	619-019	_____
CB1100F Super Sport	1983	_____	_____
GL1100 Goldwing	80-83	619-001	_____
GL1100A Golden Aspencade	82-83	619-001	_____
GL1100I Goldwing Interstate	80-83	619-001	_____
VF1100C V65 Magna	83-86	619-021	_____
VF1100S V65 Sabre	84-85	619-021	_____
GL1200 Goldwing	1984	619-038	_____
GL1200A Goldwing Aspencade	84-87	619-038	_____
GL1200I Goldwing Interstate	84-87	619-038	_____
GL1200L Goldwing LTD	1985	619-038	_____
GL1200SEi Goldwing SEi	1986	619-038	_____
GL1500 Goldwing	88-90	619-048	_____

### Kawasaki Street

KZ550A1/A2/A3	80-82	619-604	620-991
KZ550A4	1983	619-609	620-991
KZ550C1/C2/C3/C4 LTD	80-83	619-604	620-991
KZ550D1 GPz	1981	619-604	620-991
KZ550F1 Spectre	1983	619-609	620-991
KZ550F2 LTD	1983	619-609	620-991
KZ550H1/H2 GPz	82-83	619-609	620-991
KZ550M1 LTD	1983	619-609	620-991
ZX550A1/A2 GPz	84-85	619-609	620-991
KL600A1/B1/B2 KLR600	84-86	619-617	_____
ZL600A1/A2 Eliminator	85-86	619-614	_____
ZL600B2/B3 Eliminator 600	96-97	619-614	_____
ZX600A1/A2/A3 Ninja 600R	85-87	619-614	_____
ZX600B1 Ninja 600RX	1987	619-614	_____
ZX600C1-C10 Ninja 600R	88-97	619-614	_____
KL650A1-A19 KLR650	87-05	619-617	_____
KZ650B1/B2	77-78	619-613	620-991
KZ650B3	1979	619-605	620-991
KZ650C1/C2 Custom	77-78	619-613	620-991
KZ650C3 Custom	1979	619-605	620-991
KZ650D1 SR	1978	619-613	620-991
KZ650D2 SR	1979	619-605	620-991
KZ650E1 LTD	1980	619-605	620-991
KZ650F1	1980	619-605	620-991
KZ650H1/H2 CSR	81-82	619-608	620-991
KZ650H3 CSR	1983	619-610	620-991
KZ700A1	1984	619-610	620-991
ZN700A1/A2 LTD	84-85	619-610	620-991
KZ750B1/B2/B3/B4 (2-cyl.)	76-79	619-602	_____
KZ750E1/E2/E3	80-82	619-608	620-991
KZ750F1 LTD Shaft	1983	619-610	620-991
KZ750G1 LTD (2-cyl.)	1980	619-602	_____

# Valve Cover Gaskets & Cam End Rubber Plugs

VINTAGE  
INTAKE  
ENGINE  
SUSPENSION  
CONTROL  
ELECTRICAL  
CHEMICAL  
TOOLS  
WATERCRAFT

## Kawasaki Street

Model	Year	V.Cover Gasket	Cam End Rubber Plug
KZ750H1/H2/H3 LTD	80-82	619-608	620-991
KZ750H4 LTD	1983	619-610	620-991
KZ750L3	1983	619-610	620-991
KZ750N1/N2 Spectre	82-83	619-610	620-991
KZ750R1 GPz	1982	619-610	620-991
ZX750A1/A2/A3 GPz	83-85	619-610	620-991
ZX750E1/E2 GPz Turbo	84-85	619-610	620-991
Z1/A/B-900	73-75	619-601	620-990
KZ900A4/A5	76-77	619-601	620-990
KZ900B1 LTD	1976	619-601	620-990
KZ1000A1/A2	77-78	619-601	620-990
KZ1000A3/A3A/A4 MKII	79-80	619-603	620-990
KZ1000B1/B2 LTD	77-78	619-601	620-990
KZ1000B3/B4 LTD	79-80	619-603	620-990
KZ1000C1/C1A Police	1978	619-601	620-990
KZ1000C2-C4 Police	79-81	619-603	620-990
KZ1000D1 Z1R	1978	619-601	620-990
KZ1000D3 Z1R	1980	619-603	620-990
KZ1000E1/E2 Shaft ST	79-80	619-603	620-990
KZ1000G1 LTD Classic	1980	619-603	620-990
KZ1000J1/J2/J3	81-83	619-606	620-992
KZ1000K1/K2 LTD	81-82	619-606	620-992
KZ1000M1/M2 CSR	81-82	619-606	620-992
KZ1000P1-P21 Police	82-02	619-606	620-992
KZ1000R1/R2 Replica	82-83	619-606	620-993
ZX1000B1/B2/B3 Ninja ZX-10	88-90	619-619	————
KZ1100A1/A2/A3 Shaft	81-83	619-606	620-992
KZ1100B1/B2 GPz	81-82	619-606	620-993
KZ1100D1/D2 Spectre	82-83	619-606	620-992
KZ1100L1 LTD Shaft	1983	619-606	620-992
ZN1100B1/B2 LTD	84-85	619-606	620-992
ZX1100A1/A2 GPz	83-84	619-606	620-993
ZG1200A Voyager XII	1986	619-622	————
ZG1200B Voyager XII	87-03	619-622	————
KZ1300A1-A4	79-82	619-607	————
KZ1300B2 Touring	1980	619-607	————
ZN1300A1-A6 Voyager	83-87	619-607	————

## Suzuki Street

GS250TT/TX	80-81	————	620-981
GS300LZ/LD	82-83	————	620-981
GS300LF	1985	————	620-981
GS400B/XB/C/XC	77-78	619-301	620-981
GS425N/EN/LN	1979	619-301	620-981
GS450ET/EX/EZ/ED	80-83	————	620-981
GS450GAZ/GAD Automatic	82-83	————	620-981
GS450GAF Automatic	1985	————	620-981
GS450LT/LX/LZ/LD	80-83	————	620-981
GS450LF/LG/LH/LJ	85-88	————	620-981
GS450ST/SX	80-81	————	620-981
GS450TX/TZ/TXZ/TXD	81-83	————	620-981
GS550B/C/EC/N/EN/ET	77-80	619-304	620-981
GS550LN/LT/LX/LZ	79-82	619-304	620-981
GS550MZ	1982	————	620-981
GS550TX	1981	619-304	620-981
GSX600FJ-FK5 Katana	88-05	619-328	————
GR650D/XD Tempter	1983	619-327	————
GS650EX/EZ	81-82	————	620-981
GR650D/XD Tempter	1983	619-327	————
GS650EX/EZ	81-82	————	620-981
GS650GX	1981	————	620-981
GS650GZ/GD	82-83	————	620-981
GS650GLX/GLZ	81-82	————	620-981
GS650GLD	1983	————	620-981
GS650MD Katana	1983	————	620-981
XN85 Turbo	1983	————	620-981

## Suzuki Street

Model	Year	V.Cover Gasket	Cam End Rubber Plug
GS700EF/ESF	1985	619-326	————
GS750B/C/EC/N/EN	77-79	619-302	620-981
GS750ET/EX	80-81	619-305	620-981
GS750EZ	1982	619-307	620-981
GS750ED/ESD	1983	619-326	————
GS750LN	1979	619-302	620-981
GS750LT/LX	80-81	619-305	620-981
GS750SD Katana	1983	619-320	620-981
GS750TZ/TD	82-83	619-307	620-981
GSX-R750RG	1986	619-328	————
GSX-R750G/H	86-87	619-328	————
GSX-R750J/K	88-89	619-329	————
GS850GN/GT/GX	79-81	619-302	620-981
GS850GZ/GD	82-83	————	620-981
GS850GLT/GLX	80-81	619-302	620-981
GS850GLZ/GLD	82-83	————	620-981
GS1000C/EC/N/EN/ET	78-80	619-303	620-981
GS1000GT/GLT/GX/GLX	80-81	619-303	620-981
GS1000LN	1979	619-303	620-981
GS1000SN/ST	79-80	619-303	620-981
GS1000SZ Katana	1982	619-305	620-981
GS1100ET/EX	80-81	619-305	620-981
GS1100EZ	1982	619-307	620-981
GS1100ED/ESD	82-83	619-320	620-981
GS1100GZ/GLZ/GD/GLD	82-83	619-306	620-981
GS1100GK/GK2/GKD/GKE	82-84	619-306	620-981
GS1100LT	1980	619-305	620-981
GSX1100FJ-FP Katana	88-93	619-329	————
GSX-R1100G/H/J	86-88	619-329	————

## Yamaha Street

SRX250T/TC	1987	619-209	————
FZR400U/SUC-A/SAC	88-90	619-215	————
XS400J/K Maxim	82-83	619-205	620-998
XS400RJ/RK Seca	82-83	619-205	620-998
XJ550H/J/K Maxim	81-83	619-206	————
XJ550RH/RJ/RK Seca	81-83	619-206	————
FJ600/LC/N/NC	84-85	619-206	————
FZ600S/SC/T/TC/U/UC	86-88	619-206	————
YX600S/SC-A/AC Radian	86-90	619-206	————
XJ650G/H Maxim	80-81	619-202	620-998
XJ650J/K Maxim	82-83	619-213	————
XJ650LH Midnight Maxim	1981	619-202	620-998
XJ650LH Midnight Maxim	1981	619-202	620-998
XJ650LJ/LK Seca Turbo	82-83	————	620-998
XJ650RJ Seca	1982	619-202	620-998
FZ700T/TC	1987	619-211	————
XJ700N/NC/S/SC Maxim	85-86	619-213	————
XJ700X Maxim X	85-86	619-211	————
FZ750N/S/SC	85-86	619-211	————
FZ750U/UC	1988	619-211	————
FZR750RT/RU	87-88	619-211	————
XJ750J/K/MK Maxim & Midnight	82-83	619-213	————
XJ750RH/RJ/RK Seca	82-83	619-213	————
XS750D/2D/E/F	77-79	619-201	620-998
XS750SE/SF Special	78-79	619-201	620-998
XS850G/H	80-81	619-201	620-998
XS850LG/LH Midnight Special	80-81	619-201	620-998
XS850SG/SH Special	80-81	619-201	620-998
FZR1000T/TC/U/UC	87-88	619-211	————
FJ1100L/LC/N/NC	84-85	619-210	————
XJ1100J Maxim	1982	619-203	620-998
XS1100E/F/G/H	78-81	619-203	620-998
XS1100LG/LH Midnight Special	80-81	619-203	620-998
XS1100SF/SG/SH Special	79-81	619-203	620-998
FJ1200S/SC/T/TC /W/WC/A/AC	86-90	619-210	————



# Camshaft End Rubber Plugs



620-990



620-992



620-981

## Camshaft End Rubber Plugs

Replacement camshaft end rubber plugs. Sold in 4 pc. sets. *Made in Japan.*

### Kawasaki

OEM Ref.	Order No.	Year
92066-017	<b>620-990</b>	
Z1/A/B-900		73-75
KZ900A4/A5		76-77
KZ900B1 LTD		1976
KZ1000A1/A2		77-78
KZ1000A3/A4 MKII		79-80
KZ1000B1/B2/B3/B4 LTD		77-78
KZ1000C1/C1A/C2/C3/C4		78-81
KZ1000D1 Z1R		1978
KZ1000D3 Z1R		1980
KZ1000E1/E2 Shaft ST		79-80
KZ1000G1 LTD Classic		1980

Note: See page 31 for Billet Cam End Plugs.

OEM Ref.	Order No.	Year
92066-1111	<b>620-991</b>	
KZ550A1/A2/A3/A4		80-83
KZ550C1/C2/C3/C4 LTD		80-83
KZ550D1 GPz		1981
KZ550F1 Spectre		1983
KZ550F2 LTD		1983
KZ550H1/H2 GPz		82-83
KZ550M1 LTD		1983
ZX550A1/A2 GPz		84-85
KZ650B1/B2/B2A/B3		77-79
KZ650C1/C2/C3 Custom		77-78
KZ650D1/D2 SR		78-79
KZ650E1/F1		1980
KZ650H1/H2/H3 CSR		81-83
KZ700A1		1984
ZN700A1/A2 LTD		84-85
KZ750E1/E2/E3		80-82
KZ750F1 LTD Shaft		1983
KZ750H1/H2/H3/H4 LTD		80-83
KZ750L3		1983
KZ750N1/N2 Spectre		82-83
KZ750R1 GPz		1982
ZX750A1/A2/A3 GPz		83-85
ZX750E1/E2 GPz Turbo		84-85



620-991

### Kawasaki

OEM Ref.	Order No.	Year
92066-1106	<b>620-992</b>	
Use with cylinder head not black or as an option for models listed under 620-993		
KZ1000J1/J2/J3		81-83
KZ1000K1/K2 LTD		81-82
KZ1000M1/M2 CSR		81-82
KZ1000P1-P19 Police		82-00
KZ1100A1/A2/A3 Shaft		81-83
KZ1100D1/D2 Spectre		82-83
KZ1100L1 LTD Shaft		1983
ZN1100B1/B2 LTD		84-85

OEM Ref.	Order No.	Year
92066-1104	<b>620-993</b>	
Use with black cylinder head or as an option for models listed		
KZ1000J1/J2/J3		81-83
KZ1000R1/R2 Replica		82-83
KZ1100B1/B2 GPz		81-82
ZX1100A1/A2 GPz		83-84

### Suzuki

OEM Ref.	Order No.	Year
09241-23002	<b>620-981</b>	
GS250TT/TX		80-81
GS300LZ/LD		82-83
GS300LF		1985
GS400B/XB/C/XC		77-78
GS425N/EN/LN		1979
GS450ET/EX/EZ/ED		80-83
GS450GA Automatic		82-83
GS450GAF Automatic		1985
GS450LT/LX/LZ/LD		80-83
GS450LF/LG/LH/LJ		85-88
GS450ST/SX		80-81
GS450TX/TZ/TXZ/TXD		81-83
GS550B/C/EC/N/EN		77-79
GS550ET		1980
GS550LN/LT/LX/LZ		79-82
GS550MZ		1982
GS550TX		1981
GS650EX/EZ		81-82
GS650GX/GZ/GD		81-83
GS650GLX/GLZ/GLD		81-83
GS650MD Katana		1983
GS750B/C/EC/N/EN		77-79
GS750ET/EX/EZ		80-82
GS750LN/LT/LX		79-81
GS750SD Katana		1983
GS750TZ/TD		82-83
XN85D Turbo		1983

### Suzuki

OEM Ref.	Order No.	Year
09241-23002	<b>620-981</b>	
GS850GN/GT/GX/GZ/GD		79-83
GS850GLT/GLX/GLZ/GLD		80-83
GS1000C/EC/N		78-79
GS1000EN/ET		79-80
GS1000GT/GLT/GX/GLX		80-81
GS1000LN		1979
GS1000SN/ST		79-80
GS1000SZ Katana		1982
GS1100ET/EX		80-81
GS1100EZ/ED/ESD		82-83
GS1100GZ/GLZ/GD/GLD		82-83
GS1100GKZ/GK2/GKD/GKE		82-84
GS1100LT		1980
GS1100SD Katana		1983



620-998

### Yamaha

OEM Ref.	Order No.	Year
1J7-11138-00-00	<b>620-998</b>	
XS400J/K Maxim		82-83
XS400R/JR/K Seca		82-83
XJ650G/H Maxim		80-81
XJ650LH Midnight		1981
XJ650LJ/LK Seca Turbo		82-83
XJ650RJ Seca		1982
XS750D/E/F		77-79
XS750SE/SF Special		78-79
XS850G/H		80-81
XS850LG/LH Special		80-81
XS850SG/SH Special		80-81
XJ1100J Maxim		1982
XS1100E/F/G/H		78-81
XS1100LG/LH		80-81
XS1100SF/SG/SH		79-81



## Rubber O-Ring Camshaft Holder

Honda applications. Sold each. *Made in Japan.*

### Honda

OEM Reference 91311-425-000	Order No. 620-700
Model	Year
CB750C Custom	80-82
CB750F Super Sport	79-82
CB750K	79-82
CB750L LTD	1979
CB750SC Nighthawk	82-83
CB900C Custom	80-82
CB900F Super Sport	81-82
CB1000C Custom	1983
CB1100F Super Sport	1983



## Sealing Rubber

Honda applications. Sold pk/6. *Made in Japan.*

### Honda

OEM Reference 91318-300-013	Order No. 620-710
Model	Year
CB500K0/K1/K2	71-73
CB550F Super Sport	75-77
CB550K0/K1	74-75
CB550K	76-78
CB650	79-82
CB650C Custom	80-81
CB650SC Nighthawk 650	1982
CB750A Automatic	76-78
CB750F Super Sport	75-78
CB750K0/K1/K2/K3/K4/K5	69-75
CB750K	76-78



## Cam Cover End Plugs **NEW**

Billet aluminum machined cam cover plugs with satin finish. Will not blow out or suck as the stock rubber plugs. Fits Kawasaki Z1/KZ900 and KZ1000 models shown. Sold in set of 4.

Order No: **620-9990**

### Kawasaki

Model	Year
Z1/Z1A/Z1B-900	73-75
KZ900A4/A5	76-77
KZ900B1 LTD	1976
KZ1000A1/A2	77-78
KZ1000A3/A3A/A4 MKII	79-80
KZ1000B1/B2/B3/B4 LTD	77-80
KZ1000C1/C1A/C2/C3/C4 Police	78-81
KZ1000D1 Z1R	1978
KZ1000D3 Z1R	1980
KZ1000E1/E2 Shaft St	79-80
KZ1000G1 LTD Classic	1980



## Motion Pro Tappet Tool Set

Set contains three socket wrenches in 8mm, 9mm, 10mm and three adjusters, screw type, 3mm square and 4mm square. Fits nearly all models of Honda, Suzuki, and Yamaha Motorcycles and ATV's with screw-type adjusters.

Order No. **950-440**



621-904

621-902

621-903



620-985



621-900

## Valve (Head) Cover Bolt Seals

Replacement bolt seal for valve cover bolts. Sold in 4 pc., 6 pc. and 10 pc. sets. **See Page 304-307 for applications. Made in Japan.**

# Valve Shims



## 13mm Valve Adjustment Shim Kits

Sold as dealer kit and in individual sizes. Individual sizes sold each. See model application list on next column.

### Kawasaki 13mm Diameter

13mm Diameter Dealer Shim Kit 2.30mm - 3.10mm

**Order No. 035-025**

Includes storage box and qt 2 each size of the following:  
2.30, 2.40, 2.50, 2.55, 2.60, 2.65, 2.70, 2.75, 2.80, 2.85, 2.90, 2.95, 3.00, 3.10

Valve Shim Storage Box

**Order No. 008-001**

## 13mm Valve Adjustment Shims

Sizes available from 2.30mm - 3.10mm thickness. Sold each.

Size	Order No.	Size	Order No.
2.30mm	<b>035-619</b>	2.75mm	<b>035-628</b>
2.40mm	<b>035-621</b>	2.80mm	<b>035-629</b>
2.50mm	<b>035-623</b>	2.85mm	<b>035-630</b>
2.55mm	<b>035-624</b>	2.90mm	<b>035-631</b>
2.60mm	<b>035-625</b>	2.95mm	<b>035-632</b>
2.65mm	<b>035-626</b>	3.00mm	<b>035-633</b>
2.70mm	<b>035-627</b>	3.10mm	<b>035-635</b>

## Kawasaki Street

Model	Year
KZ550A1/A2/A3	80-82
KZ550A4	1983
KZ550C1-C4 LTD	80-83
KZ550D1 GPz	1981
KZ550F1/F2 Spectre & LTD	83-84
KZ550H1/J2 GPz	82-83
1983KZ550M LTD	1983
ZR550B1/B2/B3/B4 Zephyr	90-93
ZX550A1/A2/A3 GPz	84-86
KZ650B1/B2/B2A	77-78
KZ650B3	1979
KZ650C1/C2 Custom	77-78
KZ650C3 Custom	1979
KZ650D1/D1A SR	1978
KZ650D2 SR	1979
KZ650E1 LTD	1980
KZ650F1	1980
KZ650H1/H2 CSR	81-82
KZ650H3	1983
KZ700A1	1984
ZN700A1/A2 LTD	84-85
KZ750E1/E2/E3	80-82
KZ750F1 LTD	1983
KZ750H1/H2/H3 LTD	80-82
KZ750H4	1983
KZ750L3	1983
KZ750N1/N2 Spectre	82-83
KZ750R1 GPz	1982
ZR750C1/C2/C3 Zephyr	91-93
ZR750F2 ZR-7	2000
ZR750H1/H2/H3 ZR-7S	01-03
ZX750A1/A2/A3 GPz	83-85
ZX750E1/E2 GPz Turbo	84-85
ZR1100A1/A2/A3/A4	92-95
ZR1100C/3C4 ZRX1100	99-00
ZX1100A1/A2 GPz	83-84





## 25mm Valve Adjustment Shim Kits

Sold as dealer kit and in individual sizes. Individual sizes sold each.

See model application list on next column.

### Honda/Triumph/Yamaha 25mm Diameter

25mm Diameter Dealer Shim Kit 2.30mm - 2.70mm

Order No. **035-010**

Includes storage box and qt 2 each size of the following:

2.30, 2.35, 2.40, 2.45, 2.50, 2.55, 2.60, 2.65, 2.70

25mm Diameter Dealer Shim Kit 2.75mm - 3.10mm

Order No. **035-011**

Includes storage box and qt 2 each size of the following:

2.75, 2.280, 2.85, 2.90, 2.95, 3.00, 3.05, 3.10

Valve Shim Storage Box

Order No. **008-001**

## 25mm Valve Adjustment Shims

Sizes available from 2.30mm - 3.20mm thickness. Sold each.

Size	Order No.	Size	Order No.
2.30mm	<b>035-319</b>	2.75mm	<b>035-328</b>
2.35mm	<b>035-320</b>	2.80mm	<b>035-329</b>
2.40mm	<b>035-321</b>	2.85mm	<b>035-330</b>
2.45mm	<b>035-322</b>	2.90mm	<b>035-331</b>
2.50mm	<b>035-323</b>	2.95mm	<b>035-332</b>
2.55mm	<b>035-324</b>	3.00mm	<b>035-333</b>
2.60mm	<b>035-325</b>	3.05mm	<b>035-334</b>
2.65mm	<b>035-326</b>	3.10mm	<b>035-335</b>
2.70mm	<b>035-327</b>	3.20mm	<b>035-337</b>

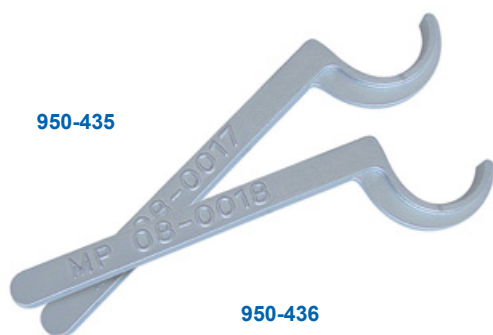

## Motion Pro Valve Shim Tools

Manufactured from hardened alloy steel. Compresses valve shim bucket for removal of valve adjustment shim.

Valve Shim Tool for Honda DOHC

Order No. **950-436**

CB750C/F/K/L/SC 80-83, CB900C/F 80-82

CB1000C 1983, CB1100F 1983, CBX1047cc 79-82

Use on Honda applications listed on next column

Valve Shim Tool for Yamaha XJ600 only

Order No. **950-435**

XJ600 Seca II (92-98)

Use with XJ600 application only

## Honda Street

Model	Year
CB750C Custom	80-82
CB750F Super Sport	79-82
CB750K	79-82
CB750L LTD	1979
CB750SC Nighthawk	82-83
CB900C Custom	80-82
CB900F Super Sport	81-82
CB1000C Custom	1983
CB1100F Super Sport	1983
CBX1047cc	79-82

## Triumph

All watercooled three & four cylinder models

## Yamaha Street

SRX250T/TC	1987
XJ600SD/SDC-SK/SKC Seca II	92-98
XVZ12TK/TDK Venture & Venture Royale	1983
XVZ12DL/DKC2/DN Venture Royale	84-85
XVZ13DS/DT Venture Royale	86-87
XVZ13DSC/DTC Venture Royale	86-87
XVZ12T/TC/U/UC Venture	87-88
XVZ13DU/DUC/DW/DWC Venture Royale	88-89
XVZ13DA/DAC/DB/DBC Venture Royale	90-91
XVZ13DD/DDC/DE/DEC Venture Royale	92-93
VMX12N/NC/S/SC V-Max	85-86
VMX12UUC/WWC/AAC/BBC/DDC/EEC V-Max	88-93
VMX12F/FC/GC/H/C/J/JC/K/KC/L/LC V-Max	94-99
VMX12M/MC/NNC/P/PC/RS/S/S1C/T/TC/VVC V-Max	00-06
FJ1100L/LC/N/NC	84-85
FJ1200S/SC/T/TC	86-87
FJ1200W/WC/A/AC/B/BC/D/DC	89-92
FJ1200AD/ADC/AE/AEC (ABS)	92-93
XVZ1300AH/AHC/AJ/AJC/AK/AKC Royal Star	96-98
XVZ1300AL/ALC/AM/AMC Royal Star Boulevard	99-00
XVZ1300AN/ANC Royal Star Boulevard	2001
XVZ1300ATH/ATHC/ATJ/ATJC Royal Star Tour Classic	96-97
XVZ1300ATK/ATKC/ATL/ATLC Royal Star Tour Classic	98-99
XVZ1300ATM/ATMC Royal Star Tour Classic	2000
XVZ1300LTL/TJCLTKLTKC Royal Star Tour Deluxe	97-98
XVZ1300LTL/LCLTMLTMC Royal Star Tour Deluxe	99-00
XVZ1300LTN/LTNC Royal Star Tour Deluxe	2001
XVZ1300CTT/CTC Royal Star Tour Deluxe	2005
XVZ1300TFSMC Royal Star Venture MM	2000
XVZ1300TFL/TFLC/TFM/TFMC Royal Star Venture	99-00
XVZ1300TFN/TFNC/TFP/TFPC Royal Star Venture	01-02
XVZ1300TFR/TFRC/TFS/TFSC Royal Star Venture	03-04
XVZ1300TFT/TFTC Royal Star Venture	2005
XVZ1300TFSP/TFSPC Royal Star Midnight Venture	2002
XVZ1300TFSR/TFSRC Royal Star Midnight Venture	2003
XVZ1300TFMS/TFMSC Royal Star Midnight Venture	2004
XVZ1300TFMT/TFMTC Royal Star Midnight Venture	2005

## Yamaha Dual Sport & Offroad

XT250L/LC Dual Sport	1984
TT350S/T Offroad	86-87
XT350N/NC-M/MC Dual Sport	85-00

# Valve Shims



## 29mm Valve Adjustment Shim Kits

Sold as dealer kit and in individual sizes. Individual sizes sold each.  
See model application list on next column.

### Kawasaki/Yamaha 29mm Diameter

Dealer Shim Kit 2.00mm - 2.50mm (total 22 shims)

**Order No. 035-015**

Includes storage box and qt 2 each size of the following:

2.00, 2.05, 2.10, 2.15, 2.20, 2.25, 2.30, 2.35, 2.40, 2.45, 2.50

Dealer Shim Kit 2.55mm - 3.10mm (total 24 shims)

**Order No. 035-016**

Includes storage box and qt 2 each size of the following:

2.55, 2.60, 2.65, 2.70, 2.75, 2.80, 2.85, 2.90, 2.95, 3.00, 3.05, 3.10

Valve Shim Storage Box

**Order No. 008-001**

## 29mm Valve Adjustment Shims

Sold each. Sizes available from 2.00mm - 3.10mm thickness.

Size	Order No.	Size	Order No.
2.00 mm	<b>035-413</b>	2.55mm	<b>035-424</b>
2.05mm	<b>035-414</b>	2.60mm	<b>035-425</b>
2.10mm	<b>035-415</b>	2.65mm	<b>035-426</b>
2.15mm	<b>035-416</b>	2.70mm	<b>035-427</b>
2.20mm	<b>035-417</b>	2.75mm	<b>035-428</b>
2.25mm	<b>035-418</b>	2.80mm	<b>035-429</b>
2.30mm	<b>035-419</b>	2.85mm	<b>035-430</b>
2.35mm	<b>035-420</b>	2.90mm	<b>035-431</b>
2.40mm	<b>035-421</b>	2.95mm	<b>035-432</b>
2.45mm	<b>035-422</b>	3.00mm	<b>035-433</b>
2.50mm	<b>035-423</b>	3.05mm	<b>035-434</b>
		3.10mm	<b>035-435</b>



**950-437**



**950-438**

## Motion Pro Valve Shim Tools

Manufactured from hardened alloy steel. Compresses valve shim bucket for removal of valve adjustment shim.

Valve Shim Tool for Kawasaki

**Order No. 950-437**

Z1/A/B-900/KZ900/KZ1000/KZ1100/KZ1300/ZN1300

Use on Kawasaki applications listed on next column

Valve Shim Tool for Yamaha

**Order No. 950-438**

XJ550/XJ650/XJ750/XS750/XS850/XS1100

Use on all Yamaha applications listed on next column

## Kawasaki Street

Model	Year
Z1/A/B-900	73-75
KZ900A4/A5	76-77
KZ900B1 LTD	1976
KZ1000A1/A2	77-78
KZ1000A3/A3A/A4 MKII	79-80
KZ1000B1/B2/B3/B4 LTD	77-80
KZ1000C1/C1A/C2/C3/C4 Police	78-81
KZ1000D1 Z1R	1978
KZ1000D3 Z1R	1980
KZ1000E1/E2 Shaft ST	79-80
KZ1000G1 LTD Classic	1980
KZ1000J1/J2/J3	81-83
KZ1000K1/K2 LTD	81-82
KZ1000M1/M2 CSR	81-82
KZ1000P1-P21 Police	82-02
KZ1000P24 Police	2005
KZ1000R1/R2 Replica	82-83
KZ1100A1/A2/A3 Shaft	81-83
KZ1100B1/B2 GPz	81-82
KZ1100D1/D2 Spectre	82-83
KZ1100L1 LTD	1983
ZN1100B1/B2 LTD	84-85
KZ1300A1/A2/A3/A4	79-82
KZ1300B2 Touring	1980
ZN1300A1-A6 Voyager	83-87

## Kawasaki Dual Sport & Offroad

KL600A1/B1/B2 KLR600	84-86
KL650A1-A19 KLR650	87-05
KL650A6F/A7F KLR650	2006
KL650B2/B3 Tengai KLR650	90-91
KLX650A1/A2/A3/D1 Offroad	93-96
KLX650C1/C2/C3/C4 Dual Sport	93-96

## Yamaha Street

XS400J/K Maxim	82-83
XS400R/RK Seca	82-83
XJ550H/J/K Maxim	81-83
XJ550RH/RJ/RK Seca	81-83
FJ600L/LC/N/NC	84-85
FZ600S/SC/T/TC/U/UC	86-88
YX600S/SC-A/AC Radian	86-90
XJ650G/H/J/K Maxim	80-83
XJ650LH Midnight Maxim	1981
XJ650RJ Seca	1982
XJ650LJ/LK Seca Turbo	82-83
XJ700N/NC/S/SC Maxim	85-86
XJ750J/K Maxim	82-83
XJ750MK Midnight Maxim	1983
XJ750RH/RJ/RK Seca	81-83
XS750D/2D/E/F	77-79
XS750SE/SF Special	78-79
XS850G/H	80-81
XS850LG/LG Midnight Special	80-81
XS850SG/SH Special	80-81
XJ900RK Seca	1982
XJ1100J Maxim	1982
XS1100E/F/G/H	78-81
XS1100LG/LH Midnight Special	80-81
XS1100SF/SG/SH Special	79-81





## 29.5mm Valve Adjustment Shim Kit

Sold as dealer kit and in individual sizes. Individual sizes sold each. See model application list on next column.

### Suzuki 29.5mm Diameter

Dealer Shim Kit 2.30mm - 3.00mm

Order No. **035-020**

Includes storage box and qt 2 each size of the following:  
2.30, 2.35, 2.40, 2.45, 2.50, 2.55, 2.60, 2.65, 2.70, 2.75, 2.80, 2.85, 2.90, 3.00.

Valve Shim Storage Box

Order No. **008-001**

## 29.5mm Valve Adjustment Shims

Sold each. Sizes available from 2.30mm - 3.00mm thickness.

Size	Order No.	Size	Order No.
2.30mm	<b>035-519</b>	2.65mm	<b>035-526</b>
2.35mm	<b>035-520</b>	2.70mm	<b>035-527</b>
2.40mm	<b>035-521</b>	2.75mm	<b>035-528</b>
2.45mm	<b>035-522</b>	2.80mm	<b>035-529</b>
2.50mm	<b>035-523</b>	2.85mm	<b>035-530</b>
2.55mm	<b>035-524</b>	2.90mm	<b>035-531</b>
2.60mm	<b>035-525</b>	3.00mm	<b>035-533</b>



## Z1 Tach Cable Guide Kit

Kit includes tach cable gear holder, o-rings and tach oil seal.

Made in Japan.

Order No: **900-173**

## Kawasaki

Model	Year
Z1/ A/ B-900	73-75
KZ900A4 up to engine 135980	76-77
KZ900B1 LTD up to engine 135980	1976



## Z1 Tachometer Cable

Tachometer cable for the above applications. Sold each.

Order No. **653-601**

## Suzuki

Model	Year
GS400B/XB/C/XC	80-82
GS425EN/LN/N	1983
GS450ET/EX/EZ/ED	80-83
GS450GAZ/GAD	82-83
GS450GAF	1985
GS450LT/LX/LZ/LD	80-83
GS450LF/LG/LH/LJ	85-88
GS450ST/SX	80-81
GS450TX/TXZ/TZ/TXD	84-86
GS500EK/EL/EM/EN/EP/ER/ES/ET/EV/EW/EX/EY	89-00
GS500EK1/EK2	01-02
GS500FK4/FK5/FK6/FK7/FK8/FK9	04-09
GS500HK7/HK8/HK9	07-09
GS550B/C/EC/N/EN/ET	77-80
GS550MZ Katana	1982
GS550TT/TX	80-81
GR650D/XD Tempter	1983
GS650EX/EZ	81-82
GS650GX/GZ/GD	81-83
GS650GLX/GLZ/GLD	81-83
GS650MD Katana	1983
XN85 Turbo	1983
GS750B/C/N/EN/EN	77-79
GS750ET/EX/EZ	80-82
GS750ED/ESD	1983
GS750SD Katana	82-83
GS750TZ/TD	82-83
GS850GN/GT//GX/GZ	80-82
GS850GLT/GLX/GLZ	81-83
GS1000C/EC/N/EN/ET	78-80
GS1000GT/GLT/GX/GLX	80-81
GS1000LN	1979
GS1000SN/ST	79-80
GS1000SZ Katana	1982
GS1100ED/ESD	1983
GS1100ET/EX/EZ	80-82
GS1100GZ/GLZ/GX/GLX	82-83
GS1100GKZ/GK2/GKD/GKE	82-84
GS1100SD Katana	1983

# Engine Valves

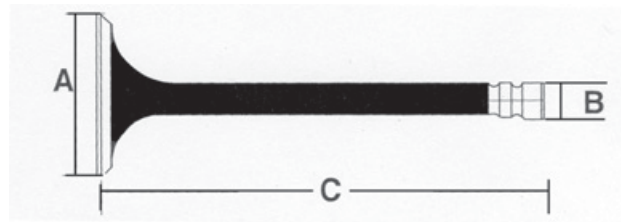

## Vesrah Engine Valves

Sudco offers high performance engine valves manufactured in Japan to the highest quality standards by Fuji. All valves feature advanced technology, stainless steel construction, and tuff tride treatment for a superior product, with high resistance to wear, burn oxidation and corrosion. **Made in Japan.** Valves are sold each. Order per quantity required.

### Honda Street

Model	Year	Intake No.	Exhaust No.
CB125S	76-85	622-1014I	622-1014E
CB750A Automatic	76-77	622-1002I	622-1002E
CB750C Custom	80-82	622-1003I	622-1003E
CB750F Super Sport	75-76	622-1002I	622-1002E
CB750F Super Sport	79-82	622-1003I	622-1003E
CB750K D-K5/K	69-77	622-1002I	622-1002E
CB750K	79-82	622-1003I	622-1003E
CB750L LTD	1979	622-1003I	622-1003E
CB750SC Nighthawk	82-83	622-1003I	622-1003E
VF750C V45 Magna	82-83	622-030I	622-030E
VF750S V45 Sabre	82-83	622-030I	622-030E
CB900C Custom	80-82	622-1006I	622-1006E
CB900F Super Sport	81-82	622-1006I	622-1006E
CB1000C Custom	1983	622-1006I	622-1006E
CBX	79-82	622-1003I	622-1003E
CB1100F Super Sport	1983	622-1006I	622-1006E

### Honda Dual Sport & Offroad

XL125S	79-82	622-1014I	622-1014E
XL125S	1984	622-1014I	622-1014E
XL185S	79-83	622-1014I	622-1014E
XR185	1979	622-1014I	622-1014E
XL200R	83-84	622-1014I	622-1014E
XR200	80-84	622-1014I	622-1014E
XR200R	81-83	622-1014I	622-1014E
XR200R	86-88	622-1014I	622-1014E

### Kawasaki Street

KZ200A1/A2	78-79	622-4012I	622-4012E
KL250A1/A1A/A2	78-79	622-610I	622-610E
KL250A3/A4	80-81	622-4011I	622-4011E
KL250C1/C2	83-84	622-4011I	622-4011E
KL250D2-D22 KLR250	85-05	622-4018I	622-4018E
KZ250D1 LTD	1980	622-4011I	622-4011E
KZ250D2 CSR	1981	622-4011I	622-4011E
KZ250L1 CSR	1982	622-4011I	622-4011E
KZ250W1 LTD	1983	622-4011I	622-4011E
EX305B1 GPz	1983	622-4020I	622-4020E
KZ400B1/B2	78-79	622-604I	622-604E
KZ400H1 LTD	1979	622-604I	622-604E
EN450A LTD454	85-90	622-4018I	622-4018E

### Kawasaki Street

Model	Year	Intake No.	Exhaust No.
EX500A1-A7 Ninja 500R	87-93	622-4018I	622-4018E
KZ550A1/A2/A3	80-82	_____	_____
KZ550C1/C2/C3/C4 LTD	80-83	_____	_____
KZ550D1 GPz	1981	_____	_____
KZ550F1 Spectre	1983	_____	_____
KZ550F2 LTD	1984	_____	_____
KZ550H1/H2 GPz	82-83	_____	_____
KZ550M1 LTD	1983	_____	_____
ZX550A1/A2 GPz	84-85	_____	_____
KL600A1 KLR600 Dual Sport	1984	622-615I	_____
KL600B1/B2 KLR600 Dual Sport	85-86	622-615I	_____
ZL600A1/A2 Eliminator	85-86	622-4023I	622-4023E
ZX600A1/A2/A3 Ninja 600R	85-87	622-4023I	622-4023E
ZX600B1 Ninja 600RX	1987	622-4023I	622-4023E
ZX600C1-C10 Ninja 600R	88-97	622-4023I	622-4023E
KL650A1-A19 KLR650	87-05	622-4015I	_____
KZ650B1/B2/B2A/B3	77-79	622-4008I	_____
KZ650C1/C2/C3	77-79	622-4008I	_____
KZ650C1/C2/C3	77-79	622-4008I	_____
KZ650D1/D1A/D2 SR	78-79	622-4008I	_____
KZ650E1 LTD	1980	622-4008I	_____
KZ650F1	1980	622-4008I	_____
VN750A2-A21 Vulcan 750	86-05	622-4017I	622-4017E
ZI/A/B-900	73-75	622-4001I	622-4001E
KZ900A4/A5	76-77	622-4001I	622-4001E
KZ900B1 LTD	1976	622-4001I	622-4001E
ZL900A1/A2 Eliminator	85-86	622-4018I	622-4018E
ZX900A1/A2/A3 Ninja 900R	84-86	622-4018I	622-4018E
KZ1000A1/A2	77-78	622-4003I	622-4003E
KZ1000A3/A3A/A4 MKII	79-80	622-4003I	622-4003E
KZ1000B1/B2/B3/B4 LTD	77-80	622-4003I	622-4003E
KZ1000C1-C4 Police	78-81	622-4003I	622-4003E
KZ1000D1 Z1R	1978	622-4003I	622-4003E
KZ1000D3 Z1R	1980	622-4003I	622-4003E
KZ1000E1/E2 Shaft ST	79-80	622-4003I	622-4003E
KZ1000G1 LTD Classic	1980	622-4003I	622-4003E
KZ1000J1/J2/J3	81-83	622-4005I	622-4005E
KZ1000K1/K2 LTD	81-82	622-4005I	622-4005E
KZ1000M1/M2 CSR	81-82	622-4005I	622-4005E
KZ1000P1-P22 /Police	82-03	622-4005I	622-4005E
KZ1000R1/R2 Replica	82-83	622-4005I	622-4005E
ZG1000A1-A20 Concours	86-05	622-4018I	622-4018E
ZL1000A1 Eliminator	1987	622-4018I	622-4018E
ZX1000A1/A2 Ninja 1000R	86-87	622-4018I	622-4018E
KZ1100A1/A2/A3 Shaft	81-83	622-4005I	622-4005E
KZ1100B1/B2 GPz	81-82	622-4005I	622-4005E
KZ1100D1/D2 Spectre	82-83	622-4005I	622-4005E
KZ1100L1 LTD Shaft	1983	622-4005I	622-4005E
ZN1100B1/B2 LTD	84-85	622-4015I	622-4015E
ZX1100A1/A2 GPz	83-84	622-4015I	622-4015E
VN1500A1-A9 Vulcan 88	87-90	622-4024I	622-4024E
VN1500B1/B2/B3/B4 Vulcan 88 SE	87-90	622-4024I	622-4024E

## Kawasaki Dual Sport & Offroad

Model	Year	Intake No.	Exhaust No.
KL250A1/A1A/A2	78-79	622-610I	622-610E
KL250A3/A4	80-81	622-4011I	622-4011E
KL250C1/C2	83-84	622-4011I	622-4011E
KL250D2-D22 KLR250	85-05	622-4018I	622-4018E
KL600A1 KLR600	1984	622-615I	————
KL600B1/B2 KLR600	85-86	622-615I	————
KL650A1-A19 KLR650	87-05	622-4015I	————

## Suzuki Street

SP100D Dual Sport	1983	————	————
GN125Z/D	82-83	————	622-3012E
SP125Z/D Dual Sport	82-83	————	————
GN250Z/D	82-83	————	————
GN250F	1985	————	————
GN250J	1988	————	————
SP250Z/D Dual Sport	82-83	————	622-406E
SP250F Dual Sport	1985	————	622-406E
GS550B/C/EC/N/EN	77-79	————	622-433E
GS550ET	1980	————	622-433E
GS550LN/LT/LX/LZ	79-82	————	622-433E
GS550MZ Katana	1982	————	622-433E
GS550TX	1981	————	622-433E
GSX600FJ/FK/FL/FM Katana	88-91	622-3023I	622-3023E
GSX600FW/FX/FY/FK1-FK5 Katana	88-05	622-3023I	622-3023E
GS650EX/EZ	81-82	————	622-433E
GS650GX/GZ/GD	81-83	————	622-433E
GS650GLX/GLZ/GLD	81-83	————	622-433E
GS650MD Katana	1983	————	622-433E
XN85D Turbo	1983	————	622-433E
GS750ET/EX/EZ	80-82	622-3001I	622-3001E
GS750LT/LX	80-81	622-3001I	622-3001E
GS750TZ/TD	82-83	622-3001I	622-3001E
GSX-R750G/H	86-87	622-3019I	622-3019E
GSX-R750RG	1986	622-3019I	622-3019E
GSX-R750J/K	88-89	622-3022I	622-3022E
GS1000C/EC/N/EN/ET	78-80	622-3007I	622-3007E
GS1000GT/GLT/GX/GLX	81-82	622-3007I	622-3007E
GS1000LN	1979	622-3007I	622-3007E
GS1000SN/ST	79-80	622-3007I	622-3007E
GS1000SZ Katana	1982	622-3008I	622-3008E
GS1100ET/EX/EZ/ED/ESD	80-83	622-3008I	622-3008E
GS1100GZ/GLZ/GD/GLD	82-83	622-3007I	622-3007E
GS1100GKZ/GK2/GKD/GKE	82-84	622-3007I	622-3007E
GS1100LT	1980	622-3008I	622-3008E
GS1100SD Katana	1983	622-3008I	622-3008E
GSX1100FJ-FP Katana	88-93	622-3018I	622-3018E
GSX-R1100G/H/J/K/L	86-90	622-3018I	622-3018E

## Suzuki Dual Sport & Offroad

DR100D/E	83-84	————	————
SP100D Dual Sport	1983	————	————
DR125Z/D/E	82-84	————	————
SP125Z/D Dual Sport	82-83	————	————
DR250Z/D	82-83	————	622-406E
DR250F	1985	————	622-406E
SP250Z/D Dual Sport	82-83	————	622-406E
SP250F Dual Sport	1985	————	622-406E

## Yamaha Street

Model	Year	Intake No.	Exhaust No.
SR185H/J Exciter	81-82	622-2013I	622-2013E
XS360C/D/2D	76-77	622-235I	622-235E
XS400D/E/2E/F/2F	77-79	622-235I	622-235E
XS400G/H Special II	80-81	622-235I	622-235E
XS400SG/SH Special	80-81	622-235I	622-235E
XS400SJ Heritage Special	1982	622-235I	622-235E
XS400J/K Maxim	82-83	622-201I	622-201E
XS400R/J/RK Seca	82-83	622-201I	622-201E
SR500E/F/G/H	78-81	622-2011I	622-2007E
XJ550H/J/K Maxim	81-83	622-205I	622-205E
XJ550RH/RJ/RK Seca	81-83	622-205I	622-205E
XZ550R/J/RK Vision	82-83	622-236I	622-205E
XJ650G/H/J/K Maxim	80-83	622-2004I	622-2004E
XJ650LH Midnight Maxim	1981	622-2004I	622-2004E
XJ650LJ/LK Seca Turbo	82-83	622-2004I	622-2004E
XJ650RJ Seca	1982	622-2004I	622-2004E
XJ750J/K Maxim	82-83	622-2004I	622-2004E
XJ750MK Midnight Maxim	1983	622-2004I	622-2004E
XJ750RH/RJ/RK Seca	81-83	622-2004I	622-2004E
XS750D/2D/E/F	77-79	622-201I	622-201E
XS750SE/SF Special	78-79	622-201I	622-201E
XV750H/J/K Virago	81-83	622-2003I	————
XV750MK Midnight Virago	1983	622-2003I	————
XV750U/UC-G/GC Virago	88-95	622-2003I	————
XS850G/H	80-81	622-201I	622-201E
XS850LG/LH Midnight Special	80-81	622-201I	622-201E
XS850SG/SH Special	80-81	622-201I	622-201E
XV920J/K Virago	82-83	622-2011I	622-2011E
XV920MK Midnight Virago	1983	622-2011I	622-2011E
XV920RH/RJ	81-82	622-2011I	622-2011E
XV1000L/LC/N/NC Virago	84-85	622-2011I	622-2011E
XJ1100J Maxim	1982	622-203I	622-203E
XS1100E/F	78-79	622-201I	622-201E
XS1100G/H	80-81	622-209I	622-209E
XS1100LG/LH Midnight Special	80-81	622-209I	622-209E
XS1100SF Special	1979	622-201I	622-201E
XS1100SG/SH Special	80-81	622-209I	622-209E
XV1100S/SC-L/LC Virago	86-99	622-2011I	622-2011E
VMX12N/NC-V/VC V-Max	85-06	622-2019I	622-2019E

## Yamaha Dual Sport & Offroad

BW200N/S Big Wheel	85-86	622-2013I	622-2013E
BW200ES/ET/EU Big Wheel	86-88	622-2013I	622-2013E
TW200T/TC-V/VC Trailway	87-06	622-2013I	622-2013E
XT200J/K/KC Dual Sport	82-83	622-2013I	622-2013E
TT225S/T	86-87	622-2013I	622-2013E
TT500C/D/E/F/G/H	76-81	————	622-2007E
XT500C/D/E/F/G/H Dual Sport	76-81	————	622-2007E
XT550J/K Dual Sport	82-83	622-208I	————

# Valve Stem Seals & Valve Keepers



## Valve Stem Seals & Valve Keepers

Valve Stem Seals are sold pk/10. Valve Keepers sold each. **Made in Japan.** Valve Keeper quantity required for all engine valves is shown after Valve Keeper order number. **Sudco part number + (4) = Qt4, (8) = Qt8.**

### Honda Street

Model	Year	Valve Stem Seal Pk/10	Valve Keeper Each
C70 Passport	80-83	620-001	—
C70K1 Honda 70	72-73	620-001	—
C70M Honda 70	70-71	620-001	—
CL70/K1/K2/K3 Scrambler	69-73	620-001	—
CL90 Scrambler 90	67-69	620-001	—
CB100K0/K1/K2 Super Sport	70-72	620-009	621-001 (4)
CL100K0/K1/K2 Scrambler	70-72	620-009	621-001 (4)
CL100S/S2/S3 Scrambler 100S	71-73	620-009	621-001 (4)
SL100K0/K1/K2/K3 Motosport	70-73	620-009	621-001 (4)
CB125S/S1/S2	73-75	620-009	621-001 (4)
CB125S	1976	620-009	621-001 (4)
CB125S	78-85	620-009	621-001 (4)
CL125S/S1 Scrambler 125	73-74	620-009	621-001 (4)
NX125	88-89	620-006	621-003 (4)
SS125A Super Sport 125	67-69	620-001	—
CA175 (CD175) Touring 175	68-69	620-001	—
CA175K3 Touring 175	69-70	620-001	—
CB175K3-K7 Super Sport 175	69-73	620-001	—
CL175K0 Scrambler 175	68-69	620-001	—
CL175K3-K7 Scrambler 175	69-73	620-001	—
CM185T Twinstar	78-79	620-009	621-001 (8)
CM200T Twinstar	80-82	620-009	621-001 (8)
CM250C	82-83	620-006	621-001 (8)
CMX250C Rebel	85-87	620-006	621-001 (8)
CMX250CD Rebel	1986	620-006	621-001 (8)
VTR250 Interceptor	88-90	620-010	621-002 (16)
CB350F/F1 (4 cylinder)	72-74	620-002	621-001 (16)
CB400A Automatic	1978	620-006 In	621-001 (8) In
		620-012 Ex	— (4) Ex
CB400F Super Sport	75-77	620-002	621-001 (16)
CB400T Hawk	80-81	620-006 In	621-001 (8) In
		620-012 Ex	— (4) Ex
CB400T1/TII Hawk	78-79	620-006 In	621-001 (8) In
		620-012 Ex	— (4) Ex
CM400A Automatic	79-80	620-006 In	621-001 (8) In
		620-012 Ex	— (4) Ex
CM400C Custom	1981	620-006 In	621-001 (8) In
		620-012 Ex	— (4) Ex
CM400E	80-81	620-006 In	621-001 (8) In
		620-012 Ex	— (4) Ex
CM400T	79-81	620-006 In	621-001 (8) In
		620-012 Ex	— (4) Ex
CB450SC Nighthawk	82-86	620-006 In	621-001 (8) In
		620-012 Ex	— (4) Ex
CB450T Hawk	1982	620-006 In	621-001 (8) In
		620-012 Ex	— (4) Ex
CM450A Automatic	82-83	620-006 In	621-001 (8) In
		620-012 Ex	— (4) Ex
CM450C Custom	1982	620-006 In	621-001 (8) In
		620-012 Ex	— (4) Ex
CM450E	82-83	620-006 In	621-001 (8) In
		620-012 Ex	— (4) Ex
CMX450C Rebel	86-87	620-006 In	621-001 (8) In
		620-012 Ex	— (4) Ex

### Honda Street

Model	Year	Valve Stem Seal Pk/10	Valve Keeper Each
CM450C Custom	1982	620-006 In	621-001 (8) In
		620-012 Ex	— (4) Ex
CM450E	82-83	620-006 In	621-001 (8) In
		620-012 Ex	— (4) Ex
CMX450C Rebel	86-87	620-006 In	621-001 (8) In
		620-012 Ex	— (4) Ex
CB500/K1/K2	71-73	620-002	621-001 (16)
CX500	78-79	620-002	—
CX500C Custom	79-82	620-002	—
CX500D Deluxe	79-81	620-002	—
CX500TC	1982	620-002	—
FT500 Ascot	82-83	620-005	—
GL500 Silverwing	81-82	620-002	—
GL500I Silverwing Interstate	81-82	620-002	—
VF500C V30 Magna	84-85	620-010	621-002 (32)
VF500F Interceptor	84-86	620-010	621-002 (32)
VT500C Shadow 500	83-86	620-006 In	621-003 (8) In
		620-012 Ex	— (4) Ex
VT500FT Ascot	83-84	620-006 In	621-003 (8) In
		620-012 Ex	— (4) Ex
CB550F Super Sport	75-77	620-002	621-001 (16)
CB550/K1/K	74-78	620-002	621-001 (16)
CBR600F Hurricane	87-90	620-010	621-002 (32)
VT600C Shadow VLX	88-89	620-006 In	621-003 (8) In
		620-005 Ex	— (4) Ex
NT650 Hawk GT	88-91	620-006 In	621-003 (8) In
		620-012 Ex	— (4) Ex
NX650	88-89	620-005	—
CB650	79-82	620-009	621-001 (16)
CB650C Custom	80-81	620-009	621-001 (16)
CB650SC Nighthawk	1982	620-002	621-001 (16)
CB650SC Nighthawk 650	83-85	620-010	621-002 (32)
CX650C Custom	1983	620-002	—
CX650T Turbo	1983	620-002	—
GL650 Silverwing	1983	620-002	—
GL650I Silverwing Interstate	1983	620-002	—
CB700SC Nighthawk	84-85	620-010	621-002 (32)
VF700C Magna	84-87	620-006	621-003 (32)
VF700F Interceptor	84-85	620-006	621-003 (32)
VF700S Sabre	84-85	620-006	621-003 (32)
VFR700F/F2 Interceptor	86-87	620-006	621-003 (32)
VT700C Shadow	84-87	620-005	—
CB750A Automatic	76-78	620-002	—
CB750C Custom	80-82	620-006	621-001 (32)
CB750F Super Sport	75-78	620-002	—
CB750F Super Sport	79-82	620-006	621-001 (32)
CB750K0/K1-K5 750 Four	69-75	620-002	—
CB750K 750 Four	1976	620-002	—
CB750K 750 Four K	77-78	620-002	—
CB750K 750 Four K	79-82	620-006	621-001 (32)
CB750L LTD	1979	620-006	621-001 (32)
CB750SC Nighthawk	82-83	620-006	621-001 (32)
VF750C V45 Magna	82-83	620-006	621-001 (32)

## Honda Street

Model	Year	Valve Stem Seal Pk/10	Valve Keeper Each
VF750C V45 Magna	1988	620-006	621-003 (32)
VF750F Interceptor	83-84	620-006	621-003 (32)
VF750S V45 Sabre	82-83	620-006	621-001 (32)
VFR750F Interceptor	1986	620-006	621-003 (32)
VT750C Shadow 750	1983	620-002	—
VT800C Shadow	1988	620-005	—
CB900C Custom	80-82	620-006	621-001 (32)
CB900F Super Sport	81-82	620-006	621-001 (32)
CB1000C Custom	1983	620-006	621-001 (32)
CBR1000F Hurricane	87-88	620-006	621-003 (32)
GL1000 Gold Wing	75-79	620-002	—
GL1000L LTD	1976	620-002	—
VF1000F Interceptor	1984	620-006	621-003 (32)
VF1000R	85-86	620-006	621-003 (32)
CBX six cyl. Super Sport	79-82	620-006	621-001 (48)
CB1100F Super Sport	1983	620-006	621-001 (32)
GL1100 Gold Wing	80-83	620-005	—
GL1100A Goldwing Aspencade	82-83	620-005	—
GL1100I Goldwing Interstate	80-83	620-005	—
VF1100C V65 Magna	83-86	620-006	621-003 (32)
VF1100S V65 Sabre	84-85	620-006	621-003 (32)
VT1100C Shadow 1100	85-90	620-005	—
GL1200 Gold Wing	1984	620-005	—
GL1200A Aspencade	84-87	620-005	—
GL1200I Interstate	84-87	620-005	—
GL1200L Limited	1985	620-005	—
GL1200SEi Aspencade	1986	620-005	—
GL1500 Goldwing	88-90	620-006	—

## Kawasaki Street

\*KZ400 (74-77) & \*KZ550A/C applications, (1980-1981). Order valve keeper required. Difference is keeper groove on valves.

KZ200A1/A2	78-79	620-601	621-604 (4)
EL250B2/B3 Eliminator	88-89	620-604	621-605 (16)
EX250E1/E2 Ninja 250R	86-87	620-604	621-605 (16)
EX250F2/F3/F4 Ninja 250R	88-90	620-604	621-605 (16)
KZ250D1/D2 LTD & CSR	80-81	620-601	621-604 (4)
KZ250L1 CSR	1982	620-601	621-604 (4)
KZ250W1 LTD	1983	620-601	621-604 (4)
EX305B1 GPz Belt	1983	620-603	621-603 (8)
KZ305A1/A2 CSR	81-82	620-603	621-603 (8)
KZ305B1 CSR Belt	1981	620-603	621-603 (8)
KZ305B2/B3 LTD	87-88	620-603	621-603 (8)
KZ400A1/A2 Deluxe	77-78	620-601	621-604 (8)
KZ400B1/B2	78-79	620-601	621-604 (8)
KZ400C1	1978	620-601	621-604 (8)
KZ400/D *	74-75	620-601	621-606 (8)
up to engine 089779			
KZ400/D/D3/D4 *	74-77	620-601	621-604 (8)
from engine 089779			
KZ400H1 LTD	1979	620-601	621-604 (8)
KZ400S/S2/S3 Special *	75-77	620-601	621-606 (8)
up to engine 089779			
KZ400S/S2/S3 Special *	75-77	620-601	621-604 (8)
from engine 089779			
KZ440A1/A2/A3/A4 LTD	80-83	620-601	621-604 (8)
KZ440B1/B2	80-81	620-601	621-604 (8)
KZ440D1/D2/D3/D4/D5 LTD	80-83	620-601	621-604 (8)
KZ440G1 Belt	1982	620-601	621-604 (8)
EN450A1-A6 LTD 454	85-90	620-603	621-603 (16)
EX500A1-A7	87-93	620-603	621-603 (16)
KZ550A1/A2 *	80-81	620-604	621-602 (16)
KZ550A1/A2 *	80-81	620-604	621-603 (16)
KZ550A3/A4	82-83	620-604	621-603 (16)
KZ550C1/C2 LTD *	80-81	620-604	621-602 (16)
KZ550C1/C2 LTD *	80-81	620-604	621-603 (16)
KZ550C3/C4 LTD	82-83	620-604	621-603 (16)

## Kawasaki Street

Model	Year	Valve Stem Seal Pk/10	Valve Keeper Each
KZ550D1 GPz	1981	620-604	621-603 (16)
KZ550F1 Spectre	1983	620-604	621-603 (16)
KZ550F2 LTD Shaft	1984	620-604	621-603 (16)
KZ550H1/H2 GPz	82-83	620-604	621-603 (16)
ZX550A1/A2/A3 GPz	84-86	620-604	621-603 (16)
KL600A1 KLR600	1984	620-601	621-604 (8)
KL600B1/B2 KLR600	85-86	620-604	621-604 (8)
ZL600A1/A2 Eliminator	86-87	620-604	621-605 (32)
ZX600A1/A2/A3 Ninja 600R	85-87	620-604	621-605 (32)
ZX600B1 Ninja 600RX	1987	620-604	621-605 (32)
ZX600C1-C10 Ninja 600R	88-97	620-604	621-605 (32)
KL650A1-A19 KLR650	87-05	620-601	621-604 (8)
KZ650B1/B2/B2A/B3	77-79	620-601	621-604 (16)
KZ650C1/C2/C3 Custom	77-79	620-601	621-604 (16)
KZ650D1/D1A SR	1978	620-601	621-604 (16)
KZ650D2 SR	1979	620-601	621-604 (16)
KZ650E1 LTD	1980	620-601	621-604 (16)
KZ650F1	1980	620-601	621-604 (16)
KZ650H1/H2/H3 CSR	81-83	620-601	621-604 (16)
KZ700A1	1984	620-601	621-604 (16)
VN700A1 Vulcan	1985	620-603	621-603 (16)
ZN700A1/A2 LTD	84-85	620-601	621-604 (16)
KZ750B1/B2/B3/B4 2-cyl.	76-79	—	621-601 (8)
KZ750E1/E2/E3	80-82	620-601	621-604 (16)
KZ750F1 LTD Shaft	1983	620-601	621-604 (16)
KZ750G1 LTD 2-cyl.	1980	—	621-601 (8)
KZ750H1/H2/H3/H4 LTD	80-83	620-601	621-604 (16)
KZ750K1/K2 LTD 2-cyl.	83-84	—	621-601 (8)
KZ750L3	1983	620-601	621-604 (16)
KZ750M1 CSR 2-cyl.	1982	—	621-601 (8)
KZ750N1/N2 Spectre	82-83	620-601	621-604 (16)
KZ750R1 GPz	1982	620-601	621-604 (16)
VN750A2-A21 Vulcan 750	86-05	620-603	621-603 (16)
ZX750A1/A2/A3 GPz	83-85	620-601	621-604 (16)
ZX750E1/E2 GPz Turbo	84-85	620-601	621-604 (16)
ZX750F1/F2/F3/F4 Ninja 750R	87-90	620-604	621-605 (32)
KZ900A4/A5	76-77	620-601	621-606 (16)
KZ900B1 LTD	1976	620-601	621-606 (16)
KZ900C2 Police	1976	620-601	621-606 (16)
Z1/A/B-900	73-75	620-601	621-606 (16)
ZL900A1/A2 Eliminator	85-86	620-603	621-603 (32)
ZX900A1/A2/A3 Ninja 900R	84-86	620-603	621-603 (32)
KZ1000A1/A2	77-78	620-601	621-604 (16)
KZ1000A3/A3A/A4 MKII	79-80	620-601	621-604 (16)
KZ1000B1/B2/B3/B4 LTD	77-80	620-601	621-604 (16)
KZ1000C1/C1A/C2/C3/C4 Police	78-81	620-601	621-604 (16)
KZ1000D1 Z1R	1978	620-601	621-604 (16)
KZ1000D3 Z1R	1980	620-601	621-604 (16)
KZ1000E1/2 Shaft ST	79-80	620-601	621-604 (16)
KZ1000J1/J2/J3	81-83	620-601	621-604 (16)
KZ1000K1/K2 LTD	81-82	620-601	621-604 (16)
KZ1000M1/M2 CSR	81-82	620-601	621-604 (16)
KZ1000P1-P21 Police	82-02	620-601	621-604 (16)
KZ1000R1/R2 Replica	82-83	620-601	621-604 (16)
ZG1000A1-A20 Concours	86-05	620-603	621-603 (32)
ZL1000A1 Eliminator	1987	620-603	621-603 (32)
ZX1000A1/A2 Ninja 1000R	86-87	620-603	621-603 (32)
ZX1000B1/B2/B3 Ninja ZX-10	88-90	620-604	621-605 (32)
KZ1100A1/A2/A3 Shaft	81-83	620-601	621-604 (16)
KZ1100B1/B2 GPz	81-82	620-601	621-604 (16)
KZ1100D1/D2 Spectre	82-83	620-601	621-604 (16)
KZ1100L1 LTD	1983	620-601	621-604 (16)
ZN1100B1/B2 LTD Shaft	84-85	620-601	621-604 (16)
ZX1100A1/A2 GPz	83-84	620-601	621-604 (16)
ZG1200A1 Voyager XII	1986	620-603	621-603 (32)
ZG1200B1-B17 Voyager XII	87-03	620-603	621-603 (32)
KZ1300A1/A2/A3/A4	79-82	620-601	621-604 (24)

# Valve Stem Seals & Valve Keepers

## Suzuki Street

Model	Year	Valve Stem Seal Pk/10	Valve Keeper Each
SP100D Dual Sport	1983	620-401	_____
GN125Z/D	82-83	620-401	_____
SP125Z/D Dual Sport	82-83	620-401	_____
SP200G/H/J Dual Sport	86-88	620-401	_____
GN250Z/D	82-83	620-401	_____
GN250F	1985	620-401	_____
GN250J	1988	620-401	_____
GS250TT/TX	80-81	620-401	_____
SP250Z/D Dual Sport	82-83	620-401	_____
SP250F Dual Sport	1985	620-401	_____
GS300LZ/LD	82-83	620-401	_____
GS300LF	1985	620-401	_____
GN400T/TX/TZ	80-82	620-402	621-401 (4)
GN400XT/XX	80-81	620-402	621-401 (4)
GS400B/XB/X/XC	77-78	620-402	621-401 (8)
SP400T Dual Sport	1980	620-402	621-401 (4)
GS425N/EN/LN	1979	620-402	621-401 (8)
GS450ET/EX/EZ/ED	80-83	620-402	621-401 (8)
GS450GAZ/GAD Automatic	82-83	620-402	621-401 (8)
GS450GAF Automatic	1985	620-402	In _____ _____ Ex 621-401 (4)
GS450LT/LXLZ/LD	80-83	620-402	621-401 (8)
GS450LF/LG/LH/LG	85-88	620-402	In _____ _____ Ex 621-401 (4)
GS450ST/SX	80-81	620-402	621-401 (8)
GS450TX/TXZ/TXD	81-83	620-402	621-401 (8)
SP500X/Z/D	81-83	620-402	621-401 (4)
GS550B/C/EC/N/EN/ET	77-80	620-402	621-401 (16)
GS550ED/ESD	1983	620-403	621-405 (32)
GS550ES3/ESE/EF/ESF/ESG	83-86	620-403	621-405 (32)
GS550LN/LT/LX/LZ	79-82	620-402	621-401 (16)
GS550LD	1983	620-403	621-405 (32)
GS550LF/LG	85-86	620-403	621-405 (32)
GS550MZ Katana	1982	620-402	621-401 (16)
GS550TX	1981	620-402	621-401 (16)
GSX600FJ-FY Katana	88-00	620-404	621-405 (32)
SP600F Dual Sport	1985	620-402	621-401 (8)
GR650D/XD Tempter	1983	620-402	_____
GS650EX/EZ	81-82	620-402	621-401 (16)
GS650GX/GZ/GD	81-83	620-402	621-401 (16)
GS650GLX/GLZ/GLD	81-83	620-402	621-401 (16)
GS650MD Katana	1983	620-402	621-401 (16)
LS650FFG/FFH Savage	86-87	620-402	_____
LS650FPG/FPH/FPJ Savage	86-88	620-402	_____
XN85D Turbo	1983	620-402	621-401 (16)
GS700EF/EFS	1985	620-401	_____
GV700GLF/GLF2 Madura	1985	620-401	_____
VS700GLFG/GLFH Intruder	86-87	620-401	_____
VS700GLPG/GLPH Intruder	86-87	620-401	_____
VS700GLEFG/GLEFH Intruder	86-87	620-401	_____
VS700GLEPG/GLEPH Intruder	86-87	620-401	_____
GS750B/C/N/EC/EN	77-79	620-402	621-401 (16)
GS750ET/EX/EZ	80-82	620-401	_____
GS750ED/ESD	1983	620-401	_____
GS750LN	1979	620-402	621-401 (16)
GS750LT/LX	80-81	620-401	_____
GS750SD Katana	1983	620-401	_____
GS750TZ/TD	82-83	620-401	_____
GSX-R750G/H	86-87	620-404	621-405 (32)
GSX-R750RG	1986	620-404	621-405 (32)
GSX-R750J/K/L/N/M	88-92	620-404	621-405 (32)
VS750GLPJ-GLPM Intruder	88-91	620-401	_____
GS850GN/GT/GX/GZ/GD	79-83	620-402	621-401 (16)
GS850GLT/GLX/GLZGLD	80-83	620-402	621-401 (16)
GS1000C/EC/N	78-79	620-402	621-401 (16)

## Suzuki Street

Model	Year	Valve Stem Seal Pk/10	Valve Keeper Each
GS1000EN/ET	79-80	620-402	621-401 (16)
GS1000GT/GLT/GX/GLX	80-81	620-402	621-401 (16)
GS1000LN	1979	620-402	621-401 (16)
GS1000SN	1979	620-402	621-401 (16)
GS1000SZ Katana	1982	620-401	_____
GS1100ET/EX/EZ	80-82	620-401	_____
GS1100ED/ESD	1983	620-401	_____
GS1100GZ/GLZ/GD/GLD	82-83	620-402	621-401 (16)
GS1100GKZ-GKE	82-84	620-402	621-401 (16)
GS1100LT	1980	620-401	_____
GS1100SD Katana	1983	620-401	_____
GSX-R1100G/H/J/K/L/M/N	86-92	620-404	621-405 (32)
GSX1100FJ-FP Katana	88-93	620-404	621-405 (32)
GS1150ES3/ESE/ESF	83-85	620-401	_____
GS1150EF/EF2/EG/ESG	85-86	620-401	_____
GV1200GLF/GLF2/GLG Madura	85-86	620-401	_____
GV1400GCG/GCH Cavalcade	86-87	620-403	621-405 (32)
GV1400GDG/GDH/GDJ Cavalcade	86-88	620-403	621-405 (32)
GV1400GTG/GTH Cavalcade	86-87	620-403	621-405 (32)
VS1400GLFH-GLFN Intruder	87-92	620-401	In _____ 620-402 Ex _____
VS1400GLPH-GLPK4 Intruder	87-04	620-401	In _____ 620-402 Ex _____

## Yamaha Street

XT125J/K/KC Dual Sport	82-83	620-203	621-201 (4)
SR185H/J Exciter	81-82	620-203	621-201 (4)
TW200T/TC-V/VC Trailway	87-06	620-203	621-201 (4)
XT200J/K/KC Dual Sport	82-83	620-203	621-201 (4)
SR250G/H/J Exciter	80-82	620-201	_____
SR250TH Exciter	1981	620-201	_____
SRX250T/TC	1987	620-204	_____
XT250G/H/J/K/KC Dual	80-83	620-201	_____
XT250L/LC Dual Sport	1984	620-204	_____
XV250U/UC/W/WC/A/AC	88-90	620-206	_____
XT350N/NC-M/MC Dual Sport	85-00	620-204	_____
XS360C/D	76-77	620-201	_____
FZR400U/SUC/W/SWC/A/SAC	88-90	620-207	_____
XS400D/E/2E/F/2F	77-79	620-201	_____
XS400E/2E	78-79	620-201	_____
XS400G/H Special II	80-81	620-201	_____
XS400J/K Maxim	82-83	620-201	_____
XS400RJ/RK Seca	82-83	620-201	_____
XS400SG/SH Special	80-81	620-201	_____
XS400SJ Heritage Special	1982	620-201	_____
SR500E/F/G/H	78-81	620-202	_____
TX500/A	73-74	620-204	_____
XS500B/C/D/E	75-78	620-204	_____
XT500C/D/E/F/G/H Dual Sport	76-81	620-202	_____
XV500K Virago	1983	620-201	_____
XV535T/TC/U/UC Virago	87-88	620-201	_____
XJ550H/J/K Maxim	81-83	620-203	621-201 (16)
XJ550RH/RJ/RK Seca	81-83	620-203	621-201 (16)
XT550J/K Dual Sport	82-83	620-201	_____
XZ550RJ/RK Vision	82-83	620-204	621-201 (16)
FJ600L/LC/N/NC	84-85	620-203	621-201 (16)
FZ600S/SC/T/TC/U/UC	86-88	620-203	621-201 (16)
SRX600S/SC	1986	620-201	_____
XJ600SD/SDC-SK/SKC Seca II	92-98	620-205	_____
XT600L/LC-EG/EGC Dual Sport	84-95	620-201	_____
YX600S/SC-A/AC Radian	86-90	620-204	621-201 (16)
XJ650G/H/J/K Maxim	80-83	620-201	_____
XJ650LH Midnight Maxim	1981	620-201	_____
XJ650LJ/LK Seca Turbo	82-83	620-201	_____
XJ650RJ Seca	1982	620-201	_____

## Yamaha Street

Model	Year	Valve Stem Seal Pk/10	Valve Keeper Each
XS1/XS1B/XS2-650	70-72	620-202	—
TX650/A	73-74	620-202	—
XS650B/C/D/E/F/2F	75-79	620-202	—
XS650G/H Special II	80-81	620-202	—
XS650SE/SF/SG Special	78-80	620-202	—
XS650SH/SJ/SK Heritage Special	81-83	620-202	—
XVS650K/KC-T/TC V-Star Custom	98-05	620-201	—
FZ700T/TC	1987	620-205	—
FZX700S/SC/T/TC Fazer	86-87	620-205	—
XJ700N/NC/S/SC Maxim	85-86	620-201	—
XJ700XN/XNC/XS/XSC Maxim	85-86	620-201	—
XV700L/LC/N/NC Virago	84-85	620-202	—
XV700CS/CSC/CT/CTC Virago	86-87	620-202	—
XV700SS/SSC Virago	1986	620-202	—
FZ750N/S/SC	85-86	620-205	—
FZ750U/UC	1988	620-205	—
FZR750RT/RU	87-88	620-205	—
TX750/A	73-74	620-201	—
XJ750J/K Maxim	82-83	620-201	—
XJ750MK Midnight Maxim	1983	620-201	—
XJ750RH/RJ/RK Seca	81-83	620-201	—
XS750D/2D/E/F	77-79	620-201	—
XS750SE/SF Special	78-79	620-201	—
XV750H/J/K Virago	81-83	620-202	—
XV750MK Midnight Virago	1983	620-202	—
XV750U/UC-H/HC Virago	88-96	620-201	—
XS850G/H	80-81	620-201	—
XS850LG/LH Midnight Special	80-81	620-201	—
XS850SG/SH Special	80-81	620-201	—
XJ900RK Seca	1983	620-201	—
XV920J/K Virago	82-83	620-202	—
XV920MK Midnight Virago	1983	620-202	—
FZR1000T/TC/U/UC	87-88	620-205	—
XV1000L/LC/N/NC Virago	84-85	620-202	—
FJ1100L/LC/N/NC	84-85	620-204	—
XJ1100J Maxim	1982	620-201	—
XS1100E/F/G/H	78-81	620-201	—
XS1100LG/LH Midnight Special	80-81	620-201	—
XS1100SF/SG/SH Special	79-81	620-201	—
XV1100S/SC-L/LC Virago	86-99	620-202	—
FJ1200S/SC/T/TC	86-87	620-204	—
VMX12N/NC/S/SC V-Max	85-86	620-204	—
VMX12U/UC-V/VC V-Max	88-06	620-204	—
XVZ12TK/L/KC2 Venture	83-84	—	621-201 (32)
XVZ12TDK Venture Royale	1983	—	621-201 (32)
XVZ12DL/DKC2/DN Venture Royale	84-85	—	621-201 (32)
XVZ13T/TC/U/UC Venture	87-88	—	621-201 (32)



## APE High Performance Valve Guides

APE valve guides are made from special bronze alloy to resist wear and heat. Precision machined with the bores finished to size. They are designed to fit lower in the cylinder head to clear high lift cams, and use APE seals or factory OEM seals. Sold in sets for models listed.

## Honda

Model	Year	APE No.	Order No.
750 SOHC	69-78	VGH750	875-200

## Kawasaki

KZ650 thru KZ1100	2-Valve	VGK900	875-210
ZX1000 Ninja ZX10	88-90	VGK1100K	875-211
ZX1100 Ninja ZX11	90-01	VGK1100K	875-211

## Suzuki

GS750/1100/1150	4 valve	VGS1100S	875-220
GSXR750/1100	thru 1992	VG750GSX	875-221
GSXR750W	93-95	VG1100GSX	875-222
GSXR1100W	93-98	VG1100GSX	875-222

## Specials (oversize)

Kawasaki Z1/KZ1000/GPZ1100004"	99101-4	875-240
Kawasaki Z1/KZ1000/GPZ11000025"	99101-25	875-241

oversize repair guide (.502 dia)



## APE Titanium Valve Spring Retainers

APE valve spring retainers are machined from aircraft quality titanium bar stock in the APE plant on the latest state of the art computerized CNC machinery. Sold in sets.

Models listed in Engine section on page 352.



## APE High Performance Valve Springs

APE valve guides are made from special bronze alloy to resist wear and heat. Precision machined with the bores finished to size. They are designed to fit lower in the cylinder head to clear high lift cams, and use APE seals or factory OEM seals. Sold in sets.

Models listed in Engine section on page 352.

# Cam Chain Tensioners

## APE Manual Cam Chain Tensioners for Vintage Applications

A Must for any kind of performance riding. APE manual cam chain tensioners are CNC machined from billet alloy to exact tolerances for perfect fit. Designed to replace the automatic and hydraulic tensioners on high performance engines. The automatic adjusters can back out when the throttle is suddenly closed at high rpm. This allows the cams to go momentarily out of time and can result in bent valves and/or serious engine damage. Hydraulic tensioners have a tendency to put too much tension on the chain guide under high rpm/high oil pressure conditions resulting in premature wear. Both problems can be eliminated with the installation of the APE manual cam chain tensioner. No matter what the engine does, the cam chain tensioner will remain constant. Cam Chain Tensioners are sold each.



### Kawasaki

#### Cam Chain Tensioner

Model	Year	APE No.	Order No.	Cometic No.	Order No.
EX500	87-08	KT1050	<a href="#">875-415</a>	_____	_____
ZX600A Ninja 600R	85-87	KT1100	<a href="#">875-416</a>	comes with o-ring	_____
VN750A Vulcan 750 (*qt2 required)	86-03	KT1100	<a href="#">875-416*</a>	comes with o-ring	_____
KZ900A4/A5	76-77	KT1000	<a href="#">875-418</a>	EC067	<a href="#">875-782</a>
KZ900B1 LTD	1976	KT1000	<a href="#">875-418</a>	EC067	<a href="#">875-782</a>
Z1/A/B-900	73-75	KT1000	<a href="#">875-418</a>	EC067	<a href="#">875-782</a>
ZX900A Ninja 900R	84-86	KT1050	<a href="#">875-415</a>	_____	_____
KZ1000A1/A2/A2A	77-78	KT1000	<a href="#">875-418</a>	EC067	<a href="#">875-782</a>
KZ1000A3/A3A/A4 MKII	79-80	KT1000	<a href="#">875-418</a>	EC067	<a href="#">875-782</a>
KZ1000B1/B2/B3/ B4 LTD	77-80	KT1000	<a href="#">875-418</a>	EC067	<a href="#">875-782</a>
KZ1000C1/C1A/C2/C3/C4 Police	78-81	KT1000	<a href="#">875-418</a>	EC067	<a href="#">875-782</a>
KZ1000D1 Z1R	1978	KT1000	<a href="#">875-418</a>	EC067	<a href="#">875-782</a>
KZ1000D3 Z1R	1980	KT1000	<a href="#">875-418</a>	EC067	<a href="#">875-782</a>
KZ1000E1/E2 Shaft ST	79-80	KT1000	<a href="#">875-418</a>	EC067	<a href="#">875-782</a>
KZ1000J	81-83	KT1100	<a href="#">875-416</a>	comes with o-ring	_____

### Suzuki Street

GSX-R750 oil cooled	86-92	ST750	<a href="#">875-402</a>	EC065	<a href="#">875-781</a>
GS1100/1150	all	ST1100	<a href="#">875-404</a>	EC062	<a href="#">875-789</a>
GSX-R1100 oil cooled	87-92	ST750	<a href="#">875-402</a>	EC065	<a href="#">875-781</a>

### Yamaha Street

FJ1100	84-85	YT1000	<a href="#">875-435</a>	EC019	<a href="#">875-780</a>
FJ1200	86-93	YT1000	<a href="#">875-435</a>	EC019	<a href="#">875-780</a>

## APE Kawasaki Cam Chain Idler Adapter

This adapter allows the use of later model GPz 1100 or KZ1000J cylinder head on earlier model KZ900/KZ1000 lower end. It maintains the roller style cam chain. This is the only modification necessary to install the big valve head on early motor. Use with OEM KZ sprockets or high performance aftermarket versions.

Description	APE No.	Order No.
Cam Chain Idler Adapter with Pin	CCIA	<a href="#">875-450</a>







950-191

## Cam Chain Tensioner Pushrod Kit

Each kit contains 4 pieces: 1 push rod (5mm longer than stock), 2 heavy duty springs and tensioner block gasket. Improves cam chain function, prevents cam chain noise and extends cam chain life.

**Made in Japan.** Available for the following Kawasaki models.

### Kawasaki

PRK-101	Order No. 950-191
Model	Year
KZ1000J1/J2/J3	81-83
KZ1000K1/K2 LTD	81-82
KZ1000M1/M2 CSR	81-82
KZ1000P1-P21 Police	82-02
KZ1000R1/R2 Replica	82-83
KZ1100A1/A2/A3 Shaft	81-83
KZ1100B1/B2 GPz	81-82
KZ1100D1/D2 Spectre	82-83
KZ1100L1 LTD	1983
ZN1100B1/B2 LTD Shaft	84-85
ZX1100A1/A2 GPz	83-84

PRK-102	Order No. 950-192
Model	Year
KZ650H1/H2/H3 CSR	81-83
KZ700A1	1984
ZN700A1/A2 LTD	84-85
KZ750E1/E2/E3	80-82
KZ750F1 LTD Shaft	1983
KZ750H1/H2/H3/H4 LTD	80-83
KZ750L3	1983
KZ750N1/N2 Spectre	82-83
KZ750R1 GPz	1982
ZR750C1/C2/C3 Zephyr	91-93
ZX750A1/A2/A3 GPz	83-85

PRK-103	Order No. 950-193
Model	Year
KZ550A1/A2/A3/A4	80-83
KZ550C1/C2/C3/C4 LTD	80-83
KZ550D1 GPz	1981
KZ550F1/F2 Spectre & LTD	83-84
KZ550H1/H2 GPz	82-83
KZ550M1 LTD	1983
ZR550B1/B2/B3/B4 Zephyr	90-93
ZX550A1/A2 GPz	84-85

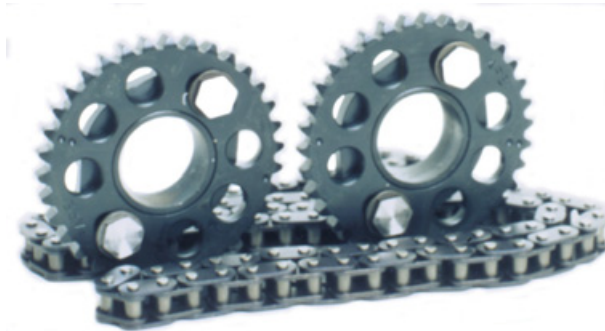

## APE Adjustable Cam Sprocket Assemblies

**For models with Factory OEM Bolt on Sprockets**

APE manufactures the original "billet" adjustable cam sprockets. APE sprockets are necessary for precise cam timing to achieve maximum performance. APE sprockets are fully machined on the latest state of the art computerized equipment to precision tolerances and fully heat treated for extra long wear life. Its cam sprockets are used by most leading racers who demand top performance along with the safety of not chancing their expensive racing heads to reworked stock sprockets.

### Kawasaki

Model	Year	APE No	Order No
Z1/A/B-900	73-75	ACS900K	875-500
KZ900A4/A5	76-77	ACS900K	875-500
KZ1000A1/A2	77-78	ACS900K	875-500
KZ1000A3/A4 MKII	79-80	ACS1000K	875-501
KZ1000B1/B2 LTD	77-78	ACS900K	875-500
KZ1000B3/B4 LTD	79-80	ACS1000K	875-501
KZ1000D1 Z1R	1978	ACS900K	875-500
KZ1000D3 Z1R	1980	ACS1000K	875-501
KZ1000E1/E2 Shaft	79-80	ACS1000K	875-501
KZ1000J1/J2/J3	81-83	ACS1100K	875-503
KZ1000K1/K2	81-82	ACS1100K	875-503
KZ1000M1/M2	81-82	ACS1100K	875-503
KZ1000P Police	82-05	ACS1100K	875-503
KZ1000R1/R2 Replica	82-83	ACS1100K	875-503
KZ1000 (w/32T)		ACS1000K	875-501
ZX1100A GPz	83-84	ACS1100K	875-503

### Suzuki

GSXR750G/H	86-87	ACS750S	875-521
GS1100E	80-83	ACS1100S	875-524
GS1150E	83-86	ACS1100S	875-524
GSXR1100	86-92	ACS1100GSX	875-522

### Yamaha

FJ1100	84-85	ACS1100FJ	875-534
FJ1200	86-93	ACS1100FJ	875-534

# Cam Chains



313-130

## Sudco Cam Chains for Vintage Models

Sudco cam chains are stock replacements for the models listed. Cam Chains available are endless. Master links are not available. **Made in Japan.** Available for the following models:

### Honda Street

Model	Year	Cam Chain Number x Links	Order No
CB750A Automatic	76-78	BF05M x 94L	311-015
CB750F Super Sport	76-78	BF05M x 94L	311-015
CB750K0/K1/K2/K3/K4/K5	69-75	BF05M x 94L	311-015
CB750K	76-78	BF05M x 94L	311-015

### Kawasaki Street

KZ400A1/A2 Deluxe	77-78	BF05T x 88L	313-088
KZ400B1/B2/C1	78-79	BF05T x 88L	313-088
KZ400/D/D3/D4	74-77	BF05T x 88L	313-088
KZ400H1 LTD	1979	BF05T x 88L	313-088
KZ400S/S2/S3 Special	75-77	BF05T x 88L	313-088
KZ650B1/B2/B2A/B3	77-79	BF05T x 118L	311-001
KZ650C1/C2/C3 Custom	77-79	BF05T x 118L	311-001
KZ650D1/D1A/D2 SR	78-79	BF05T x 118L	311-001
KZ650E1 LTD	1980	BF05T x 118L	311-001
KZ650F1	1980	BF05T x 118L	311-001
KZ750B1/B2/B3/B4	76-79	BF05T x 130L	313-130
KZ750G1 LTD	1980	BF05T x 130L	313-130
Z1/Z1A/Z1B-900	73-75	BS05MH x 122L	311-027
KZ900A4/A5	76-77	BS05MH x 122L	311-027
KZ900B1 LTD	1976	BS05MH x 122L	311-027
KZ1000A1/A2/A2A	77-78	BS05MH x 122L	311-027
KZ1000A3/A3A/A4 MKII	79-80	BS05MH x 124L	311-028
KZ1000B1/B2/B3 LTD	77-79	BS05MH x 122L	311-027
KZ1000B4 LTD	1980	BS05MH x 124L	311-028
KZ1000C1/C1A/C2 Police	78-79	BS05MH x 122L	311-027
KZ1000C3/C4 Police	80-81	BS05MH x 124L	311-028
KZ1000D1 Z1R	1978	BS05MH x 122L	311-027
KZ1000D3 Z1R	1980	BS05MH x 124L	311-028
KZ1000E1/E2 Shaft ST	79-80	BS05MH x 124L	311-028
KZ1000G1 LTD Classic	1980	BS05MH x 124L	311-028

### Suzuki Street

GS550B/C/EC/N/EN/ET	77-80	BF05M x 116L	311-016
GS550LN/LT/LX/LZ	79-82	BF05M x 116L	311-016
GS550MZ Katana	1982	BF05M x 116L	311-016
GS550TX	1981	BF05M x 116L	311-016
GSX600FJ/FK/FL/FM Katana	88-91	BF05M x 116L	311-016
GSX600FN/FP/FR/FS/FT Katana	92-96	BF05M x 116L	311-016
GS650EX/EZ	81-82	BF05M x 116L	311-016
GSX750FK-FV Katana	89-97	BF05M x 118L	311-017
GSX-R750G/H	86-87	BF05M x 116L	311-016
GSX-R750RG	1986	BF05M x 116L	311-016
GSX-R750J/K	88-89	BF05M x 118L	311-017
GSX-R750L/M/N	90-92	BF05M x 116L	311-016



July 1972

## Yamaha Street

FZR400U/SUC/W/SWC/A/SAC	88-90	BF04MA x 112L	311-010
FZR600W/WC/AC	89-90	BF04MA x 118L	311-011
FZR600RA/RAC-RL/RLC	90-99	BF04MA x 118L	311-011
FZ700T/TC	1987	BS05MH x 110L	311-026
FZX700S/SC/T/TC Fazer	86-87	BS05MH x 110L	311-026
FZ750N/S/SC	85-86	BS05MH x 110L	311-026
FZR750RT/RU	87-88	BS05MH x 110L	311-026
FZR1000T/TC/U/UC	87-88	BS05MH x 110L	311-026
FZR1000W/WC-G/GC	89-95	BS05MH x 108	311-025
XJ1100J Maxim	1982	BF05M x 128L	311-018
XS1100E/F/G/H	78-81	BF05M x 128L	311-018
XS1100LG/LH Midnight Special	80-81	BF05M x 128L	311-018
XS1100SF/SG/SH Special	79-81	BF05M x 128L	311-018
VMX12N/NC-T/TC V-Max	86-05	BF05M x 118L	311-017
VMX12V/VC V-Max	2006	BF05M x 118L	311-017



## Motion Pro Chain Breaker & Riveting Tool

This tool is versatile enough to be used on cam chains or drive chains. 2mm breaking tip for most cam chains, 3mm breaking tip for chains #25-#35 only, and 4mm breaking tip for drive chain #428-#630, it is recommended to grind the rivet head. Each kit includes 3 pin sizes to fit most chains (2.2mm, 2.9mm, 3.8mm) and press plates. with plastic storage box and instructions.

Order No. 950-420

### Replacement Parts

Description	Order No.
2mm Replacement Tip	950-421
3mm Replacement Tip	950-422
4mm Replacement Tip	950-423
Replacement Rivet Tip	950-424



## Piston Rings

Made in Japan to OEM specifications. Sold in sets for one piston. Order qt required. Use with OEM Pistons.

### Honda

Model	Year	Size	OEM Reference	Order No.
CB900C Custom	80-82	0.25	13021-438-004	624-115R
CB900F Super Sport	81-82	0.25	13021-438-004	624-115R
CBX (1047cc)	79-82	0.25	13021-438-004	624-115R
GL1000K Goldwing	75-79	0.25	13021-371-004	624-120R
GL1000L Goldwing LTD	1976	0.25	13021-371-004	624-120R
GL1100 Goldwing	80-83	0.25	13021-463-000	624-124R
GL1100A Aspencade	82-83	0.25	13021-463-000	624-124R
GL1100I Interstate	80-83	0.25	13021-463-000	624-124R

### Kawasaki

KZ400A1/A2 Deluxe	77-78	0.50	13025-5013	624-651R
KZ400D/D3/D4	75-77	0.50	13025-5013	624-651R
KZ400S/S2/S3 Special	75-77	0.50	13025-5013	624-651R
KZ440A1/A2/A3/A4 LTD	80-83	0.50	13025-5015	624-654R
KZ440B1/B2	80-81	0.50	13025-5015	624-654R
KZ440D1/D2/D3/D4/D5 LTD Belt	80-83	0.50	13025-5015	624-654R
KZ440G1 Belt	1983	0.50	13025-5015	624-654R
H2/A/B/C-750 Mach IV	72-75	0.50	13025-045	624-675R

### Suzuki

GS450ET/EX/EZ	80-82	0.50	12140-44110-050	624-451R
GS450GAZ/GAD Automatic	82-83	0.50	12140-44110-050	624-451R
GS450GAF Automatic	1985	0.50	12140-44110-050	624-451R
GS450LT/LX/LZ/LD	80-83	0.50	12140-44110-050	624-451R
GS450LF/LG/LH/LJ	85-88	0.50	12140-44110-050	624-451R
GS450TX/TZ/TXZ/TXD	81-83	0.50	12140-44110-050	624-451R
GS550B/C/EC/N/EN/ET	77-80	0.50	12140-47031-050	624-454R
GS550LN/LT/LX/LZ	79-82	0.50	12140-47031-050	624-454R
GS550MZ	1982	0.50	12140-47031-050	624-454R
GS550TX	1981	0.50	12140-47031-050	624-454R
GS850GN/GT/GX/GZ/GD	79-83	0.50	12140-45120-050	624-466R
GS850GLT/GLX/GLZ/GLD	80-83	0.50	12140-45120-050	624-466R
GS1000C /EC/N/EN	78-79	0.50	12140-49001-050	624-469R
GS1000ET	1980	0.50	12140-49001-050	624-469R
GS1000GT/GX	80-81	0.50	12140-49001-050	624-469R
GS1000LN	1979	0.50	12140-49001-050	624-469R
GS1000SN/ST	80-81	0.50	12140-49001-050	624-469R
GS1100ET/EX/EZ/ED	80-83	0.50	12140-49220-050	624-472R
GS1100GZ/GLZ/GD/GLD	82-83	0.50	12140-49220-050	624-472R

### Yamaha

RD400C/D/E/F	76-79	0.25	1A1-11601-25-00	624-251R
XV750H/J/K Virago	81-83	Std.	4X7-11610-00-00	624-271R
XV750MK Midnight Virago	1983	Std.	4X7-11610-00-00	624-271R



## Motion Pro 4-Stroke Leakdown Tester

Checks percentage of cylinder leakage in a 4-stroke engine. Tester includes 10, 12, and 14mm spark plug adapters, regulator and gauge.

Order No. 950-401

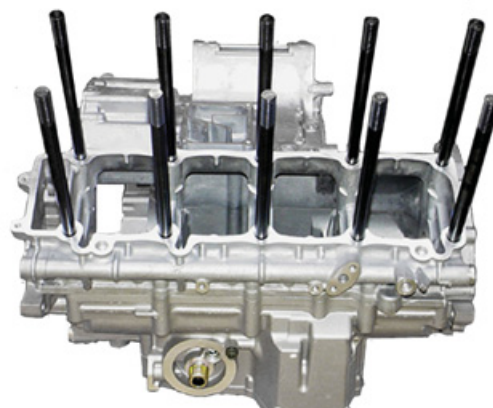

## Heavy Duty Cylinder Head Studs

Heavy duty cylinder studs are necessary to prevent head gasket leakage in high compression and turbocharged engines. Stock studs are made from poor material that will stretch and allow gasket leakage. APE studs are made from heat treated chrome moly and have rolled threads for maximum strength. Sold in sets.

### Honda

CB750 SOHC	thru 78	CS750H	875-140
------------	---------	--------	---------

### Kawasaki

KZ650/KZ750 2 valve fours	CS650K	875-100
KZ900/KZ1000/KZ1100	CS900K	875-102

### Suzuki

GS1000 2 valve	CS1000S	—
GS1100	CS1100S	875-121
GS1150	CS1150S	875-122
GSXR1100, 1127cc case (40mm starter hole)	CS1127GSX	875-125

### Yamaha

FJ1100/FJ1200	CS1100FJ	875-164
---------------	----------	---------

See Page 351 for Heavy Duty Cylinder Head Nuts

# Oil Seal Kits & Crankshaft Seal



504-001



504-351

## Sudco Engine Oil Seal Kits

Kits contain OEM seals required for engine rebuild. *Made in Japan.*

### Honda

Model	Year	Order No.
CB350F/F1 Supersport	72-74	504-002
CB400F Super Sport	75-77	504-002
CB750K0/K1/K2/K3/K4/K5	69-75	504-001

### Kawasaki

H1/A/B/C/D/E-500 Mach III	69-74	504-060
H2/A/B/C-750 Mach IV	72-75	504-061
Z1/A/B-900	73-75	504-065
KZ900A4	1976	504-065
KZ900B1 LTD	1976	504-065
KZ1000A1/A2	77-78	504-065
KZ1000A3/A3A/A4 MKII	79-80	504-065
KZ1000B1/B2/B3/B4 LTD	77-80	504-065
KZ1000D1 Z1R	1978	504-065
KZ1000D3 Z1R	1980	504-065
KZ1000E1/E2 Shaft	79-80	504-065
KZ1000G1 Classic LTD	1980	504-065

### Yamaha

RD350/A/B 2-stroke	73-75	504-044
RD400C/D/E 2-stroke	76-78	504-044



## K&S Engine Oil Seal Kits

Motorcycle engine oil seal kits for a complete engine rebuild. Available for the following applications.

### Honda

Model	Year	Order No.
GB500	89-90	504-016
NX650	88-89	504-016

### Yamaha

RZ350L/N/NC/NCII	84-85	504-042
------------------	-------	---------

## Kawasaki Crankshaft Oil Seal Kits

Crankshaft (crank) oil seal kits include inner and outer seals. Sold in kits and each.

### Kawasaki

#### Crankshaft Oil Seals - S3-400/KH400

Description	Qt	Order No.
Crankshaft Oil Seal Kit	4/pc kit	504-352
Left Side Outer	Each	504-316
Left Side Inner	Each	504-305
Right Side Inner	Each	504-305
Right Side Outer	Each	504-312

#### Model

Model	Year
KH250A5	1976
S1A/B/C-250	73-75
S2/A-350	72-73
S3/A-400	74-75
KH400A3/A4/A5	76-78

#### Crankshaft Oil Seals - H1-500

Crankshaft Oil Seal Kit	4/pc kit	504-351
Left Side Outer	Each	504-311
Left Side Inner	Each	504-301
Right Side Inner	Each	504-302
Right Side Outer	Each	504-312

#### Model

H1/A/B/C/D/E/F-500 Mach III	69-75
KH500A8 (2-stroke triple)	1976

#### Crankshaft Oil Seals- H2-750

Crankshaft Oil Seal Kit	4/pc kit	504-350
Left Side Outer	Each	504-313
Left Side Inner	Each	504-303
Right Side Inner	Each	504-304
Right Side Outer	Each	504-314

#### Model

H2/A/B/C-750 Mach IV	72-75
----------------------	-------



## Oil Pump Banjo Bolt Washer Kit

Oil pump banjo bolt washer kit for KH250 1976, S1-250 73-75, S3-350 72-73, KH-400 76-78, S3-400 74-75, H1-500 69-75, H2-750 72-75

Order No.	901-321
-----------	---------



623-699

## Sudco Kawasaki H1 & H2 Connecting Rod Kits

Sudco connecting rod kits are *Made in Japan* to meet or exceed OEM specifications. Kits contain crank pin, connecting rod, upper and lower pin bearing and thrust washers. Sold in kits. Crank Pin and Connecting Rod sold individually as shown.

### Kawasaki H1-500

Description	Order No.
Connecting Rod Kit	623-699
Connecting Rod only	623-650
Crank Pin only	900-135
Applications	Year
H1/A/B/C/D/E/F-500 Mach III	69-75
KH500A8 2-stroke triple	1976

### Kawasaki H2-750-Piston Pin Bearing not included

Description	Order No.
Connecting Rod Kit	623-698
Applications	Year
H2/A/B/C-750 Mach IV	72-75



## Vesrah Connecting Rod Kits

Vesrah connecting rod kits include connecting rod, crank pin bearing, crank pin, and thrust washers (as required). *Made in Japan..*

### Kawasaki Street

KZ200A1/A1A/A2	78-79	VA-4001	623-601
KZ250W1 LTD Belt	1983	VA-4004	623-604



504-340

## Crankshaft Seal Collar Sets

Three piece sets include two center crankshaft seal collars and one outside crankshaft seal collar.

### Kawasaki

Model	Year	Order No.
H1/A/B/C/D/E/F-500 Mach III	69-75	504-341
H2/A/B/C-750 Mach IV	72-75	504-340



005-198



005-199

## K&N Rubber Base Crankcase Vent Filters

Filters are designed to clamp directly to metal or plastic tubing. Ideal for engines, transmissions, oil and gas tanks on racing vehicles. Sold each.

Rubber Top				
Flange I.D.	Filter Diameter	Filter Height	K&N No.	Order No.
1-1/4"	3"	2-1/2"	62-1380	005-198
Chrome Top				
1-1/4"	3"	2-1/2"	62-1390	005-199



005-195



005-196



005-197

## K&N Steel Base Crankcase Vent Filters

One piece design for competition use. 2" O.D. x 1-1/2" long (height) with rubber top. All base plates are chrome plated. Sold each.

Vent Tube Diameter	K&N No.	Order No.
1/2"	62-1010	005-195
5/8"	62-1020	005-196
3/4"	62-1030	005-197

# Clutch Cover Gaskets



643-1016

## Clutch Cover Gaskets

Made in Japan. Sold each

### Honda Street

Model	Year	Vesrah Ref	Order No.
CB125S	81-82	VL-1016	643-1016
CB350F/F1 Super Sport	72-74	VL-1014	643-1014
CB350G	1973	VL-1013	643-1013
CB350/K1-K4 Super Sport	68-73	VL-1013	643-1013
CL350/K1-K5 Scrambler	68-73	VL-1013	643-1013
SL350K0/K1/K2 Motosport	69-73	VL-1013	643-1013
CB400F Super Sport	75-77	VL-1008	643-1008
FT500 Ascot	82-83	VL-1041	643-1041
VF500C V30 Magna	84-85	VL-1049	643-1049
VF500F V30 Interceptor	84-85	VL-1049	643-1049
CBR600F Hurricane	87-90	VL-1070	643-1070
VT600C Shadow VLX	88-89	VL-1071	643-1071
NT650 Hawk GT	88-91	VL-1071	643-1071
NX650	88-89	VL-1028	643-1028
CB700SC Nighthawk	84-86	VL-1050	643-1050
VF700F Interceptor	84-85	VL-1021	643-1021
VF700S Sabre	84-85	VL-1021	643-1028
VFR700F/F2 Interceptor	86-87	VL-1064	643-1064
VT700C Shadow	84-87	VL-1040	643-1040
CB750A Automatic	76-78	VL-1001	643-1001
CB750C Custom	80-82	VL-1002	643-1002
CB750F Super Sport	75-78	VL-1001	643-1001
CB750F Super Sport	79-82	VL-1002	643-1002
CB750K0/K1-K5 750 Four	69-75	VL-1001	640-1001
CB750K 750 Four	76-78	VL-1001	640-1001
CB750K	79-82	VL-1002	643-1002
CB750L LTD	1979	VL-1002	643-1002
CB750SC Nighthawk	82-83	VL-1002	643-1002
VF750C V45 Magna	82-83	VL-1021	643-1021
VF750C V45 Magna	1988	VL-1021	643-1021
VF750F V45 Interceptor	83-84	VL-1021	643-1021
VF750S V45 Sabre	82-83	VL-1021	643-1028
VT800C Shadow	1988	VL-1040	643-1040
CB900C Custom	80-82	VL-1002	643-1002
CB900F Super Sport	81-82	VL-1002	643-1002
CB1000C Custom	1983	VL-1002	643-1002
CBR1000F Hurricane	87-88	VL-1077	643-1077
GL1000 Goldwing	75-79	VL-1039	643-1039
GL1000L Goldwing LTD	1976	VL-1039	643-1039
VF1000F Interceptor	1984	VL-1021	643-1021
VF1000R	85-86	VL-1021	643-1021
CB1100F Super Sport	1983	VL-1002	643-1002
GL1100 Goldwing	80-83	VL-1032	643-1032
GL1100A Goldwing Aspencade	82-83	VL-1032	643-1032
GL1100I Goldwing Interstate	80-83	VL-1032	643-1032
VF1100C V65 Magna	83-86	VL-1058	643-1058
VF1100S V65 Sabre	84-85	VL-1058	643-1058
VT1100C Shadow	85-90	VL-1060	643-1060
GL1200 Goldwing	1984	VL-1066	643-1066
GL1200A Goldwing Aspencade	84-87	VL-1066	643-1066
GL1200I Goldwing Interstate	84-87	VL-1066	643-1066
GL1200L Goldwing LTD	1985	VL-1066	643-1066
GL1200SEi Goldwing Aspencade	1986	VL-1066	643-1066
GL1500 Goldwing	88-90	VL-1081	643-1081

## Kawasaki Street

Model	Year	Vesrah Ref	Order No.
KZ400B1/B2	78-79	VL-4025	643-4025
KZ400C1	1978	VL-4025	643-4025
KZ400H1 LTD	1979	VL-4025	643-4025
KZ440A1/A2/A3/A4 LTD	80-83	VL-4025	643-4025
KZ440B1/B2	80-81	VL-4025	643-4025
KZ440D1/D2/D3/D4/D5 LTD Belt	80-83	VL-4025	643-4025
KZ440G1 Belt	1982	VL-4025	643-4025
EN450A1-A6 LTD 454	85-90	VL-4039	643-4039
EX500A1-A7	87-93	VL-4039	643-4039
KZ550A1/A2/A3/A4	80-83	VL-4024	643-4024
KZ550C1/C2/C3/C4 LTD	80-83	VL-4024	643-4024
KZ550D1 GPz	1981	VL-4024	643-4024
KZ550F1 Spectre	1983	VL-4024	643-4024
KZ550F2 LTD	1984	VL-4024	643-4024
KZ550H1/H2 GPz	82-83	VL-4024	643-4024
KZ550M1 LTD	1983	VL-4024	643-4024
ZX550A1/A2/A3 GPz	84-86	VL-4024	643-4024
KL600A1 KLR600	1984	VL-4013	643-4013
KL600B1/B2 KLR600	85-86	VL-4013	643-4013
ZL600A1/A2 Eliminator	86-87	VL-4035	643-4035
ZX600A1/A2/A3 Ninja 600R	85-87	VL-4035	643-4035
ZX600B1 Ninja 600RX	1987	VL-4035	643-4035
ZX600C1-C10 Ninja 600R	88-97	VL-4035	643-4035
KL650A1-A19 KLR650	87-05	VL-4013	643-4013
KZ650B1/B2/B2A/B3	77-79	VL-4005	643-4005
KZ650C1/C2/C3 Custom	77-79	VL-4005	643-4005
KZ650D1/D1A/D2 SR	78-79	VL-4005	643-4005
KZ650E1 LTD	1980	VL-4005	643-4005
KZ650F1	1980	VL-4005	643-4005
KZ650H1/H2/H3 CSR	81-83	VL-4005	643-4005
KZ700A1	1984	VL-4005	643-4005
ZN700A1/A2 LTD	84-85	VL-4005	643-4005
KZ750B1/B2/B3/B4 2-cylinder	76-79	VL-4002	643-4002
KZ750E1/E2/E3	80-82	VL-4005	643-4005
KZ750F1/F2 Spectre & LTD	83-84	VL-4005	643-4005
KZ750G1 LTD 2-cylinder	1980	VL-4002	643-4002
KZ750H1/H2/H3/H4 LTD	80-83	VL-4005	643-4005
KZ750K1/K2 2-cylinder	83-84	VL-4002	643-4002
KZ750L3	1983	VL-4005	643-4005
KZ750M1 CSR 2-cylinder	1983	VL-4002	643-4002
KZ750N1/N2 Spectre	82-83	VL-4002	643-4002
KZ750R1 GPz	1982	VL-4002	643-4002
ZX750A1/A2/A3 GPz	83-85	VL-4002	643-4002
ZX750E1/E2 GPz Turbo	84-85	VL-4002	643-4002
KZ900A4/A5	76-77	VL-4001	643-4001
KZ900B1 LTD	1976	VL-4001	643-4001
Z1/Z1A/Z1B-900	73-75	VL-4001	643-4001
ZL900A1/A2 Eliminator	85-86	VL-4014	643-4014
ZX900A1/A2/A3 Ninja 900R	84-86	VL-4014	643-4014
KZ1000A1/A2	77-78	VL-4001	643-4001
KZ1000A3/A3A/A4 MKII	79-80	VL-4001	643-4001
KZ1000B1/B2/B3/B4 LTD	77-80	VL-4001	643-4001
KZ1000C1/C1A/C2/C3/C4 Police	78-81	VL-4001	643-4001
KZ1000D1 Z1R	1978	VL-4001	643-4001
KZ1000D3 Z1R	1980	VL-4001	643-4001
KZ1000E1/E2 Shaft ST	79-80	VL-4001	643-4001
KZ1000G1 Classic LTD	1980	VL-4001	643-4001
KZ1000J1/J2/J3	81-83	VL-4004	643-4004
KZ1000K1/K2 LTD	81-82	VL-4004	643-4004
KZ1000M1/M2 CSR	81-82	VL-4004	643-4004
KZ1000P1-P21 Police	82-02	VL-4004	643-4004
KZ1000R1/R2 Replica	82-83	VL-4004	643-4004
ZG1000A1-A14 Concours	86-99	VL-4014	643-4014
ZL1000A1 Eliminator	1987	VL-4014	643-4014
ZX1000A1/A2 Ninja 1000R	86-87	VL-4014	643-4014
ZX1000B1/B2/B3 Ninja ZX-10	88-90	VL-4014	643-4014
KZ1100A1/A2/A3 Shaft	81-83	VL-4004	643-4004
KZ1100B1/B2 GPz	81-82	VL-4004	643-4004
KZ1100D1/D2 Spectre	82-83	VL-4004	643-4004
KZ1100L1 LTD	1983	VL-4004	643-4004

## Suzuki Street

Model	Year	Vesrah Ref	Order No.
GS450ET/EX/EZ/ED	80-83	VL-3006	<b>643-3006</b>
GS450LT/LX/LZ/LD	80-83	VL-3006	<b>643-3006</b>
GS450LF/LG/LH/LJ	85-88	VL-3006	<b>643-3006</b>
GS450ST/SX	80-81	VL-3006	<b>643-3006</b>
GS450TX/TZ	81-82	VL-3006	<b>643-3006</b>
GS450TX/TZ/TXZ/TXD	81-83	VL-3006	<b>643-3006</b>
GSX600FJ-FK5 Katana	88-05	VL-3039	<b>643-3039</b>
GS700EF/ESF	1985	VL-3016	<b>643-3016</b>
GS750B/C/EC/N/EN/LN	77-79	VL-3001	<b>643-3001</b>
GS750ET/EX/EZ	80-83	VL-3007	<b>643-3007</b>
GS750ED/ESD	1983	VL-3016	<b>643-3016</b>
GS750LT/LX	80-81	VL-3007	<b>643-3007</b>
GS750SD Katana	1983	VL-3007	<b>643-3007</b>
GS750TZ/TD	82-83	VL-3007	<b>643-3007</b>
GSX-R750G/H/J/K/L/M/N	86-92	VL-3039	<b>643-3039</b>
GSX-R750RG	1986	VL-3039	<b>643-3039</b>
GS850GN/GT/GLT/GX/GLX	79-81	VL-3001	<b>643-3001</b>
GS850GZ/GLZ/GD/GLD	82-83	VL-3009	<b>643-3009</b>
GS1000C/EC/N	78-79	VL-3002	<b>643-3002</b>
GS1000EN/ET	80-81	VL-3002	<b>643-3002</b>
GS1000GT/GX/GZ/GD	80-83	VL-3009	<b>643-3009</b>
GS1000GLT/GLX/GLZ/GLD	80-83	VL-3009	<b>643-3009</b>
GS1000LN	1979	VL-3009	<b>643-3009</b>
GS1000SN/ST	79-80	VL-3002	<b>643-3002</b>
GS1000SZ Katana	1983	VL-3008	<b>643-3008</b>
GS1100ET/EX/EZ/ED/ESD	80-83	VL-3008	<b>643-3008</b>
GS1100GKZ/GK2/GKD/GKE	82-84	VL-3009	<b>643-3009</b>
GS1100LT	1980	VL-3008	<b>643-3008</b>
GS1100SD Katana	1983	VL-3008	<b>643-3008</b>
GSX1100FJ-FP Katana	88-93	VL-3039	<b>643-3039</b>
GSX-R1100G/H/J/K/L/M/N	86-92	VL-3039	<b>643-3039</b>
GS1150ES3/EF/EF2/ESE/ESF	83-85	VL-3008	<b>643-3008</b>
GS1150EG/ESG	1986	VL-3008	<b>643-3008</b>
VS1400GLPH-GLPY Intruder	87-00	VL-3066	<b>643-3066</b>

## Yamaha Street

RX50K	1983	VL-2024	<b>643-2024</b>
RX50MKMidnight	1983	VL-2024	<b>643-2024</b>
YSR50T/U/W/A/B/D	87-92	VL-2024	<b>643-2024</b>
RD125LC Watercooled (Europe)	82-84	VL-2030	<b>643-2030</b>
SR185H/J Exciter	81-82	VL-2017	<b>643-2017</b>
TW200T/TC-T1/T1C Trailway	87-05	VL-2012	<b>643-2012</b>
RD250LC Watercooled (Europe)	80-82	VL-2011	<b>643-2011</b>
XT250L/LC Dual Sport	1984	VL-2037	<b>643-2037</b>
RD350LC Watercooled (Europe)	80-85	VL-2011	<b>643-2011</b>
RZ350L/N/NC/NCII	84-85	VL-2011	<b>643-2011</b>
XT350N/NC-M/MC Dual Sport	85-00	VL-2037	<b>643-2037</b>
FZR400U/SUC/W/SWC/A/SAC	88-90	VL-2052	<b>643-2052</b>
SR500E/F/G/H	78-81	VL-2003	<b>643-2003</b>
XJ550H/J/K Maxim	81-83	VL-2006	<b>643-2006</b>
XJ550RH/RJ/RK Seca	81-83	VL-2006	<b>643-2006</b>
XT550J/K Dual Sport	82-83	VL-2013	<b>643-2013</b>
FJ600L/LC/N/NC	84-85	VL-2006	<b>643-2006</b>
FZ600S/SC/T/TC/U/UC	86-88	VL-2006	<b>643-2006</b>
SRX600S/SC	1986	VL-2013	<b>643-2013</b>

## Yamaha Street

Model	Year	Vesrah Ref	Order No.
XT600L/LC-EG/EGC Dual Sport	84-95	VL-2013	<b>643-2013</b>
YX600S/SC-A/AC Radian	86-90	VL-2006	<b>643-2006</b>
XJ650G/H/J/K Maxim	80-83	VL-2022	<b>643-2022</b>
XJ650LH Midnight Maxim	1981	VL-2022	<b>643-2022</b>
XJ650LJ/LK Seca Turbo	82-83	VL-2022	<b>643-2022</b>
XJ650RJ Seca	1982	VL-2022	<b>643-2022</b>
XS1-650	1970	VL-2002	<b>643-2002</b>
XS1B-650	1971	VL-2002	<b>643-2002</b>
XS2-650	1972	VL-2002	<b>643-2002</b>
TX650/A	73-74	VL-2002	<b>643-2002</b>
XS650B/C/D/E/F	75-79	VL-2002	<b>643-2002</b>
XS6502F	1979	VL-2002	<b>643-2002</b>
XS650SE/SF Special	78-79	VL-2002	<b>643-2002</b>
XS650G/H Special II	80-81	VL-2002	<b>643-2002</b>
XS650SG/SH Special	80-81	VL-2002	<b>643-2002</b>
XS650SJ/SK Heritage Special	82-83	VL-2002	<b>643-2002</b>
FZ700T/TC	1987	VL-2045	<b>643-2045</b>
FZX700S/SC/T/TC Fazer	86-87	VL-2045	<b>643-2045</b>
XV700L/LC/N/NC Virago	84-85	VL-2005	<b>643-2005</b>
XV700CS/CSC/CT/CTC Virago	86-87	VL-2005	<b>643-2005</b>
XV700SS/SSC Virago	1986	VL-2005	<b>643-2005</b>
FZ750N/S/SC	85-86	VL-2045	<b>643-2045</b>
FZ750U/UC	1988	VL-2045	<b>643-2045</b>
FZR750RT/RU	87-88	VL-2045	<b>643-2045</b>
XS750D/2D/E/F	77-79	VL-2004	<b>643-2004</b>
XS750SE/SF Special	78-79	VL-2004	<b>643-2004</b>
XJ750J/K Maxim	82-83	VL-2022	<b>643-2022</b>
XJ750MK Midnight Maxim	1983	VL-2022	<b>643-2022</b>
XJ750RH/RJ/RK Seca	81-83	VL-2022	<b>643-2022</b>
XV750H/J/K Virago	81-83	VL-2005	<b>643-2005</b>
XXV750MK Midnight Virago	1983	VL-2005	<b>643-2005</b>
XV750U/UC-K/KC Virago	88-98	VL-2005	<b>643-2005</b>
XS850G/H	80-81	VL-2004	<b>643-2004</b>
XS850LG/LH Special	80-81	VL-2004	<b>643-2004</b>
XS850SG/SH Midnight Special	80-81	VL-2004	<b>643-2004</b>
XJ900RKSeca	1983	VL-2022	<b>643-2022</b>
XV920J/K Virago	82-83	VL-2005	<b>643-2005</b>
XV920MK Midnight Virago	1983	VL-2005	<b>643-2005</b>
XV920RH/RJ	81-82	VL-2005	<b>643-2005</b>
XV1000L/LC/N/NC Virago	84-85	VL-2005	<b>643-2005</b>
FZR1000T/TC/U/UC/W/WC/A/AC	87-90	VL-2045	<b>643-2045</b>
XJ1100J Maxim	1982	VL-2004	<b>643-2004</b>
XS1100E/F/G/H	78-81	VL-2004	<b>643-2004</b>
XS1100LG/LH Midnight Special	80-81	VL-2004	<b>643-2004</b>
XS1100SF/SG/SH Special	79-81	VL-2004	<b>643-2004</b>
XV1100S/SC-L/LC Virago	86-99	VL-2005	<b>643-2005</b>
FJ1200S/SC/T/TC	86-87	VL-2048	<b>643-2048</b>



# Point Cover Gaskets



642-4002



642-3006

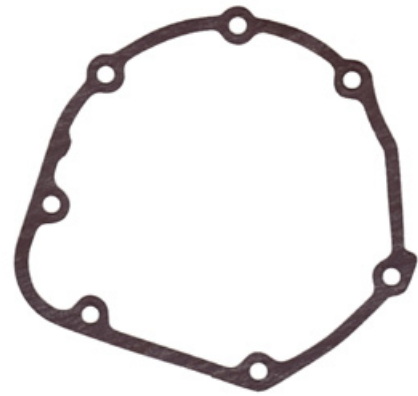

640-4026

## Ignition Cover Gaskets (Point & Pulser)

Sold each. *Made in Japan.*

### Honda

Model	Year	Vesrah Ref	Order No.
CB500K0/K1/K2	71-73	VZ-1001	642-1001
CB550F Super Sport	75-77	VZ-1001	642-1001
CB550K0/K1	74-75	VZ-1001	642-1001
CB550K	76-78	VZ-1001	642-1001
CB750A Automatic	76-78	VZ-1001	642-1001
CB750C Custom	80-82	VK-1009	641-1009
CB750F Super Sport	75-78	VZ-1001	642-1001
CB750F Super Sport	79-82	VK-1009	641-1009
CB750K0/K1/K2/K3/K4/K5	69-75	VZ-1001	642-1001
CB750K	76-78	VZ-1001	642-1001
CB750K	79-82	VK-1009	641-1009
CB750L LTD	1979	VK-1009	641-1009
CB750SC Nighthawk	82-83	VK-1009	641-1009
CB900C Custom	80-82	VK-1009	641-1009
CB900F Super Sport	81-82	VK-1009	641-1009
CB1000C Custom	1983	VK-1009	641-1009
CB1100F Super Sport	1983	VK-1009	641-1009

### Kawasaki

Z1/A/B-900	73-75	VZ-4002	642-4002
KZ900A4/A5	76-77	VZ-4002	642-4002
KZ900B1 LTD	1976	VZ-4002	642-4002
ZL900A1/A2 Eliminator	85-86	VY-4026	640-4026
ZX900A1/A2/A3 Ninja 900R	84-86	VY-4026	640-4026
KZ1000A1/A2	77-78	VZ-4002	642-4002
KZ1000A3/A3A/A4 MKII	79-80	VZ-4002	642-4002
KZ1000B1/B2/B3/B4 LTD	77-80	VZ-4002	642-4002
KZ1000C1/C1A/C2/C3/C4 Police	78-81	VZ-4002	642-4002
KZ1000D1 Z1R	1978	VZ-4002	642-4002
KZ1000D3 Z1R	1980	VZ-4002	642-4002
KZ1000E1/E2 Shaft	79-80	VZ-4002	642-4002
KZ1000G1 Classic LTD	1980	VZ-4002	642-4002
KZ1000J1/J2/J3	81-83	VU-4001	648-4001
KZ1000K1/K2 LTD	81-82	VU-4001	648-4001
KZ1000M1/M2 CSR	81-82	VU-4001	648-4001
KZ1000P1-P22 Police	82-02	VU-4001	648-4001
KZ1000R1/R2 Replica	82-83	VU-4001	648-4001
ZG1000A1-A20 Concours	86-05	VY-4026	640-4026
ZL1000A1 Eliminator	1987	VY-4026	640-4026
ZX1000A1/A2 Ninja 1000R	86-87	VY-4026	640-4026
ZX1000B1/B2/B3 Ninja ZX-10	88-90	VY-4026	640-4026
KZ1100A1/A2/A3 Shaft	81-83	VU-4001	648-4001
KZ1100B1/B2 GPz	81-82	VU-4001	648-4001
KZ1100D1/D2 Spectre	82-83	VU-4001	648-4001
KZ1100L1 1100 LTD Shaft	1983	VU-4001	648-4001
ZN1100B1/B2 1100 LTD Shaft	84-85	VU-4001	648-4001
ZX1100A1/A2 GPz	83-84	VZ-4001	648-4001

### Suzuki

Model	Year	Vesrah Ref	Order No.
GSX600FJ-FK5 Katana	88-05	VZ-3006	642-3006
GS650GLX/GLZ	81-82	VZ-3003	642-3003
GS650GX/GZ	81-82	VZ-3003	642-3003
GS750B/C/EC/N/EN	77-79	VZ-3002	642-3002
GS750ET/EX	80-81	VZ-3003	642-3003
GS750LN	1979	VZ-3002	642-3002
GS750LT/LX	80-81	VZ-3003	642-3003
GS750TZ/TD	82-83	VZ-3003	642-3003
GSX-R750RG	1986	VZ-3006	642-3006
GSX-R750G/H/J/K/L/M/N	86-92	VZ-3006	642-3006
GS850GN/GT/GX/GZ/GD	79-83	VZ-3002	642-3002
GS850GLT/GLX/GLZ/GLD	80-83	VZ-3002	642-3002
GS1000C/EC/N/EN/ET	78-80	VZ-3002	642-3002
GS1000GT/GX	80-81	VZ-3002	642-3002
GS1000GLT/GLX	80-81	VZ-3002	642-3002
GS1000LN	1979	VZ-3002	642-3002
GS1000SN/ST	79-80	VZ-3002	642-3002
GS1000SZ Katana	1982	VZ-3003	642-3003
GS1100ET/EX	80-81	VZ-3003	642-3003
GS1100GZ/GD	82-83	VZ-3002	642-3002
GS1100GLZ/GLD	82-83	VZ-3002	642-3002
GS1100GKZ/GK2	1982	VZ-3002	642-3002
GS1100LT	1980	VZ-3003	642-3003
GSX1100FJ-FP Katana	88-93	VZ-3006	642-3006
GSX-R1100G/H/J/K/L/M/N	86-92	VZ-3006	642-3006







## Kawasaki Z1-900/KZ1000 Point Cover

Right side ignition cover for early model Z1/KZ900 and KZ1000 with point ignition. Kawasaki OEM reference 14027-023-080.

**Made in Japan.** Sold each.

Order No. **900-160**

### Kawasaki

Model	Year
Z1/A/B-900	73-75
KZ900A4/A5	76-77
KZ900B1 LTD	1976
KZ1000A1/A2	77-78
KZ1000B1/B2 LTD	77-78
KZ1000C1/C1A Police	1978
KZ1000D1 Z1R	1978

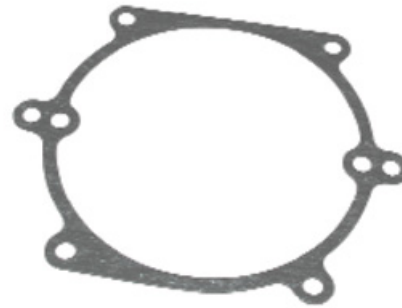

## Inner Kawasaki Point Cover Gasket

Holder cover (inner) gasket. Kawasaki OEM Reference 11061-1129, 11060-1071, 14046-023.

Sold each. **Made in Japan.**

Order No. **642-4001**

### Kawasaki

Model	Year
Z1/A/B-900	73-75
KZ900A4/A5	76-77
KZ900B1 LTD	1976
KZ1000A1/A2	77-78
KZ1000A3/A3A/A4 MKII	79-80
KZ1000B1/B2/B3/B4 LTD	77-80
KZ1000C1/C1A/C2/C3/C4 Police	78-81
KZ1000D1 Z1R	1978
KZ1000D3 Z1R	1980
KZ1000E1/E2 Shaft	79-80
KZ1000G1 Classic LTD	1980
KZ1000J1/J2/J3	81-83
KZ1000K1/K2 LTD	81-82
KZ1000M1/M2 CSR	81-82
KZ1000P1-P22 Police	82-02
KZ1000P24 Police	2005
KZ1000R1/R2 Replica	82-83
KZ1100A1/A2/A3 Shaft	81-83
KZ1100B1/B2 GPz	81-82
KZ1100D1/D2 Spectre	82-83
KZ1100L1 Shaft	1983
ZN1100B Shaft	84-85
ZX1100A1/A2 GPz	83-84



## Kawasaki Z1-900/KZ1000 Stator Cover

Stator cover for early model Z1/KZ900 and KZ1000. Sold each.

Order No. **615-700**

### Kawasaki

Model	Year
Z1/A/B-900	73-75
KZ900A4/A5	76-77
KZ900B1 LTD	1976
KZ1000A1/A2	77-78
KZ1000B1/B2 LTD	77-78
KZ1000C1/C1A Police	1978
KZ1000D1 Z1R	1978



## Sudco Oil Filters

Sudco Oil Filters are Made in Japan by the same manufacturers who supply oil filters to the OEM mfgs. Sudco Oil Filters are made to original manufacturer's specifications for fit, performance and quality. Sold each. **Note:** Oil Filters are listed in the Engine Section on page 372-387.

# Stator Cover Gaskets



## Stator Cover Gaskets (Alternator/Generator)

Made in Japan. Sold each.

### Honda Street

Model	Year	Vesrah Ref	Order No.
CB350F/F1 Super Sport	72-74	VY-1003	<b>640-1003</b>
CB350G	1973	VY-1004	<b>640-1004</b>
CB350K0/K1-K4 Super Sport	68-73	VY-1004	<b>640-1004</b>
CL350K0/K1-K5 Scrambler	68-73	VY-1004	<b>640-1004</b>
SL350K0/K1/K2 Moto Sport	70-72	VY-1004	<b>640-1004</b>
CB360K0	1974	VY-1002	<b>640-1002</b>
CB360T	75-76	VY-1004	<b>640-1004</b>
CB400F Super Sport	75-77	VY-1003	<b>640-1003</b>
CB450D Super Sport 450	1967	VY-1002	<b>640-1002</b>
CB450K0 Super Sport 450	65-68	VY-1002	<b>640-1002</b>
CB450K1-K7 Super Sport 450	68-74	VY-1002	<b>640-1002</b>
CL450 Scrambler 450	1967	VY-1002	<b>640-1002</b>
CL450K1-K6 Scrambler 450	68-74	VY-1002	<b>640-1002</b>
CB500T	75-76	VY-1002	<b>640-1002</b>
NX650	88-89	VK-1070	<b>641-1070</b>
CB750A Automatic	76-78	VY-1001	<b>640-1001</b>
CB750F Super Sport	75-78	VY-1001	<b>640-1001</b>
CB750K0/K1-K5 750 Four	69-75	VY-1001	<b>640-1001</b>
CB750K 750 Four	76-78	VY-1001	<b>640-1001</b>

### Kawasaki Street

EN450A1-A6 LTD 454	85-90	VY-4031	<b>640-4031</b>
EX500A1-A7	87-93	VY-4031	<b>640-4031</b>
KZ550A1/A2/A3/A4	80-83	VY-4014	<b>640-4014</b>
KZ550C1/C2/C3/C4 LTD	80-83	VY-4014	<b>640-4014</b>
KZ550D1 GPz	1981	VY-4014	<b>640-4014</b>
KZ550F1 Spectre	1983	VY-4014	<b>640-4014</b>
KZ550F2 LTD	1984	VY-4014	<b>640-4014</b>
KZ550H1/H2 GPz	82-83	VY-4014	<b>640-4014</b>
KZ550M1 LTD	1983	VY-4014	<b>640-4014</b>
ZX550A1/A2/A3 GPz	84-86	VY-4014	<b>640-4014</b>
KL600B1/B2 KLR600 Dual Sport	85-86	VY-4033	<b>640-4033</b>
ZL600A1/A2 Eliminator	86-87	VY-4028	<b>640-4028</b>
ZL600B2/B3 Eliminator	96-97	VY-4028	<b>640-4028</b>
ZX600A1/A2/A3 Ninja 600R	85-87	VY-4028	<b>640-4028</b>
ZX600B1 Ninja 600RX	1987	VY-4028	<b>640-4028</b>
ZX600C1-C10 Ninja 600R	88-97	VY-4028	<b>640-4028</b>
KL650A1-A19 KLR650 Dual Sport	87-05	VY-4033	<b>640-4033</b>
KZ650B2/B2A/B3	78-79	VY-4017	<b>640-4017</b>
KZ650C2/C3 Custom	78-79	VY-4017	<b>640-4017</b>
KZ650D1/D1A/D2 SR	78-79	VY-4017	<b>640-4017</b>
KZ650E1 LTD	1980	VY-4017	<b>640-4017</b>
KZ650F1	1980	VY-4017	<b>640-4017</b>
KZ650H1/H2/H3 CSR	81-83	VY-4017	<b>640-4017</b>
KZ700A1	1984	VY-4017	<b>640-4017</b>
ZN700A1/A2 LTD	84-85	VY-4017	<b>640-4017</b>
KZ750B1/B2/B3/B4 2-cylinder	76-79	VY-4019	<b>640-4018</b>
KZ750E1/E2/E3	80-82	VY-4017	<b>640-4017</b>
KZ750F1/F2 Spectre & LTD	83-84	VY-4017	<b>640-4017</b>
KZ750G1 LTD 2-cylinder	1980	VY-4018	<b>640-4018</b>
KZ750H1/H2/H3/H4 LTD	80-83	VY-4017	<b>640-4017</b>
KZ750K1/K2 2-cylinder	83-84	VY-4018	<b>640-4018</b>
KZ750L3	1983	VY-4017	<b>640-4017</b>
KZ750M1 CSR 2-cylinder	1983	VY-4018	<b>640-4018</b>
KZ750N1/N2 Spectre	82-83	VY-4017	<b>640-4017</b>
KZ750R1 GPz	1982	VY-4017	<b>640-4017</b>
ZX750A1/A2/A3 GPz	83-85	VY-4017	<b>640-4017</b>
ZX750E1/E2 GPz Turbo	84-85	VY-4017	<b>640-4017</b>

## Kawasaki Street

Model	Year	Vesrah Ref	Order No.
KZ900A4/A5	76-77	VY-4001	<b>640-4001</b>
KZ900B1 LTD	1976	VY-4001	<b>640-4001</b>
Z1/Z1A/Z1B-900	73-75	VY-4001	<b>640-4001</b>
KZ1000A1/A2	77-78	VY-4001	<b>640-4001</b>
KZ1000A3/A3A/A4 MKII	79-80	VY-4001	<b>640-4001</b>
KZ1000B1/B2/B3/B4 LTD	77-80	VY-4001	<b>640-4001</b>
KZ1000C1/C1A/C2/C3/C4 Police	78-81	VY-4001	<b>640-4001</b>
KZ1000D1 Z1R	1978	VY-4001	<b>640-4001</b>
KZ1000D3 Z1R	1980	VY-4001	<b>640-4001</b>
KZ1000E1/E2 Shaft ST	79-80	VY-4001	<b>640-4001</b>
KZ1000G1 Classic LTD	1980	VY-4001	<b>640-4001</b>
KZ1000J1/J2/J3	81-83	VY-4001	<b>640-4001</b>
KZ1000K1/K2 LTD	81-82	VY-4001	<b>640-4001</b>
KZ1000M1/M2 CSR	81-82	VY-4001	<b>640-4001</b>
KZ1000P1-P21 Police	82-02	VY-4001	<b>640-4001</b>
KZ1000R1/R2 Replica	82-83	VY-4001	<b>640-4001</b>
KZ1100A1/A2/A3 Shaft	81-83	VY-4001	<b>640-4001</b>
KZ1100B1/B2 GPz	81-82	VY-4001	<b>640-4001</b>
KZ1100D1/D2 Spectre	82-83	VY-4001	<b>640-4001</b>
KZ1100L1 LTD	1983	VY-4001	<b>640-4001</b>
ZN1100B1/B2 LTD	84-85	VY-4001	<b>640-4001</b>
ZX1100A1/A2 GPz	83-84	VY-4001	<b>640-4001</b>
KZ1300A1/A2/A3/A4	79-82	VY-4027	<b>640-4027</b>
KZ1300B2 Tourer	1980	VY-4027	<b>640-4027</b>
ZN1300 A1-A6 Voyager	83-87	VY-4027	<b>640-4027</b>

## Suzuki Street

GS450ET/EX/EZ/ED	80-83	VY-3002	<b>640-3002</b>
GS450LT/LX/LZ/LD	80-83	VY-3002	<b>640-3002</b>
GS450LF/LG/LH/LJ	85-88	VY-3002	<b>640-3002</b>
GS450ST/SX	81-82	VY-3002	<b>640-3002</b>
GS450TX/TZ	81-82	VY-3002	<b>640-3002</b>
GS450TX/TZ/TXD/TXD	82-83	VY-3002	<b>640-3002</b>
GS550B/C/EC/N/EN	77-79	VY-3003	<b>640-3003</b>
GS550ET	1980	VY-3003	<b>640-3003</b>
GS550ED/ESD	1983	VY-3009	<b>640-3009</b>
GS550ES3/ESE/EF/ESF/ESG	83-86	VY-3009	<b>640-3009</b>
GS550LN/LT/LX/LZ	79-82	VY-3003	<b>640-3003</b>
GS550LD	1983	VY-3009	<b>640-3009</b>
GS550LF/LG	85-86	VY-3009	<b>640-3009</b>
GS550MZ Katana	1982	VY-3003	<b>640-3003</b>
GS550TX	1981	VY-3003	<b>640-3003</b>
GS650EX/EZ	81-82	VY-3003	<b>640-3003</b>
LS650FG/FH Savage	86-87	VY-3035	<b>640-3035</b>
LS650PG/PH/PJ Savage	86-88	VY-3035	<b>640-3035</b>
GS700EF/ESF	1985	VY-3007	<b>640-3007</b>
VS700GLFG/GLFH Intruder	86-87	VY-3045	<b>640-3045</b>
VS700GLPG/GLPH Intruder	86-87	VY-3045	<b>640-3045</b>
VS700GLEFG/GLEFH Intruder	86-87	VY-3045	<b>640-3045</b>
VS700GLEPG/GLEPH Intruder	86-87	VY-3045	<b>640-3045</b>
GS750B/C/EC/N/EN	77-79	VY-3004	<b>640-3004</b>
GS750ET/EX/EZ	80-82	VY-3005	<b>640-3005</b>
GS750ED/ESD	1983	VY-3007	<b>640-3007</b>
GS750LN	1979	VY-3004	<b>640-3004</b>
GS750LT/LX	80-81	VY-3005	<b>640-3005</b>
GS750TZ/TD	82-83	VY-3005	<b>640-3005</b>
GS750SD Katana	1983	VY-3005	<b>640-3005</b>
VS750GLPJ/K/L/M	88-91	VY-3045	<b>640-3045</b>
GS850GN/GT/GX/GZ/GD	79-83	VY-3004	<b>640-3004</b>
GS850GLT/GLX/GLZ/GLD	80-83	VY-3004	<b>640-3004</b>

# Stator Cover Gaskets. Oil Pan Gasket & Oil Level Gauge

VINTAGE  
INTAKE  
ENGINE  
SUSPENSION  
CONTROL  
ELECTRICAL  
CHEMICAL  
TOOLS  
WATERCRAFT

## Suzuki Street

Model	Year	Vesrah Ref	Order No.
GS1000C/EC/N/EN/ET	78-80	VY-3004	<b>640-3004</b>
GS1000GT/GX	80-81	VY-3004	<b>640-3004</b>
GS1000GLT/GLX	80-81	VY-3004	<b>640-3004</b>
GS1000LN	1979	VY-3004	<b>640-3004</b>
GS1000SN/ST	79-80	VY-3004	<b>640-3004</b>
GS1000SZ Katana	1983	VY-3005	<b>640-3005</b>
GS1100ET/EX/EZ	80-82	VY-3005	<b>640-3005</b>
GS1100ED/ESD	1983	VY-3005	<b>640-3005</b>
GS1100GZ/GLZ/GD/GLD	82-83	VY-3004	<b>640-3004</b>
GS1100GKZ/GK2/GKD/GKE	82-84	VY-3004	<b>640-3004</b>
GS1100LT	1980	VY-3005	<b>640-3005</b>
GS1100SD Katana	1983	VY-3005	<b>640-3005</b>
GS1150ES3/ESE/EF/ESF/EF2	83-85	VY-3005	<b>640-3005</b>
GS1150EG/ESG	1986	VY-3005	<b>640-3005</b>
VS1400GLPH-GLPY Intruder	87-00	VY-3046	<b>640-3046</b>

## Yamaha Street

Model	Year	Vesrah Ref	Order No.
XT250L/LC	1984	VK-2017	<b>641-2017</b>
XT350N/NC-M/MC Dual Sport	85-00	VK-2017	<b>641-2017</b>
XT550J/K Dual Sport	82-83	VK-2011	<b>641-2011</b>
XT600L/LC-W/WC Dual Sport	84-89	VK-2011	<b>641-2011</b>
FZR400U/SUC-A/SAC	88-90	VK-2032	<b>641-2032</b>
SRX600S/SC	1986	VK-2011	<b>641-2011</b>
XV700L/LC/N/NC Virago	84-85	VK-2021	<b>641-2021</b>
XV700CS/CSC/CT/CTC Virago	86-87	VK-2021	<b>641-2021</b>
XV700SS/SSC Virago	1986	VK-2021	<b>641-2021</b>
XV750H/J/K Virago	81-83	VK-2021	<b>641-2021</b>
XV750MK Midnight Virago	1983	VK-2021	<b>641-2021</b>
XV750U/UC-G/GC Virago	88-95	VK-2021	<b>641-2021</b>
XV920J/K Virago	82-83	VK-2021	<b>641-2021</b>
XV920MK Midnight Virago	1983	VK-2021	<b>641-2021</b>
XV920RH/RJ	81-82	VK-2021	<b>641-2021</b>
XV1000L/LC/N/NC Virago	84-85	VK-2021	<b>641-2021</b>
XV1100S/SC-L/LC Virago	86-99	VK-2021	<b>641-2021</b>

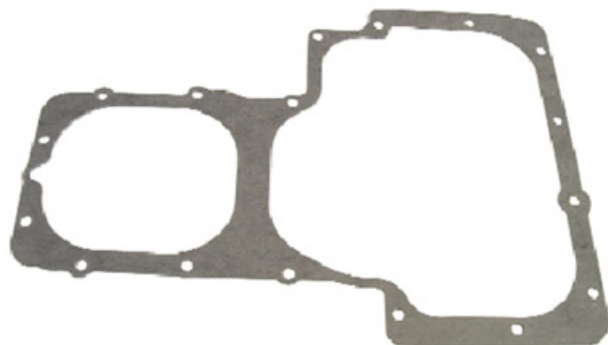

## Oil Pan Gasket

Sold each. **Made in Japan.**

OEM Reference 11060-1074 Order No. **646-4001**



## Oil Level Gauge

Oil sight gauge for Kawasaki Z1/ KZ1000 models.

Sold each. **Made in Japan.**

OEM Reference 52015-004 Order No. **950-265**

## Kawasaki

Model	Year
Z1/Z1A/Z1B-900	73-75
KZ900A4/A5	76-77
KZ900B1 LTD	1976
KZ1000A1/A2	77-78
KZ1000A3/A3A/A4 MKII	79-80
KZ1000B1/B2/B3/B4 LTD	77-80
KZ1000C1/C1A/C2/C3/C4	78-81
KZ1000D1 Z1R	1978
KZ1000D3 Z1R	1980
KZ1000E1/E2 Shaft ST	79-80
KZ1000G1 Classic LTD	1980
KZ1000J1/J2/J3	81-83
KZ1000K1/K2 LTD	81-82
KZ1000M1/M2 CSR	81-82
KZ1000P1-P21 Police	82-02
KZ1000R1/R2 Replica	82-83
KZ1100A1/A2/A3 Shaft	81-83
KZ1100B1/B2 GPz	81-82
KZ1100D1/D2 Spectre	82-83
KZ1100L1 LTD	1983
ZN1100B1/B2 LTD	84-85
ZX1100A1/A2 GPz	83-84

## Kawasaki

Model	Year
KZ650B1/B2/B2A/B3	77-79
KZ650D1/D1A/D2 SR	78-79
KZ750B1/B2/B3/B4 2-cylinder	75-79
KZ750G1 LTD 2-cylinder	1980
Z1/A/B-900	73-75
KZ900A4/A5	76-77
KZ900B1 LTD	1976
KZ1000A1/A2	77-78
KZ1000A3/A3A/A4 MKII	79-80
KZ1000B1/B2/B3/B4 LTD	77-80
KZ1000C1/C1A-C4 Police	78-81
KZ1000D1 Z1R	1978
KZ1000D3 Z1R	1980
KZ1000E1/E2 Shaft ST	79-80
KZ1000G1 LTD Classic	1980
KZ1300A1/A2 up to engine no. 009426	79-80



## RK Drive Chain

Available sizes are O-ring 530XS0/630S0.  
RK Chain is listed in engine section.

Links	O-Ring 530XS0	O-Ring GR530S0 "Gold"	O-Ring 630S0
1	_____	_____	_____
80	<a href="#">325-001</a>	_____	<a href="#">326-001</a>
82	<a href="#">325-002</a>	_____	<a href="#">326-002</a>
84	<a href="#">325-003</a>	_____	<a href="#">326-003</a>
86	<a href="#">325-004</a>	_____	<a href="#">326-004</a>
88	<a href="#">325-005</a>	_____	<a href="#">326-005</a>
90	<a href="#">325-006</a>	_____	<a href="#">326-006</a>
92	<a href="#">325-007</a>	_____	<a href="#">326-007</a>
94	<a href="#">325-008</a>	_____	<a href="#">326-008</a>
96	<a href="#">325-009</a>	_____	<a href="#">326-009</a>
98	<a href="#">325-010</a>	_____	<a href="#">326-010</a>
100	<a href="#">325-011</a>	_____	<a href="#">326-011</a>
102	<a href="#">325-012</a>	_____	<a href="#">326-012</a>
104	<a href="#">325-013</a>	_____	<a href="#">326-013</a>
106	<a href="#">325-014</a>	_____	<a href="#">326-014</a>
108	<a href="#">325-015</a>	_____	<a href="#">326-015</a>
110	<a href="#">325-016</a>	_____	<a href="#">326-016</a>
112	<a href="#">325-017</a>	_____	<a href="#">326-017</a>
114	<a href="#">325-018</a>	_____	<a href="#">326-018</a>
116	<a href="#">325-019</a>	_____	<a href="#">326-019</a>
118	<a href="#">325-020</a>	_____	<a href="#">326-020</a>
120	<a href="#">325-021</a>	<a href="#">329-021</a>	<a href="#">326-021</a>
130	_____	_____	_____
Conn. Links	<a href="#">325-099</a>	_____	<a href="#">326-099</a>
Rivet Links	<a href="#">325-098</a>	<a href="#">329-026</a>	<a href="#">326-098</a>

## Sunstar Steel Sprockets

OEM replacements for applications listed. Sold each.

### Honda

Model	Year	Stock	Counter	Stock	Rear
CB400F Super Sport	75-77	17T	_____	44T	<a href="#">330-196</a>
CB750K0	1969	18T	<a href="#">33250718</a>	45T	<a href="#">330-036</a>
CB750K1/K2/K3		17T	<a href="#">33250717</a>	48T	<a href="#">330-016</a>
CB900F Super Sport	80-82	17T	<a href="#">33251217</a>	44T	<a href="#">330-072</a>
CBX	80-82	_____	_____	44T	<a href="#">330-072</a>
CB1100F Super Sport	1983	_____	_____	44T	<a href="#">330-072</a>

### Kawasaki

S3/A-400	74-75	_____	_____	41T	_____
KH400A	76-78	_____	_____	41T	_____
H1B/C/D/E/F-500	71-75	_____	_____	45T	<a href="#">330-604</a>
KH500A8 (2-stroke triple)	1976	_____	_____	45T	<a href="#">330-604</a>
Z1/A/B-900	73-75	15T	<a href="#">33260515</a>	35T	<a href="#">330-622</a>
KZ1000A3/A3A/A4 MKII	79-80	15T	<a href="#">33260515</a>	35T	<a href="#">330-616</a>
KZ1000D1 Z1R	1978	15T	<a href="#">33260515</a>	33T	<a href="#">330-612</a>
KZ1000D1 Z1R	1980	15T	<a href="#">33260515</a>	35T	<a href="#">330-616</a>
KZ1000J1/J2	81-82	15T	<a href="#">33260515</a>	41T	<a href="#">330-643</a>
KZ1000R1/R2 Replica	82-83	15T	<a href="#">33260515</a>	41T	<a href="#">330-643</a>
KZ1100B1 GPz	1981	15T	<a href="#">33260515</a>	41T	<a href="#">330-643</a>
KZ1100B2 GPz	1982	15T	<a href="#">33260515</a>	42T	_____



## Master Link Clip Pliers

Designed to simplify installation and removal of clip-type master links, one tip is shorter and notched to be placed on the pin which allows the longer end to push the clip.

Order No. [950-759](#)



## Kawasaki Chain Adjuster Bolt & Nut

Sold as set of 2.

Description	Part No.
8mm	<a href="#">901-305</a>
10mm	<a href="#">901-306</a>



900-213

## Fork Tubes

Fork Tubes are sold in pairs. Replacement Fork Seals listed after Fork Tube.

### Honda

Model	Year	Fork Tube Order No.	Fork Seals (pr)
CB77 Super Hawk 305	61-68	900-200	_____
CL77 Scrambler 305	65-68	900-201	_____
CB400F Super Sport	75-77	900-203	516-1015
CB750		900-202	_____

### Kawasaki

H1/A/C-500 Mach III	69-72	900-211	516-1016
H1B-500 2-stroke triple	1972	900-212	516-1025
H1D/E/F-500 2-stroke triple	73-75	900-212	516-1025
KH500A 2-stroke triple	1976	900-212	516-1025
H2/A/B/C-750 Mach IV	72-75	900-212	516-1025
Z1/A/B-900	73-75	900-213	516-1025
KZ900A4/A5	76-77	900-213	516-1025
KZ900B1 LTD	1976	900-213	516-1025
KZ1000A1	1977	900-213	516-1025



## Yamaha DT1-250 Fork Tube Piston

For early model DT1-250 front forks. Sold in pairs.

Order No. 900-285



## Steering Stem Bearing Kits

Quality bearing kits sourced from **Japan** and made to OEM specifications. Kits with an \* (**asterisk**) are an upgrade from stock ball bearing/race to tapered bearing for improved handling and longer life. All other kits are replacements for original tapered bearings.

Made in Japan. Model applications are listed on page 426-433.



## K&S Fork Seal Kits & Dust Seal Kits

Fork Seals and Dust Seals sold in kits. (pairs)

Model applications are listed on page 410-423



## Fork Dust Boot (Dust Shield) **NEW**

Replaces Kawasaki OEM 44010-032. Sold in pair. Available for the the following Kawasaki models.

Order No. 516-010

### Kawasaki Street

Model	Year
H1D/H1E/H1F-500	73-75
KH500A8	1976
KZ650B1/B2/B2A/B3	77-79
KZ650C1/C2/C3 Custom	77-79
KZ650D1/D1A/D2 SR	78-79
KZ650E1 LTD	1980
KZ650F1	1980
KZ750B1/B2/B3/B4 2-cyl.	77-79
KZ750G1 LTD 2-cylinder	1980
KZ900A4/A5	76-77
KZ900B1 LTD	1976
KZ1000A2/A2A	1978
KZ1000A3/A3A/A4 MKII	79-80
KZ1000B1/B2/B3/B4 LTD	77-80
KZ1000D1 Z1R	1978
KZ1000D3 Z1R	1980
KZ1000G1 LTD Classic	1980

### Kawasaki Offroad

KXT250A1/A2 Tecate 3	84-85
KX250/A/A3	74-76
KX250A4/A5	78-79
KX400/A2	75-76

# Brake Pads & Brake Shoes



Kawasaki H1-500 rear 611-420



## Vesrah Brake Pads & Brake Shoes

Sold in sets. For a complete listing of vintage applications not shown, see **Vesrah Brake Pad & Brake Shoes** in control section.

Order per qt needed. Some models listed require qt 2 sets.

**Made in Japan.**

**610 = Kevlar Brake Pads**

**611 = Kevlar Brake Shoes**

**NS= Sintered Pads/ Sintered Shoes**

### Honda

Model	Year	Front	Rear
CA175 Touring (CD175)	68-69	611-135NS	_____
CA175K3 Touring (CD175)	69-70	611-135NS	_____
CB72 Hawk 250	61-66	611-117	611-117
CL72 Scrambler 250	62-65	_____	611-117
CB77 Super Hawk 305	61-68	611-117	611-117
CB350F/F1 Super Sport	72-74	610-102	611-127
CB400F Super Sport	75-77	610-102	611-127
CB450K0 Super Sport	65-68	611-117	_____
CB450K1/K2 Super Sport	68-69	611-117	_____
CL450K1-K6 Scrambler	68-74	611-117	_____
CB500K0/K1/K2	71-73	610-102	611-128
CB500T (2-cyl.)	75-76	610-102	611-128
CX500	78-79	_____	611-133
CX500C Custom	79-80	_____	611-133
CX500C Custom	1981	610-112	611-133
CX500C Custom	1982	610-123	611-133
CX500D Deluxe	79-80	_____	611-133
CX500D Deluxe	1981	610-112	611-133
CX500TC Turbo	1982	610-123	610-123
FT500 Ascot	82-83	610-123	610-123
GL500 Silver Wing	81-82	610-123	611-133
GL500I Silver Wing Interstate	81-82	610-123/2	611-133
CB550F Super Sport	75-77	610-102	611-128
CB550K0/K1	74-75	610-102	611-128
CB550K	76-78	610-102	611-128
CB550SC Nighthawk	1983	610-123	611-132
CB750A Automatic	76-78	610-102	611-129
CB750C Custom	80-81	_____	611-129
CB750C Custom	1982	610-123/2	611-129
CB750F Super Sport	75-76	610-102	610-108
CB750F Super Sport	77-79	610-112	610-112
CB750K0/K1/K2/K3/K4/K5	69-75	610-101	611-129
CB750K	1976	610-101	611-129
CB750K	77-78	610-102	611-129
CB750K	79-81	_____	611-129
CB750K	1982	610-123	611-129
CB750L LTD	1979	_____	611-129
CB750SC Nighthawk	82-83	610-123/2	611-129
CB900C Custom	1980	610-112	_____
CB900C Custom	1981	610-123/2	_____
CB900C Custom	1982	610-123/2	610-123
CB900F Super Sport	81-82	610-123/2	610-123
CB1000C Custom	1983	610-123/2	610-123
GL1000 Goldwing	75-77	_____	610-108
GL1000 Goldwing	78-79	610-112	610-108

### Honda

Model	Year	Front	Rear
GL1000L Goldwing LTD	1976	_____	610-108
CBX1000	1979	610-112	610-112
CBX1000	1980	610-112	_____
CBX1000	81-82	610-123/2	610-123
CB1100F Super Sport	1983	610-123/2	610-123
GL1100 Goldwing	80-81	610-112	_____
GL1100 Goldwing	82-83	610-123/2	610-123
GL1100A Goldwing Aspencade	82-83	610-123/2	610-123
GL1100I Goldwing Interstate	80-81	610-112	_____
GL1100I Goldwing Interstate	82-83	610-123/2	610-123
GL1200 Goldwing	1984	610-123/3	610-123/3
GL1200A Goldwing Aspencade	84-87	610-123/3	610-123/3
GL1200I Goldwing Interstate	84-87	610-123/3	610-123/3
GL1200L Goldwing LTD	1985	610-123/3	610-123/3
GL1200SEi Goldwing SEi	1986	610-123/3	610-123/3

### Kawasaki

KH250A6 2-Stroke Triple	1976	_____	611-404
S1A/S1B/S1C-250 2-Stroke	73-75	_____	611-404
S2-350 2-Stroke Triple	1972	_____	611-404
S2-350 2-Stroke Triple	1973	610-301	611-404
KH400A3/A4/A5 2-Stroke Triple	76-78	610-414	611-404
S3/A-400 2-Stroke Triple	74-75	610-301	611-404
H1/A/C-500 Mach III	69-72	_____	611-420
H1B-500 (disc brake model)	1972	610-301	611-420
H1D/H1E/H1F-500	73-75	610-301	_____
KH500A8	1976	610-414	_____
KZ550A1	1980	610-414	611-412
KZ550A2/A3/A4	81-83	610-420/2	611-412
KZ550C1/C2/C3/C4 LTD	80-83	610-420/2	611-412
KZ550D1 GPz	1981	610-420	610-420/2
KZ550F1 Spectre	1983	610-420/2	611-412
KZ550F2 LTD	1984	610-420/2	611-412
KZ550H1/H2 GPz	82-83	610-420	610-420/2
KZ550M1 LTD	1983	610-420/2	611-412
ZX550A1/A2/A3 GPz	84-86	610-426	610-426
KZ650B1/B2/B2A/B3	77-79	610-414	611-412
KZ650C1/C2/C3 Custom	77-79	610-414	611-412
KZ650D1/D1A/D2 SR	78-79	610-414	610-306
KZ650E1 LTD	1980	610-414	611-412
KZ650F1	1980	610-414	611-412
KZ650H1/H2/H3 CSR	81-83	610-420/2	611-412
W1-650	66-69	_____	611-420
W1SS-650	68-69	_____	611-420
W2SS-650 Commander	67-70	_____	611-420
W2TT-650 Commander	68-70	_____	611-420
KZ700A1	1984	610-420	610-420/2
VN700A1 Vulcan	1985	610-426	611-412
ZN700A1/A2 LTD	84-85	610-426	610-426
H2/A/B/C-750 Mach IV	72-75	610-301	611-405
KZ750B1/B2/B3/B4 (2-cyl.)	76-79	610-414	611-412
KZ750E1/E2/E3	80-82	610-420	610-420/2
KZ750F1 LTD	1983	610-420	610-420/2

## Kawasaki

Model	Year	Front	Rear
KZ750G1 LTD (2-cyl.)	1980	610-414	611-412
KZ750H1/H2/H3/H4 LTD	80-83	610-420	610-420/2
KZ750K1/K2 LTD (2-cyl.)	83-84	610-414	611-412
KZ750L3	1983	610-420	610-420/2
KZ750M1 CSR (2-cyl.)	1982	610-420/2	610-412
KZ750N1/N2 Spectre	82-83	610-420	610-420/2
KZ750R1 GPz	1982	610-420	610-420/2
KZ900A4/A5	76-77	610-414	611-405
KZ900B1 LTD	1976	610-414	610-412
Z1/A/B-900	73-75	610-301	611-405
KZ1000A1/A2	77-78	610-414	610-412
KZ1000A3/A3A/A4 MKII	79-80	610-414	610-306/2
KZ1000B1/B2 LTD	77-78	610-414	610-412
KZ1000B3/B4 LTD	79-80	610-414	610-306/2
KZ1000C1/C1A	1978	610-414	610-306
KZ1000C2/C3/C4 Police	79-81	610-414	610-306/2
KZ1000D1 Z1R	1978	610-414	610-306
KZ1000D1 Z1R	1980	610-414	610-306/2
KZ1000E1/E2 Shaft ST	79-80	610-414	610-306/2
KZ1000G1 LTD Classic	1980	610-414	610-306/2
KZ1000J1/J2/J3	81-83	610-420	610-420/2
KZ1000K1/K2 LTD	81-82	610-420	610-420/2
KZ1000M1/M2 CSR	81-82	610-420	610-420/2
KZ1000R1/R2 Replica	82-83	610-420	610-420/2
KZ1100A1/A2/A3 Shaft	81-83	610-420	610-420/2
KZ1100B1/B2 GPz	81-82	610-420	610-420/2
KZ1100D1/D2 Spectre	82-83	610-420	610-420/2
KZ1100L1 LTD	1983	610-420	610-420/2
KZ1300A1/A2/A3/A4	79-82	610-423	610-306/2

## Suzuki

GT185L/M/A/B Adventurer	74-77	610-301	611-302
GN250Z/D, GN250F, GN250J	82-88	—	611-302
GT250K Hustler	1973	—	611-305
GT250L/M/A/B Hustler	74-77	610-301	611-305
T3501/2/R/J	69-72	611-304	611-305
GT380J Sebring	1972	611-304	611-305
GT380K/L/M/A/B (Tokico caliper)	73-77	610-301	611-305
GT380B (Asco caliper)	1977	610-320	611-305
GS400B/C (w/front disc)	77-78	610-318	611-305
GS400XB/XC (w/front drum)	77-78	—	611-305
GS425N/EN	1979	610-318	611-308
GT500A/B Titan	76-77	610-301	611-305
RE5M/RE5MA Rotary	75-76	610-301	611-306
T5001/2/3	68-70	—	611-305
T500R/J/K/L/M Titan	71-75	—	611-305
GT550J Indy	1972	—	611-305
GT550K/L/M Indy	73-75	610-301	611-305
GT550A/B (Tokico caliper)	76-77	610-301	611-307
GT550B (Asco caliper)	1977	610-320	611-307
GS750B/C/EC/N/EN	77-79	610-318	610-306
GT750K/L/M/A/B Lemans	73-77	610-301	611-306
GS850GN	1979	610-318	610-306
GS850GT/GLT-GD/GLD	80-83	610-322	610-306
GS1000C/EC/N/EN/ET	78-80	—	611-306
GS1000GT/GLT/GX/GLX	80-81	610-322	610-306
GS1000LN/SN	1979	—	611-306
GS1000ST	1980	610-324	610-306
GS1000SZ Katana	1982	610-324	610-306
GS1100ET-ESD	80-83	610-324	610-306
GS1100GZ-GLD	82-83	610-322	610-306
GS1100GKZ-GKD	82-84	610-322	610-306
GS1100LT	1980	610-324	610-306
GS1100SD Katana	1983	610-324	610-306
GS1150ES3-ESG	83-86	610-331	610-331

## Yamaha

Model	Year	Front	Rear
RD200A/B	74-75	611-206	611-228
RD200C	1976	—	611-228
SR250G/H/TH/J Exciter	80-82	611-220	611-223
RD350A/B	73-75	610-204	611-225
RZ350L/LC/N/NC	84-85	610-235	610-236
XS360C/D/2D	76-77	610-205	611-231
RD400C/D/E	76-78	610-204	610-204
RD400F	1979	610-215	610-215
XS400D/E/F	77-79	610-205	610-205
XS400E/2F	78-79	611-206	611-231
XS400G/H Special	80-81	611-206	611-231
XS400J/K Maxim	82-83	610-235	611-231
XS400R/J/RK Seca	82-83	610-235	611-231
XS400SG/SH Special	80-81	610-215	611-231
XS400SJ Special	1982	611-206	611-231
SR500E/F	78-79	610-205	610-205
SR500G/H	80-81	610-205	611-228
TX500A & XS500B	73-75	610-204	611-227
XS500C/D/E	76-78	610-205	610-205
XJ550H/J/K Maxim	81-83	610-228	611-227
XJ550RH/RJ/RK Seca	81-83	610-228	611-231
XZ550R/J/RK Vision	82-83	610-235	611-227
FJ600L/LC/N/NC	84-85	610-236	610-236
SRX600S/SC	1986	610-240	610-240
YX600 Radian	86-90	610-236	611-227
XJ650G/H/J/K Maxim	80-83	610-216	611-227
XJ650LH Midnight Maxim	1981	610-216	611-227
XJ650LJ/LK Turbo	82-83	610-216	611-227
XJ650RJ Seca	1982	610-205	611-230
XS1/XS1B-650	70-71	—	611-225
XS2-650	1972	610-204	611-225
TX650A	73-74	610-204	611-225
XS650B/C	75-76	610-204	611-225
XS650D/E/F/2F	77-79	610-205	611-225
XS650G/H Special II	80-81	610-205	611-225
XS650SE/SF/SG Special	78-80	610-205	610-205
XS650SH Special	1981	610-205	611-225
XS650SJ/SK Heritage Special	82-83	610-205	611-225
FZ700T/TC	1987	610-236	610-236
FZX700 Fazer	86-87	610-236	610-236
XJ700 Maxim & Maxim X	85-86	610-236	611-230
XV700CS/CSC/CT/CTC	86-87	610-236	611-230
XV700L/LC-T/TC Virago	84-87	610-236	611-230
FZ750N/S/SC & FZ750U/UC	85-86, 1988	610-236	610-236
FZR750RT/RU	87-88	610-242/2	610-236
TX750A	73-74	610-204	611-230
XJ750J/K/MK Maxim	82-83	610-235	611-230
XJ750RH/RJ/RK Seca	81-82/3	610-228	611-230
XS750D/2D/E/F	77-79	610-205	610-205
XS750SE/SF Special	78-79	610-216-L	610-205
		610-215-R	—
XV750H/J/K/MK Virago	81-83	610-216	611-227
XS850G/H	80-81	610-205	610-205
XS850LG/LH Midnight Special	80-81	610-216-L	610-215
		610-215-R	—
XS850SG/SH Special	80-81	610-216-L	610-215
		610-215-R	—
XJ900RK Seca	1983	610-236	610-236
XV920J Virago	1982	610-228	611-230
XV920K/MK Virago	1983	610-216	611-230
XV920RH/RJ	81-82	610-205	611-230
XS1100E/F/G/H	78-81	610-205	610-205
XS1100LG Midnight Special	1980	610-216-L	610-205
		610-215-R	—

# Master Cylinder Rebuild Kits & Diaphragms



850-100



850-300



850-301

## Master Cylinder Rebuild Kits

Complete kits contain all necessary components to rebuild one OEM master cylinder. **Made in Japan.**

### Honda Street

Model	Year	Front	Rear
CB400F Super Sport	75-77	850-103	—
CB750F Super Sport	75-76	850-103	—
CB750K0/K1/K2/K3/K4/K5/K	69-76	850-103	—

### Kawasaki Street

Model	Year	Front	Rear
S2/S2A-350 Match II 2-stroke triple	72-73	850-100	—
KH40A3/A4 2-stroke triple	76-77	850-100	—
KZ4000A1-A2	77-78	850-100	—
KZ400/D/D3/D4	74-77	850-100	—
S3/S3A-400 2-stroke triple	74-75	850-100	—
H1B-500 2-stroke triple	1972	850-100	—
H1D/H1E-500 2-stroke triple	73-74	850-100	—
H1F-500 2-stroke triple	1975	850-100	—
KH500A8 2-stroke triple	1976	850-100	—
KZ650B1	1977	850-100	—
H2/H2A/H2B/H2C-750 Mach V	72-75	850-100	—
KZ750B1/B2 2-cylinder	76-77	850-100	—
KZ900A4/A5	76-77	850-100	—
Z1/Z1A/Z1B-900	73-75	850-100	—
KZ1000A1	1977	850-100	—

### Yamaha Street

Model	Year	Front	Rear
RZ350L/N/NC/NCII	84-85	850-133	850-144
XZ550RK Vision	1983	850-133	—
XJ650LJ/LK Seca Turbo	82-83	850-133	—
XJ650RJ Seca	1982	850-133	—
XS6502F	1979	850-106	—
XS650SE/SF	78-79	850-106	—
XS650G/H	80-81	850-106	—
XS650SH	1981	850-106	—
XS650SK/SJ Heritage Special	82-83	850-106	—
XJ700N/NC/S/SC Maxim	85-86	850-133	—
XJ700XN/XNC/XS/XSC Maxim	85-86	850-133	—
XV700L/LC/N/NC Virago	84-85	850-133	—
XV700CS/CSC/CT/CTC Virago	86-87	850-133	—
XV700SS/SSC Virago	1986	850-133	—
XJ750J/K Maxim	82-83	850-133	—
XJ750MK Midnight Maxim	1983	850-133	—
XS750E/F	78-79	850-106	—
XS750SE/SF Special	78-79	850-106	—
XV750U/UC-H/HC Virago	88-96	850-133	—
XV750H1/H1C/J1/J1C Virago	96-97	850-133	—
XS850G/H	80-81	850-106	—
XS850LG/LH Midnight Special	80-81	850-106	—
XS850SG/SH Special	80-81	850-106	—
XJ900RK Seca	1983	850-133	—
XV920J Virago	1982	850-133	—
XV920RH/RJ	81-82	850-133	—
XS1100E/F/G/H	78-81	850-106	—
XS1100LG Midnight Special	1979	850-106	—
XS1100SF/SG/SH Special	79-81	850-106	—

## Master Cylinder Diaphragms **NEW**

Available for early vintage model Kawasaki master cylinders. Sold each. **Made in Japan.**

### Kawasaki Street

Model	Year	Front	Rear
S2A-350 Mach II 2-stroke triple	1973	850-300	—
KH400A3/A4 2-stroke triple	76-77	850-300	—
KH400A5 2-stroke triple	1978	850-301	—
KZ400A1/A2	77-78	850-300	—
KZ400B1/B2	74-77	850-301	—
KZ400/D/D3/D4	74-77	850-300	—
H1B-500 2-stroke triple	1972	850-300	—
H1D/H1E/H1500 2-stroke triple	73-75	850-300	—
KH500A8 2-stroke triple	1976	850-300	—
KZ650B1	1977	850-300	—
KZ650B2/B2A/B3	78-79	850-301	—
KZ650C1 Custom	1977	850-300	850-300
KZ650C2/C3 Custom	78-79	850-301	850-300
KZ650D1/D1A/D2 SR	78-79	850-301	850-300
H2/H2A/H2B/H2C-750 Mach V	72-75	850-300	—
KZ750B1/B2 2-cylinder	76-77	850-300	850-300
KZ750B3/B4 2-cylinder	78-79	850-301	850-300
Z1/Z1A/Z1B-900	73-75	850-300	—
KZ900A4/A5	76-77	850-300	—
KZ900B1	1976	850-300	850-300
KZ1000A1	1977	850-300	850-300
KZ1000A2/A2A	1978	850-301	850-300
KZ1000A3A3A/A4 MKII	79-80	850-301	850-300
KZ1000B1 LTD	1977	850-300	850-300
KZ1000B2/B3 LTD	78-79	850-301	850-300
KZ1000B4 LTD	1980	850-301	—
KZ1000C1/C1A/C2/C3 Police	78-80	850-301	850-300
KZ1000D1 Z1R	1978	—	850-300
KZ1000E1 Shaft ST	1979	—	850-300



## Master Cylinder Snap-Ring Pliers

Allows removal of internal snap rings used in hydraulic master cylinders. Replaces Honda 07914-SA50001. Can be used to remove and replace small to medium internal snap rings up to 50mm deep, including those used for transmission gear locating, bearing retention, and oil seal retention. Applicable to some fork seal retaining rings.

Order No. **950-775**





603-004



603-003

## Sudco Brake Caliper Pistons

Replacement brake caliper pistons for Honda. Sold each. **Made in Japan.** Qt. listed is for all calipers on model. Order per Sudco part number and qt needed for replacement.

### Honda

45107-MA3-006 Front Piston Order No. 603-004	Year	Qt
CB400T Hawk	1981	2
CM400C Custom	1981	2
CB450SC Nighthawk	1986	2
CMX450C Rebel	86-87	2
CX500C Custom	1982	2
CX500TC Turbo	1982	4
FT500 Ascot	82-83	2
GB500	89-90	2
GL500 Silverwing	81-82	2
GL500I Silverwing Interstate	81-82	4
VF500F Interceptor	84-86	4
XL600V Transalp	89-90	2
CB650SC Nighthawk	83-85	4
GL650 Silver Wing	1983	4
GL650I Silver Wing Interstate	1983	4
VF700C Magna	84-86	4
VF700C Magna	1987	2
VF700S Sabre	84-85	4
CB750C Custom	1982	2
CB750F Super Sport	81-82	4
CB750SC Nighthawk	82-83	4
VF750C V45 Magna	82-83	4
VF750C V45 Magna	1988	2
VF750S Sabre	82-83	4
VT800C Shadow	1988	2
CB900C Custom	1982	4
CB900F Super Sport	81-82	4
CB1000C Custom	1983	4
CBX	81-82	4
CB1100F Super Sport	1983	4
GL1100 Goldwing	1982	4
GL1100A Goldwing Aspencade	1982	4
GL1100I Goldwing Interstate	1982	4
VT1100C Shadow	85-86	4
VT1100C Shadow	87-90	2
VT1100C Shadow	92-93	2

### Honda

43107-MA7-006 Front Piston Order No. 603-003	Year	Qt.
VF500 C Magna	84-85	2
VT500C Shadow	83-86	2
VT500FT Ascot	83-84	2
CB550SC Nighthawk	1983	2
CX650C Custom	1983	2
CX650T Turbo	1983	4
CB700SC Nighthawk	84-86	4
VF700F Interceptor	84-85	4
VT700C Shadow	86-87	2
VF750F Interceptor	83-84	4
VF1000F Interceptor	1984	4
VF1000	86-87	4
VF1100C V65 Magna	83-86	4
VF1100S V65 Sabre	84-85	4

45107-415-006 Front Piston Order No. 603-001	Year	Qt
CX500	78-79	1
CX500C Custom	79-81	1
CX500D Deluxe	79-81	1
CB900C Custom	1981	2
CBX	79-80	2
GL1000 Goldwing	1979	2
GL1100 Goldwing	80-81	2
GL1100I Goldwing Interstate	80-81	2

45107-410-006 Front Piston Order No. 603-002	Year	Qt
CB750F Super Sport	77-78	2
CB750F Super Sport	79-80	2
CB900C Custom (2)	1980	2
GL1000 Goldwing	1978	2

43205-371-006 Rear Piston Order No. 603-005	Year	Qt
CB750F Super Sport	75-76	1
GL1000 Goldwing	75-77	1
GL1000L Goldwing LTD	1976	1



## Chrome Rear Shocks for H1-500 & H2-750

Reproductions of the original shocks fit Kawasaki H2-750 1972-75, and H1-500 1969-76 models, are all chrome with a gray plastic sleeve inside the spring to protect the damper rod. Extended length is 325mm from eye to eye. Top bush is 14mm, bottom bush 10mm. Sold in pairs.

### Kawasaki

Model	Year	Description	Order No.
H1-500	69-76	Chrome Shocks	500-602
H2-750	72-75	Chrome Shocks	500-602



900-175

## Chrome Rear Shocks for Z1/KZ900 & KZ1000

Reproduction of the original, early Z1-900 shocks and KZ900/1000. Chrome shock covers with reflectors and without. Sold in pairs.

### Kawasaki

Model	Year	Description	Order No.
Z1/A/B-900	73-75	Chrome Shocks with reflector	900-175
KZ900A4/A5	76-77	Chrome Shocks no reflector	500-600
KZ1000		Chrome Shocks no reflector	500-600

# Brake & Shift Parts, Fender Washers

VINTAGE  
INTAKE  
ENGINE  
SUSPENSION  
CONTROL  
ELECTRICAL  
CHEMICAL  
TOOLS  
WATERCRAFT



## Z1/KZ900 Brake Pedal

Fits Z1/A/B-900 and KZ900. Brake Petal only.

Sold each.

Order No. **951-070**



## Z1/KZ900 Brake Rod

Reproduction rear brake rod for Z1/KZ900 models. Bright zinc finish.

Sold each.

Order No. **901-325**



717-011

## Z1-900 Foot Rest (Foot Pegs)

Replica of the stock rubber foot rest. Z1/A/B-900 (73-75) and other Kawasaki vintage models. Mounting hardware not included.

Sold in pairs.

Description	Order No.
Rider Footrest	<b>717-011</b>
Passenger Footrest	<b>717-010</b>



## Front Fender Washers

Front fender washers for: H1B, H2-750, S2, S1A/B/C, KH250-A5.

Sold pack of 10.

Order No. **901-300**

## PC Racing Shifter Skins

The PC Racing Shifterskin protects your shoes from ugly shifter marks

- Made from durable, washable neoprene
- Shifterskin provides easier shifting
- Fits most bikes
- Slides on in seconds

Color	Order No.
Black PCSSBLACK	<b>945-120</b>
Gray PCSSGREY	<b>945-121</b>

## Z1/KZ 900/1000 Shift Lever

Shift Lever with rubber tip. Sold each.

Order No. **951-080**

## Kawasaki

Model	Year
KZ900A4/A5	76-77
KZ900B1 LTD	1976
Z1/A/B-900	73-75
KZ1000A1/A2	77-78
KZ1000A3/A3A/A4 MKII	79-80
KZ1000B1/B2/B3/B4 LTD	77-80
KZ1000D1 Z1R	1978
KZ1000D3 Z1R	1980
KZ1000G1 LTD Classic	1980
KZ1000J1/J2/J3	81-83
KZ1000K1/K2 LTD	81-82
KZ1000M1/M2 CSR	81-82





## Z1-900 Side Stand

Replica of the stock Kawasaki Z1-900 side stand. Fits Z1/A/B-900 from 1973-1975 and KZ900A4 1976. Mounting hardware and spring included. Sold each.

Order No. **900-475**



## Kawasaki Side Stand Bolt & Nut Set

2 piece set includes bolts and nut. Fits Kawasaki H2-750.

Order No. **901-335**



900-600

900-601

900-607

900-6011

## Kawasaki Grabrails

Replica of the stock grabrail. Sold each.

## Kawasaki

Model	Year	Notes	Order No.
H1/A/B/C	69-71	Lift Handle	<b>900-602</b>
H1/A/B/C	69-71	Rear Handle	<b>900-607</b>
H2/A/B/C-750 Mach IV	72-73	Lift Handle	<b>900-604</b>
H2/A/B/C-750 Mach IV	72-73	Rear Handle	<b>900-601</b>
Z1/A/B-900	73-75	Rear Handle	<b>900-600</b>
KZ1000A3/A3A/A4 MKII	79-80	Side Handle	<b>900-603</b>
Mushroom Plugs for			<b>900-6011</b>



900-603

900-602

## Front Wheel Dust Cover Screw Kit

Fits Kawasaki H1-500 72-75, H2-750 72-75, KZ900A 76-77 and Z1-900 73-75. Sold set of 3.

Order No. **901-320**



901-320

## Front Disc Brake Rotor **NEW**

Replaces OEM Kawasaki 41080-001. Sold each.

Order No. **331-265**

## Kawasaki

Model	Year
H1D/H1E/H1F-500	73-75
KH500A8	1976
H2/H2A/H2B/H2C-750	72-75
Z1/Z1A/Z1B-900	73-75





## Kawasaki Z1-900B Handlebar Switches

OEM replica of the Z1-900B, KZ900 handlebar switches. Color coded with snap connector. Sold each.

**Right Side Handlebar Switch Z1B-900, KZ900A4, KZ900B1** Order No. **900-157**

This switch has the following functions:  
on-off headlight, starter button and kill switch.

**Left Side Handlebar Switch Z1B-900, KZ900A4, KZ900B1** Order No. **900-158**

This switch has the following functions:  
hi-low headlight, L-R turn signal and horn.



900-305

## Replica Handlebars

Replica of the stock handlebars. Sold each.

### Honda

Model	Year	Notes	Order No.
CB400F Super Sport	75-77	stock bend	<b>900-305</b>
CB400F Super Sport	75-76	stock bend	<b>900-306</b>
CB750F	75-76	stock bend	<b>900-307</b>
CB750KO	69-71	stock bend	<b>900-308</b>
CB750K3-K6	73-76	stock bend	<b>900-307</b>
CB750K	1976	stock bend	<b>900-307</b>

\*\* **900-307** will fit 69-72 models K0-K2, the **900-307** are a taller bar than what is stock on those earlier models

### Kawasaki

H1/A/B/C	69-71	stock bend	<b>900-312</b>
H2/A/B/C-750 Mach IV	72-75	stock bend	<b>900-314</b>
Z1/A/B-900	73-75	stock bend	<b>900-310</b>
KZ1000A3/A3A/A4 MKII	79-80	stock bend	<b>900-311</b>
KZ1000D1 Z1R	1978	stock bend	<b>900-316</b>
KZ1000D3 Z1R	1980	stock bend	<b>900-316</b>



## Kawasaki Handlebar Mount Bolt Kit

Eight piece kit includes bolts and lock washers.  
Fits Kawasaki Z1-900, W1-650, H2-750, KZ1300.

Order No. **900-325**



## Honda CB750K0 Chrome Mirror

Replica of the stock early model CB750 mirror.  
Chrome finish. Sold each.

### Description

CB750K0 Mirror

### Order No.

**716-065**



716-061

## Kawasaki Z1 Mirrors

Replica of the stock Z1 mirror. Black finish.  
Available in long stem or short stem. Sold each.

### Description

Short Stem Mirror

### Order No.

**716-061**

Long Stem Mirror

**716-060**



950-480



950-481



## Kawasaki Z1-900 Indicator Panel Decal

OEM replica. Made of plastic. Sold each.

### Description

Fits Z1-900 (1973)  
Fits Z1A/B-900 (74-75)

### Order No.

950-480  
950-481

## Kawasaki Z1-900 Indicator Lamp Cover Set

OEM replica. Made of plastic. Includes upper cover and lower cover. Sold as a set.

### Description

Fits Z1-900 (1973)  
Fits Z1A/B-900 (74-75)

### Order No.

900-171  
900-170



## Kawasaki H2-750 Rubber Meter Cover

Kawasaki H2-750 Rubber Meter Cover fits speedometer and tachometer. Sold Each. **Meter not included.**

Order No. 900-180



951-010

951-001

## Kawasaki KZ Chrome Gauge Covers

Top and bottom covers for instrument gauges. Kawasaki vintage models, KZ650/750/900/1000. Sold in pairs.

### Description

Top  
Bottom

### Order No.

951-010  
951-001



## H1-500 Speedometer & Tachometer **NEW**

OEM replica. Fits Kawasaki H1-500 1969-1971. Sold each.

### Description

Speedometer MPH  
Speedometer KM  
Tachometer

### Order No.

951-105  
951-106  
951-100



## Instrument Gauge Brackets **NEW**

OEM replica. Two brackets available, Kawasaki Z1/Z1A/Z1B-900 1973-1975 and KZ900/KZ1000 1976-1980. Sold each.

### Description

Z1/Z1A/Z1B-900 OEM Ref. 25008-024  
KZ900/KZ1000 OEM Ref. 25000-039

### Order No.

951-015  
951-016

# Control Levers



## Control Levers

OEM type replacements for Kawasaki and Yamaha vintage applications. Sold each.

### Kawasaki Street

Model	Year	Brake	Clutch
KZ400A1/A2	77-78	628-060	_____
KZ400/D/D3/D4	74-77	628-060	_____
S3/S3A-400 (2-stroke triple)	74-75	628-060	628-160
KH400A3/A4/A5 (2-stroke triple)	76-78	628-060	_____
H1D/E/F-500 (2-stroke triple)	73-75	628-060	628-160
KZ650B1/B2/B2A/B3	77-79	628-060	_____
KZ650C1/C2 Custom	77-78	628-060	_____
H2/A/B/C-750 (2-stroke triple)	72-75	628-060	628-160
KZ750B1/B2 2-Cyl.	76-77	628-060	_____
KZ750E1/E2/E3	80-82	628-061	_____
Z1/A/B-900	73-75	628-060	628-160
KZ900A4/A5	76-77	628-060	_____
KZ1000A1	77	628-060	_____
KZ1000A3/A3A/A4 MKII	79-80	_____	628-161
KZ1000B1/B2 LTD	77-78	628-060	_____
KZ1000E1/E2 Shaft ST	79-80	628-061	_____
KZ1000J1/J2	81-82	628-061	628-161
KZ1300A1/A2/A3/A4	79-82	628-061	628-161

### Yamaha

DT1-250	628-065	628-165
---------	---------	---------



## Grips NEW

Classic Kawasaki OEM style grips for 7/8" handlebars. Replaces 46075-017 left side and 46061-012 right side.

Sold in pairs.

Description	Order No.
Open End Grips	733-230
Closed End Grips	733-231

## Motion Pro Lever & Perch Assemblies

Available in black or polished for cable operated clutch and brake applications. Inexpensive replacement for Japanese OEM units. Split-perch design holder. Sold as an assembly - lever, lever holder (perch) and cable adjuster. **Not for use with hydraulic brake or clutches.**

### Polished

Description	Order No.
Honda Clutch	628-302
Honda Front Brake Cable Type Brake	628-303
Kawasaki/Suzuki/Yamaha Clutch	628-306
Kawasaki/Suzuki/Yamaha Front Brake Cable Type Brake	628-307

### Black

Description	Order No.
Honda Clutch	628-300
Honda Front Brake Cable Type Brake	628-301
Kawasaki/Suzuki/Yamaha Clutch	628-304
Kawasaki/Suzuki/Yamaha Front Brake Cable Type Brake	628-305



628-200

## Lever Holders (Brackets)

Split perch lever holders with adjuster nut and bolt. Yamaha vintage applications. Sold each.

Description	Order No.
Clutch	628-201
Front Brake Cable Type Brake	628-200



## Z1 Clutch Cable Adjuster

Sold as set.

Description	Order No.
Clutch cable adjuster screw & washer	901-340



657-658



655-066

## Control Cables for Vintage Models

### (reference chart)

Stock replacement cables. Sudco offers cables from **Japan** (OEM) and Motion Pro. Sold each. Model listing begins on next page.

### Honda

Description	OEM Reference	Mfg.	Notes	Order No.
Clutch	22870-268-821	Japan	Gray	655-066
Clutch		Motion Pro	Black	655-071
Front Brake	45450-281-000	Japan	Gray	604-066
Speedometer		Motion Pro	Black	652-071
Tachometer		Motion Pro	Black	653-071
Throttle		Japan	Gray	657-066
Throttle (pull)		Motion Pro	Black	657-080A
Throttle (push)		Motion Pro	Black	657-080B

### Kawasaki

Choke	54017-031	Japan	Gray	653-658
Choke		Motion Pro	Black	653-659
Clutch	54011-030	Japan	Gray	655-658
Clutch	54011-030	Japan	Black	655-658B
Clutch	54011-036	Japan	Black	655-660
Clutch	54011-039	Japan	Black	655-638
Clutch	54011-045	Japan	Black	655-661
Clutch	54011-053	Japan	Black	655-663
Clutch		Motion Pro	Black	655-635
Clutch		Motion Pro	Black	655-636
Clutch		Motion Pro	Black	655-637
Front Brake	54005-040	Taiwan	Gray	604-658
Speedometer		Motion Pro	Gray	652-603
Speedometer	54001-030	Japan	Black	652-606
Speedometer	54001-036	Japan	Black	652-604
Speedometer	54001-041	Japan	Black	652-610
Speedometer	54001-043	Japan	Black	652-612
Speedometer	54001-050	Japan	Black	652-607
Speedometer		Motion Pro	Black	652-602
Speedometer		Motion Pro	Black	652-601
Tachometer		Motion Pro	Black	653-601
Tachometer	54018-007	Motion Pro	Gray	653-603
Tachometer	54018-011	Japan	Black	653-604
Tachometer	54018-013	Japan	Black	653-606
Throttle		Motion Pro	Black	657-641
Throttle		Motion Pro	Black	657-659
Throttle	54012-097	Japan	Black	657-663
Throttle	54012-054	Japan	Gray	657-658
Throttle		Motion Pro	Black	657-640
Rear Brake		Motion Pro	Gray	604-665

### Suzuki

Description	OEM Reference	Mfg.	Notes	Order No.
Throttle	58300-33001	Motion Pro	Black	021-962

### Yamaha

Clutch	214-26335-00	Japan	Gray	655-260
	1A0-26335-10			
Front Brake	214-26341-00	Japan	Gray	604-260
Oil Pump	214-26321-00	Japan	Gray	653-260
Speedometer	214-83550-00	Japan	Gray	652-260
Tachometer	214-83560-00	Japan	Gray	653-265
Throttle 1	214-26311-00	Japan	Gray	657-260
Throttle 2	214-26312-00	Japan	Gray	657-261
Throttle	XS650 70-79	Motion Pro	Black	021-960

021-960 - Fits Stock throttle to Mikuni VM34 carburetors.



### Motion Pro Cable Luber

Use to inject lubricant into cable housing. Clamps over cable housing allowing an aerosol can tip to be connected for injection inside. Once the lubricant runs out of far end, the cable is lubricated. Sold each.

Order No. 950-447



### PJ1 Cable Lube

Lubricant for control cables

- Extends cable life
- Cleans and lubricates
- Makes cable pull easier

Sold in 11 fl. oz. aerosol can.

Order No. 899-190

# Control Cables



652-071



653-601

## Control Cables for Vintage Models (application chart)

Stock replacement cables. Sudco offers cables from **Japan** (OEM) and Motion Pro. Sold each.

### Honda

Model	Year	Throttle Set	Throttle Push	Throttle Pull	Choke	Tach	Speedo	Clutch	Front Brake	Rear Brake
CB72 Hawk 305	61-66	657-066	—	—	—	—	—	655-066	604-066	—
CB77 Super Hawk 305	61-68	657-066	—	—	—	—	—	655-066	604-066	—
CB350F Super Sport	72-74	—	—	—	—	—	652-071	—	—	—
CB400F Super Sport	75-77	—	—	—	—	—	652-071	—	—	—
CB500K0/K1/K2	71-73	—	657-080B	657-080A	—	—	652-071	—	—	—
CB550F Super Sport	75-77	—	657-080B	657-080A	—	—	652-071	655-071	—	—
CB550K0/K1	74-75	—	657-080B	657-080A	—	653-071	652-071	655-071	—	—
CB550K	76-78	—	657-080B	657-080A	—	653-071	652-071	655-071	—	—
CB650C Custom	80-81	—	—	—	—	653-071	652-071	—	—	—
CB750F Super Sport	75-76	—	657-080B	657-080A	—	653-071	652-071	655-071	—	—
CB750F Super Sport	77-78	—	—	—	—	—	652-071	655-071	—	—
CB750F Super Sport	79-82	—	—	—	—	—	652-071	—	—	—
CB750K0	1969	—	—	—	—	653-071	652-071	655-071	—	—
CB750K1-K5	70-75	—	657-080B	657-080A	—	653-071	652-071	655-071	—	—
CB750K	1976	—	657-080B	657-080A	—	653-071	652-071	655-071	—	—
CB750K	77-78	—	—	—	—	653-071	652-071	655-071	—	—
CB900F Super Sport	81-82	—	—	—	—	—	652-071	—	—	—
CBX1000 Super Sport	79-82	—	—	—	—	—	652-071	—	—	—

### Kawasaki

F8/F8A-250 Enduro	71-72	—	—	—	—	—	652-606	655-660	—	—
F81M-250 (Offroad MX)	1971	—	—	—	—	—	—	655-660	—	—
KH250A5	1976	657-663	—	—	—	—	—	655-663	—	—
S1A-250 2-stroke triple	1973	—	—	—	—	—	—	655-663	—	—
S1B/S1C-250 2-stroke triple	74-75	657-663	—	—	—	—	—	655-663	—	—
F5/F5A-350 Bighorn	70-71	—	—	—	—	—	652-606	655-660	—	—
F9/F9A-350	72-73	—	—	—	—	653-606	652-606	655-661	—	—
F9B/F9C-350	74-75	—	—	—	—	653-606	652-607	655-661	—	—
S2-350 2-stroke triple	1972	—	—	—	—	—	—	655-663	—	—
S2A-350 2-stroke triple	1973	—	—	—	—	—	652-610	655-663	—	—
KH400A3/A4/A5 2-stroke triple	76-78	657-663	—	—	—	—	652-610	655-663	—	—
S3/S3A-400 2-stroke triple	74-75	657-663	—	—	—	—	652-610	655-663	—	—
KH400A3/A4/A5 2-stroke triple	76-78	657-663	—	—	—	—	652-610	655-663	—	—
H1/A-500 Mach III	69-71	657-658	—	—	653-658	653-603	652-603	655-658**	604-658	604-665
H1B-500 (Disc Brake)	1972	—	—	—	—	—	652-604	—	—	604-665
H1C-500 (Drum Brake)	1972	657-658	—	—	653-658	653-603	652-603	655-658**	604-658	604-665
H1D/H1E/H1F-500	73-75	—	—	—	—	—	652-612	—	—	—
KH500A8 (2-stroke triple)	1976	—	—	—	—	—	652-612	—	—	—
KZ650B3	1979	—	657-640	657-640	—	653-601	652-601	655-637	—	—
H2/H2A-750 Mach IV	72-73	657-659	—	—	653-659	653-604	652-604	655-638	—	—
H2B/H2C-750 Mach IV	74-75	657-659	—	—	—	653-604	652-612	655-638	—	—
KZ900A4/A5	76-77	—	657-640	657-640	—	653-601	652-601	655-635	—	—
KZ900B1 LTD	1976	—	—	—	—	653-601	—	655-637	—	—

\*\* Clutch cable also available in black order number 655-658B



## Kawasaki (cont.)

Model	Year	Throttle Set	Throttle Push	Throttle Pull	Choke	Tach	Speedo	Clutch	Front Brake	Rear Brake
Z1/A/B-900	73-75	_____	657-640	657-640	_____	653-601	652-601	655-635	_____	_____
KZ1000A1	1977	_____	657-640	657-640	_____	653-601	652-601	655-635	_____	_____
KZ1000A2/A2A	1978	_____	657-640	657-640	_____	653-601	_____	655-635	_____	_____
KZ1000A3/A3A/A4 MKII	79-80	_____	657-640	657-640	_____	653-601	652-601	655-637	_____	_____
KZ1000B1/B2/B3/B4 LTD	77-80	_____	_____	_____	_____	653-601	_____	655-637	_____	_____
KZ1000D1 Z1R	1978	_____	_____	_____	_____	_____	652-601	655-636	_____	_____
KZ1000D3 Z1R	1980	_____	_____	_____	_____	_____	_____	_____	_____	_____
KZ1000E1/E2 Shaft ST	79-80	_____	657-640	657-640	_____	_____	652-602	655-637	_____	_____
KZ1000G1 LTD Classic	1980	_____	_____	_____	_____	653-601	_____	_____	_____	_____
KZ1000J1/J2	81-82	_____	_____	657-641	_____	_____	652-602	655-637	_____	_____
KZ1000J3 (Canada model)	1983	_____	_____	_____	_____	_____	652-602	655-637	_____	_____
KZ1000R1/R2 Replica	82-83	_____	_____	_____	_____	_____	_____	655-636	_____	_____
KZ1100A1/A2/A3 Shaft	81-83	_____	_____	_____	_____	_____	_____	655-637	_____	_____

## Suzuki

GT380J/K Lemans	72-73	021-962	_____	_____	_____	_____	_____	_____	_____	_____
-----------------	-------	---------	-------	-------	-------	-------	-------	-------	-------	-------

## Control Cables for Vintage Yamaha

Stock replacement cables. *Made in Japan* (OEM) Sold each.



657-260

## Yamaha

Description	OEM Reference	Mfg.	Notes	Order No.
Clutch	214-26335-00 1A0-26335-10	Japan	Gray	655-260
Front Brake	214-26341-00	Japan	Gray	604-260
Oil Pump	214-26321-00	Japan	Gray	653-260
Speedometer	214-83550-00	Japan	Gray	652-260
Tachometer	214-83560-00	Japan	Gray	653-265
Throttle 1	214-26311-00	Japan	Gray	657-260
Throttle 2	214-26312-00	Japan	Gray	657-261
Throttle	XS650 70-79	Motion Pro	Black	021-960

\*\*XS650 '70-79 (for stock throttle to VM34 Carbs)

## Yamaha Dual Sport (Enduro) & Offroad

Model	Year	Throttle Set	Throttle Top	Throttle Bottom	Oil Pump	Tach	Speedo	Clutch	Front Brake	Rear Brake
DT1/DT1B/DT1C/DT1E-250	68-71	_____	657-260	657-261	653-260	653-265	652-260	655-260	604-260	_____
DT1CMX/DT1MX-250	70-71	_____	657-260	657-261	653-260	653-265	652-260	655-260	604-260	_____
DT2/DT3-250 Enduro	72-73	_____	657-260	657-261	653-260	653-265	652-260	655-260	604-260	_____
RT1/RT1B-360 Enduro	70-71	_____	657-260	657-261	653-260	653-265	652-260	655-260	604-260	_____
RT1M/RT1MX-360	70-71	_____	657-260	657-261	653-260	653-265	652-260	655-260	604-260	_____
RT2/RT3-250 Enduro	72-73	_____	657-260	657-261	653-260	653-265	652-260	655-260	604-260	_____

## Motion Pro Vintage Street Throttle Cables

Replacement throttle cables for carburetor and applications listed. Sold each.



### Ducati

Model	Throttle	Carburetor	Notes	Order No.
Stock	_____	Mikuni TM38	_____	021-907
		Mikuni TM38	Choke Cable for TM38	021-906

### Enfield

500	Stock	Mikuni VM34	_____	021-947
-----	-------	-------------	-------	---------

### Harley-Davidson®

Stock	_____	Mikuni VM36-38, TM36-41	_____	657-900
Stock	_____	Mikuni VM36-38, TM36-41	90° at carb	657-901

### Norton

Stock	_____	Mikuni VM34 single	MK34/39	007-575
Stock	_____	Mikuni VM36-38	MK36/39	007-576
Stock	_____	Mikuni Dual VM32-34	2-into-1	002-025
M.P. YZF style	_____	Keihin Dual 35H FCR	Push/Pull	021-940

### Triumph

TR6/TR7	Stock	Mikuni VM30-34	MK32/43	007-577
T120/T140	Stock	Mikuni VM30-34	MK32/18	007-578

(2 cables required, carb to junction box only)

### Yamaha

RD350 (73-75)	M.P. Turbo	Mikuni TM32-41, VM34-38,	2 into 1, some soldering is required	002-025
RZ350 (84-85)	_____	Keihin PJ34-38, PWK28-39	_____	_____

# Spoke & Nipple Kits, Wheel Weights



## Sudco Spoke & Nipple Kits

Available for front and rear. Kits include inner/outer spokes and nipples.

### Honda

Model	Year	Stainless		Steel	
		Front	Rear	Front	Rear
CB350F/F1 Super Sport	72-74	—	—	900-426	900-427
CB350G Super Sport	1973	—	—	900-426	900-427
CB360	1974	—	—	—	900-427
CB360G	1974	—	—	900-426	900-427
CB360T	75-76	—	—	900-426	900-427
CJ360T	76-77	—	—	—	900-427
CB400F Super Sport	75-77	—	—	900-426	900-427
CB500K0/K1/K2	71-73	900-402	—	900-424	—
CB500T	75-76	900-402	—	900-424	—
CB550K1/K	74-76	900-402	—	900-424	—
CB750K0/K1/K2/K3	69-73	900-402	900-412	900-424	900-425
CB750K4/K5	74-75	900-402	900-412	900-424	900-425
CB750K	76-78	900-402	900-412	900-424	900-425

### Kawasaki

KH250A5	1976	—	—	900-422	900-423
S1A/B/C-250	73-75	—	—	900-422	900-423
S2-350	1972	—	—	900-422	900-423
S2A-350	1973	—	—	900-428	900-423
KZ400A1/A2 Deluxe	77-78	—	—	900-428	900-423
KZ400B1/B2	78-79	—	—	900-428	—
KZ400C1	00-00	—	—	900-422	—
KZ400/D/D3/D4	75-77	—	—	900-428	900-423
KZ400S/S2/S3 Special	75-77	—	—	900-422	900-423
S3/S3A-400	74-75	—	—	900-428	900-423
KH400A3/A4/A5	76-78	—	—	900-428	900-423
KZ440B1/B2	81-82	—	—	900-422	—
H1A-500	69-71	—	—	900-420	900-421
H1B-500 (disc brake)	1972	900-400S	—	900-400	900-421
H1D/H1E/H1F-500	73-75	900-400S	—	900-400	—
KH500A8	1976	—	—	—	900-421
H2/A-750	72-73	900-400S	—	900-400	900-410
H2B/C-750	74-75	900-400S	900-410S	900-400	900-410
Z1/A/B-900	73-75	900-400S	900-410S	900-400	900-410
KZ900A4/A5	76-77	—	900-410S	—	900-410

## Honda Spoke Wheel Weights

Fits Honda models listed. Sold pk/10. *Made in Japan.*

Description	OEM Reference	Weight	Order No.
Honda Spoke CB750K	44609-283-000	5 Grams	901-200
Honda Spoke CB750K	44608-283-000	10 Grams	901-201
Honda Spoke CB750K	44607-283-000	15 Grams	901-202
Honda Spoke CB750K	44606-283-000	20 Grams	901-203

### Honda

Model	Year
CB125TT	1990
CB250 Nighthawk 250	91-97
CB250 Nighthawk 250	99-03
CMX250C Rebel	85-87
CMX250CD Rebel 250 Limited	1986
CB350F Super Sport (4-cyl.)	73-74
CB350G Super Sport (2-cyl.)	1973
CL350K0/K1-K5 Scrambler	68-73
CB360T	75-76
CJ360T	76-77
CL360K0/K1 Scrambler	74-75
CB400F Super Sport	75-77
CB400T1 Hawk	78-79
CM400E	80-81
CB450D Super Sport	1967
CB450K0/K1-K7 Super Sport	65-74
CL450 Scrambler 450	1967
CL450K1-K6 Scrambler	68-74
CM450E	82-83
CB500K0/K1/K2 (4-cyl.)	71-73
CB500T (2-cyl.)	75-76
CB550F Super Sport	75-77
CB550K0/K1	74-75
CB550K	76-78
CB650	80-82
NX650	88-89
CB750A Automatic	76-77
CB750F Super Sport	75-76
CB750K0-K5	69-75
CB750K (SOHC)	76-78
CB750K (DOHC)	79-82
GL1000 Goldwing	75-77
GL1000L Goldwing LTD	1976

## Kawasaki Z1-900 Rear Wheel Damper Set

Kawasaki Reference - 42014-021. Sold as a set. (qt. 6 pieces)

Order No. 900-168

Model	Year
H2B/C-750 Mach IV 2-stroke	74-75
Z1/A/B-900	73-75
KZ900A4/A5	76-77





## Kawasaki Z1-900 Seat Assembly

OEM style seat with black metal pan similar to the stock version. Sold as a complete unit with hinges and rubber mounts.

Decription	Order No.
Seat Assembly	<b>900-100</b>
Seat Cover, Black	<b>900-060</b>
Seat Foam	<b>900-112</b>



900-112

## Replacement Seat Foam

OEM style replacement foam for stock seat. Sold each

### Honda

Model	Year	Order No.
CB750K2-K6	72-76	<b>900-115</b>

### Kawasaki

H1-500	73-75	<b>900-114</b>
KH500	1976	<b>900-114</b>
H2/A-750 Mach IV (2-stroke)	72-73	<b>900-113</b>
Z1/A/B-900	72-76	<b>900-112</b>
KZ1000D1-D3 Z1R	78-80	<b>900-111</b>
KZ1000	77-78	<b>900-112</b>



## Kawasaki Reproduction Seat Trim

Reproduction seat trim. Sold in pairs.

### Kawasaki

Application	Year	Order No.
S2/S2A-350	72-73	<b>900-107</b>
S3A-400 & KH400	75-77	<b>900-107</b>
H2-750	72-73	<b>900-107</b>



## Replacement Seat Covers

OEM style replacement seat covers for stock seat. Sold each.

### Honda

Model	Year	Notes	Order No.
CL72 Scrambler 250	62-65	with belt and rivets	<b>900-011</b>
CL77 Scrambler 305	65-68	with belt and rivets	<b>900-011</b>
CB400F Super Sport	75-77	_____	<b>900-007</b>
CB750K0	1970	Seat Cover only, no Honda logo	<b>900-001</b>
CB750K1	1971	with logo	<b>900-014</b>
CB750K2-K3	72-73	_____	<b>900-012</b>
CB750K4-K6	74-76	_____	<b>900-013</b>

### Kawasaki

Model	Year	Note	Order No.
S1A-250	1972	_____	<b>900-064</b>
KH250	1976	_____	<b>900-080</b>
S2A-350 Mach II	1972	_____	<b>900-064</b>
KH400	74-75	_____	<b>900-080</b>
H1-500 Mach III	1969	with gold trim	<b>900-073G</b>
H1-500 Mach III	1969	with silver trim	<b>900-073S</b>
H1-500 Mach III	70-71	_____	<b>900-074</b>
KH500	73-76	_____	<b>900-081</b>
H2-750 Mach IV (2-stroke)	1972	_____	<b>900-064</b>
KZ900	1976	_____	<b>900-083</b>
Z1/A/B-900	73-75	_____	<b>900-060</b>
KZ1000A1/A2	77-78	_____	<b>900-077</b>
KZ1000D1 Z1R	1978	_____	<b>900-062</b>
KZ1000D3 Z1R	1980	_____	<b>900-082</b>
KZ1100B1/B2 GPz	81-82	_____	<b>900-040</b>
KZ1300A1/A2/A3/A4	79-82	_____	<b>900-075</b>

### Suzuki

GS400B/XB/C/EC	77-78	_____	<b>900-050</b>
GS425N	1979	_____	<b>900-050</b>



## Seat Belt

55cm long, no buckle. Sold each.

Order No. **900-105**

# Headlight Brackets & H2 Taillight Bracket



900-162

900-163



## Kawasaki Z1-900 Fork Covers

These fork covers are used for mounting the headlight shell onto the fork tubes. Sold each, left and right sides.

Model	Description	Order No.
Early Z1 (1973)	Fork Cover, RH side	900-162
Early Z1 (1973)	Fork Cover, LH side	900-163

## Kawasaki Z1R-1000 Headlight Stay (Fork Covers)

These fork covers are used for mounting the headlight assembly on to the fork tubes. Sandcast aluminum with semi-flat black finish. Sold as a set, left and right sides. Kawasaki OEM reference: 44033-1011 LH Side and 44033-1012 RH Side. Fits Kawasaki KZ1000D1 Z1R (1978) and KZ1000D3 Z1R (1980).

Order No. 900-145



## Kawasaki H2-750 License Plate Bracket

Replica of the stock license plate bracket. Sold each.

Order No. 900-182



## Kawasaki H2-750 72-73 Headlight Bracket

Replica of the stock headlight brackets, semi-flat black finish. Sold as a pair.

Order No. 722-575



## Kawasaki H2-750 Tail Inner Plate

Replica of the stock body part. Sold each.

Order No. 900-181





721-602

## Headlight Shell Assembly

Similar to OEM Kawasaki unit. Complete assembly includes shell, rim & retainer. (headlight & wiring not included)

### Black

Black Headlight Shell (body) with chrome headlight rim/retainer. Order No. [721-602](#)  
OEM Reference 23005-1016.

### Chrome

Chrome Headlight Shell (Body) with chrome Rim/Retainer Order No. [721-603](#)



## Headlight Rim & Retainer

Chrome finish (rim) includes sealed beam retaining rim, retainer and hardware. Headlight not included. Sold each.

### Honda

#### Rim/Retainer Assembly

OEM Reference 33101-300-673 Order No. [722-530](#)  
CB750K

### Kawasaki

#### Rim/Retainer Assembly

OEM Reference	Order No. <a href="#">721-600</a>
23006-038	
KH500A6 2-stroke triple	1976
KZ550A1/A2/A3/A4	80-83
KZ550C1/C2/C3/C4 LTD	80-83
KZ650B1/B2/B2A/B3	77-79
KZ650C1/C2/C3 Custom	77-79
KZ650D1/D2 SR	78-79
KZ650E1	1980
KZ650F1	1980
KZ650H1/H2/H3 CSR	81-83
KZ750B1/B2/B3/B4/G1 (2 cyl)	77-80
KZ750G1 LTD (2 cyl)	1980
KZ750E1/E2/E3	80-82
KZ750H1/H2/H3/H4 LTD	80-83
KZ750M1 CSR	1982
Z1/A/B-900	73-75
KZ900A4	1976
KZ900B1 LTD	1976
KZ1000A1/A2	77-78
KZ1000A3/A3A/A4 MKII	79-80
KZ1000B1/B2/B3/B4 LTD	77-80
KZ1000E1/E2 Shaft ST	79-80
KZ1000J1/J2/J3	81-83
KZ1000K1/K2	81-82
KZ1000M1/M2	81-82
KZ1100A1/A2 Shaft	81-82



## Headlight NEW

7" standard lens headlight includes H-4 Bulb. Sold each.

Order No. [721-605](#)



## Headlight & Turn Signal Grommet Set

This complete set is used for mounting turn signals on to Kawasaki KZ headlight shell. Set includes rubber grommets and ground collar wire mounts. Turn signals not included. Sold as a set as shown in photo.

Order No. [900-185](#)



## Kawasaki H1-500 72-73 Headlight Bolts

Chrome finish. Set includes 2 bolts, and 2 washers.

Order No. [901-322](#)

# Fuel Tank Products



Before

After

We cut this gas tank in half and treated half of it with Rustol



## Kawasaki Z1-900 Fuel (Gas) Tank

Replica of the stock fuel tank. Fuel Tank only.  
Z1/A/B-900 (73-75) model only. Sold each.

Order No. **900-152**

### Emblems for Kawasaki Z1-900 Fuel (Gas) Tank

Order No. **900-382** Z1-900 (1973)

Order No. **900-381** Z1-900 (1974)



## Z1-900 Fuel (Gas) Tank Cap Assembly

OEM replica of the stock cap. Z1/A/B-900 (73-75) model only.  
Sold each.

Order No. **900-151**

## KZ900 Hinged Locking Gas Cap **NEW**

Fits the following models: KZ200 (78-79), KH250 (1976) KH400 (76-78), H1-D/H1E/H1F-500 (73-75), KZ750 2 cylinder 76-80, KZ900 (76-77).  
Sold each.

Order No. **900-147**



## Kawasaki Rubber Fuel Tank Band

Mounts on to the rear of the fuel tank for applications listed.  
Sold each. Available for the following Kawasaki applications.

### Kawasaki

Model	Year	OEM Reference	Order No.
F6/A/B-125	71-73	92072-029	<b>900-155</b>
F7-175	1971	92072-029	<b>900-155</b>
S2-350/A	72-73	92072-029	<b>900-155</b>
H2-750	1972	92072-029	<b>900-155</b>
Z1/A/B-900	73-75	92072-042	<b>900-154</b>
KZ900A4	1976	92072-042	<b>900-154</b>
KZ900B1 LTD	1976	92072-042	<b>900-154</b>
KZ1000A1/A2	77-78	92072-042	<b>900-154</b>
KZ1000B1/B2 LTD	77-78	92072-042	<b>900-154</b>
KZ1000D1 Z1R	1978	92072-042	<b>900-154</b>

## Rustol

Rustol gives excellent results with little or no work required. It is safe and non-corrosive to all metals, rubber coatings and paint. While destroying existing rust, it forms a protective bond that prevents new rust from forming later. Rustol is odorless unlike conventional rust removers, and is shipped in a concentrated form. Believe it or not, the same batch of Rustol can be used many times.

**Note:** Rustol should be diluted according to instructions before use.

Description	Order No.
1 Quart Bottle	<b>800-250</b>
1 Gallon Bottle	<b>800-252</b>
20 liter bottle (bag in a box)	<b>800-253</b>

**KAWASAKI** 900-381

**HONDA** 900-377

**YAMAHA** 900-389

**YAMAHA** 900-388

## Fuel (Gas) Tank Emblems

OEM replica emblems. Fits stock fuel tank. Mounting hardware not included, use stock hardware. Sold each.

### Honda

Model	Year	Description	Order No.
CB750K0	1969	Black Honda letters with silver trim	<b>900-377</b>

### Kawasaki

Z1-900	1973	Kawasaki letters with black trim	<b>900-382</b>
Z1A-900	1974	White Kawasaki letters with black trim	<b>900-381</b>

### Yamaha

DT1-250		Yamaha Red	<b>900-389</b>
DT1-250		Yamaha Black	<b>900-388</b>
XS650		Yamaha Red	<b>900-389</b>
XS650		Yamaha Black	<b>900-388</b>



900-375



900-378



900-380



900-384

## Body Parts

Replica of the stock body parts. Not painted. Sold each.

### Kawasaki

Description	Order No.
<b>H2-750 2-Stroke Triple 72-73</b>	
Left Side Cover	900-756
Front Fender	900-725
Rear Tail Section	900-675
Chain Guard	900-651

### Z1-900/A/B 73-75

Left Side Cover (Fiberglass)	900-752
Left Side Cover Replica (Plastic)	900-752A
Right Side Cover (Fiberglass)	900-753
Right Side Cover Replica (Plastic)	900-753A

### KZ1000A3/A3A/A4 MKII 79-80

Left Side Cover	900-754
Chain Guard	900-653

### KZ1000D1 /D3 Z1R 1978 & 1980

Left Side Cover	900-750
Right Side Cover	900-751

### KZ1000R1/R2 Eddie Lawson Replica (ELR) 82-83

Cowling (Fairing)	900-712
-------------------	---------

### KZ1100B1/B2 GPz 81-82

Cowling (Fairing)	900-712
-------------------	---------

### Z1000R1/R2 Eddie Lawson Replica (ELR) 82-83

Winshield, Fits 900-712 cowling.	900-501
----------------------------------	---------

## Side Cover Emblems

OEM replica emblems. Fits stock side covers..

Mounting hardware not included. Sold in pairs and each as indicated.

### Honda

Model	Year	Description	Qt	Order No.
CB750K0		Wing Emblem, Gold with White Wing and Black Honda Letters	Pair	900-378
CB750K0		Wing Emblem, Black with White Wing and Black Honda Letters	Pair	900-379

### Kawasaki

H1-500	1969	Mach III 500 Emblem Black and Red Letters	Each	900-375
Z1-900	73-74	900 Double Overhead Camshaft, White Numbers	Pair	900-380
Z1R		White Kawasaki (European models) Numbers (Z1000) with Red Z1R Letters	Each	900-384

## Decal Sets for Vintage Japanese Models (For Restoration)

OEM replica decals. Sold in sets for models listed.

### Honda

Model	Year	Description	Order No.
CB400F Super Sport	75-77	Red Paint Decal Kit	950-083
CB400F Super Sport	75-77	Side Cover Set	950-084

### Kawasaki

F4-250 Sidewinder	1970	Side Cover	950-097
F7-175 Enduro	1971	Decal Kit	950-096
F5-350 Bighorn	1970	Decal Kit	950-094
F5A-350 Bighorn	1971	Decal Kit	950-093
F8-250	1971	Decal Kit	950-095
F9-350 Rotary Valve	1972	Decal Kit	950-092
S2-350	1972	Decal Kit	950-091
H1-500 Mach III	1969	White Oil Tank Decal	950-080
H1-500 Mach III	1969	Gray Oil Tank Decal	950-081
H1-500 Mach III	1969	White Body Decal Kit	950-086
H1-500 Mach III	1970	Red Body Decal Kit	950-087
H2-750 Mach IV	1972	Gold Body Decal Kit	950-088
H2-750 Mach IV	1972	Blue Body Decal Kit	950-089
H2-750 Mach IV	1973	Purple/Gold Body Decal Kit	950-090
KZ1000A3/A3A/A4 MKII	79-80	Decal Kit	950-085



# Ignition Coils & NGK Racing Cables

VINTAGE  
INTAKE  
ENGINE  
SUSPENSION  
CONTROL  
ELECTRICAL  
CHEMICAL  
TOOLS  
WATERCRAFT



## Ignition Coil for Kawasaki & Suzuki

Point type ignition coil for the Kawasaki and Suzuki models listed.

**Note:** Ignition Coils are not marked 1 & 4 or 2 & 3. Sold each.

Order No. [618-110](#)

### Ignition Coil Specifications

**Low Tension Wires:** 39cm (15") long with female spad connectors at coil and male bullet connectors on the other end.

**Spark Plug Wires (HT Leads) :** 57.5cm (24") long with a 30cm (12") long protective sheath.

**Center to Center Mounting Distance:** 90mm between mounting screw holes.

## Kawasaki

Model	Year
KZ400A1/A2	77-78
KZ400B1/B2	78-79
KZ400C1	1978
KZ400/D/D3/D3	74-77
KZ400H1 LTD	1979
KZ400S/S2/S3 Special	75-77
KZ440A1	1980
KZ440B1	1980
KZ440D1	1980
KZ650B1/B2/B2A/B3	77-79
KZ650C1/C2/C3 Custom	77-79
KZ650D1/D2 SR	78-79
KZ650E1 LTD	1980
KZ650F1	1980
KZ750B1/B2/B3/B4 (2-cylinder)	76-79
KZ750G1 LTD (2-cylinder)	1980
KZ900A4/A5	76-77
KZ900B1 LTD	1976
Z1/A/B-900	73-75
KZ1000A1/A2	77-78
KZ1000B1/B2/B3 LTD	77-79
KZ1000C1/C1A/C2 Police	78-79

## Suzuki

GS550B/C/EC/N	77-79
GS550LN	1979
GS750B/C/EC/N/EN	77-79
GS750LN	1979
GS850GN	1979
GS1000C/EC/N/EN	78-79
GS1000LN	1979
GS1000SN	1979



## Ignition Coil Set for Kawasaki H2-750

These OEM style replica high tension coils fit Kawasaki's legendary H2-750 2-stroke triple, 1972-1975. Sold as a complete set of 3 coils, wires, & caps. Kawasaki OEM reference: 21121-064.

Order No. [618-112](#)



## Universal 12 Volt Ignition Coil

This Universal 12 volt Ignition Coil comes complete with mounting Bracket. 12 volts, 5.0 ohms.

Order No. [618-114](#)



[207-102](#)

[207-101](#)

## NGK Premium Quality Racing Cables

Available in straight or 90 ° resistor covers. Sold each.

- Water Resistant, rugged silicone insulation
- High Output stranded copper wire
- 5k ohm ceramic resistor cover for excellent defense against RFI (radio frequency interference)

### 90 ° Resistor Covers

Cap Type	Wire Length	Order No.
Removable	50cm (20")	<a href="#">207-101</a>
Removable	100cm (39")	<a href="#">207-104</a>
Solid	50cm (20")	<a href="#">207-103</a>
Solid	100cm (39")	<a href="#">207-105</a>

### Straight Resistor Covers

Removable	50cm (20")	<a href="#">207-100</a>
Solid	50cm (20")	<a href="#">207-102</a>





618-867

## Dyna 2000 Digital Performance

The Dyna 2000 Digital Performance Ignition represents a break through in motorcycle ignition flexibility. The Dyna 2000 system consists of a state-of-the-art microprocessor controlled ignition module along with an adjustable Dyna dual sensor crank trigger. For the first time you can actually set the ignition timing to what you want to maximize engine performance. A number of different advance modes and a broad range rev limiter let you tailor the ignition to your needs. **Note:** Sudco part numbers with an **asterisk\*** come with compatible Dyna Ignition coils.

### Honda

Application	Year	Dyna No.	Order No.
CB750/900/1100 DOHC (with coils*)	79-82	DDK1-5C	<b>618-861*</b>

### Kawasaki

KZ550D1 GPZ (with coils*)	1981	DDK2-3C	<b>618-869*</b>
KZ650B/C/E/F	77-80	DDK2-2	<b>618-867</b>
KZ650B/C/E/F (with coils*)	77-80	DDK2-2C	<b>618-856*</b>
KZ750/ZX750	80-84	DDK2-2	<b>618-867</b>
KZ750/ZX750 (with coils*)	80-84	DDK2-2C	<b>618-856*</b>
Z1-900/KZ900	73-76	DDK2-1	<b>618-865</b>
Z1-900/KZ900 (with coils*)	73-76	DDK2-1C	<b>618-866*</b>
ZX900A1/A2 Ninja 900R	84-85	DDK2-4	<b>618-834</b>
KZ1000/1100	77-85	DDK2-1	<b>618-865</b>
KZ1000/1100 (with coils*)	77-85	DDK2-1C	<b>618-866*</b>
KZ1100 GPz modified	81-84	DDK2-1	<b>618-865</b>
KZ1100 GPz modified (with coils*)	81-84	DDK2-1C	<b>618-866*</b>
ZX1000A1/A2 Ninja 1000R	86-87	DDK2-4	<b>618-834</b>

### Suzuki

GS550/750/850	77-81	DSK3-2	<b>618-870</b>
GS1000/1100/1150	77-85	DSK3-2	<b>618-870</b>
GS1000/1100/1150 (with coils*)	77-85	DSK3-2C	<b>618-871*</b>

### Yamaha

FJ1100/1200	84-92	DDK7-1	<b>618-845</b>
-------------	-------	--------	----------------

## Boyer Bransden Electronic Ignition

Boyer Bransden ignitions are fully electronic "breakerless" kits and are compatible with positive or negative ground systems. Boyer ignitions are capable of reliable operation up to 10,000 RPM on most 4-stroke applications. "Reliable As Rock" reputation and virtually maintenance free when installed on a fully functional charging system. Available for the following applications:

Application	Order No.
BSA/Triumph triple	<b>618-902</b>
BSA/Triumph twin (Unit Type Twin)	<b>618-901</b>
BSA/Triumph single (Unit Type Single)	<b>618-903</b>
Norton Twin (Atlas, P11, N15, Commando)	<b>618-900</b>
Yamaha XS650 (70-78)	<b>618-904</b>



618-727

618-763

## Dyna-S Electronic Ignition

The Dyna-S is a complete self-contained electronic ignition built with the latest state-of-the-art engineering. The Dyna S is completely housed behind the ignition cover and uses a magnetic rotor with the original spark advancer, so the factory advance curve is maintained. Tidy, no fuss installation. Recommended DYNA Ignition Coil is listed after Order No.

### Ducati

Application	Year	Dyna No.	Order No.	Dyna Ign. Coil
750 Twins	72-74	DS4-1	<b>618-727</b>	<b>618-763</b>

### Honda

CB350F/CB400F	72-77	DS1-1	<b>618-720</b>	<b>618-760</b>
CB500/550/750	69-78	DS1-2	<b>618-721</b>	<b>618-750</b>
GL1000	75-79	DS1-3	<b>618-722</b>	<b>618-750</b>

### Kawasaki

KZ550/650/750 (4-cyl.)	ALL	DS2-2	<b>618-724</b>	<b>618-750</b>
Z1-900/KZ900 (4-cyl.)	73-76	DS2-1	<b>618-723</b>	<b>618-750</b>
KZ1000/1100 (4-cyl.)	77-85	DS2-1	<b>618-723</b>	<b>618-750</b>

### Moto Guzzi

V35/V50/V65	ALL	DS5-1	<b>618-728</b>	<b>618-763</b>
-------------	-----	-------	----------------	----------------

### Suzuki

GS550-1100 (4-cyl.)	77-81	DS3-2	<b>618-726</b>	<b>618-750</b>
GS1000/1100 (4-cyl.)	82-83	DS3-2	<b>618-726</b>	<b>618-750</b>



618-901

# Ignition Tune-Up Kits



634-031 Honda XL350

## Sudco Ignition (Tune-Up) Kits

These quality ignition kits include contact points and condensers. (No Spark Plugs). Sold as kits for applications listed. Individual parts (each) are also available for models not listed. See Contact Points and Condenser pages. *Made in Japan.*

### Honda Street

Model	Year	Ignition	Ignition Kit
CT70 Trail 70	76-82	Hitachi	634-001
CT70HK0/HK1 Trail 70H	70-73	Hitachi	634-001
CT70HK0/HK1 Trail 70H	70-73	Mitsubishi	634-025
CT70K0 Trail 70	69-71	Hitachi	634-001
CT70K1-K4 Trail 70	72-75	Hitachi	634-001
XL70K0/K1	74-75	Hitachi	634-001
XL70K0/K1	74-75	Mitsubishi	634-025
XL70	1976	Hitachi	634-001
XL70	1976	Mitsubishi	634-025
XL75	77-79	Hitachi	634-001
XL80S	80-85	Hitachi	634-001
CL90 Scrambler 90	67-69	Kokusan	634-011
CL90 Scrambler 90	67-69	ND	634-012
CM91	1969	Kokusan	634-027
CM91	1969	ND	634-028
CT90K0 Trail 90	66-68	Kokusan	634-027
CT90K0 Trail 90	66-68	ND	634-028
CT90K1-K6 Trail 90	69-75	Kokusan	634-027
CT90K1-K6 Trail 90	69-75	ND	634-028
CT90 Trail 90	76-79	Kokusan	634-027
CT90 Trail 90	76-79	ND	634-028
S90 Super 90	64-69	Kokusan	634-011
S90 Super 90	64-69	ND	634-012
CB100K0/K1/K2 Super Sport 100	70-72	ND	634-002
CL100K0/K1/K2 Scrambler 100	70-72	ND	634-002
CL100S Scrambler 100S	1971	ND	634-002
CL100S2/S3 Scrambler 100S	72-73	ND	634-002
SL100K0/K1/K2/K3 Motosport 100	70-73	ND	634-002
XL100K0/K1	74-75	ND	634-002
XL100	76-78	ND	634-002
CB125S/S1/S2	73-75	ND	634-002
CB125S	1976	ND	634-002
CB125S	1978	ND	634-002

### Honda Street

Model	Year	Ignition	Ignition Kit
CL125S/S1 Scrambler 125	73-74	ND	634-002
SL125K0/K1/K2 Moto Sport	71-73	ND	634-002
CA175 (CD175) Touring 175	68-69	ND	-----
CA175 (CD175) Touring 175	68-69	Hitachi	-----
CA175K3 Touring 175	69-70	ND	-----
CA175K3 Touring 175	69-70	Hitachi	-----
CB175K3-K7 Super Sport	69-73	ND	-----
CB175K3-K7 Super Sport	69-73	Hitachi	-----
CL175K0/K3-K7 Scrambler	68-73	ND	-----
CL175K0/K3-K7 Scrambler	68-73	Hitachi	-----
SL175K0/K1 Motosport 175	70-72	ND	-----
SL175K0/K1 Motosport 175	70-72	Hitachi	-----
XL175K0/K1/K2	73-75	ND	634-019

The following CL72/CB72/CL77 models use ND ignition.

Verify condenser when ordering. See Honda condensers for photos.

Points are same for all models.

CB72 Hawk 250	61-68	ND	-----
CB72 Hawk 250	61-68	ND	-----
CL72 Scrambler 250	62-65	ND	-----
CL72 Scrambler 250	62-65	ND	-----
CB77 Super Hawk 305	61-68	ND	-----
CB77 Super Hawk 305	61-68	ND	-----
CL77 Scrambler 305	65-68	ND	-----
CL77 Scrambler 305	65-68	ND	-----
CB350G (2-cyl.)	1973	ND	634-005
CB350K0/K1-K4 (2-cyl.)	68-73	ND	634-005
CB350F/F1 Supersport (4-cyl.)	72-74	ND	634-009
CL350K0/K1-K5 Scrambler	68-73	ND	634-005
SL350K0/K1/K2 Moto Sport	69-73	ND	634-005
XL350K0/K1	74-75	ND	634-031
XL350	76-78	ND	634-031
CB360K0	1974	ND	634-006
CB360G	1974	ND	634-006
CB360T	75-76	ND	634-006
CJ360T	76-77	ND	634-006
CL360K0/K1 Scrambler 360	74-75	ND	634-006
CB400F Super Sport	75-77	ND	634-009
CB450K0 Super Sport	65-68	Kokusan	634-007
CB450K1-K7 Super Sport	68-74	Kokusan	634-007
CL450K1-K6 Scrambler	68-74	Kokusan	634-007
CB500/K1/K2 (4-cyl.)	71-73	Hitachi	634-008
CB500T (2-cyl.)	75-76	Kokusan	634-007
CB550F Super Sport	75-77	Hitachi	634-008
CB550K0/K1	74-75	Hitachi	634-008
CB550K	76-78	Hitachi	634-008
CB750A Automatic	76-78	Hitachi	634-008
CB750K0/K1-K5	69-75	Hitachi	634-008
CB750K	76-78	Hitachi	634-008
CB750F Super Sport	75-78	Hitachi	634-008
GL1000 Goldwing	75-79	Kokusan	634-014
GL1000L Goldwing LTD	1975	Kokusan	634-014

### Honda ATV

ATC70/K1	73-74	Hitachi	634-001
ATC70	78-85	Hitachi	634-001
ATC90/K1/K2/K3	70-75	ND	634-028
ATC90	76-78	ND	634-028
FL250 Odyssey	78-80	ND	634-037

## Honda Dual Sport & Offroad

Model	Year	Ignition	Ignition Kit
Z50AK0/AK1-AK6 Mini	68-75	Hitachi	<b>634-001</b>
Z50A	76-78	Hitachi	<b>634-001</b>
Z50R	79-87	Hitachi	<b>634-001</b>
Z50RD Special	1986	Hitachi	<b>634-001</b>
CT70 Trail 70	76-79	Hitachi	<b>634-001</b>
CT70 Trail 70	80-82	Hitachi	<b>634-001</b>
CT70 Trail 70	80-82	ND	—
CT70HK0/HK1	70-73	Hitachi	<b>634-001</b>
CT70HK0/HK1	70-73	Mitsubishi	<b>634-025</b>
CT70K0 Trail 70	69-71	Hitachi	<b>634-001</b>
CT70K1-K4 Trail 70	72-75	Hitachi	<b>634-001</b>
SL70K0/K1 Moto Sport	71-73	Hitachi	<b>634-001</b>
SL70K0/K1 Moto Sport	71-73	Mitsubishi	<b>634-025</b>
XL70K0/K1	74-75	Hitachi	<b>634-001</b>
XL70K0/K1	74-75	Mitsubishi	<b>634-025</b>
XL70	1976	Hitachi	<b>634-001</b>
XL70	1976	Mitsubishi	<b>634-025</b>
XL75	77-79	Hitachi	<b>634-001</b>
XR75K0/K1/K2	73-75	Hitachi	<b>634-001</b>
XR75	1976	Hitachi	<b>634-001</b>
CT90K0 Trail 90	66-68	Kokusan	<b>634-027</b>
CT90K0 Trail 90	66-68	ND	<b>634-028</b>
CT90K1-K6 Trail 90	69-75	Kokusan	<b>634-027</b>
CT90K1-K6 Trail 90	69-75	ND	<b>634-028</b>
CT90 Trail 90	76-79	Kokusan	<b>634-027</b>
CT90 Trail 90	76-79	ND	<b>634-028</b>
SL100K0/K1-K3 Motosport 100	70-73	ND	<b>634-002</b>
XL100K0/K1	74-75	ND	<b>634-002</b>
XL100	76-78	ND	<b>634-002</b>
SL125K0/K1/K2 Moto Sport	71-73	ND	<b>634-002</b>
SL175K0/K1 Motosport 175	70-72	ND	—
SL175K0/K1 Motosport 175	70-72	Hitachi	<b>634-004</b>
XL175K0/K1/K2	73-75	ND	—
CR250M1/M Elsinore	73-76	Kokusan	—
XL250/K1/K2 Moto Sport	72-76	ND	<b>634-031</b>
SL350K0/K1/K2 Moto Sport	69-73	ND	<b>634-005</b>
XL350K0/K1	74-75	ND	<b>634-031</b>
XL350	76-78	ND	<b>634-031</b>

## Kawasaki Street

G3SS-90 Bushmaster	69-70	Kokusan	<b>634-603</b>
G3SSA/B/C/D-90	71-74	Kokusan	<b>634-603</b>
G3TR-90 Bushmaster	69-70	Kokusan	<b>634-603</b>
MC1/MC1A/MC1B-90	73-75	Kokusan	<b>634-603</b>
G3SSE-100	1975	Kokusan	<b>634-603</b>
G3TRA-100	1971	Kokusan	<b>634-603</b>
G4TR/G4TRA-100 Trail Boss	70-71	Kokusan	<b>634-603</b>
G4TRB/G4TRC-100	72-73	Kokusan	<b>634-603</b>
G4TRD/G4TRE-100	74-75	Kokusan	<b>634-603</b>
G5/A/B/C-100	72-75	Kokusan	<b>634-603</b>
KH100B7/B8	76-77	Kokusan	<b>634-603</b>
KZ200A1/A1A/A2	78-79	Kokusan	<b>634-617</b>
KH250A5 (2-stroke triple)	1976	Kokusan	<b>634-602</b>
KZ250D1 LTD	1980	Kokusan	<b>634-617</b>
S1A/S1B/S1C-250	73-75	Kokusan	<b>634-602</b>
S2/S2A-350 (2-stroke triple)	72-73	Kokusan	<b>634-602</b>
KZ400A1/A2 Deluxe	77-78	ND	<b>634-609</b>
KZ400B1/B2	78-79	Kokusan	<b>634-615</b>
KZ400C1	1978	Kokusan	<b>634-615</b>
KZ400/D/D3/D4	74-77	ND	<b>634-609</b>
KZ400H1 LTD	1979	Kokusan	<b>634-615</b>
KZ400S/S2/S3 Special	75-77	ND	<b>634-609</b>
S3/S3A-400 (2-stroke triple)	74-75	Kokusan	<b>634-602</b>

## Kawasaki Street

Model	Year	Ignition	Ignition Kit
KZ440A1 LTD	1980	Kokusan	<b>634-615</b>
KZ440B1	1980	Kokusan	<b>634-615</b>
KZ440D1 LTD Belt	1980	Kokusan	<b>634-615</b>
H1B-500 (2-stroke triple)	1972	Mitsubishi	<b>634-608</b>
KZ550A1	1980	Kokusan	<b>634-612</b>
KZ650B1/B2/B2A/B3	77-79	Kokusan	<b>634-612</b>
KZ650C1/C2/C3 Custom	77-79	Kokusan	<b>634-612</b>
KZ650D1/D2 SR	78-79	Kokusan	<b>634-612</b>
KZ650E1 LTD	1980	Kokusan	<b>634-612</b>
KZ650F1	1980	Kokusan	<b>634-612</b>
KZ750B1/B2 2-cylinder	76-77	ND	<b>634-609</b>
KZ750B3/B4 2-cylinder	78-79	Kokusan	<b>634-615</b>
KZ750G1 LTD 2-cylinder	1980	Kokusan	<b>634-615</b>
KZ900A4/A5	76-77	Kokusan	<b>634-611</b>
KZ900B1 LTD	1976	Kokusan	<b>634-611</b>
Z-1/A/B-900	73-75	Kokusan	<b>634-611</b>
KZ1000A1/A2/A2A	77-78	Kokusan	<b>634-611</b>
KZ1000B1/B2/B3 LTD	77-79	Kokusan	<b>634-611</b>
KZ1000C1/C1A/C2 Police	78-79	Kokusan	<b>634-611</b>
KZ1000D1 Z1R	1978	Kokusan	<b>634-611</b>

## Kawasaki ATV

KLT200A1	1981	Kokusan	<b>634-617</b>
----------	------	---------	----------------

## Kawasaki Dual Sport & Offroad

KD80/A2	75-76	Kokusan	<b>634-603</b>
KD80M1-M8	80-88	Kokusan	<b>634-603</b>
MC1/MC1A/MC1B-90 Dual	73-75	Kokusan	<b>634-603</b>
MC1M/MC1M-90	74-75	Kokusan	<b>634-603</b>
G3TR-90 Bushmaster	69-70	Kokusan	<b>634-603</b>
G3TRA-100	1971	Kokusan	<b>634-603</b>
G4TR/G4TRA-100 Trail Boss	70-71	Kokusan	<b>634-603</b>
G4TRB/G4TRD-100	72-73	Kokusan	<b>634-603</b>
G4TRD/G4TRE-100	74-75	Kokusan	<b>634-603</b>
G5/A/B/C-100	72-75	Kokusan	<b>634-603</b>
KD100M1/M2/M3/M4	76-79	Kokusan	<b>634-603</b>
KE100A5-A10	76-81	Kokusan	<b>634-603</b>
KE100B1-B14	82-95	Kokusan	<b>634-603</b>
KM100A1-A7	76-81	Kokusan	<b>634-603</b>
KV100A7	1976	Kokusan	<b>634-603</b>
KD125/A2/A3/A4/A5	75-79	Kokusan	<b>634-603</b>
KE125A3/A4/A5/A6/A7/A8	76-81	Kokusan	<b>634-603</b>
KE125A9/A10	82-83	Kokusan	<b>634-603</b>
KS125/A	74-75	Kokusan	<b>634-603</b>
F8/A-250	71-72	Kokusan	<b>634-606</b>
F11/A/B-250	73-75	Kokusan	<b>634-606</b>
KL250A1/A1A/A2/A3/A4	78-81	Kokusan	<b>634-617</b>

## Suzuki Street

AC50R	1971	ND	<b>634-401</b>
AS50R	1971	ND	<b>634-401</b>
MT50R/J/K	71-73	ND	<b>634-401</b>
TS50R	1971	ND	<b>634-401</b>
TS75M/A/B Colt	75-77	ND	<b>634-401</b>
TC90/R/J	70-72	Kokusan	<b>634-501</b>
TC90/R/J	70-72	ND	<b>634-402</b>
TS90/R/J	70-72	Kokusan	<b>634-501</b>
TS90/R/J	70-72	ND	<b>634-402</b>
TC100K/L/M/A/B Blazer	73-77	Kokusan	<b>634-501</b>
TC100K/L/M/A/B Blazer	73-77	ND	<b>634-402</b>
TS100K/L/M/A/B Honcho	73-77	Kokusan	<b>634-501</b>
TS100K/L/M/A/B Honcho	73-77	ND	<b>634-402</b>

# Ignition Tune-Up Kits

## Suzuki Street

Model	Year	Ignition	Ignition Kit
RV125K/L/M/A/B Tracker	73-77	ND	634-402
TC125J/K/L/M/A/B Prospector	72-77	ND	634-402
TS125R/J/K/L/M/A/B Duster	71-77	ND	634-402
S32-150cc	1968	ND	_____
S32-2-150cc	1968	ND	_____
GT185K/L/M Adventurer	73-75	ND	_____
GT250K/L/M/A/B	73-77	Kokusan	634-504
T305	1969	Kokusan	634-505
TC305	1969	Kokusan	634-505
T350	69-70	Kokusan	634-505
T350R/J	71-72	Kokusan	634-505
GT380J/K/L/M/A/B Sebring	72-77	ND	634-403
GT380J/K/L/M/A/B Sebring	72-77	Kokusan	_____
T5001/2/3	68-70	Kokusan	634-505
T500R/J/K/L/M Titan	71-75	Kokusan	634-505
GS550B	1977	ND	634-407
GS550B/C/EC/N/EN	77-79	Kokusan	634-507
GS550LN	1979	Kokusan	634-507
GT550J/K/L/M/A/B Indy	72-77	ND	634-404
GT550J/K/L/M/A/B Indy	72-77	Kokusan	634-503
GS750B	1977	Kokusan	634-507
GS750B/C/EC/N/EN	77-79	ND	634-407
GS750LN	1979	ND	634-407
GT750J/K/L/M/A/B Sebring	72-77	ND	634-404
GS850GN	1979	ND	634-407
GS1000C/EC/N/EN	78-79	ND	634-407
GS1000LN	1979	ND	634-407
GS1000SN	1979	ND	634-407

## Suzuki Dual Sport & Offroad

MT50R/J/K	71-73	ND	634-401
TS50R	1971	ND	634-401
TM75L/M/A	74-76	ND	634-401
TS75M/A/B Colt	75-77	ND	634-401
RV90J/K/L/M Rover	72-75	ND	634-401
RV90M/A/B Rover	75-77	ND	634-402
TC90/R/J	70-72	Kokusan	634-501
TC90/R/J	70-72	ND	634-402
TS90/R/J	70-72	Kokusan	634-501
TS90/R/J	70-72	ND	634-402
TC100K/L/M/A/B Blazer	73-77	Kokusan	634-501
TC100K/L/M/A/B Blazer	73-77	ND	634-402
TS100K/L/M/A/B Honcho	73-77	Kokusan	634-501
TS100K/L/M/A/B Honcho	73-77	ND	634-402
RV125K/L/M/A/B Tracker	73-77	ND	634-402
TC125K/L/M/A/B Prospector	73-77	ND	634-402
TS125R/J/K/L/M/A/B Duster	71-77	ND	634-402

## Yamaha Street

RD60/A/B	73-75	Hitachi	634-206
U7E-70	1969	Hitachi	634-208
HT1-90	1970	Hitachi	634-206
HT1B-90	1971	Hitachi	634-210
RD250/A/B	73-75	Mitsubishi	634-204
RD350/A/B	73-75	Mitsubishi	634-204
RD400C/D/E	1978-on	Mitsubishi	634-225
TX500/A	73-74	Hitachi	634-232
XS500B/C/D/E	75-78	Hitachi	634-232
XT500C/D/E/F Dual Sport	76-79	ND	634-226
XS1/XS1B/XS2-650	70-72	Hitachi	634-201
TX650/A	73-74	Hitachi	634-201
XS650B/C/D/E/F/2F	75-79	Hitachi	634-201
XS650SE/SF Special	78-79	Hitachi	634-201
TX750/A	73-74	Hitachi	_____
XS750D/2D	1977	Hitachi	634-228

## Yamaha Dual Sport & Offroad

Model	Year	Ignition	Ignition Kit
YZ50G	1980	Mitsubishi	634-230
JT1/JT1L-60 Mini Enduro	1971	Hitachi	634-206
JT2/JT2MX-60	1972	Hitachi	634-206
GT1-80	1973	Hitachi	634-206
GT80/A/B/C	73-76	Hitachi	634-206
GT80E/F	78-79	Hitachi	634-206
GTMX/GTMXA/GTMXB-80	73-75	Mitsubishi	634-207
GTMXC/GTMXD-80	76-77	Mitsubishi	634-207
GTMXE/GTMXF-80	78-79	Mitsubishi	634-230
MX80G/H/J	80-82	Mitsubishi	634-230
TY80A Trials	74-75	Mitsubishi	634-231
YZ80A/B/C/D/E	74-78	Mitsubishi	634-207
HT1-90	1970	Hitachi	634-206
HT1B-90	1971	Hitachi	634-210
HT1BM-90	1971	Hitachi	634-210
DT100A/B	74-75	Mitsubishi	634-231
DT100C/D	76-77	Mitsubishi	634-230
LT2/LT3-100 Enduro	72-73	Hitachi	634-210
LT2M/LTMX-100	72-73	Hitachi	634-210
MX100A/B	74-75	Hitachi	634-206
MX100F	1979	Mitsubishi	634-230
AT1E/AT1B/AT1C-125	69-71	Hitachi	634-206
AT2M-125/AT2MX-125	1972	Hitachi	634-210
AT2/AT3-125	72-73	Hitachi	634-210
DT125A/B/C	74-76	Hitachi	634-208
DT125E	1978	Mitsubishi	634-230
MX125A/B	74-75	Hitachi	634-206
CT1/CT1B/CT1C-175 Enduro	69-71	Hitachi	634-206
CT2/CT3-175 Enduro	72-73	Hitachi	634-210
DT175A/B/C Dual Purpose	74-76	Hitachi	634-211
TY175B/C Trials	75-76	Hitachi	634-221
DT1-250 Enduro	1968	Mitsubishi	634-203
DT1B/DT1C-250 Enduro	69-70	Mitsubishi	634-203
DT1S-250 Enduro	1969	Mitsubishi	634-203
DT1E-250 Enduro	1971	Mitsubishi	634-203
DT1C-MX250/DT1MX-250	70-71	Mitsubishi	634-203
DT2/DT3-250	72-73	Mitsubishi	634-203
DT250A/B/C/D/E	74-78	Mitsubishi	634-212
TY250A Trials	1974	Hitachi	634-221
TY250C/D Trials	76-77	Hitachi	634-221
RT1/RT1B-360 Enduro	70-71	Mitsubishi	634-203
RT2/RT3-360 Enduro	72-73	Mitsubishi	634-203
RT1MX/RT1B-MX360	70-71	Mitsubishi	634-203
TT500C/D/E/F	76-79	ND	634-226
XT500C/D/E/F Dual Sport	76-79	ND	634-226



634-611 Kawasaki Z1-900

# Contact Breaker Plate Assy. & Ignition Contact Points

VINTAGE

INTAKE

ENGINE

SUSPENSION

CONTROL

ELECTRICAL

CHEMICAL

TOOLS

WATERCRAFT

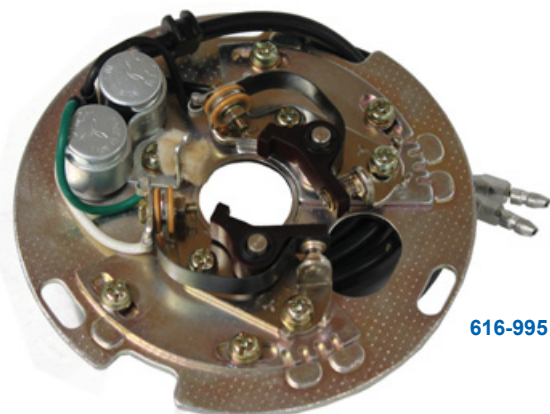

616-995



616-010



616-009



616-013



616-014

## Sudco Contact Breaker Plate Assemblies

Includes mounting plate, contact points, and condensers.  
**Made in Japan.**

### Honda

OEM Reference	30200-300-154	Order No.	616-990
Model		Year	
CB750K0/K1-K5		69-75	
CB750K		76-78	

### Kawasaki

OEM Reference	21135-011	Order No.	616-995
Model		Year	
Z1/A/B-900		73-75	
KZ900A4/A5		76-77	
KZ900B1 LTD		1976	
KZ1000A1/A2/A2A		77-78	
KZ1000B1/B2/B3 LTD		77-79	
KZ1000C1/C1A/C2		78-79	
KZ1000D1 Z1R		1978	



## PJ1 Super Cleaner

Multi-application, non-residue, evaporating degreaser

- High pressure blasts
- Powerful solvent melts oil, carbon, grease and grime away
- Dries quickly, displaces moisture and leaves no residue

Sold in California Compliant 13 fl. oz. aerosol can.

Order No. **899-081**

## Sudco Ignition Contact Points

OEM Daichi brand replacements. Sold each.  
**Made in Japan.**

### Honda

Hitachi Ignition	OEM Reference	Order No.
	30202-041-015	616-001
	30202-147-008	

NA50 Express II	79-80		
NC50 Express	77-80		
Z50AK0/AK1-AK6 Mini Trail	68-75		
Z50A	76-78		
Z50R	79-87		
Z50RD	1986		
ATC70/K1	73-74		
ATC70	78-85	XL75	77-79
CL70/K1/K2/K3 Scrambler70	69-73	XR75K0/K1/K2	73-75
CT70K0 Trail 70	69-71	XR75	76-78
CT70 Trail 70	76-82	XL80S	80-85
CT70HK0/HK1 Trail 70H	70-73	XR80	79-84
CT70K1/K2/K3/K4 Trail 70	72-75	XR80R	85-88
SL70K0/K1 Moto Sport	71-73	XR80R	90-91
XL70K0/K1	74-75	XR100	81-84
XL70	1976	XR100R	85-88
		XR100R	90-91



Nippondenso Ignition	OEM Reference	Order No.
	30202-107-004	616-002
	30202-216-004	

ATC90/K1/K2/K3	70-75		
ATC90	76-78		
CM91	66-69		
CL90 Scrambler	67-69		
CT90K0 Trail 90	66-68		
CT90K1-K6 Trail 90	69-75		
CT90 Trail 90	76-79		
S90 Super 90	64-69	XL125	74-77
SL90 Motosport 90	1969	CA175 (CD175) Touring 175	68-69
ST90K0/K1/K2 Trail Sport 90	73-75	CA175K3 Touring 175	69-70
CB100K0/K1/K2 Super Sport	70-72	CB175K3 Super Sport	1969
CL100K0/K1/K2 Scrambler	70-72	CB175K4-K7 Super Sport	70-73
CL100S Scrambler	1973	CL175K0 Scrambler	68-69
SL100/K1/K2/K3 Moto Sport	70-73	CL175K3 Scrambler	69-70
XL100/K1	74-76	CL175K4-K7 Scrambler	70-73
ATC110	79-80	SL175K0/K1 Motosport 175	70-72
CB125S/S1/S2/S	73-76	XL175/K1/K2	73-75
CL125S/S1 Scrambler	73-74	CB200	1974
CT125 Trail 125	1977	CB200T	75-76
SL125/K1/K2 Moto Sport	71-73	CL200	1974
TL125K0/K1/K2 Trials	73-75	TL250 Trials	75-76
TL125S Trials	1976	XL250/K1/K2 Moto Sport	72-76
		XL350K0/K1	74-75



# Ignition Contact Points

## Honda

Nippondenso Ignition	OEM Reference	Order No.
Right Side	30203-268-004	<b>616-003</b>
Left Side	30204-268-004	<b>616-004</b>

CB72 Hawk 250	61-68
CL72 Scrambler 250r	62-65
CB77 Super Hawk 305	61-68
CL77 Scrambler 305	65-68

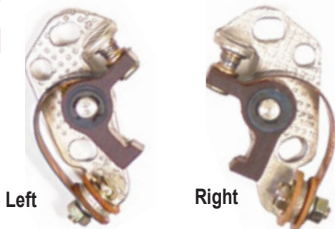

Left Right

Nippondenso Ignition	OEM Reference	Order No.
Right Side	30203-286-004	<b>616-005</b>
Left Side	30204-286-004	<b>616-006</b>

CB350G (2-cylinder)	1973
CB350K0/K1-K4 Super Sport	68-73
CL350K0/K1-K5 Scrambler	68-73
SL350/K1/K2 Moto Sport	70-72
CB360/G	1974
CB360T	75-76
CJ360T	76-77
CL360/K1 Scrambler	74-75

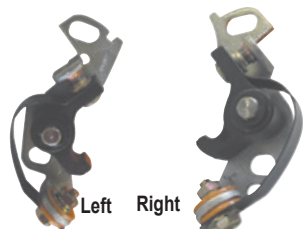

Left Right

Hitachi Ignition	OEM Reference	Order No.
Right Side	30203-300-154	<b>616-009</b>
	30203-300-005	
Left Side	30204-300-154	<b>616-010</b>
	30204-300-005	

CB500/K1/K2	71-73
CB550F Super Sport	75-77
CB550K/K1	74-75
CB550K	76-78
CB750A Automatic	76-78
CB750K0/K1-K5	69-75
CB750K	76-78
CB750F Super Sport	75-78



Left Right

Kokusan Ignition	OEM Reference	Order No.
	30202-028-003	<b>616-011</b>

CL90 Scrambler	67-69
CM91	66-69
CT90K0 Trail 90	66-68
CT90K1-K6 Trail 90	69-75
CT90 Trail 90	76-79
S90 Super 90	64-69
SL90 Motosport 90	1969



Kokusan Ignition	OEM Reference	Order No.
	30202-003-003	

CA102 (50cc)	62-69
CA200 (90cc)	63-66
CT200 (90cc) Trail 90	64-66
CL125A Scrambler	67-69
SS125A Super Sport	67-69



## Honda

Nippondenso Ignition	OEM Reference	Order No.
Right Side	30203-333-004	<b>616-013</b>
Left Side	30204-333-004	<b>616-014</b>

CB350F/F1 Super Sport	72-74
CB400F Super Sport	75-77

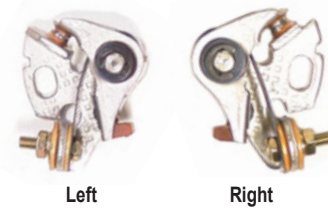

Left Right

Hitachi Ignition	OEM Reference	Order No.
	30202-216-005	

CA175 (CD175)Touring 175	68-69
CA175K3 Touring 175	69-70
CB175K3 Super Sport	1969
CB175K4-K7 Super Sport	70-73
CL175K0 Scrambler	68-69
CL175K3 Scrambler	69-70
CL175K4-K7 Scrambler	70-73
SL175K0/K1 Motosport 175	70-72
CB200	1974
CB200T	75-76
CL200	1974



Kokusan Ignition	OEM Reference	Order No.
Right Side	30203-292-003	<b>616-017</b>
Left Side	30204-292-003	<b>616-018</b>

CB450K0/K1-K7 Super Sport	65-74
CL450K0/K1-K7 Scrambler	68-74
CB500T	75-76
GL1000 Goldwing	75-79
GL1000L Goldwing LTD	1975

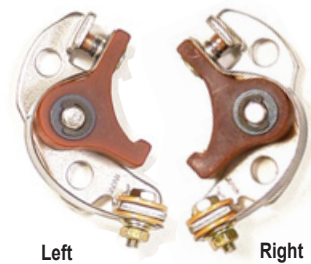

Left Right

Kokusan Ignition	OEM Reference	Order No.
	30210-357-003	

CR250M/M1 Elsinore	73-75
CR250M Elsinore	1976



	OEM Reference	Order No.
	30202-063-004	<b>616-021</b>
	30202-044-000	

P50 Moped	67-68
PC50 Moped	69-70
QA50/K1K2/K3	70-75



Nippondenso Ignition	OEM Reference	Order No.
	30200-358-004	<b>616-407</b>

MR250 Elsinore	1976
MT250K0/K1 Elsinore	74-75
MT250K Elsinore	1976



## Honda

Hitachi Ignition	OEM Reference	Order No.
	30202-122-004	<b>616-850</b>

PA50I Moped	78-79	
PA50II Moped	78-80	



Nippondenso Ignition	OEM Reference	Order No.
	30202-131-004	

MR50/K1 Elsinore	74-75	
NA50 Express II	79-80	
NC50 Express	77-80	



Nippondenso Ignition	OEM Reference	Order No.
	30202-041-315	<b>616-853</b>
	30202-041-305	
	30202-041-004	
	30202-171-004	

CT70	80-82	
FL250 Odyssey	77-80	



## Kawasaki

Kokusan Ignition	OEM Reference	Order No.
	21008-019	<b>616-603</b>

F81M-250	1971	
F11M-250	1973	
S1A/S1B/S1C-250	73-75	
KH250A5	1976	
S2/S2A-350	72-73	
S3/S3A-400	74-75	



Kokusan Ignition	OEM Reference	Order No.
	21008-006	<b>616-604</b>
	21008-020	

KD80/A2	75-76	
KD80M1-M8	80-88	
G3SS/A/B/C/D-90	69-74	
G3TR-90	69-70	
MC1/A/B-90	73-75	
MC1M/MC1MA-90	74-75	
G3SSE-100	1975	
G3TRA-100	1971	
G4TRA/B/C/D/E-100	70-75	
G5/A/B/C-100	72-75	
KD100M1/M2/M3/M4	76-79	
KE100A5/A6/A7/A8/A9/A10	76-81	
KE100B1-B14	82-95	
KH100B7/B8	76-77	
KM100A1-A7	76-81	
KV100A7	1976	
KD125/A2/A3/A4/A5	75-79	
KE125A3-A9	76-82	
KS125/A	74-75	
F11/A/B-250	73-75	



## Kawasaki

Mitsubishi Ignition	OEM Reference	Order No.
	21008-002	<b>616-605</b>

D1-100	66-68	
MT1/MT1A/MT1B/MT1C-75	71-75	
C2SS-120	67-69	
C2TR-120	67-69	



Mitsubishi Ignition	OEM Reference	Order No.
	21008-018	<b>616-606</b>

F6/A/B-125 Enduro	71-73	
B1/B1L/B1LPA-125	1966	
B1T/B1TL-125	66-69	



Nippondenso Ignition	OEM Reference	Order No.
	21008-025	<b>616-608</b>
	21008-023	

KZ400A1/A2	77-78	
KZ400/D//D3/D4	74-77	
KZ400S/S2/S3 Special	75-77	
KZ750B1/B2 2-cyl.	76-77	



Mitsubishi Ignition	OEM Reference	Order No.
	21082-007	<b>616-610</b>

H1B-500	1972	
---------	------	--



Kokusan Ignition	OEM Reference	Order No.
	21008-027	<b>616-612</b>

KZ400B1/B2	78-79	
KZ400C1	1978	
KZ400H1 LTD	1979	
KZ440A1 LTD	1980	
KZ440B1	1980	
KZ440D1 LTD Belt	1980	
KZ750B3/B4 (2-cylinder)	78-79	
KZ750G1 LTD (2-cylinder)	1980	



Kokusan Ignition	OEM Reference	Order No.
	21008-1002	<b>616-614</b>

KLT200A1	1981	
KZ200A1/A1A/A2	78-79	
KL250A1/A1A/A2	78-79	
KZ250D1	1980	



# Ignition Contact Points

## Kawasaki

Kokusai Ignition	OEM Reference	Order No.
Left Side	21008-027	<b>616-612</b>
Right Side	21008-028	<b>616-613</b>

KZ550A1	1980
KZ650B1/B2/B2A/B3	77-79
KZ650C1/C2/C3 Custom	77-79
KZ650D1/D1A/D2 SR	78-79
KZ650E1 LTD	1980
KZ650F1	1980
Z1A/B-900	73-75
KZ900A4/A5	76-77
KZ900B1 LTD	1976
KZ1000A1/A2/A2A	77-78
KZ1000B1/B2/B3 LTD	77-79
KZ1000C1/C1A/C2	78-79
KZ1000D1 Z1R	1978



## Suzuki

Nippondenso Ignition	OEM Reference	Order No.
Left Side	33172-36210	<b>616-013</b>
Right Side	31440-36210	<b>616-014</b>

GS550B	1977
GS750B/C/EC/N/EN	77-79
GS750LN	1979
GS850GN	1979
GS1000C/EC/N/EN	78-79
GS1000LN	1979
GS1000SN	1979



Nippondenso Ignition	OEM Reference	Order No.
	31460-09010 LH	<b>616-404</b>
	31440-09010 RH	

S32-150	1968
GT185K/L/M/A/B	73-77
TC185L/M/A/B Ranger	74-77
T10-250	63-64

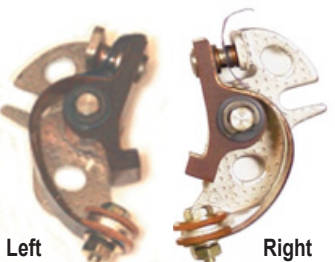

Nippondenso Ignition	OEM Reference	Order No.
Left Side	31460-11010	<b>616-405</b>
Right Side	31440-11010	<b>616-403</b>

T200	65-68
TC200	65-68
T20-250 X6	65-69
T250	1969
TC250	1969



## Suzuki

Nippondenso Ignition	OEM Reference	Order No.
	32240-03010	<b>616-406</b>
	32240-43012	

F50R Moped	1971
------------	------



Nippondenso Ignition	OEM Reference	Order No.
	32240-43012	<b>616-407</b>
	32240-28010	
	32240-12010	
	32240-20010	

AC50 Maverick	1971
AS50 Scrambler	1971
MT50R/J/K	71-73
TS50R/J/K/L	70-73
RV90J/K/L/M/A/B	72-77
TC90/R/J	70-72
TS90/R/J	70-72
TC100K/L/M/A/B Blazer	73-77
TS100K/L/M/A/B Honcho	73-77
T125II/R	69-70
TC125J/K/L/M/A/B Prospector	72-77
RV125K/L/M/A/B Tracker	73-77



Nippondenso Ignition	OEM Reference	Order No.
Center	33160-31010	<b>616-409</b>
Left Side	33170-31010	<b>616-412</b>
Right Side	33170-31010	<b>616-412</b>



GT550J/K/L/M/A/B Indy	72-77
GT750J/K/L/M/A/B Lemans	72-77

Nippondenso Ignition	OEM Reference	Order No.
Center	33160-33010	<b>616-410</b>
Left Side	33170-33010	<b>616-413</b>
Right Side	33170-33010	<b>616-413</b>

GT380J/K/L/M/A/B Sebring	72-77
--------------------------	-------





## Suzuki

Nippondenso Ignition	OEM Reference	Order No.
Left Side	31140-36210	<b>616-419</b>
	33160-44010	
Right Side	33140-44010	<b>616-418</b>

GS400B/XB 1977

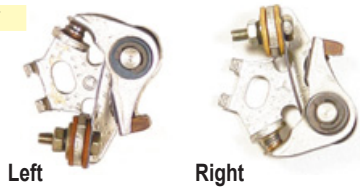

Kokusan Ignition	OEM Reference	Order No.
Center	33170-34020	<b>616-501</b>
Left Side	33160-34020	<b>616-502</b>
Right Side	33160-34020	<b>616-502</b>

GT550J/K/L/M/A/B Indy 72-77



Kokusan Ignition	OEM Reference	Order No.
	31440-15020	<b>616-503</b>
	33172-33020	

GT250K/L/M/A/B Hustler 73-77 RH only  
GT380J/K/L/M/A/B Sebring 72-77 Center only



Kokusan Ignition	OEM Reference	Order No.
	31440-15020	<b>616-603</b>

T125II	1971	
T125R	1971	
GT250K/L/M/A/B	73-77 LH only	
T250II	1970 LH & RH	
T250R/J	71-72 LH & RH	
T305	1969 LH & RH	
TC305	1969 LH & RH	
T350-1/2/R/J	69-72 LH & RH	T5001/2/3 68-70 LH & RH
GT380J/K/L/M/A/B	72-77 LH & RH	T500R/J/K/L/M Titan71-75 LH & RH



## Suzuki

Kokusan Ignition	OEM Reference	Order No.
	32240-07610	<b>616-604</b>
	32240-12020	

TC90/R	70-71
TS90/R	70-71
TC100K/L/M/A/B	73-77
TS100K/L/M/A/B	73-77
TS250/II	69-70



Kokusan Ignition	OEM Reference	Order No.
	33160-44110 LH	<b>616-612</b>
	33160-45020	
	33140-44110 RH	<b>616-613</b>
	33140-45020	

GS400B/XB/C/XC	77-78
GS425N/EN	1979
GS425LN	1979
GS550B/C/EC/N/EN	77-79
GS550LN	1979



Kokusan Ignition	OEM Reference	Order No.
	32240-04420	<b>616-862</b>

JR50C/N/T/X/Z 78-82



Nippondenso Ignition	OEM Reference	Order No.
	32240-43012	<b>616-860</b>

RM50C/N/T	78-80
TS50J/K/L	72-74
DS80C/N/T/X/Z	78-82
DS100C/N/T	78-80
TS100C/N	78-79
DS125N/T	79-80
TS125C/N	78-79



Nippondenso Ignition	OEM Reference	Order No.
	32240-07022	<b>616-861</b>

B100	65-67
B105P	65-67
KT120	65-67
TC120	1971
TC120II	1971
TC120R	1971
TS250/II Savage	69-70



# Ignition Contact Points

## Yamaha

Mitsubishi Ignition	OEM Reference	Order No.
	2A6-81321-20-00	616-001
	437-81321-20-00, 434-81321-10-00	
	2F5-81321-20-00, 1K8-81321-20-00	
YZ50G	1980	
GTMXE/GTMXF-80	78-79	
LB80-2AC/2AD/2AE	76-78	
LB80-2HC/3D	76-77	
MX80G/H/J	80-82	
TY80A/B Trials	74-75	
RS100B/C	75-76	
DT100A/B/C/D/E/F	74-79	
MX100F	1978	TY175B/C Trials 75-76
DT125E/F	78-79	TY250A Trials 1974
AG175 (farm bike)	1974	TY250C/D Trials 76-77



Nippondenso Ignition	OEM Reference	Order No.
	583-81621-50-00	616-002

TT500C/D/E/F	76-79
XT500C/D/E/F	76-79



Hitachi Ignition	OEM Reference	Order No.
Left Side	1J7-81621-10-00	616-010
Right Side	1J7-81622-10-00	616-220



XS750D/2D	1977	Left	Right
-----------	------	------	-------

Hitachi Ignition	OEM Reference	Order No.
	132-81221-10-00	

YL1/YL1E-100	66-67
AS2C-125	1969
YA6-125	1966
YAS1C-125	1968
YCS1/YCS1C-180	1968
CS3C-200	1970
AT1E/AT1B/AT1C-125	69-71



Hitachi Ignition	OEM Reference	Order No.
	207-81221-90-00	616-202
	207-81321-11-00	
	207-81321-10-00	

JT1/JT1L-60 Mini	1971
JT2/JT2MX-60	1972
RD60/A/B	73-75
GT1-80/GT80A/B/C/D/E/F	73-79
GTMX/GTMXA-80	73-74
HT1-90	1970
HT1B-90	1971
HT1BM-90	1971
LT2/LT3-100 Enduro	72-73
LT2M/LTMX-100	72-73
MX100A/B	74-75
AT1M/AT1MB/AT1-MX125	69-71
AT2M-125	1972
AT2MX-125	1972



AT2/AT3-125 Enduro	72-73
MX125A/B	74-75
CT1/CT1B/CT1C-175 Enduro	69-71
CT2/CT3-175 Enduro	72-73

## Yamaha

Mitsubishi Ignition	OEM Reference	Order No.
	1M1-81321-20-00	616-203
	214-81321-20-00	
RT1/RT1B-360 Enduro	70-71	
RT2/RT3-360 Enduro	72-73	
RT1MX/RT1B-MX360	70-71	
DT1/DT1B/DT1C-250 Enduro	68-70	
DT1S-250 Enduro	1969	
DT1E-250 Enduro	1971	
DT1C-MX250/DT1MX-250	70-71	
DT2/DT3-250	72-73	
DT250A/B/C/D/	74-78	



Mitsubishi Ignition	OEM Reference	Order No.
	120-81321-90-00	616-204
	120-81321-20-00	

YG5S-75	1969
G6S/GS6B/G7S-75	70-72



Mitsubishi Ignition	OEM Reference	Order No.
Left Side	278-81621-20-00	616-207
Right Side	278-81622-20-00	616-207

DS7-250	1972
RD250/A/B	73-75
R5/B/C-350	70-72
RD350/A/B	73-75



Hitachi Ignition	OEM Reference	Order No.
	256-81621-11-00	616-209

XS1/XS1B/XS2-650	70-72
TX650/A	73-74
XS650B/C/D/E/F/2F	75-79
XS650SE/SF	78-79
TX750/A	73-74



Hitachi Ignition	OEM Reference	Order No.
Right Side	371-81622-10-00	616-210
Left Side	371-81621-10-00	616-211

TX500/A	73-74
XS500B/C/D/E	75-78



Right Left

Mitsubishi Ignition	OEM Reference	Order No.
	1V1-81321-90-00	616-212
	1V1-81321-20-00, 296-81321-21-00	

GTMX/GTMXA/GTMXB-80	73-75
GTMXC/GTMXD-80	76-77
YZ80A/B/C/D	74-77



## Yamaha

Hitachi Ignition	OEM Reference	Order No.
	183-81421-19-00	<b>616-213</b>
	183-81421-10-00	

U7E-70	1969
HS1/HS1B-90	70-71
LS2-100	1972
AS2C-125 eng 025702	1969
DT125A/B/C	74-76
RD125B/C	75-76
YAS1C-125	1968
RD200A/B/C - LH & RH	74-76



Mitsubishi Ignition	OEM Reference	Order No.
	1M1-81321-20-00	<b>616-214</b>
	438-81321-20-00	

DT250A/B/C/D/E	74-78
----------------	-------



Hitachi Ignition	OEM Reference	Order No.
	443-81321-10-00	<b>616-215</b>

DT175A/B/C Dual Purpose	74-76
-------------------------	-------



Mitsubishi Ignition	OEM Reference	Order No.
	1A0-81621-20-00	<b>616-216</b>

RD400C/D/E	76-78
------------	-------



Nippondenso Ignition	OEM Reference	Order No.
Right Side	1L9-81621-51-00	<b>616-217</b>
	1L9-81621-50-00	
Left Side	1L9-81622-50-00	<b>616-218</b>
	1L9-81622-50-00	

XS360C/D/2D	76-77
XS400D/E/2E/F/2F	77-79



Right

Left

## BSA, Matchless, Norton, Triumph

OEM Reference	Order No.
54415803	<b>616-900</b>

CC	Applications	Year
736	Matchless Interceptor	67-68
500	Matchless Major G80	64-65
650	Matchless Swift G12	65-66
350	Norton 50MK	65-
500	Norton ES2MK	
750	Norton P11	67-68
200	Triumph T20SC	63-
200	Triumph T20	63-64



## BSA, Enfield, Matchless, Norton, Triumph

OEM Reference	Order No.
54419827	<b>616-901</b>

750	Matchless	1968
	Norton P11	1968-
250	BSA	68-70
500	BSA A50	68-70
650	BSA A65	68-70
736	Enfield	68-70
750	Norton	68-70
250	Triumph	68-70



500	Triumph Tiger	68-70
250	Triumph	68-70
650	Triumph Trophy	68-70

## Hodaka

Kokusan Ignition	OEM Reference	Order No.
	943016	<b>616-604</b>

100 Road Toad
125 Wombat



## Triumph

OEM Reference	Order No.
60600271	<b>616-800</b>

Bonneville	73-78
------------	-------



OEM Reference	Order No.
5449828	<b>616-801</b>

Trident TR6/7	69-76
---------------	-------

# Condensers

## Sudco Condensers

OEM Daichi brand replacements. Sold each.  
**Made in Japan.**

### Honda

Hitachi Ignition	OEM Reference	Order No.
	30250-042-005	<b>617-001</b>

Z50AK0/AK1-AK6 Mini Trail	68-75		
Z50A	76-78		
Z50R	79-87		
Z50RD SpecialQ	1986		
ATC70/K1	73-74		
ATC70	78-85		
CT70K0 Trail 70	69-71		
CT70 Trail 70	76-82		
CT70HK0/HK1 Trail 70H	70-73		
CT70K1/K2/K3/K4 Trail 70	72-75	XL75	77-79
SL70K0/K1 Moto Sport	71-73	XR75K0/K1/K2	73-75
XL70K0/K1	74-75	XR75	76-78
XL70	1976	XL80S	80-85



Nippondenso Ignition	OEM Reference	Order No.
	30250-107-000	<b>617-002</b>
	30250-330-003	

CB100K0/K1/K2 Super Sport	70-72		
CL100K0/K1/K2 Scrambler	70-72		
CL100S Scrambler	1973		
SL100/K1/K2/K3 Moto Sport	70-73		
XL100/K1	74-76		
CB125S/S1/S2/S	73-76		
CB125S	1978		
CL125S/S1 Scrambler	73-74		
SL125/K1/K2 Moto Sport	71-73		



Hitachi, Kokusan & Nippondenso Ignition	OEM Reference	Order No.
	30280-216-000	<b>617-006</b>

CA160 Touring 160	66-69		
CB160 Sport 160	65-69		
CL160 Scrambler	66-67		



Nippondenso Ignition	OEM Reference	Order No.
	30250-333-004	<b>617-007</b>

CB350F/F1 Super Sport	73-74		
CB400F Super Sport	75-77		



Nippondenso & Kokusan Ignition	OEM Reference	Order No.
	30250-028-000	<b>617-008</b>

CL90 Scrambler	67-69		
S90 Super 90	64-69		



### Honda

Kokusan Ignition	OEM Reference	Order No.
	30250-001-013	<b>617-009</b>

C100 (50cc) Super Cub	59-62		
CA100 (50cc)	62-70		



Nippondenso Ignition	OEM Reference	Order No.
	30250-268-024	<b>No Longer Available</b>
	30250-268-014	
	30250-268-004	

CB72 Hawk 250	61-66		
CL72 Scrambler	62-65		
CB77 Scrambler 305	65-68		



Nippondenso Ignition	OEM Reference	Order No.
	30250-273-000	

CB72 Hawk 250	61-66		
CL72 Scrambler	62-65		
CB77 Super Hawk 305	61-68		
CL77 Scrambler	65-68		



Nippondenso Ignition	OEM Reference	Order No.
	30250-273-003	
	30250-362-000	

XL175/K1/K2	73-75		
-------------	-------	--	--



Nippondenso Ignition	OEM Reference	Order No.
	30280-237-154	
	30280-237-005	

CA175K3 Touring 175	69-70		
CB175K4-K7 Super Sport	70-73		
CL175K4-K7 Scrambler	70-73		
SL175K0/K1 Motorsport	70-72		
CB200	1974		
CB200T	75-76		
CL200	1974		



Nippondenso Ignition	OEM Reference	Order No.
	30280-286-701	<b>617-015</b>

Japan domestic model single point 350			
CB350			
CB450			



## Honda

Hitachi Ignition	OEM Reference	Order No.
	30280-235-000	617-016

CB175K3	1969
CL175K0 Scrambler	68-69
CL175K3	1969



Nippondenso Ignition	OEM Reference	Order No.
	30250-369-004	617-017

CB360/G	1974
CB360T	75-76
CJ360T	76-77
CL360/K1 Scrambler	74-75



Nippondenso Ignition	OEM Reference	Order No.
	30250-052-000	617-018

ATC90/K1/K2/K3	70-75
ATC90	76-78
CM91	66-69
CT90	66-68
CT90K0 Trail 90	66-68
CT90K1-K6 Trail 90	69-75
CT90 Trail 90	76-79
FL250 Odyssey	77-80



Kokusan Ignition	OEM Reference	Order No.
	30280-292-672	617-020
	30280-371-000	

CB350G Super Sport 350 2-cyl.	1973
CB350K0/K1-K4 Super Sport 2-cyl	68-73
CL350K0/K1-K5 Scrambler 350	68-73
SL350/K1/K2 Moto Sport	69-73
CB450K0 Super Sport	65-68
CB450K1-K7 Super Sport	68-74
CL450K1-K6 Scrambler	68-74
CB500T	75-76
GL1000 Goldwing	75-79
GL1000L Goldwing LTD	1976



Hitachi Ignition	OEM Reference	Order No.
	30250-300-005	617-022
	30250-300-154	

CB500/K1/K2	71-73
CB550F Super Sport	75-77
CB550K/K1	74-75
CB550/K	76-78
CB750A Automatic	76-78
CB750F Super Sport	75-78
CB750K0	69-70
CB750K1-K5	70-75
CB750K	76-78



## Honda

Kokusan Ignition	OEM Reference	Order No.
	30280-357-003	617-023

CR250M/M1 Elsinore	73-75
CR250M	1976



Hitachi Ignition	OEM Reference	Order No.
	30250-035-005	617-024
	30250-041-005	

Z50AK0/AK1-AK6 Mini Trail	68-75
Z50A	76-78
Z50R	79-87
Z50RD SpecialQ	1986
ATC70/K1	73-74
ATC70	78-85
CT70K0 Trail 70	69-71
CT70 Trail 70	76-82
CT70HK0/HK1 Trail 70H	70-73
CT70K1/K2/K3/K4 Trail 70	72-75
SL70K0/K1 Moto Sport	71-73
XL70K0/K1	74-75



Mitsubishi Ignition	OEM Reference	Order No.
	30250-035-006	617-025

S65 Sport 65	65-69
CT70 Trail 70	80-82
CT70HK0/HK1 Trail 70H	70-73
SL70K0/K1 Moto Sport	71-73
XL70K0/K1	74-75



Nippondenso Ignition	OEM Reference	Order No.
	30250-329-305	617-027

MT125K0/K1 Elsinore	74-75
MT125 Elsinore	1976
XL250/K1/K2 Moto Sport	72-76
MT250K0/K1 Elsinore	74-76
XL350K0/K1	74-75
XL350	76-78



Nippondenso Ignition	OEM Reference	Order No.
	30250-402-010	617-850

CM185T Twinstar	78-79
-----------------	-------



Kokusan Ignition	OEM Reference	Order No.
	30250-436-000	617-851

XL100S	79-80
--------	-------



# Condensers

## Honda

Nippondenso Ignition	OEM Reference	Order No.
	30250-041-004	617-852
	30250-035-003	

S65 Sport 65	65-69
CT70	80-82



Kokusan & Nippondenso Ignition	OEM Reference	Order No.
	30250-074-003	617-853
	30250-035-003	

SL90	1969
------	------



	OEM Reference	Order No.
	30254-402-701	617-854
	30250-035-003	

CM200T Twinstar	1980
-----------------	------



## Kawasaki

Kokusan Ignition	OEM Reference	Order No.
	21013-029	617-601

Z1/A/B-900	73-75
------------	-------



Kokusan Ignition	OEM Reference	Order No.
	21013-026	617-602

S1A/S1B/S1C-250	73-75
KH250A5	1976
S2/S2A-350	72-73
S3/S3A-400	74-75



Kokusan Ignition	OEM Reference	Order No.
	21013-006	617-603

KD80/A2	75-76		
KD80M1-M8	80-88		
G3SS/A/B/C/D-90	69-74		
G3TR-90	69-70		
MC1/A/B-90	73-75		
MC1M/MC1MA-90	74-75		
G3SSE-100	1975		
G3TRA-100	1971	KH100B7/B8	76-77
G4TRA/B/C/D/E-100	70-75	KM100A1-A7	76-81
G5/A/B/C-100	72-75	KV100A7	1976
KD100M1/M2/M3/M4	76-79	KD125/A2/A3/A4/A5	75-79
KE100A5/A6/A7/A8/A9/A10	76-81	KE125A3-A9	76-82
KE100B1-B14	82-95	KS125/A	74-75



## Kawasaki

Mitsubishi Ignition	OEM Reference	Order No.
	21013-001	617-604

D1-100	66-68
MT1/MT1A/MT1B/MT1C-75 Mini	71-75
C2SS-120	67-69
C2TR-120	67-69

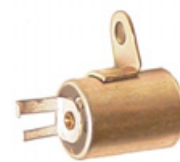

Mitsubishi Ignition	OEM Reference	Order No.
	21013-023	617-605

F6/A/B-125 Enduro	71-73
-------------------	-------



Mitsubishi Ignition	OEM Reference	Order No.
	21013-015	617-606

H1B-500 Mach III	1972
------------------	------



Kokusan Ignition	OEM Reference	Order No.
	21013-030	617-607
	21013-022	

F8/F8A-250	71-72
F11/A/B-250	73-75



Nippondenso Ignition	OEM Reference	Order No.
	21013-031	617-608

KZ400A1/A2	77-78
KZ400/D//D3/D4	74-77
KZ400S/S2/S3 Special	75-77



Nippondenso Ignition	OEM Reference	Order No.
	21013-034	617-609

KZ400A1/A2	77-78
KZ400/D//D3/D4	74-77
KZ400S/S2/S3 Special	75-77
KZ750B1/B2 2-cyl	76-77



## Kawasaki

Kokusan Ignition	OEM Reference	Order No.
	21013-037	<b>617-611</b>

KZ550A1	1980
KZ650B1/B2/B2A/B3	77-79
KZ650C1/C2/C3 Custom	77-79
KZ650D1/D1A/D2 SR	78-79
KZ650E1 LTD	1980
KZ650F1	1980



Kokusan Ignition	OEM Reference	Order No.
	21013-033	<b>617-612</b>

KV75A5/A6	75-76
-----------	-------



Kokusan Ignition	OEM Reference	Order No.
	21013-036	<b>617-613</b>

KLT200A1	1981
KZ200A1/A1A/A2	78-79
KL250A1/A1A/A2	78-79
KZ250D1	1980



Kokusan Ignition	OEM Reference	Order No.
	21013-1004	<b>617-614</b>

KZ400B1/B2	78-79
KZ400C1	1978
KZ400H1 LTD	1979
KZ440A1 LTD	1980
KZ440B1	1980
KZ440D1 LTD Belt	1980

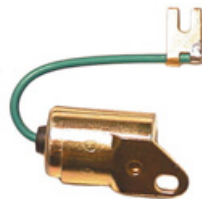

Kokusan Ignition	OEM Reference	Order No.
	21013-035	<b>617-615</b>

Z1/A/B-900	73-75
KZ900A4/A5	76-77
KZ900B1 LTD	1976
KZ1000A1/A2/A2A	77-78
KZ1000B1/B2/B3 LTD	77-79
KZ1000C1/C1A/C2 Police	78-79
KZ1000D1 Z1R	1978



## Suzuki

Nippondenso Ignition	OEM Reference	Order No.
	33241-02030	<b>617-401</b>
	33241-12130, 31641-01310	

A100	1969
AC100	1969



## Suzuki

Kokusan Ignition	OEM Reference	Order No.
Right Side	31641-11011	<b>617-402</b>
Left Side - <b>Not available</b>	31642-11011	

T200 RH only	65-68
TC200 RH only	65-68
T20	1969
TC250	1969



Nippondenso Ignition	OEM Reference	Order No.
	31440-11010	<b>617-403</b>

T125II	70-71
T125R	70-71



Nippondenso Ignition	OEM Reference	Order No.
	31642-09010	<b>617-404</b>

S32-150	1968
TC185L/M/A/B Ranger	74-77
T10-250	63-64



Nippondenso Ignition	OEM Reference	Order No.
Right Side	31642-09010	<b>617-404</b>
Left Side	31641-09010	<b>617-406</b>

GT185K/L/M	73-75
------------	-------



Nippondenso Ignition	OEM Reference	Order No.
Right Side	32341-03110	<b>617-407</b>

AC50 Maverick	1971
AS50 Scrambler	1971
MT50R/J/K	71-73
F50R Moped	1971
TS50R/J/K/L	71-74
TM75L/M/A	74-76
TS75M/A/B Colt	75-77
RV90J/K/L	72-74
RV90M	1975



Nippondenso Ignition	OEM Reference	Order No.
	31241-12011	<b>617-408</b>
	31241-12010	

RV90M	1975
RV90A/B	76-77
TC90/R/J	70-72
TS90/R/J	70-72
A100A/B Gopher	76-77
TC100K/L/M/A/B Blazer	73-77
TS100K/L/M/A/B Honcho	73-77
RV125K/L/M/A/B Tracker	73-77
TC125J/K/L/M/A/B Prospector	72-77
TS125R/J/K/L/M/A/B Duster	71-77



# Condensers

## Suzuki

Nippondenso Ignition	OEM Reference	Order No.
	33261-33010 32341-31010	<b>617-409</b>
GS550B/C/EC/N/EN	77-79	
GT550J/K/L/M/A/B	72-77	
GS750B/C/EC/N/EN	77-79	
GS750LN	1979	
GT750 J/K/L/M/A/B	72-77	
GS850GN	1979	
GS1000C/EC/N/EN	78-79	
GS1000LN/SN	1979	



Nippondenso Ignition	OEM Reference	Order No.
	33261-38010	<b>617-410</b>

GT380J/K/L/M/A/B	72-77
------------------	-------



Kokusan Ignition	OEM Reference	Order No.
Left Side	32341-34020	<b>617-501</b>
Center	32342-34020	
Right Side	32343-34020	

GT550J/K/L/M/A/B	72-77
------------------	-------

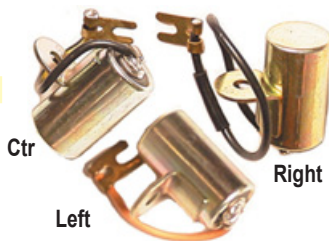

Nippondenso Ignition	OEM Reference	Order No.
Left Side	33261-33020	<b>617-504</b>
Center	33262-33020	<b>617-505</b>
Right Side	33263-33020	<b>617-506</b>

GT380J/K/L/M/A/B	72-77
------------------	-------

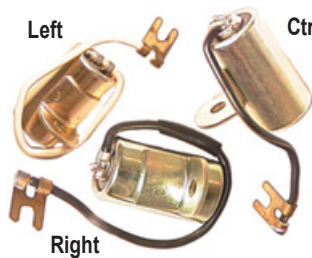

Kokusan Ignition	OEM Reference	Order No.
	32341-25890 32342-12021	<b>617-507</b>

TC90/R/J	70-72
TS90/R/J	70-72
TC100K/L/M/A/B	73-77
TS100K/L/M/A/B Honcho	73-77
TS250/II Savage	69-70



## Suzuki

Kokusan Ignition	OEM Reference	Order No.
Right Side	31641-18522 31641-18521, 31641-15021 31641-18520	<b>617-508</b>
Left Side	31642-18522 31642-18521, 31642-15022, 31642-15021	<b>617-509</b>

GT250K/L/M/A/B	73-77
T250II	1970
T250R/J	71-72
T305	1969
TC305	1969
T350	69-70
T350-1/2/R/J	69-72
T5001/2/3	68-70
T500R/J/K/L/M Titan	71-75

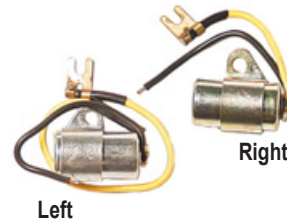

Nippondenso Ignition	OEM Reference	Order No.
Left Side	31641-09010	<b>617-510</b>
Right Side	31642-09010	<b>617-404</b>



GT185A/B	76-77
----------	-------

Nippondenso Ignition	OEM Reference	Order No.
	31641-09010	<b>617-510</b>

S32-150	1968
S32-2-150	1968
TC185L/M/A/B Ranger	74-77



Kokusan Ignition	OEM Reference	Order No.
	32341-07020	<b>617-511</b>

B100	65-67
B105P	65-67
KT120	65-67
TC120	1971
TC120II	1971
TC120R	1971
TS250/II Savage	69-70



Kokusan Ignition	OEM Reference	Order No.
	33261-45020	<b>617-610</b>

GS550B/C/EC/N/EN	77-79
GS550LN	1979
GS750B	1977

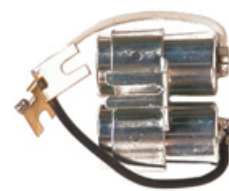



## Suzuki

Kokusan Ignition	OEM Reference	Order No.
	32341-26030	<b>617-860</b>

OR50N/T	79-80	
---------	-------	--



Kokusan Ignition	OEM Reference	Order No.
	32341-04020	<b>617-861</b>

JR50C/N/T/X/Z	78-82	
---------------	-------	--



## Triumph

	OEM Reference	Order No.
	54420128	<b>617-800</b>

Bonneville	68-78	
Trident	68-72	



## Yamaha

Hitachi Ignition	OEM Reference	Order No.
Left Side	278-81625-91-00	<b>617-201</b>
	132-81225-10-00	
Right Side	278-81626-91-00	<b>617-202</b>
	132-81226-10-00	

YL1/YL1E-100	66-67	
YCS1/YCS1C-180	1968	
CS5-200	1972	
RD200A/B/C	74-76	

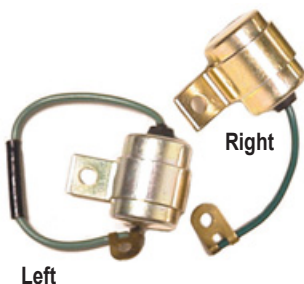

Mitsubishi Ignition	OEM Reference	Order No.
	214-81326-90-00	<b>617-203</b>
	214-81326-20-00	

DT1C/DT1E-MX250	70-71	
DT1/DT1B/DT1C-250 Enduro	68-70	
DT1S-250 Enduro	1969	
DT1E-250 Enduro	1971	
DT2/DT3-250	72-73	
DT250A/B/C/D/E	74-78	
RT1/RT1B/RT2/RT3-360	70-73	
Enduro		
RT1M/RT1MX-360	70-71	



## Yamaha

Mitsubishi Ignition	OEM Reference	Order No.
Right Side	169-81125-20-00	<b>617-204</b>
Left Side	169-81126-21-00	<b>617-205</b>

DS6B/DSC6 -250	69-70	
YDS5-250	1967	
YM2C-350	1966	



Hitachi Ignition	OEM Reference	Order No.
	207-81326-90-00	<b>617-206</b>
	207-81326-10-00	

JT1/JT1L-60 Mini	1971		
JT2/JT2MX-60	1972		
RD60/A/B	73-75		
GT1/GT80A/B/C	73-76		
GT80E/F	78-79		
HT1-90	1970	AT1MX-125	1971
MX100A/B	74-75	MX125A/B	74-75
AT1-E125	1969	CT1/CT1B/CT1C-175	69-71
AT1B/AT1C-125	70-71	TY175B/C Trials	75-76
AT1M-125	1969	TY250A Trials	1974
AT1MB-MX125	1970	TY250C/D Trials	76-77



Hitachi Ignition	OEM Reference	Order No.
	207-81326-90-00	<b>617-209</b>

XS1/XS1B/XS2-650	70-72	
TX650/A	73-74	
XS650B/C/D/E/F/2F	75-79	
XS650SE/SF Special	78-79	



Mitsubishi Ignition	OEM Reference	Order No.
	360-81625-90-00	<b>617-210</b>
	360-81625-20-00	

RD250/A/B	73-75	
RD350/A/B	73-75	
RD400C/D/E/F	76-79	

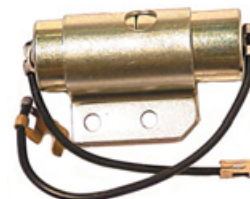

# Condensers

## Yamaha

Mitsubishi Ignition	OEM Reference	Order No.
	296-81325-90-00	<b>617-211</b>
	296-81325-20-00	

YG1/YG1K/YG1T/YG1TK-60	63-66
YJ1/YJ1K/YJ2/YJ2S-60	64-65
YG5S-75	1969
GTMX/GTMXA/GTMXB-80	73-75
GTMXC/GTMXD-80	76-77
TY80A/B Trials	74-75
YZ80A/B/C/D	74-77
DT100A/B	74-75
RS100B	1975



## Yamaha

Hitachi Ignition	OEM Reference	Order No.
	296-81325-90-00	<b>617-216</b>
	296-81325-20-00	

XS750D/2D	1977
-----------	------



Hitachi Ignition	OEM Reference	Order No.
	341-81625-10-00	

TX750/A	73-74
---------	-------



Hitachi Ignition	OEM Reference	Order No.
	278-81625-91-00	<b>617-212</b>
	278-81625-90-00,	
	278-81625-20-00, 148-81126-10-00	

U7E-70	1969
YA6-125	1966
DT125A/B/C	74-76
DS7-250 LH only	1972
R5/B/C-350 LH only	70-72



Mitsubishi Ignition	OEM Reference	Order No.
	1K8-81325-20-00	<b>617-219</b>
	511-81325-20-00	

LB50PE/PF/PG/PH/PJ	78-82
YZ50G	1980
GTMXE/GTMXF-80	78-79
LB80-2AC/2AD/2AE	76-78
LB80-2HC	1976
LB80-3D	1977
MX80G/H/J	80-82
DT100C/D	76-77
MX100F	1979



Hitachi Ignition	OEM Reference	Order No.
	371-81625-10-00	<b>617-213</b>

TX500/A	73-74
XS500B/C/D/E	75-78



RS100C	1976
DT125E	1978

Hitachi Ignition	OEM Reference	Order No.
	277-81326-10-00	<b>617-214</b>
	277-81326-90-00	

HT1B/HT1BM-90	1971
LT2/LT3-100	72-73
LT2M/LTMX-100	72-73
AT2/AT3-125	72-73
AT2M-125/ATMX-125	72-73
CT2/CT3-175 Enduro	72-73
DT175A/B/C	74-76



Hitachi Ignition	OEM Reference	Order No.
	371-81625-10-00	<b>617-215</b>

DT250A/B/C/D/E	74-78
----------------	-------



## Yamaha

Nippondenso	OEM Reference	Order No.
	583-81625-50-00	617-222

XT500C/D/E/F Dual Sport	76-79
TT500C/D/E/F	76-79



Mitsubishi Ignition	OEM Reference	Order No.
Left side only for models listed. Right side not available.	168-81226-20-00	617-224

R3-350	1969
YR1	1968
YR2-350	1968
YR2C-350	1968



## Yamaha

Mitsubishi Ignition	OEM Reference	Order No.
	2F5-81325-20-00	617-870
	2F5-81325-90-00	

DT100E/F	78-79
DT125F	1979



Mitsubishi Ignition	OEM Reference	Order No.
	2F5-81325-20-00	617-871

HS1/HS1B-90	70-71
LS2-100	1972
AS2C-125	1969
RD125B/C	75-76
YAS1C-125	1968
CS3B-200	1971
CS3C-250	1970



Yamaha RT1-360

# Stators



615-600



615-152

## Rick's Motorsport Electrics Stators

Direct bolt-on replacement stators with all connectors. A high quality, cost effective alternative to the OEM unit. Sold each.

### Honda Street

Model	Year	Order No.
VT600C Shadow VLX OK	88-89	615-603
CB750C Custom	80-82	615-600
CB750F Super Sport	79-82	615-600
CB750K	79-82	615-600
CB750L LTD	1979	615-600
CB750SC Nighthawk	82-83	615-600
CB900C Custom	80-82	615-600
CB900F Super Sport	81-82	615-600
CB1000C Custom	1983	615-600
CB1100F Super Sport	1983	615-600
GL1100 Goldwing	80-83	615-601
GL1100A Goldwing Aspencade	82-83	615-601
GL1100I Goldwing Interstate	80-83	615-601
GL1200 Goldwing	1984	615-601
GL1200A Goldwing Aspencade	84-87	615-601
GL1200I Goldwing Interstate	84-87	615-601
GL1200L Goldwing LTD	1985	615-608
GL1200L Goldwing SEI	1986	615-608

### Kawasaki Street

ZX600G1/G2 Ninja ZX-6R	98-99	615-623
KZ1000A3/A3A/A4 MKII	79-80	————
KZ1000B3/B4 LTD	79-80	————
KZ1000C2 Police	1979	————
KZ-1000D3 Z1R	1980	————
KZ1000E1/E2 Shaft ST	79-80	————
KZ1000J1/J2/J3	81-83	————
KZ1000K1/K2 LTD	81-82	————
KZ1000M1/M2 CSR	81-82	————
KZ1000P1-P20 Police	82-01	————
KZ1000R1/R2 Replica	82-83	————
KZ1100A1/A2/A3 Shaft	81-82	————
KZ1100B1/B2 GPz	81-82	————
KZ1100D1/D2 Spectre	82-83	————
KZ1100L1 LTD Shaft	1983	————
ZN1100B1/B2 LTD Shaft	84-85	————
ZX1100A1/A2 GPz	83-84	————

## Suzuki Street

Model	Year	Order No.
GS550ED/ESD	1983	615-643
GS550ES3/ESE/EF/ESF/ESG	83-86	615-643
GS550LD	1983	615-643
GS550LF/LG	85-86	615-643

## Yamaha Street

XZ550RJ/RK Vision	82-83	615-652
FZR600W/WC/AC	89-90	615-655
FZR600RA/RAC-RL/RLC	90-99	615-655
XV700SC/CSC/CT/CTC Virago	86-87	615-650
XV700SS/SSC Virago	1986	615-650
XV750U/UC-K/KC Virago	88-98	615-650
XV1100S/SC-K/KC Virago	86-98	615-650
XV1000SH/SHC Virago 1100 Special	1996	615-650
XV1100SJ/SJCC Virago 1100 Special	1997	615-650
XV1100SK/SKC Virago 1100 Special	1998	615-650
VMX12N/NC/S/SC V-Max	85-86	615-654
VMX12U/UC-N/NC V-Max	88-01	615-654
XVZ12 Venture & Venture Royale	83-85	615-654
XVZ13 Venture & Venture Royale	86-93	615-654

## Yamaha ATV

YFM350ERT Moto-4	1987	615-682
YFM350ERU/ERW Moto-4	88-89	615-680
YFM350ERA Moto-4	1990	615-681
YFM350ERD/ERE/ERF Moto-4	92-94	615-681
YFM350FWT Big Bear 4WD	1987	615-682
YFM350FWU/FWW Big Bear 4WD	88-89	615-680
YFM350FWA/FWB/FWD Big Bear 4WD	90-92	615-681
YFM350FWE/FWF Big Bear 4WD	93-94	615-681
YFM350XT Warrior	1987	615-682
YFM350XU/XW Warrior	88-89	615-680
YFM350XA/XB/XD/XE/XF/XG Warrior	90-95	615-681



## Kawasaki Stator

Direct bolt-on replacement stator for Kawasaki Z1/KZ900 & KZ1000 models with all connectors. Sold each.

Order No. [615-150](#)

## Kawasaki Street

Model	Year
Z1/A/B-900	73-75
KZ900A4/A5	76-77
KZ900B1 LTD	1976
KZ1000A1/A2/A2A	77-78
KZ1000B1/B2 LTD	77-78
KZ1000C1/C1A Police	1978
KZ1000D1 Z1R	1978

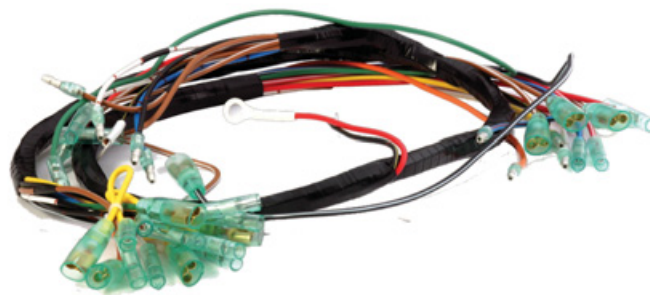

## Kawasaki Main Wiring Harness

Replica of the original wiring harness. Available for the following models:

## Kawasaki Street

Model	Year	Order No.
H1/H1A/H1B-500	69-71	<a href="#">900-120</a>
H2/H2A-750	72-73	<a href="#">900-121</a>
KZ900A4/A5	76-77	<a href="#">900-125</a>
KZ900B1 LTD	1976	<a href="#">900-125</a>
Z1/Z1A/Z1B-900	73-75	<a href="#">900-123</a>
KZ1000A1/A2/A2A	77-78	<a href="#">900-124</a>



## 7 Way Crimping Tool (CT-1)

- Incorporates wire cutter, terminal crimper and wire stripper into one handy tool
- Black anodized finish with insulated hand grips
- Crimp slot on end of tool secures most ignition terminals including "W" type, right angle and "High-Tower" terminals
- Crimps 7mm to 8.5mm ignition wire
- Works with 10 to 22 gauge solderless terminals
- **WARNING** - Disconnect power source before using this tool.

Order No. [618-999](#)

# Ignition Switches



900-453



900-454



900-456



900-455



900-451



900-450

## Ignition Switches

Designed as OEM replacements. Switches are direct plug-in to the wiring harness and no soldering or crimping required. Two keys included with each switch. Sold each.

### Honda

#### Flat Key CBR/VF Switch Order No. 900-453

Model	Year
VF500F Interceptor	84-86
CBR600F Hurricane	87-90
VF700C Magna	84-86
VF750C Magna	82-83
VF750S Sabre	82-83
VF750F Interceptor	83-84
CBR1000F Hurricane	87-88
VF1000F Interceptor	1984

#### Flat Key 5-Prong base with accessory position Order No. 900-454

CB400F Super Sport	1977
CB550K	77-78
CB550F Super Sport	77-78
CB650	79-82
CB650C Custom	79-82
CB750A Automatic	77-79
CB750K	77-79
CB750L LTD	1979
CB750C Custom	79-82
CB750F Super Sport	79-82
CB750SC Nighthawk	82-83
CB900C Custom	80-82
CB900F Super Sport	80-82
CBX1000	79-80
GL1000	76-77

#### Flat Key with round end plug Order No. 900-456

All CB/CL175/350/450/750

#### Flat Key with square end plug Order No. 900-455

All CB500/550/750

### Kawasaki

#### Flat Key - Late model KZ1000/1100 Switch Order No. 900-451

EX250F2/F3/F4 Ninja 250r	88-90
EX250F6/F7/F8 Ninja 250R	92-94
EX500A1/A2/A3/A4/A5/A6/A7	87-93
KZ550A3/A4	82-83
KZ550C3/C4 LTD	82-83
KZ550F1/F2 Spectre & LTD	83-84
KZ550M1 LTD	1983

Continue model listing on next column

### Kawasaki

#### Flat Key - Late model KZ1000/1100 Switch Order No. 900-451

Model	Year
ZX550A1/A2 GPz	84-85
ZX600A1/A2/A3 Ninja 600	85-87
ZX600B1 Ninja 600 RX	1987
ZX600C1~C6 Ninja 600R	88-93
KZ650H1/H2/H3 CSR	81-83
KZ700A1	1984
KZ750E1/E2/E3	80-82
KZ750F1 LTD	1983
KZ750H1/H2/H3/H4 LTD	80-83
KZ750L3	1983
KZ750M1 CSR Twin	1982
KZ750N1/N2 Spectre	82-83
KZ750R1 GPz	1982
ZX750A1/A2/A3 GPz	83-85
ZX750E1/E2 GPz Turbo	84-85
ZX750F1/F2/F3/F4 Ninja 750R	87-90
ZX900A1/A2/A3 Ninja	84-86
KZ1000E1/E2 Shaft ST	79-80
KZ1000P Police	82-93
KZ1000R2 Replica	1983
KZ1100A3 Shaft	1983
KZ1100B2 GPz	1982
KZ1100D2 Spectre	1983
KZ1100L1 LTD	1983
ZX1100A1/A2 GPz	83-84

#### Flat Key - Early model KZ900/1000/ Switch Order No. 900-450

(Fits both four and six prong plug connectors)	
KZ650B1/B2/B2A/B3	77-79
KZ650C1/C2/C3 Custom	77-79
KZ650D1/D2 SR	78-79
KZ650E1/F1	1980
KZ750B1/B2/B3/B4 (2 cylinder)	76-79
KZ750G1 LTD (2 cylinder)	1980
Z1/A/B-900	73-75
KZ900A4/A5	76-77
KZ900B1 LTD	1976
KZ1000A1/A2	77-78
KZ1000A3/A3A/A4 MK II	79-80
KZ1000B1/B2/B3/B4 LTD	77-80
KZ1000C1/C1A/C2/C3/C4 Police	78-81
KZ1000D1 ZIR	1978
KZ1000D3 ZIR	1980



900-461



900-462



900-465

## Suzuki

Flat Key Switch GSXR/GSF	Order No. 900-460
Model	Year
GSF600ST/SV/SW Bandit	96-98
GSX-R600V	1997
GSX-R750WR/WS	94-95
GSX-R750T/V	96-97
TL1000SV	1997
GSX-R1100WS/WT/WV/WW	95-98
GSF1200SV/SAV/SW/SAW Bandit	97-98

Flat Key Switch	Order No. 900-461
GSF400M/N/P Bandit	91-93
GS500EK-EW	89-98
GSX600FJ-FV Katana	88-97
GSX-R600WN/WP	92-93
RF600RR/RS/RT	94-96
GSX750FK-FV Katana	89-97
GSXR-750J/K/L/M/N	88-92
GSX-R750WP	1993
VX800I/M/N	90-93
RF900RR/ RS/ RT/ RV	94-97
RF900RZS	1995
GSX1100GM/GN/GP Shaft	91-93
GSXR-1100K/L/M/N	89-92
GSXR1100WP/ WR	93-94

Flat Key Switch	Order No. 900-462
GS450ET/EX/EZ	80-82
GS450LT /LX/LZ/LD	80-83
GS450ST/SX	80-81
GS450TX/TZ/TXZ/TXD	81-83
GS550B/C/EC/N/EN/ET	77-80
GS550LN/LT/LX/LZ	79-82
GS550TX	1981
GS550MZ Katana	1982
GS650EX/EZ	81-82
GS650GX/GZ/GD	81-83
GS650GLX/GLZ/GLD	81-83
GS650MD Katana	1983
GS750C/EC/N/EN	78-79
GS750LN/LT/LX	80-81
GS850GLT/GLX/GLZ/GLD	80-83
GS1000LN/SN	1979
GS1000GLT/GLX	80-81
GS1100EZ/ED	82-83
GS1100GLZ/GLD	82-83
GS1100LT	1980

## Yamaha

Flat Key Switch	Order No. 900-465
Model	Year
SR250G/H/J Exciter	80-82
SR250TH Exciter II	80-82
SRX250T/TC	1987
XS400H Special II	1981
XS400SH/SJ Heritage Special	81-82
XS400RJ/RK Seca	82-83
XV500K Virago	1983
XJ550H/J/K Maxim	81-83
XJ550RH/RJ/RK Seca	81-83
FJ600L/LC/N/NC	84-85
FZ600S/SC/T/TC/U/UC	86-88
FZR600W/WC/AC	89-90
FZR600RA/RAC/RB/RBC/RD/RDC	90-92
FZR600RE/REC/RF/RFC/RG/RGC	93-95
FZR600RH/RHC/RJ/RJC	96-97
XJ600SD/SDC/SE/SEC Seca II	92-93
XJ650G/H/J/K Maxim	80-83
XJ650LH Midnight Maxim	1981
XJ650RJ Seca	1982
XS650H Special II	1981
XS650SH Special	1981
XS650SJ/SK Heritage Special II	82-83
FZ700T/TC	1987
FZ750N/S/SC	85-86
FZ750U/UC	1988
FZR750RT/RU	87-88
XJ750K Maxim	1983
XJ750MK Midnight Maxim	1983
XS750SE/SF	78-79
XV750H/J/K Virago	82-83
XV750MK Midnight Virago	1983
XS850LH/SH Special	1981
XJ900RK Seca	1983
XV920RH/RJ Euro Virago only (chain drive)	81-82
<b>Does not fit 1983 XV920MK Midnight and XV920J/K 82-83</b>	
FZR1000T/TC/U/UC	87-88
FZR1000W/WC/A/AC/B/BC	89-91
FZR1000D/DC/E/EC	92-93
FJ1100L/LC/N/NC	84-85
FJ1200S/SC/T/TC	86-87
FJ1200W/WC/A/AC/B/BC/D/DC	89-92
FJ1200AD/ADC/AE/AEC (ABS)	92-93

# Turn Signals & Turn Signal Stems



721-001



721-002



## OEM Style Replacement Turn Signals

Designed as OEM replacements. Sold each.

### Honda

Model	Year	Front	Rear
CB350K0/K1/K2/K3/K4	68-73	721-001	721-002
CB400F Super Sport	75-77	721-005	721-006
CB500T	75-76	721-005	721-006
CX500C Custom	79-82	721-005	721-006
CX500D Deluxe	79-81	721-005	721-006
CB550F Super Sport	75-77	721-005	721-006
CB750K0/K1/K2/K3/K4	69-74	721-001	721-002
CB900 C Custom	80-82	721-005	721-006
CB1100F Supersport	1983	721-021	721-022
CBX1000	81-82	721-015	721-016

### Kawasaki

KZ200A1/A2	78-79	721-634	721-633
KZ250D1/D2/L1/W1	80-83	721-634	721-633
S1/KH250	73-78	721-633	721-633
KZ305A1/A2B1-B3	81-82	721-634	721-633
KZ305A1/A2B1-B3	87-88	721-634	721-633
S2-350 2-stroke triple	1972	721-601	721-601
S2A-350 2-stroke triple	1973	721-633	721-633
S3-400	74-75	721-633	721-633
KH400 A5	78-79	721-633	721-633
KZ400A1/A2	77-78	721-601	721-601
KZ440A3-A4/D2-D5	82-84	721-634	721-633
H1D/H1E/H1F	73-75	721-633	721-633
KH500A8	1976	721-633	721-633
KZ550C1-C4/F2/M1	80-84	721-634	721-633
KZ550D1, H2-H3 GPz	81-83	721-621	—
KZ650B1	1977	721-601	721-601
KZ650D1/D2/H1-H3	78-79	721-634	721-633
KZ650D1/D2/H1-H3	81-83	721-634	721-633
KZ700A1	1984	721-621	—
KZ750F1/H1-H4/M1	80-83	721-634	721-633
KZ750L3	1983	721-621	—
KZ750R1 GPz	1982	721-621	—
H2B/C-750 Mach IV	74-75	721-601	721-601
KZ750B1/B2 2-cyl	76-77	721-601	721-601
Z1/A/B-900	73-75	721-601	721-601
KZ900A4/A5	76-77	721-601	721-601
KZ900B1 LTD	1976	721-601	721-601
KZ900B1	81-82	721-633	—
KZ1000A1	1977	721-601	721-601
KZ1000A3/A3A/A4 MK11	79-80	721-631	721-632
KZ1000B1-B4/K1/K2	77-82	721-634	—
KZ1000D1 Z1R	1978	721-611	721-612
KZ1000D3 Z1R	1980	721-611	721-612
KZ1000J1/J2/J3	81-83	721-621	721-622
KZ1000R1-R2 (ELR)	82-83	721-621	—
KZ1100B1-B2	81-82	721-621	—
KZ1100L1	1983	721-634	721-633

### Suzuki

GS1000C/EC/N/EN	78-79	721-401	721-402
-----------------	-------	---------	---------

## Universal Turn Signals

D.O.T. approved for USA and "E" European approved. Heavy duty flexible stem is suitable for Street, Dual Sport and Scooters. Mounting is universal with wiring to fit most models. Sold in pairs.

Order No. 721-700



721-906

721-907

## OEM Style Turn Signal Stems

Designed as OEM replacements. Sold each.

### Honda

Model	Year	Front	Rear
CB750K0/K1/K2/K3/K4	69-74	721-906	721-907
CB1100F Super Sport	1983	721-905	721-905

### Kawasaki

KZ550A1/A2	80-81	721-902	721-902
Z1/A/B-900 (Long)(STD)	73-75	721-900	721-900
Z1/A/B-900 (Short)	73-75	721-901	721-901
KZ1000A3/A3A/A4 MK11	79-80	721-902	721-902



## Kawasaki Front Turn Signal Stems

Replica front turn signal stems, fit 1972-73 H2-750, and 1972 S2-350 sold as a pair. OEM part number 23051-047.

Order No. 721-909



## Kawasaki H2-750 Rear Turn Signal Stem

Replica of the stock turn signal stem. Sold each.

Order No. 721-908





## Kawasaki H2-750 Front Turn Signal Stay Brackets

Replica of the H2-750 1972-1973 front turn signal stay brackets. Includes 2 dampers, and 2 brackets. OEM part number 23051-031 bracket and 44045-035 damper. Sold in pairs.

Order No. **721-925**



## Flasher Relay

Sold each. Fits the following Kawasaki models:

OEM Reference 27002-011 Order No. **951-050**

Model	Year
KH250A5	1976
S1A/S1B/S1C-250	73-75
S2A-350	1973
S3/S3A-400	74-75
KH400A3/A4/A5	76-78
H2B/H2C-750	74-75
Z1/Z1A/Z1B-900	73-75
KZ900A4/A5	76-77
KZ900B1 LTD	1976
KZ1000 (ALL)	77-83
KZ1100 (ALL)	81-83
KZ1300A	79-82



## DT1-250/RT1-360 Tail Light Lens

Sold each. Available for the following models:

Description	Order No.
Yamaha DT1-250 Tail Light Lens 168-84721-60-00	<b>722-700</b>
Yamaha RT1-360 Tail Light Lens	<b>722-702</b>



## Z1-900 Tail Light Lens

Sold each. Fits the following Kawasaki models:

OEM Reference 23026-023 Order No. **722-709**

Model	Year
G5-A/G5-B/G5-C100	73-75
KE100A5-A10	76-81
KH250A5	1976
S1A/S1B/S1C-250	73-75
S2A-350	1973
S3/S3A-400	74-75
KH400A3/A4/A5	76-78
H2B/H2C-750	74-75
Z1/Z1A/Z1B-900	73-75



## Z1R-1000 Tail Light Lens

Sold each. Fits the following Kawasaki models:

OEM Reference 23026-034 Order No. **722-708**

Model	Year
KZ550A1/A2/A3/A4	80-83
KZ550C1/C2 LTD	80-81
KZ550D1 GPz	1981
KZ650B1/B2/B2A/B3	77-79
KZ650C1/C2/C3	77-79
KZ650D1/D1A/D2 SR	78-79
KZ650E1 LTD	1980
KZ650F1	1980
KZ650H1 CSR	1981
KZ750B1/B2/B3/B4 (2-cylinder)	76-79
KZ750H1/H2 LTD	80-81
KZ900A4/A5	76-77
KZ900B1 LTD	1976
KZ1000A1/A2/A2A	77-78
KZ1000B1/B2/B3/B4 LTD	77-80
KZ1000D1 Z1R	1978
KZ1000D3 Z1R	1980

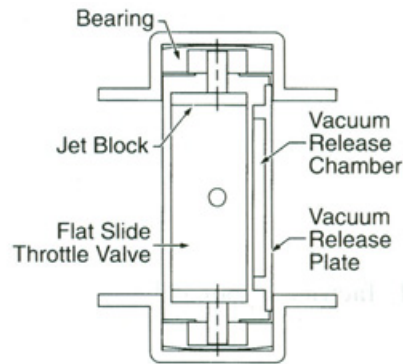

Revolutionary Throttle System -Top view of the throttle valve

## Keihin FCR (Flatslide CR) Racing Carburetors

Following in their tradition of high technology and performance, Keihin's latest carburetor design for racing is the FCR designed for downdraft engine design use. Features include a flatslide throttle operating on roller bearings with progressive linkage for smooth operation and control. Smoothbore venturi for maximum air flow. This is the ultimate racing carburetor for use on downdraft engines as found on many popular sportbikes destined for serious competition. Along with the highest level of technology available, the FCR's have proven there advantage with race wins around the world.

### Arctic Cat

Model	Year	Type	33mm Carb	33mm Carb Kit	35mm Carb	35mm Carb Kit	37mm Carb	37mm Carb Kit	39mm Carb	39mm Carb Kit	41mm Carb	41mm Carb Kit
DVX400		H	_____	_____	_____	_____	_____	_____	_____	016-855*	_____	016-856*

(DVX400 carb kits come with push/pull throttle)

### BMW

R-100R		H	_____	_____	_____	_____	016-694	_____	016-695	_____	_____	_____
--------	--	---	-------	-------	-------	-------	---------	-------	---------	-------	-------	-------

(Qt 2 carbs required for R-100R)

F-650 Dual		H	_____	_____	_____	_____	_____	_____	016-653	_____	_____	_____
------------	--	---	-------	-------	-------	-------	-------	-------	---------	-------	-------	-------

### Ducati

750SS Super Sport <b>Dual</b>	91-99	D	_____	_____	_____	_____	_____	_____	016-650	016-720*	016-670	016-721*
750SS Super Sport <b>Split</b>	All	D	_____	_____	_____	_____	_____	_____	016-687	016-746*	016-689	016-747*
900SS Super Sport <b>Dual</b>	91-99	D	_____	_____	_____	_____	_____	_____	016-650	016-720*	016-670	016-721*
900SS Super Sport <b>Split</b>	All	D	_____	_____	_____	_____	_____	_____	016-687	016-746*	016-689	016-747*
900SS Super Sport <b>Split</b>	All	D/H	_____	_____	_____	_____	_____	_____	_____	016-746A*	_____	016-747A*
900M Monster <b>Dual</b>	All	D	_____	_____	_____	_____	_____	_____	016-650	016-722*	016-670	016-723*
900M Monster <b>Split</b>	All	D	_____	_____	_____	_____	_____	_____	016-687	016-746*	016-689	016-747*
900M Monster <b>Split</b>	All	D/H	_____	_____	_____	_____	_____	_____	_____	016-746A*	_____	016-747A*

Note- 900SS/900M Split kits are available with two downdraft carburetor or one horizontal and one downdraft carburetor depending on manifold configuration. Aftermarket manifolds required for split kits.

### Harley Davidson®

Big Twin w/K&N Air Filter	90-04	H	_____	_____	_____	_____	_____	_____	_____	_____	016-699	016-755
Big Twin without Air Filter	90-04	H	_____	_____	_____	_____	_____	_____	_____	_____	016-699	016-756
XL883 Sportster	90-04	H	_____	_____	_____	_____	_____	_____	016-950	016-753	_____	_____
XL1200 Sportster	90-04	H	_____	_____	_____	_____	_____	_____	016-950	016-753	_____	_____

Use stock throttle cables for Harley-Davidson® models listed.

### Honda

XR250R		H	_____	_____	016-693	_____	_____	_____	_____	_____	_____	_____
TRX400EX	99 on	H	_____	_____	_____	_____	_____	_____	016-951	016-759*	016-960	016-761*

(TRX400EX carb kits come with push/pull throttle)

XR600R	89-00	H	_____	_____	_____	_____	_____	_____	_____	_____	016-961	016-730*
NT650 Hawk GT	88-91	H	_____	_____	_____	_____	_____	_____	_____	016-751*	_____	016-752*

(Qt 2 carbs required for NT650)

NX650	88-89	H	_____	_____	_____	_____	_____	_____	_____	_____	016-961	_____
XR650L w/o Choke Kit	93-07	H	_____	_____	_____	_____	_____	_____	_____	_____	016-781	016-749*
XR650L w/Choke Kit	93-07	H	_____	_____	_____	_____	_____	_____	_____	_____	016-799	016-749A
XR650R	00-07	H	_____	_____	_____	_____	_____	_____	_____	_____	016-962	016-765*



## Husaberg

Model	Year	Type	33mm Carb	33mm Carb Kit	35mm Carb	35mm Carb Kit	37mm Carb	37mm Carb Kit	39mm Carb	39mm Carb Kit	41mm Carb	41mm Carb Kit
FE501		H	---	---	---	---	---	---	---	---	016-963	016-872
FS650		H	---	---	---	---	---	---	---	---	016-963	016-873

## Kawasaki

KLX400 with choke	2003	H	---	---	---	---	---	---	016-798	016-864*	016-799	---
KLX400 no choke	2003	H	---	---	---	---	---	---	016-695	016-863*	016-781	---
<b>(all KLX400 and KSF400 carb kits come with push/pull throttle)</b>												
KSF400 (KXF400)	04-06	H	---	---	---	---	---	---	---	016-855*	---	016-856*
KLX650	93-96	H	---	---	---	---	---	---	---	---	016-963	016-868
<b>(KLX650 kit uses stock throttle and choke cable)</b>												
ZX750 Ninja ZX-7R	96-99	D	---	---	---	---	---	---	---	---	016-515	---
ZX900A Ninja 900R	84-86	H	---	---	---	---	---	---	016-500	---	---	---
ZX900B Ninja ZX-9R	98-99	D	---	---	---	---	---	---	---	---	016-590*	---
ZR1100	99-00	H	---	---	---	---	---	---	016-500	---	---	---
ZRX1200		H	---	---	---	---	---	---	016-500	---	---	---

See page 152 - 159 for more Carb Kits.

## Carb Kit Notes:

Type of Carburetor: **H** = Horizontal      **D** = Downdraft

+ Push/Pull cables required	Push/Pull Throttle only	021-280
	Push/Pull Throttle Cable	021-281
	Housing Length: 32"	
	or Push/Pull Throttle Cable	021-281.5
	Housing Length: 37", 5" longer than 021-281	

**Blue Part Numbers with asterisk\*** = Push/Pull cables included

**Blue Part Numbers** = Carb Only

**Red Part Numbers with asterisk\*** = Carb Kit complete with adapters and Motion Pro Push/Pull Cable Set if required

**Red Part Numbers** = Carb Kit with adapters

## Recommended Carburetor Size for Engine Displacement

Engine Displacement (cc)	Available FCR Carburetor (Venturi Diameter in mm)
400cc	33mm
600cc	33-35mm
750cc	35-39mm
1000cc and up	37-41mm

This is the recommended carburetor size for a 4-cylinder engine that is tuned for road race use. Stock engines should use the next smaller size and engine tuned to maximum output, may use one size larger.

**IMPORTANT:** Legal in California only for racing vehicles which may never be used upon a highway.

# KEIHIN FCR Carburetors

## KTM

Model	Year	Type	33mm Carb	33mm Carb Kit	35mm Carb	35mm Carb Kit	37mm Carb	37mm Carb Kit	39mm Carb	39mm Carb Kit	41mm Carb	41mm Carb Kit
LC4/RXC400 (97 to mid 00)		H	_____	_____	_____	_____	_____	_____	_____	016-740*	_____	_____
LC4/RXC400 (mid 00-06)		H	_____	_____	_____	_____	_____	_____	_____	016-740A	_____	_____
RXC/Duke 620 (94-mid 00)		H	_____	_____	_____	_____	_____	_____	_____	_____	016-963	016-739*
RXC/Duke 620 (00-mid 04)		H	_____	_____	_____	_____	_____	_____	_____	_____	016-963	016-739A*
950 Adventurer		D	_____	_____	_____	_____	_____	_____	_____	016-875*	_____	016-876*
950 Adventurer S		D	_____	_____	_____	_____	_____	_____	_____	016-875*	_____	016-876*
950 Super Enduro R		D	_____	_____	_____	_____	_____	_____	_____	016-875*	_____	016-876*

## Moto Guzzi

1100 Sport	94-96	H	_____	_____	_____	_____	_____	_____	_____	_____	_____	016-744*
------------	-------	---	-------	-------	-------	-------	-------	-------	-------	-------	-------	----------

## Norton

Commando 750/850 Dual		H	_____	_____	_____	016-860	_____	_____	_____	_____	_____	_____
-----------------------	--	---	-------	-------	-------	---------	-------	-------	-------	-------	-------	-------

Requires Amal MKII Conversion Manifolds.

## Suzuki

DR350	90-99	H	_____	_____	016-693	_____	_____	_____	_____	_____	_____	_____
DR-Z400E/S with choke	00-07	H	_____	_____	_____	_____	_____	_____	016-798	016-864*	016-799	_____
DR-Z400E/S no choke	00-07	H	_____	_____	_____	_____	_____	_____	016-695	016-863*	016-781	_____
DR-Z400SM w/choke	05-07	H	_____	_____	_____	_____	_____	_____	016-798	016-864*	016-799	_____
DR-Z400SM no choke	05-07	H	_____	_____	_____	_____	_____	_____	016-695	016-863*	016-781	_____
<b>(All DR-Z400 and LT-Z400 carb kits come with push/pull throttle)</b>												
LT-Z400 Quad	03-07	H	_____	_____	_____	_____	_____	_____	_____	016-855	_____	016-856*
SV650/S	99-02	D	_____	_____	_____	_____	_____	_____	_____	016-762*	_____	016-763*
GSX-R750 air cooled	to 92	H	_____	_____	_____	_____	_____	_____	016-498+	_____	016-508+	_____
(1100 Euro)		H	_____	_____	_____	_____	_____	_____	016-498+	_____	016-508+	_____
GSX-R750 liquid cooled	93-95	H	_____	_____	_____	_____	_____	_____	016-562*	_____	016-584*	_____
(1100 Euro)		H	_____	_____	_____	_____	_____	_____	016-562*	_____	016-584*	_____
GSX-R1100 air cooled	to 92	H	_____	_____	_____	_____	_____	_____	016-565+	_____	016-509+	_____
GSX-R1100W water	93-98	H	_____	_____	_____	_____	_____	_____	016-563*	_____	016-585*	_____

## Triumph

Speed Triple	94-99	H	_____	_____	_____	_____	_____	_____	016-716	_____	_____	_____
Bonneville/Thrupton	2001	H	_____	_____	_____	_____	_____	_____	016-654	016-877	_____	_____

Use stock throttle cables for Triumph models listed.

## Yamaha

SR500 with choke	79-81	H	_____	_____	_____	_____	_____	_____	016-798	_____	016-799	_____
SR500 no choke	79-81	H	_____	_____	_____	_____	_____	_____	016-696	_____	016-781	_____
YZF-R6 with TPS	99-02	D	_____	_____	016-524	_____	_____	_____	_____	_____	_____	_____
SRX600 Dual	1986	H	_____	_____	016-700	_____	_____	_____	016-652	_____	_____	_____
YFM660R Raptor	01-05	H	_____	_____	_____	_____	016-850*	_____	_____	016-851*	_____	_____
<b>(YFM660R carb kits come with push/pull throttle)</b>												
YXR660 Rhino	04-07	H	_____	_____	_____	_____	_____	_____	_____	_____	_____	016-866*
TDM850 Dual	92-93	D	_____	_____	_____	_____	_____	_____	_____	_____	016-671	016-735*
TRX850 Dual	All	D	_____	_____	_____	_____	_____	_____	_____	_____	016-671	016-735*
FZR750/1000		D	_____	_____	_____	_____	_____	_____	016-492	_____	_____	_____
YZF1000 with TPS	97	D	_____	_____	_____	_____	_____	_____	_____	_____	016-518*	_____
YZF-R1 with TPS	98-99	D	_____	_____	_____	_____	_____	_____	_____	_____	016-591*	_____

### Carb Kit Notes:

Type of Carburetor:	H = Horizontal	D = Downdraft
+ Push/Pull cables required	Push/Pull Throttle only	021-280
	Push/Pull Throttle Cable	021-281
	Housing Length: 32"	
	or Push/Pull Throttle Cable	021-281.5
	Housing Length: 37", 5" longer than 021-280	

### Carb Kit Notes:

Blue Part Numbers with asterisk* = Push/Pull cables included
Blue Part Numbers = Carb Only
Red Part Numbers with asterisk* = Carb Kit complete with adapters and Motion Pro Push/Pull Cable Set if required
Red Part Numbers = Carb Kit with adapters

**IMPORTANT: Legal in California only for racing vehicles which may never be used upon a highway.**





## Keihin FCR Carburetor Kits for Harley-Davidson®

High performance, bolt-on carburetor kits suitably sized for Harley-Davidson® Big Twin and Sportster models. Keihin FCR carbs feature a smoothbore venturi and accelerator pump for much improved acceleration.

Description	Year	Carb Venturi	Order No.	Description	Year	Carb Venturi	Order No.
Big Twin with K&N Air Filter	90-99	41FCR-H	<b>016-755</b>	XL883 Sportster	90-04	39FCR-H	<b>016-753</b>
Big Twin without Air Filter	90-99	41FCR-H	<b>016-756</b>	XL1200 Sportster	90-04	39FCR-H	<b>016-753</b>



## Keihin FCR Single Carburetors - Sold each. Cable Mounting Brackets are shown on page 112.

Venturi Size/Type	Choke Yes/No	Spigot Order No.	Wire Bracket Order No.	Notes	Carburetor Order No.
28FCR-D	No	<b>15E</b>	<b>021-125</b>	---	<b>016-683</b>
39FCR-D	No	<b>020-490</b>	<b>021-132</b>	---	<b>016-686</b>
39FCR-D	No	<b>020-424</b>	<b>021-132</b>	---	<b>016-687</b>
41FCR-D	No	<b>020-463</b>	<b>021-132</b>	---	<b>016-688</b>
41FCR-D	No	<b>020-454</b>	<b>021-132</b>	---	<b>016-689</b>
28FCR-H	No	<b>888</b>	<b>021-133</b>	---	<b>016-691</b>
33FCR-H	No	<b>16C</b>	<b>021-133</b>	---	<b>016-692</b>
35FCR-H	No	<b>020-429</b>	<b>021-131</b>	---	<b>016-693</b>
37FCR-H	No	<b>020-464</b>	<b>021-129</b>	---	<b>016-694</b>
39FCR-H	No	<b>020-457</b>	<b>021-129</b>	---	<b>016-695</b>
39FCR-H	No	<b>020-468</b>	<b>021-133</b>	---	<b>016-696</b>
39FCR-H	Yes	<b>020-468</b>	<b>021-133</b>	---	<b>016-798</b>
41FCR-H	Yes	<b>020-467</b>	<b>021-133</b>	---	<b>016-799</b>
39FCR-H	Yes	<b>020-450</b>	<b>021-551</b>	Vacuum Port	<b>016-950</b>
39FCR-H	No	<b>020-424</b>	<b>021-134</b>	---	<b>016-951</b>
41FCR-H	Yes	<b>020-467</b>	<b>021-133</b>	---	<b>016-799</b>
41FCR-H	Yes	<b>020-459</b>	<b>021-551</b>	Vacuum Port	<b>016-699</b>
41FCR-H	No	<b>020-467</b>	<b>021-133</b>	---	<b>016-781</b>
41FCR-H	No	<b>020-454</b>	<b>021-134</b>	---	<b>016-960</b>
41FCR-H	No	<b>020-453</b>	<b>021-134</b>	---	<b>016-961</b>
41FCR-H	No	<b>910</b>	<b>021-552</b>	Left Side Bellcrank	<b>016-962</b>
41FCR-H	Yes	<b>020-439</b>	<b>021-133</b>	---	<b>016-963</b>

# KEI HIN FC8 Exploded View

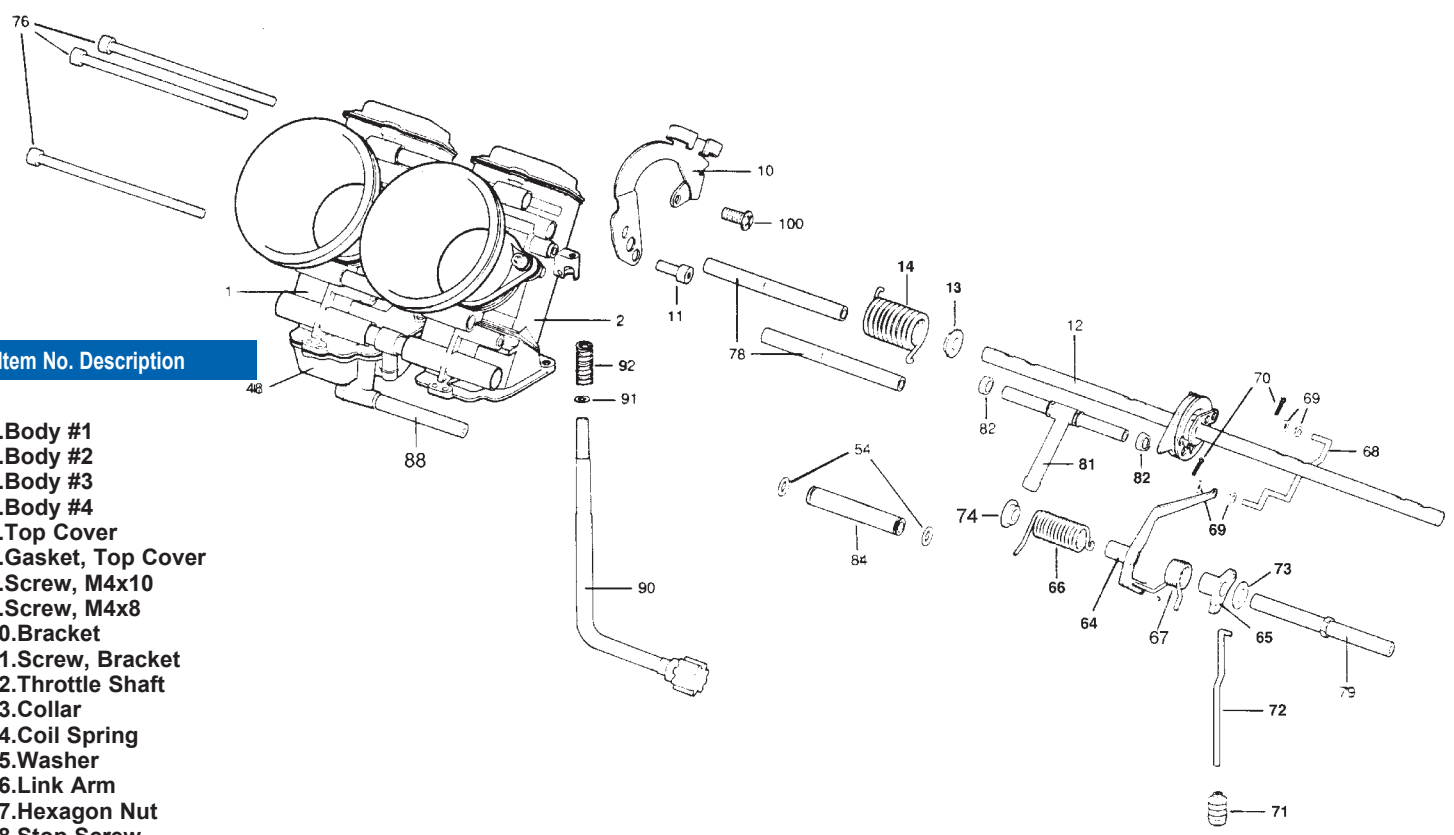

**Item No. Description**

- 1.Body #1
- 2.Body #2
- 3.Body #3
- 4.Body #4
- 5.Top Cover
- 6.Gasket, Top Cover
- 8.Screw, M4x10
- 9.Screw, M4x8
- 10.Bracket
- 11.Screw, Bracket
- 12.Throttle Shaft
- 13.Collar
- 14.Coil Spring
- 15.Washer
- 16.Link Arm
- 17.Hexagon Nut
- 18.Stop Screw
- 19.Throttle Valve
- 20.Roller
- 21.Vacuum Release Plate
- 22.Seal
- 23.Jet Needle
- 24.Clip, Jet Needle
- 25.Needle Jet Screw
- 26.Main Nozzle
- 27.Main Jet
- 28.Slow Jet
- 30.Slow Air Jet
- 32.Pilot Screw
- 33.Coil Spring, Pilot Screw
- 34.O-Ring, Pilot Screw
- 35.Washer, Pilot Screw
- 36.Valve Seat
- 37.O-Ring, Valve Seat
- 38.Screw, Valve Seat
- 39.Float
- 40.Arm Pin
- 41.Screw, Arm Pin
- 42.Float Valve
- 43.Clip, Float Valve
- 45.Packing, Float Bowl
- 47.Cover Acc'p
- 48.Float Bowl #1
- 49.Float Bowl #2
- 50.Float Bowl #4
- 51.Diaphragm
- 52.U-Ring, Acc'p
- 53.Coil Spring, Acc'p
- 54.O-Ring, Acc'p
- 64.Link Lever
- 65.Link Lever
- 66.Coil Spring #1, Link
- 67.Coil Spring #2, Link
- 68.Rod, Link Lever
- 69.Washer, Rod, Link
- 70.Pin, Link Lever
- 71.Rubber Cap
- 72.Rod, Acap

D=Downdraft  
H=Horizontal

**Center Linkage**

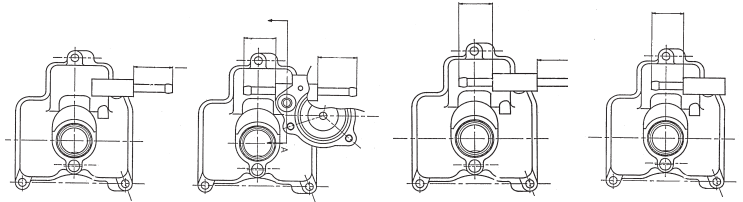

D	<b>021-059</b>	<b>021-061</b>	<b>021-107</b>	<b>021-063</b>
H	<b>021-260</b>	<b>021-259</b>	<b>021-261</b>	<b>021-262</b>

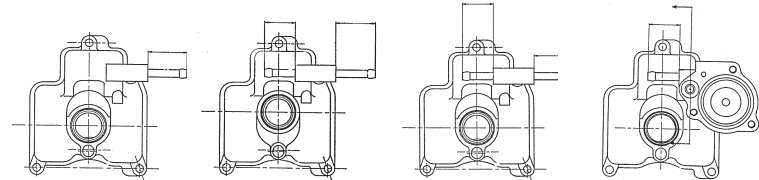

D	<b>021-059</b>	<b>021-107</b>	<b>021-107</b>	<b>021-064</b>
H	<b>021-260</b>	<b>021-261</b>	<b>021-261</b>	<b>021-263</b>

- 73.Washer, Link Lever
- 74.Collar, Link Lever
- 76.Bolt, M5x110
- 77.Spacing Collar #1
- 78.Spacing Collar #2
- 79.Spacing Collar #3
- 80.Rubber Pipe
- 81.Air Vent Joint
- 82.U-Ring, Air Vent
- 84.Fuel Joint (center)

- 85.O-Ring, F. T-Joint
- 88.Rubber Pipe (R.L.)
- 89.Fuel T-Joint
- 90.Step Screw
- 91.Washer, Stop Screw
- 92.Coil Spring, Step Screw
- 100.Screw, Bracket
- 103.Main Air Jet
- 121.Float Bowl #3
- 122.O-Ring, Drain Bolt

- 124.Rubber Pipe (center)
- 125.Mount Adapter
- 126.Velocity Stack
- 127.Rubber Cap, T-Joint
- 128.Clip, Rubber Cap
- 129.Air Cleaner Adapter
- 130.O-Ring, Ram Air Box Adapter

**Right Linkage**

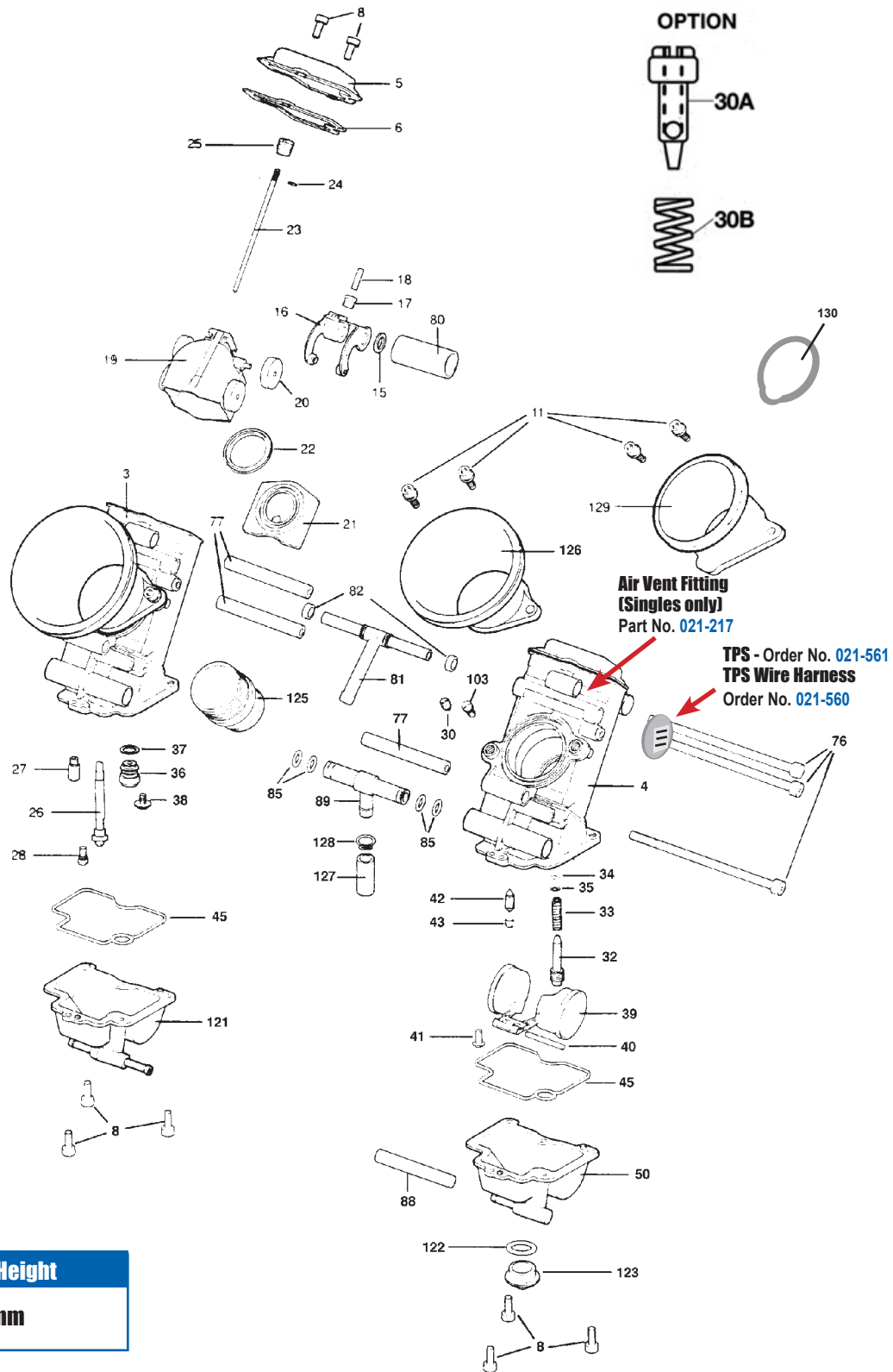

<b>Float Height</b>
<b>9mm</b>

See page 106-107 for Sudco order numbers

## FCR Replacement Parts

**Applications:** Downdraft and Horizontal Single, Dual and Multi.  
 FCR28, FCR33, FCR35, FCR37, FCR39, FCR41.

No.	Description	Application	Keihin No.	Order No.
5.	Top Cover	28-33mm	1030-850-2000	<a href="#">021-002</a>
		35-41mm	1030-855-2000	<a href="#">021-003</a>
6.	Gasket, Top Cover	28-33mm	1031-805-2000	<a href="#">021-005</a>
		35-39mm	1031-806-2000	<a href="#">021-006</a>
		41mm	1031-807-2000	<a href="#">021-007</a>
8.	Screw M4 x 10 x 0.7	All	0136-807-1100	<a href="#">021-008</a>
9.	Screw M4 x 8	All	0136-808-1100	<a href="#">021-010</a>
10. Cable Mounting Brackets (For photo see page 112)				
	CBR600F	32-33mm	1190-979-2200	<a href="#">021-127</a>
	CBR600F2/F3	32-33mm	1190-979-2300	<a href="#">021-126</a>
	FZR400/600, YZF600	32-33mm	1190-979-2102	<a href="#">021-125</a>
	ZX-6, ZX-10, ZX-11	35-41mm	1190-981-2100	<a href="#">021-129</a>
	GSX-R Air Cooled (all)	35-41mm	1190-981-2100	<a href="#">021-129</a>
	Triumph, Kaw Zephyr	35-41mm	1190-981-2100	<a href="#">021-129</a>
	BMW, Suz LT-Z	35-41mm	1190-981-2100	<a href="#">021-129</a>
	CBR600F3	35-41mm	1190-981-2300	<a href="#">021-131</a>
	CBR900RR, CB1000	35-41mm	1190-981-2200	<a href="#">021-131</a>
	YZF600R, YZF1000R	35-41mm	1190-981-2200	<a href="#">021-131</a>
	FZR750R, FZR1000	35-41mm	1190-981-2200	<a href="#">021-131</a>
	Ducati Single/Dual	35-41mm	1190-981-2300	<a href="#">021-132</a>
	SV650 (front), KTM <sup>(950 twin)</sup>	35-41mm	1190-981-2300	<a href="#">021-132</a>
	SV650 (rear)	35-41mm	1190-A33-2200	<a href="#">021-134</a>
	Single Carb 15° degree			
	KTM <sup>(single)</sup> , XR250, SR500	41mm	1190-A33-2100	<a href="#">021-133</a>
	Single Carb 30° degree			
	XR600R, TRX400EX	35-41mm	1190-A33-2200	<a href="#">021-134</a>
	Yam YFM660 Raptor	39-41mm	1190-A33-2200	<a href="#">021-134</a>
	BMW (Dual)	37-41mm	1190-A33-2200	<a href="#">021-134</a>
	H-D Evo CV Carb	41mm	1190-B12-2100	<a href="#">021-551</a>
	(for stock cable)			
	Single Carb 30° deg.	35-41mm	1190-A33-2300	<a href="#">021-549</a>
	GSX-R750 (96-97)	35-41mm	1190-A77-2000	<a href="#">021-550</a>
	GSX-R Liquid Cooled	35-41mm	1190-988-2200	<a href="#">021-249</a>
	Vulcan 1500	35-41mm	1190-988-2200	<a href="#">021-249</a>
	Moto-Guzzi	35-41mm	1190-988-2200	<a href="#">021-249</a>
	ZX-7 (91-96), ZX-9R	35-41mm	1190-988-2100	<a href="#">021-122</a>
	YZF-R6	35-41mm	1190-988-2100	<a href="#">021-122</a>
	XR650 Left Bellcrank	35-41mm	1190-B84-2100	<a href="#">021-552</a>
11.	Screw, Bracket	All	0136-803-1100	<a href="#">021-012</a>
12. Throttle Shaft				
	Pitch 86 - 92 - 86		5025-956-2100	<a href="#">021-139</a>
	Pitch 75 - 86 - 75		5025-955-2200	<a href="#">021-141</a>
	Pitch 75 - 75 - 75		5025-977-2200	<a href="#">021-142</a>
	Pitch 71 - 83 - 71		5025-953-2100	<a href="#">021-143</a>
	Pitch 101		5025-984-2100	<a href="#">021-144</a>
13.	Collar	All	1118-958-7000	<a href="#">021-014</a>
14. Coil Spring				
	standard/multi	All	1305-932-2001	<a href="#">021-016</a>
	single, light multi	All	1305-942-2000	<a href="#">021-253</a>
15.	Washer	All	0301-092-7000	<a href="#">021-018</a>
16. Link Arm				
		28-33mm	1061-815-2100	<a href="#">021-020</a>
		35-41mm	1061-816-2100	<a href="#">021-021</a>
17.	Hexagon Nut	All	0208-811-1100	<a href="#">021-023</a>
18.	Stop Screw	All	1034-836-2000	<a href="#">021-025</a>
19. Throttle Valve				
		28-33mm	N501-18C02	<a href="#">021-300</a>
		35-41mm	N501-20C00	<a href="#">021-325</a>
20.	Roller	All	1119-803-7002	<a href="#">021-027</a>
21. Vacuum Release				
		28-33mm	1609-801-2101	<a href="#">021-029</a>
	Plate	35-41mm	1609-802-2101	<a href="#">021-030</a>
22. Seal				
		28-33mm	1099-816-6001	<a href="#">021-032</a>
		35-41mm	1099-817-6001	<a href="#">021-033</a>

No.	Description	Application	Keihin No.	Order No.
23.	Jet Needle	28-33mm	N427-90-XXX	<a href="#">Pg.118</a>
		35-41mm	N427-0C-XXX	<a href="#">Pg.118</a>
24.	Clip for Jet Needle	All	0403-802-1000	<a href="#">018-616</a>
25.	Needle Set Screw	All	1421-801-2000	<a href="#">021-034</a>
26. Main Nozzle				
		All Downdraft	1154-835-2100	<a href="#">021-037</a>
		All Horizontal	1154-838-2000	<a href="#">021-036</a>
27.	Main Jet	All	99101-357-XXX	<a href="#">Pg.150</a>
28.	Slow Jet	All	N424-25B-XXX	<a href="#">Pg.148</a>
30. Slow Air Jet				
		All	99101-124-XXX	<a href="#">Pg.149</a>
			99101-ZF5-XXX	(old part no.)
30A.	Air Screw	All	1014-817-2000	<a href="#">021-230</a>
30B.	Coil Spring	All	16052-KM4-0040	<a href="#">021-235</a>
32. Pilot Screw				
		6 ° taper, All	N446-05A00	<a href="#">021-039</a>
		9 ° taper, All	N446-05C00	<a href="#">021-038</a>
33.	Spring, Pilot Screw	All	1290-812-2001	<a href="#">021-041</a>
34. O-Ring, Pilot Screw				
		All	16075-KG8-9010-M1	<a href="#">021-043</a>
35.	Washer, Pilot Screw	All	0301-803-2000	<a href="#">021-045</a>
36. Valve Seat				
		Size	N361-03-XXX	
	Use with Float Valve		<a href="#">018-676</a>	
	All Downdraft	1.00	N361-03-1.00	<a href="#">021-218</a>
	All Downdraft	1.20	N361-03-1.20	<a href="#">021-219</a>
	All Downdraft	1.40	N361-03-1.40	<a href="#">021-220</a>
	All Downdraft	1.60	N361-03-1.60	<a href="#">021-221</a>
	All Downdraft	1.80	N361-03-1.80	<a href="#">021-222</a>
	All Downdraft	2.00 (Std)	N361-03-2.00	<a href="#">021-223</a>
	All Downdraft	2.20	N361-03-2.20	<a href="#">021-224</a>
	All Downdraft	2.40	N361-03-2.40	<a href="#">021-225</a>
	All Downdraft	2.60	N361-03-2.60	<a href="#">021-226</a>
	Valve Seat	Size	N361-043-XXX	
	Use with Float Valve		<a href="#">018-504</a>	
	All Horizontal	3.20 (Std)	N361-043-3.20	<a href="#">021-240</a>
	All Horizontal	3.40	N361-043-3.40	<a href="#">021-241</a>
	All Horizontal	3.60	N361-043-3.60	<a href="#">021-242</a>
	All Horizontal Singles	3.80 (Std)	N361-043-3.80	<a href="#">021-243</a>
	All Horizontal	4.00	N361-043-4.00	<a href="#">021-244</a>
37. O-Ring, Valve Seat				
		All	16958-397-7710-M1	<a href="#">021-047</a>
38. Screw, Valve Seat				
		Downdraft	0118-804-1100	<a href="#">021-049</a>
		Horizontal	0118-806-1100	<a href="#">021-250</a>
39.	Float	All	1052-837-2200	<a href="#">021-051</a>
40.	Arm Pin	All	W9525-25250	<a href="#">018-670</a>
41. Screw, Arm Pin				
		All	93500-04008-1H	<a href="#">021-053</a>
42. Float Valve (Needle Valve)				
	Downdraft (1.0 - 2.6)	All	16155-ZG8-L100	<a href="#">018-676</a>
	Horizontal (3.2 - 4.0)	All	1062-814-2100	<a href="#">018-504</a>
43.	Clip, Float Valve	All	0405-019-1000	<a href="#">018-674</a>
45.	O-Ring, Float Bowl	All	1202-846-6000	<a href="#">021-055</a>
47.	Cover, Accel. Pump	All	1230-826-2001	<a href="#">021-057</a>
48.	Float Bowl #1	Horizontal	1050-881-2100	<a href="#">021-260</a>
49. Float Bowl #1				
		Downdraft	1050-864-2100	<a href="#">021-059</a>
	Float Bowl #2	Downdraft	1050-865-2100	<a href="#">021-061</a>
		w/center pull		
	Float Bowl #2	Horizontal	1050-880-2100	<a href="#">021-259</a>
		w/center pull		
	Float Bowl (single)	Downdraft	1050-868-2100	<a href="#">021-258</a>
	Float Bowl (single)	Horizontal	1050-886-2100	<a href="#">021-264</a>
50. Float Bowl #4				
		Downdraft	1050-866-2100	<a href="#">021-063</a>
		w/center pull		
	Float Bowl #4	Downdraft	1050-862-2100	<a href="#">021-064</a>
		w/right pull		
	Float Bowl #4	Horizontal	1050-885-2100	<a href="#">021-263</a>
		w/right pull		
	Float Bowl #4	Horizontal	1050-883-2100	<a href="#">021-262</a>
		w/center pull		



No.	Description	Application	Keihin No.	Order No.	No.	Description	Application	Keihin No.	Order No.
51.	Diaphragm	All	1201-858-2400	<b>021-065</b>	81.	Air Vent Joint	4-cylinder	1077-826-7000	<b>021-187</b>
52.	U-Ring, Accel. Pump	All	W9353-36000	<b>021-067</b>		(Breather)	Ducati (Dual)	1077-806-7001	<b>021-188</b>
53.	Spring, Accel. Pump	All	1300-142-2000	<b>021-069</b>	82.	U-Ring, Air Vent	All	W9353-65000	<b>021-097</b>
54.	O-Ring, Accel. Pump	All	16178-548-0040	<b>021-071</b>	84.	Fuel Joint (center)	CBR600, CB-1	1075-834-2000	<b>021-191</b>
64.	Link Lever	28-33mm	1100-868-2100	<b>021-073</b>			FZR400/600	1075-834-2000	<b>021-191</b>
		35-41mm	1100-870-2100	<b>021-074</b>			FZR750/1000	1075-834-2000	<b>021-191</b>
65.	Link Lever	Downdraft	1100-867-7001	<b>021-076</b>			ZX-7	1075-836-2000	<b>021-193</b>
		Horizontal	1100-872-7000	<b>021-252</b>			ZX-10, ZX-11	1075-836-2000	<b>021-193</b>
66.	Coil Spring #1	All	1305-933-2000	<b>021-078</b>	85.	O-Ring, Fuel T-Joint	All(Ex Ducati)	W9351-13057	<b>018-755</b>
67.	Coil Spring #2					Ducati Duals Only	Duals	16178-548-0040	<b>021-071</b>
	Downdraft	28-33mm	1305-934-2000	<b>021-080</b>	88.	Rubber Pipe			
	Downdraft	35-41mm	1305-939-2000	<b>021-081</b>		45mm (R & L side.)	CBR600, CB-1	W1785-032-9900	<b>021-197</b>
	Horizontal	All	1305-952-2000	<b>021-254</b>		45mm (R & L side.)	FZR400/600	W1785-032-9900	<b>021-197</b>
68.	Rod, Link Lever	All	1458-825-2000	<b>021-083</b>		60mm (R,L & C)	FZR750/1000	0804-437-0001	<b>021-201</b>
	Rod, Link Lever	GSX-R	1458-827-2000	<b>021-256</b>		60mm (R,L & C)	GSX-R750 93-95		<b>021-201</b>
		(liquid cooled)				70mm	ZX-7	0804-986-0000	<b>021-209</b>
	Flat, Link Arm		1061-818-2100	<b>021-022</b>		70mm	ZX-10, ZX-11	0804-986-0000	<b>021-209</b>
69.	Washer, Rod Link	All	0301-136-7000	<b>021-085</b>		40mm	(*Option)	0804-444-0000	<b>021-202</b>
70.	Pin, Link Lever	All	W9251-12081	<b>021-087</b>		50mm	(*Option)	0804-991-0000	<b>021-203</b>
71.	Rubber Cap	All	1028-825-2001	<b>021-089</b>		80mm	(*Option)	0804-987-0000	<b>021-210</b>
72.	Rod	Downdraft	1458-826-2000	<b>021-091</b>	89.	Fuel T-Joint			
		Horizontal	1458-829-2000	<b>021-255</b>			CBR600, CB-1	1077-804-7000	<b>018-751</b>
73.	Washer, Link Lever	All	0301-114-1100	<b>021-093</b>			FZR400/600	1077-804-7000	<b>018-751</b>
74.	Collar, Link Lever	All	W1704-241-9900	<b>021-095</b>			ZX-6	1077-804-7000	<b>018-751</b>
76.	Bolt M5						ZX-10, ZX-11	1077-804-7000	<b>018-751</b>
	M5 x 95mm	CBR600	0136-801-1100	<b>021-145</b>			FZR750/1000	1077-803-7000	<b>018-753</b>
	M5 x 95mm	FZR400/600	0136-801-1100	<b>021-145</b>			GSX-R	1077-803-7000	<b>018-753</b>
	M5 x 100mm	ZX-6, ZX-7	0136-811-1100	<b>021-147</b>			(liquid cooled)		
	M5 x 100mm	ZX-10, ZX-11	0136-811-1100	<b>021-147</b>			Downdraft	1074-848-2100	<b>021-251</b>
	M5 x 110mm	FZR750/1000	0136-812-1100	<b>021-149</b>			(single)		
	M5 x 90mm	(*Option)	0136-809-1100	<b>021-146</b>			Ducati (Dual)	1077-844-2000	<b>021-190</b>
77.	Spacing Collar #1				90.	Idle Speed Screw	All	1034-837-2100	<b>021-099</b>
	56mm	CB-1, CBR600	N704-01056	<b>021-153</b>			13.25"	1034-837-2501	<b>021-531</b>
	56mm	FZR400/600	N704-01056	<b>021-153</b>	91.	Washer	All	0301-078-1200	<b>021-101</b>
	60mm	ZX-6,	N704-01060	<b>021-155</b>	92.	Spring	All	1300-112-2000	<b>021-103</b>
	60mm	ZX-10, ZX-11	N704-01060	<b>021-155</b>	100.	Screw, Bracket	All	0136-804-1100	<b>021-105</b>
	71mm	FZR750/1000	N704-01071	<b>021-157</b>	103.	Main Air Jet	35-41mm	99101-393-XXX	<b>Pg.150</b>
	50mm	(*Option)	N704-01050	<b>021-151</b>	121.	Float Bowl #2	Downdraft	1050-863-2100	<b>021-107</b>
	53mm	(*Option)	N704-01053	<b>021-152</b>			with right pull		
	68mm	(*Option)	N704-01068	<b>021-156</b>		Float Bowl #3	Downdraft	1050-863-2100	<b>021-107</b>
78.	Spacing Collar #2						with center pull		
	71mm	ZX-7,	N704-02071	<b>021-161</b>		Float Bowl #2	Horizontal	1050-882-2100	<b>021-261</b>
	71mm	ZX-10, ZX-11	N704-02071	<b>021-161</b>			with right pull		
	77mm	CB-1,	N704-02077	<b>021-163</b>		Float Bowl #3	Horizontal	1050-882-2100	<b>021-261</b>
	77mm	FZR750/1000	N704-02077	<b>021-163</b>			with center pull		
	81mm	ZX-6, CBR600	N704-02081	<b>021-167</b>	122.	O-Ring, Drain Bolt	All	16075-935-0060	<b>021-109</b>
	81mm	FZR400/600	N704-02081	<b>021-167</b>	123.	Drain Bolt	All	1018-804-2000	<b>021-111</b>
	50mm	(*Option)	N704-02050	<b>021-158</b>	124.	Rubber Pipe			
	53mm	(*Option)	N704-02053	<b>021-159</b>		60mm length	ZX-6, ZX-7	0804-437-0001	<b>021-201</b>
	68mm	(*Option)	N704-02068	<b>021-160</b>		60mm length	ZX-10, ZX-11	0804-437-0001	<b>021-201</b>
	89mm	(*Option)	N704-02089	<b>021-168</b>		70mm length	CBR600, CB-1	0804-986-0000	<b>021-209</b>
79.	Spacing Collar #3					70mm length	FZR750/1000	0804-986-0000	<b>021-209</b>
	71mm	ZX-10, ZX-11	N704-03071	<b>021-171</b>		80mm length	(*Option)	0804-987-0000	<b>021-210</b>
	77mm	CB-1	N704-03077	<b>021-173</b>	125.	Mounting Adapters	(Spigots)		<b>Pg.110-111</b>
	77mm	FZR750/1000	N704-03077	<b>021-173</b>	126.	Velocity Stacks - Sold each			
	81mm	CBR600, ZX-6	N704-03081	<b>021-175</b>		Blue, 50mm long	28-33mm	1130-806-7002	<b>021-113</b>
	81mm	FZR400/600	N704-03081	<b>021-175</b>		Blue, 50mm long	35-41mm	1130-807-7000	<b>021-114</b>
	56mm	(*Option)	N704-03056	<b>021-169</b>		Red, 30mm long	35-41mm	1130-808-7000	<b>021-115</b>
	60mm	(*Option)	N704-03060	<b>021-170</b>	127.	Rubber Cap, T-Joint	All	1028-808-7000	<b>018-759</b>
	65mm	(*Option)	N704-03065	<b>021-172</b>	128.	Clip, Rubber Cap	All	W9535-55000	<b>018-761</b>
	68mm	(*Option)	N704-03068	<b>021-174</b>	129.	Air Filter Adapters			<b>Pg.120-121</b>
	89mm	(*Option)	N704-03089	<b>021-176</b>	130.	O-Ring, Air Cleaner	35-41mm		<b>021-439</b>
80.	Rubber Pipe					Adapter			
	34mm	CBR600	0804-985-0000	<b>021-179</b>					
	34mm	FZR400/600	0804-985-0000	<b>021-179</b>					
	34mm	CB-1, ZX-7	0804-985-0000	<b>021-179</b>					
	34mm	ZX-10, ZX-11	0804-985-0000	<b>021-179</b>					
	41mm	ZX-6	0804-990-0000	<b>021-181</b>					
	46mm	FZR750/1000	0804-992-0000	<b>021-183</b>					
	31mm	(*Option)	0804-988-0000	<b>021-180</b>					

See page 109 for FCR Carburetor Rebuild Kits. See Pages 110-113 for additional FCR parts and accessories

VINTAGE  
 INTAKE  
 ENGINE  
 SUSPENSION  
 CONTROL  
 ELECTRICAL  
 CHEMICAL  
 TOOLS  
 WATERCRAFT

# KEIHIN FCR Single Exploded View

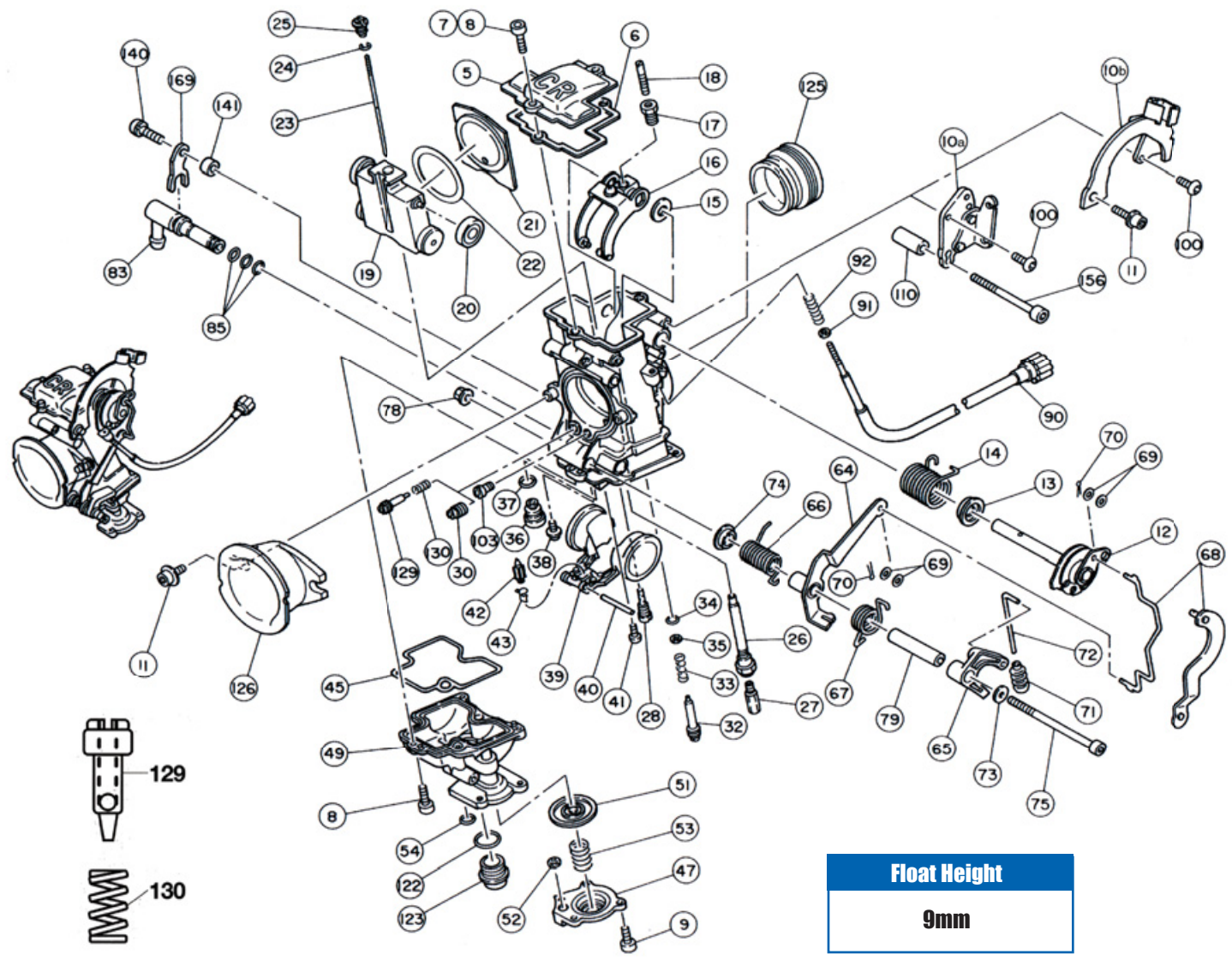

**Float Height**  
**9mm**

## FCR Single Replacement Parts

**Applications:** Downdraft and Horizontal Single Carburetors.  
FCR28, FCR32, FCR33, FCR35, FCR37, FCR39, FCR41.

No.	Description	Application	Keihin No.	Order No.
5.	Top Cover	28-33mm	1030-850-2000	<b>021-002</b>
		35-41mm	1030-855-2000	<b>021-003</b>
		35-39mm	1031-805-2000	<b>021-005</b>
		41mm	1031-806-2000	<b>021-006</b>
6.	Gasket, Top Cover	All	1031-807-2000	<b>021-007</b>
		All	0136-806-1100	<b>021-700</b>
		All	0136-807-1100	<b>021-008</b>
9.	Screw M4 x 8	All	0136-808-1100	<b>021-010</b>
10.	Cable Mount Brackets	<b>See Page 112 for photos and apps.</b>		
10A.	Cable Mount Bracket	All	1190-A33-2300	<b>021-549</b>
10B.	Cable Mount Bracket	All	1190-981-2100	<b>021-129</b>
11.	Screw, Bracket	All	0136-803-1100	<b>021-012</b>
12.	Throttle Shaft	All	5025-960-2101	<b>021-701</b>
13.	Collar	All	1118-958-7000	<b>021-014</b>
14.	Coil Spring	All	1305-942-2000	<b>021-253</b>
15.	Washer	All	0301-092-7000	<b>021-018</b>
16.	Link Arm	28-33mm	1061-815-2100	<b>021-020</b>
		35-41mm	1061-816-2100	<b>021-021</b>
17.	Hexagon Nut	All	0208-811-1100	<b>021-023</b>

No.	Description	Application	Keihin No.	Order No.
18.	Stop Screw	All	1034-836-2000	<b>021-025</b>
19.	Throttle Valve	28-33mm	N501-18C02	<b>021-300</b>
		35-41mm	N501-20C00	<b>021-325</b>
20.	Roller	All	1119-803-7002	<b>021-027</b>
		28-33mm	1609-801-2101	<b>021-029</b>
21.	Vacuum Release Plate	35-41mm	1609-802-2101	<b>021-030</b>
		28-33mm	1099-816-6001	<b>021-032</b>
22.	Seal	35-41mm	1099-817-6001	<b>021-033</b>
		28-33mm	N427-90-xxx	<b>Pg.118</b>
23.	Jet Needle	35-41mm	N427-OC-xxx	<b>Pg.118</b>
		All	0403-802-1000	<b>018-616</b>
24.	Clip for Jet Needle	All	1421-801-2000	<b>021-034</b>
25.	Needle Set Screw	All	1154-835-2100	<b>021-037</b>
26.	Main Nozzle	Downdraft	1154-838-8000	<b>021-036</b>
		Horizontal	99101-357-xxx	<b>Pg.150</b>
27.	Main Jet	All	N424-25B-xxx	<b>Pg.148</b>
28.	Slow Jet	All	99101-124-xxx	<b>Pg.149</b>
30.	Slow Air Jet	All	99101-2F5-xxx (old part no.)	

**Part no. #30, Slow Air Jet can be replaced with Slow Air Screw, see Part no. #129 and #130 in drawing.**

**IMPORTANT:** Legal in California only for racing vehicles which may never be used upon a highway.

No.	Description	Application	Keihin No.	Order No.	No.	Description	Application	Keihin No.	Order No.
32.	Pilot Screw	6 ° taper, All	N446-05A00	<b>021-039</b>	85.	O-Ring, Fuel L-Joint	All	W9351-13057	<b>018-755</b>
	(*Option)	9 ° taper,	N446-05C00	<b>021-038</b>	90.	Idle Speed Screw	All	1034-837-2100	<b>021-099</b>
33.	Spring, Pilot Screw	All	1290-812-2001	<b>021-041</b>	91.	Washer	All	0301-078-1200	<b>021-101</b>
34.	O-Ring, Pilot Screw	All	16075-KG8-9010	<b>021-043</b>	92.	Spring	All	1300-112-2000	<b>021-103</b>
		M1			100.	Screw, Bracket	All	0136-804-1100	<b>021-105</b>
35.	Washer, Pilot Screw	All	0301-803-2000	<b>021-045</b>	103.	Main Air Jet	35-41mm	99101-393-xxx	<b>Pg.150</b>
36.	Valve Seat	Size			110.	Collar		N704-05017	<b>021-563</b>
	All Downdraft FCR - Use with Float Valve		<b>018-676</b>		122.	O-Ring, Drain Bolt	All	16075-935-0060	<b>021-109</b>
	All Downdraft	1.00	N361-03-xxx	<b>021-218</b>	123.	Drain Bolt	All	1018-804-2000	<b>021-111</b>
	All Downdraft	1.20	N361-03-xxx	<b>021-219</b>	125.	Mounting Adapters (Spigots)			<b>Pg.110-111</b>
	All Downdraft	1.40	N361-03-xxx	<b>021-220</b>	126.	Velocity Stacks -	Sold each		
	All Downdraft	1.60	N361-03-xxx	<b>021-221</b>		Blue, 50mm long	28-33mm	1130-806-7002	<b>021-113</b>
	All Downdraft	1.80	N361-03-xxx	<b>021-222</b>		Blue, 50mm long	35-41mm	1130-807-7000	<b>021-114</b>
	All Downdraft	2.00 (Std)	N361-03-xxx	<b>021-223</b>		Red, 30mm long	35-41mm	1130-808-7000	<b>021-115</b>
	All Downdraft	2.20	N361-03-xxx	<b>021-224</b>	129.	Slow Air Screw	All	1014-817-2000	<b>021-230</b>
	All Downdraft	2.40	N361-03-xxx	<b>021-225</b>	130.	Spring	All	16052-KM4-0040	<b>021-235</b>
	All Downdraft	2.60	N361-03-xxx	<b>021-226</b>	140.	Bolt		N114-06161	<b>021-705</b>
	Valve Seat	Size			141.	Collar		1118-984-2000	<b>021-706</b>
	All Horizontal FCR - Use with Float Valve		<b>018-504</b>		156.	Bolt		0136-812-1100	<b>021-150</b>
	All Horizontal	3.20 (Std)	N361-04-xxx	<b>021-240</b>	169.	Bracket		1190-A11-2000	<b>021-850</b>
	All Horizontal	3.40	N361-04-xxx	<b>021-241</b>					
	All Horizontal	3.60	N361-04-xxx	<b>021-242</b>					
	All Horizontal Singles	3.80 (Std)	N361-04-xxx	<b>021-243</b>					
	All Horizontal	4.00	N361-04-xxx	<b>021-244</b>					
37.	O-Ring, Valve Seat	All	16958-397-7710	<b>021-047</b>					
		M1							
38.	Screw, Valve Seat	Downdraft	0118-804-1100	<b>021-049</b>					
		Horizontal	0118-806-1100	<b>021-250</b>					
39.	Float	All	1052-837-2200	<b>021-051</b>					
40.	Arm Pin	All	W9525-25250	<b>018-670</b>					
41.	Screw, Arm Pin	All	93500-04008-1H	<b>021-053</b>					
42.	Float Valve (Needle Valve)								
	Downdraft (1.0 - 2.6)	All	16155-ZG8-L100	<b>018-676</b>					
	Horizontal (3.2 - 4.0)	All	1062-814-2100	<b>018-504</b>					
43.	Clip, Float Valve	All	0405-019-1000	<b>018-674</b>					
45.	O-Ring, Float Bowl	All	1202-846-6000	<b>021-055</b>					
47.	Cover, Accel. Pump	All	1230-826-2002	<b>021-057</b>					
49.	Float Bowl	Downdraft	1050-868-2100	<b>021-258</b>					
	Float Bowl	Horizontal	1050-886-2100	<b>021-264</b>					
51.	Diaphragm	All	1201-858-2400	<b>021-065</b>					
52.	U-Ring, Accel. Pump	All	W9353-3600	<b>021-067</b>					
53.	Spring, Accel. Pump	All	1300-142-2000	<b>021-069</b>					
54.	O-Ring, Accel. Pump	All	16178-548-0040	<b>021-071</b>					
64.	Link Lever	28-33mm	1100-868-2100	<b>021-073</b>					
		35-41mm	1100-870-2100	<b>021-074</b>					
65.	Link Lever	Downdraft	1100-867-7001	<b>021-076</b>					
		Horizontal	1100-872-7000	<b>021-252</b>					
66.	Coil Spring #1	All	1305-933-2000	<b>021-078</b>					
67.	Coil Spring #2								
	Downdraft	28-33mm	1305-934-2000	<b>021-080</b>					
	Downdraft	35-41mm	1305-939-2000	<b>021-081</b>					
	Horizontal	All	1305-952-2000	<b>021-254</b>					
68.	Rod, Link Lever	All	1458-825-2000	<b>021-083</b>					
	Rod, Link Lever	GSX-R	1458-827-2000	<b>021-256</b>					
		liquid cooled							
	Flat, Link Arm		1061-818-2100	<b>021-022</b>					
69.	Washer, Rod Link	All	0301-136-7000	<b>021-085</b>					
70.	Pin, Link Lever	All	W9251-12081	<b>021-087</b>					
71.	Rubber Cap	All	1028-825-2001	<b>021-089</b>					
72.	Rod	Downdraft	1458-826-2000	<b>021-091</b>					
		Horizontal	1458-829-2000	<b>021-255</b>					
73.	Washer, Link Lever	All	W1795-097-9900	<b>021-856</b>					
74.	Collar, Link Lever	All	W1704-241-9900	<b>021-095</b>					
75.	Bolt	All	0136-818-1100	<b>021-702</b>					
78.	Nut	All	0208-810-1100	<b>021-703</b>					
79.	Collar	All	1118-959-2000	<b>021-704</b>					
83.	Fuel L-Joint	Downdraft	1074-848-2100	<b>021-251</b>					
	Fuel L-Joint	Horizontal	1074-848-2300	<b>021-854</b>					

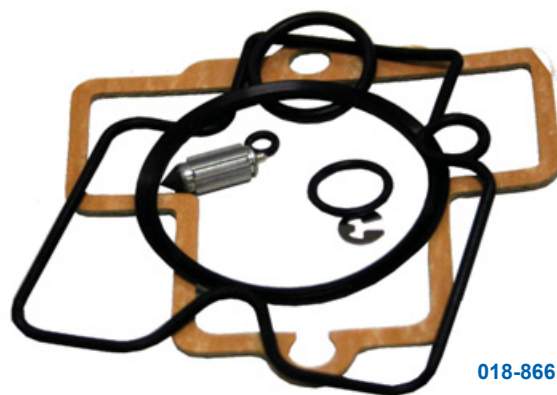

018-866

## Sudco FCR Carburetor Rebuild Kits

Each kit contains genuine KEIHIN parts to rebuild one Keihin Flat-CR Smoothbore carburetor body. Order per kit needed, one or more depending on number of carbs on bike. **Made in Japan.**

H - Horizontal Carburetor

D - Downdraft Carburetor

### Keihin Flat CR Downdraft

Application	Order No.
28-33 FCR-D	<b>018-865</b>
35-39 FCR-D	<b>018-866</b>
41 FCR-D	<b>018-867</b>

### Keihin Flat CR Horizontal

28-33 FCR-H	<b>018-865</b>
35-39 FCR-H	<b>018-870</b>
41 FCR-H	<b>018-871</b>

## Sudco FCR Cable Choke Assembly

For FCR single carburetor. Sold as an assembly.

Order No. **018-977**

Contains the following parts:

Qt	Description
1	Starter Valve
1	Coil Spring
1	Cap
1	Rubber



# KEIHIN FCR Mounting Adapters (Spigots)

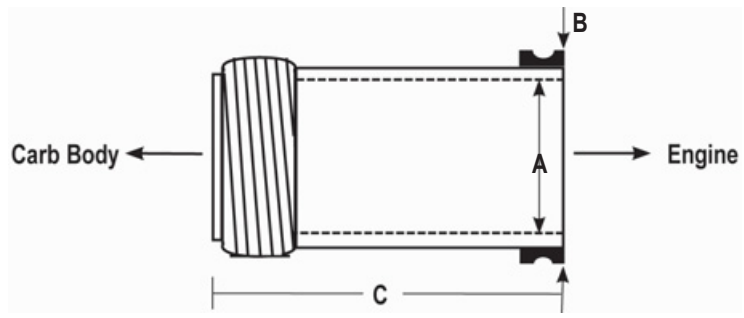

For CR Special Spigots, see page 126-127

## Keihin FCR Mounting Adapters (Spigots) Sold each.

### FCR28

Application	Year	I.D. Mark	Spigot O.D. "B"	Port I.D. "A"	Overall Length "C"	Order No.
FCR28-H	STD	888	29mm	24mm	27mm	_____
FCR28-D	STD	15E	33mm	27mm	25mm	_____

### FCR35

Honda XR250		37A	40mm	35.65mm	26mm	020-416
Norton Commando		37A	40mm	35.65mm	26mm	020-416
Suzuki DR350	90-99	37C	42mm	35.65mm	23mm	020-429
Honda CBR600F2	91-94	37B	41mm	35mm	34mm	020-428
Honda CBR600F3	95-98	894	44mm	36.40mm	41.5mm	020-462
Yamaha SRX600	1986	877	38mm	33mm	24mm	020-466
Kawasaki ZX6		19A	42mm	36.80mm	20mm	020-420
Yamaha YFM660 Raptor	01-05		40mm	35mm	20mm	020-419
Kawasaki KZ1000		39A	42mm	36mm	40mm	020-488
Yamaha YZF-R6	99-02	19F	44mm	37.60mm	31mm	_____

### FCR37

Kawasaki KZ/GPz		34A	42mm	36mm	40mm	020-487
BMW R100		873	42mm	35.50mm	30mm	020-464

### FCR39

BMW R100		872	52mm	40.01mm	30mm	020-457
Ducati (dual carb)		21D	46mm	38mm	22mm	020-422
Ducati (single carb)		27A	44.50mm	39.65mm	37mm	020-424
Honda TRX400EX		27A	44.50mm	39.65mm	37mm	020-424
Kawasaki ZX-7	91-95	862	48mm	40.30mm	18.8mm	020-460
Kawasaki ZX-10	88-90	24A	42mm	36.80mm	26mm	020-440
Suzuki DR-Z400	00-07	24A	42mm	36.80mm	26mm	020-440
Suzuki LT-Z400	03-07	24A	42mm	36.80mm	26mm	020-440
Kawasaki ZX-11C	90-93	25A	47mm	40.80mm	26mm	020-441
Kawasaki ZX-9R	94-97	25A	47mm	40.80mm	26mm	020-441
Kawasaki ZX-11D	93-01	25B	47mm	40.80mm	46mm	020-423
Suzuki GSX-R750 Air Cooled	88-92	21C	46mm	39.65mm	31mm	020-444
Suzuki GSX-R750 Water Cooled	93-95	BDE-39				020-451
Suzuki GSX-R750	96-97	21G	46mm	39.50mm	22mm	020-446
Suzuki SV650	99-02	21C	46mm	39.65mm	31mm	020-444
Suzuki GSX-R1100	91-98	868	41.50mm	37.50mm	31mm	020-455
Suzuki RF900R	94-97	26C	42mm	36mm	36mm	_____
Yamaha YZF750R	94-98	21A	46mm	38mm	40mm	020-421
Yamaha FZR1000R	89-95	21B	46mm	37.65mm	40mm	020-445
Yamaha FZR1000R	87-88	26A	44mm	37.65mm	40mm	020-442
Yamaha FZR750R (OW01)		875	46mm	42mm	40mm	020-450
Harley-Davidson® Sportster		875	46mm	42mm	40mm	020-450
Yamaha SRX600	all	876	38mm	33mm	24mm	020-458
Yamaha SR500	78-81	880	41.70mm	37.50mm	28mm	020-468
Honda CBR900RR		21E	47mm	39mm	41.50mm	020-485
Triumph Speed Triple		26D	42mm	36mm	31mm	_____
Triumph Bonneville/Thruxton/		24A	42mm	36.80mm	26mm	020-440
BMW F650		905	41.7mm	37.50mm	28mm	_____
Yamaha XJR1200		24C	42mm	36.80mm	36mm	_____
Kawasaki Zephyr/ZRX1100		35A	42mm	35.95mm	40mm	020-492
Kawasaki KZ/GPz		35A	42mm	35.95mm	40mm	020-492
Kawasaki Zephyr/ZRX1200		24A	42mm	36.80mm	26mm	020-440

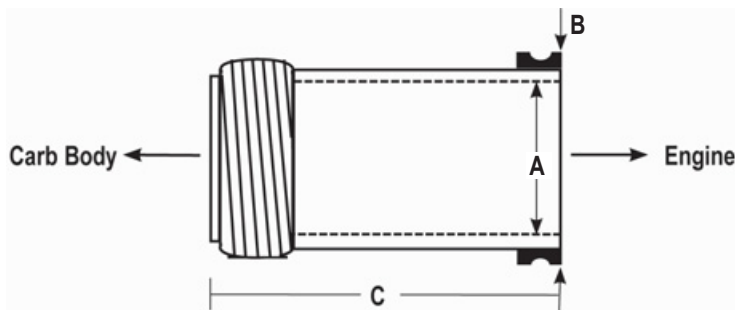

## Keihin FCR Mounting Adapters (Spigots) Sold each.

### FCR41

Application	Year	I.D. Mark	Spigot O.D. "B"	Port I.D. "A"	Overall Length "C"	Order No.
Ducati (dual carb)		33E	46mm	38mm	22mm	<a href="#">020-493</a>
Ducati (single carb)		866	44.50mm	39.65mm	37mm	<a href="#">020-454</a>
Honda TRX400EX		866	44.50mm	39.65mm	37mm	<a href="#">020-454</a>
Harley-Davidson® Big Twin		883	45mm	40.50mm	20mm	<a href="#">020-459</a>
Honda NT650 Hawk GT	88-91	865	44mm	39mm	31mm	<a href="#">020-463</a>
Kawasaki ZX-7	91-95	864	48mm	41.65mm	18.80mm	<a href="#">020-453</a>
Honda XR600R		864	48mm	41.65mm	18.80mm	<a href="#">020-453</a>
Honda XR650R		910	49mm	43mm	27mm	---
Kawasaki ZX-11C	90-93	32A	47mm	40.8mm	26mm	<a href="#">020-439</a>
Kawasaki ZX-9R	94-97	32A	47mm	40.8mm	26mm	<a href="#">020-439</a>
KTM LC4		32A	47mm	40.8mm	26mm	<a href="#">020-439</a>
Kawasaki ZX-11D	93-01	32B	47mm	40.8mm	46mm	<a href="#">020-425</a>
Moto Guzzi		33F	46mm	40mm	32mm	---
Suzuki SV650	99-02	33B	46mm	40mm	31mm	<a href="#">020-489</a>
Suzuki GSX-R750 Air cooled	88-92	33B	46mm	40mm	31mm	<a href="#">020-489</a>
Suzuki GSX-R750 Water cooled	93-95	41TB	46mm	40mm	31mm	<a href="#">020-452</a>
Suzuki GSX-R750 Water cooled	96-97	33H	46mm	39.5mm	22mm	<a href="#">020-447</a>
Suzuki GSX-R1100 Water cooled	93-98	869	41.50mm	37.50mm	31mm	<a href="#">020-456</a>
Yamaha FZR1000	89-95	33A	46mm	37.50mm	40mm	<a href="#">020-426</a>
Yamaha YZF-R1	98-99	33J	46mm	40mm	35.50mm	<a href="#">020-486</a>
BMW R100		874	52mm	41.50mm	29.30mm	<a href="#">020-465</a>
Yamaha SR500	79-81	879	41.70mm	37.50mm	28mm	<a href="#">020-467</a>
Honda CBR1100XX Blackbird		32D	50mm	41.50mm	26mm	<a href="#">020-475</a>
KTM 950		32D	50mm	41.50mm	26mm	<a href="#">020-475</a>
Kawasaki ZX-10		863	42mm	36.80mm	26mm	<a href="#">020-461</a>
Suzuki LT-Z400	03-07	863	42mm	36.80mm	26mm	<a href="#">020-461</a>
Kawasaki Zephyr/ZRX1200		863	42mm	36.80mm	26mm	<a href="#">020-461</a>



# KEIHIN FCR Cable Mounting Brackets



## Cable Mounting Brackets For FCR Sold each.

### BMW

Model	Application	Keihin No.	Order No.
BMW	35-41mm	1190-981-2100	<b>021-129</b>
BMW (Dual)	37-39mm	1190-A33-2200	<b>021-134</b>

### Ducati

Ducati Single/ Dual	35-41mm	1190-981-2300	<b>021-132</b>
---------------------	---------	---------------	----------------

### FCR Single Carburetor

Single Carb 30° deg.	35-41mm	1190-A33-2300	<b>021-549</b>
----------------------	---------	---------------	----------------

### Harley Davidson®

H-D Evo CV Carb (for stock cable)	41mm	1190-B12-2100	<b>021-551</b>
--------------------------------------	------	---------------	----------------

### Honda

XR250R	35-41mm	1190-A33-2100	<b>021-133</b>
Single Carb 30° degree			
TRX400EX ATV	39-41mm	1190-A33-2200	<b>021-134</b>
CBR600F Hurricane	32-33mm	1190-979-2200	<b>021-127</b>
CBR600F2 Hurricane	32-33mm	1190-979-2300	<b>021-126</b>
CBR600F3 Hurricane	32-33mm	1190-979-2300	<b>021-126</b>
CBR600F3 Hurricane	35-41mm	1190-981-2200	<b>021-131</b>
XR600R	41mm	1190-A33-2200	<b>021-134</b>
XR650R Left Bellcrank	35-41mm	1190-B84-2100	<b>021-552</b>
CBR900RR	35-41mm	1190-981-2200	<b>021-131</b>
CB1000	35-41mm	1190-981-2200	<b>021-131</b>

### Kawasaki

ZX-6	35-41mm	1190-981-2100	<b>021-129</b>
ZX-7 (91-96)	35-41mm	1190-988-2100	<b>021-122</b>
ZX-9R	35-41mm	1190-988-2100	<b>021-122</b>
ZX-10	35-41mm	1190-981-2100	<b>021-129</b>
ZX-11	35-41mm	1190-981-2100	<b>021-129</b>
ZR1100 Zephyr	37-41mm	1190-981-2100	<b>021-129</b>
VN1500 Vulcan 1500	35-41mm	1190-988-2200	<b>021-249</b>

### KTM

Model	Application	Keihin No.	Order No.
KTM 950 Twin	35-41mm	1190-981-2300	<b>021-132</b>
KTM single	35-41	1190-A33-2100	<b>021-133</b>
Single Carb 30° degree			

### Moto-Guzzi

Moto-Guzzi	34-41mm	1190-988-2200	<b>021-249</b>
------------	---------	---------------	----------------

### Suzuki Street

LT-Z400 Quad	34-41mm	1190-981-2100	<b>021-129</b>
SV650 (Front)	35-41mm	1190-981-2300	<b>021-132</b>
SV650 (Rear)	35-41mm	1190-A33-2200	<b>021-134</b>
Single Carb 15° degree			
GSX-R750 96-97	35-41mm	1190-A77-2000	<b>021-550</b>
GSX-R750 Air Cooled (all)	35-41mm	1190-981-2100	<b>021-129</b>
GSX-R Liquid Cooled	35-41mm	1190-988-2200	<b>021-249</b>

### Triumph

Triumph	35-41mm	1190-981-2100	<b>021-129</b>
---------	---------	---------------	----------------

### Yamaha

FZR400	32-33mm	1190-979-2102	<b>021-125</b>
SR500	35-41mm	1190-A33-2100	<b>021-133</b>
Single Carb 30° degree			
FZR600	32-33mm	1190-979-2102	<b>021-125</b>
YZF600R	32-33mm	1190-979-2102	<b>021-125</b>
YZF600R	35-41mm	1190-981-2200	<b>021-131</b>
YZF-R6	35-41mm	1190-988-2100	<b>021-122</b>
YFM660 Raptor	39-41mm	1190-A33-2200	<b>021-134</b>
FZR750R	35-41mm	1190-981-2200	<b>021-131</b>
FZR1000R	35-41mm	1190-981-2200	<b>021-131</b>
YZF1000R	35-41mm	1190-981-2200	<b>021-131</b>
YZF-R1	35-41mm	1190-981-2200	<b>021-131</b>

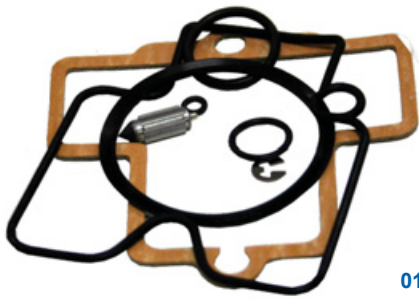

018-866



018-860

## Sudco Keihin FCR Carburetor Rebuild Kits

Each kit contains genuine KEIHIN parts to rebuild one Keihin Flat-CR Smoothbore carburetor body. Order per kit needed, one or more depending on number of carbs on bike. **Made in Japan.**

**H** - Horizontal Carburetor

**D** - Downdraft Carburetor

### Keihin Flat CR Downdraft

Application	Order No.
28-33 FCR-D	018-865
35-39 FCR-D	018-866
41 FCR-D	018-867

### Keihin Flat CR Horizontal

28-33 FCR-H	018-865
35-39 FCR-H	018-870
41 FCR-H	018-871

### Keihin FCR-MX Horizontal

FCR-MX37, 39, 41	020-319
FCR-MX37, 39, 41 w/ Air Cut-Off Valve/Hot Start	020-320
FCR-MX37, 39, 41 w/ Air Cut-Off Valve/Hot Start/TPS	020-321

## Sudco Accelerator Pump Rebuild Kit for Keihin FCR Carburetors

Genuine "KEIHIN" replacement parts. Kits include diaphragm, spring, "u-ring," o-ring, and 4 x 8mm screws. Kits available for Keihin Downdraft & Horizontal carbs and Keihin FCR-MX carb. **Made in Japan.**

### Keihin FCR Downdraft & Horizontal Carb all

Order No. **018-860**

Accelerator Pump Rebuild Kit - 8 piece Kit

Qt	OEM Reference	Description
Qt1	1201-858-2400	Diaphragm
Qt1	1300-142-2000	Spring
Qt1	W9353-36000	U Ring
Qt1	W9351-19058	O-Ring
Qt1	1028-825-2001	Rubber Cap
Qt3	0136-808-1100	4 x 8mm Screw



## Sudco Methanol Conversion Kit

This Methanol Kit from Sudco includes all the necessary components: main jets, needles, needle valves, etc. All the jetting required to convert your Keihin FCR carburetor to methanol usage.

Sold as a kit. **Note: Requires experienced tuner or technician familiar with rejetting for methanol usage.**

Application	Order No.
32-33 FCR Downdraft & Horizontal	018-858
35-41 FCR Downdraft & Horizontal	018-859

## Keihin FCR Needle Valve Seats

Valve Seat diameter should be determined according to maximum fuel flow and fuel pressure. Valve Seat only, Sold each.

### All Downdraft FCR

Size	Keihin No.	Order No.
1.00	N361-03-1.00	021-218
1.20	N361-03-1.20	021-219
1.40	N361-03-1.40	021-220
1.60	N361-03-1.60	021-221
1.80	N361-03-1.80	021-222
2.00 (Std)	N361-03-2.00	021-223
2.20	N361-03-2.20	021-224
2.40	N361-03-2.40	021-225
2.60	N361-03-2.60	021-226
O-Ring, Valve Seat	16958-397-7710-M1	021-047
Screw, Valve Seat	0118-804-1100	021-049
Float Valve (Needle Valve)	16155-ZG8-L100	018-676
Clip, Float Valve	0405-019-1000	018-674

### All Horizontal FCR

3.20 (Std)	N361-04-3.20	021-240
3.40	N361-04-3.40	021-241
3.60	N361-04-3.60	021-242
3.80 (Std on singles)	N361-04-3.80	021-243
4.00	N361-04-4.00	021-244
O-Ring, Valve Seat	16958-397-7710-M1	021-047
Screw, Valve Seat	0118-806-1100	021-250
Float Valve (Needle Valve)	1062-814-2100	018-504
Clip, Float Valve	0405-019-1000	018-674

# KEIHIN FCR-MX Carburetors



FCR-MX



FCR-MX with Air Cut Valve & Hot Start



FCR-MX with Air Cut Valve, Hot Start & TPS

## Keihin FCR-MX Series Off-Road Racing Carburetor

The ultimate for off-road performance. Keihin has developed an FCR carburetor designed for the specialized needs of the off-road racer. The FCR-MX carburetor has many new features to take motocross and ATV performance to the next level. These are some of the unique features of the Keihin FCR-MX for off-road applications:

- Over-flow drain joint and Tube
- Hot re-start knob
- Throttle Cable enclosure
- High capacity float chamber
- Air Cut-Off Valve (ACV) for de-acceleration enrichment (only on FCR-MX carburetors listed)
- Float chamber baffle for rough terrain
- Quad Vents

## FCR-MX Sizing Guide

Venturi Size	Engine Size
37mm	250cc - 375cc
39mm	350cc - 500cc
41mm	450cc and larger

## FCR-MX Standard Jetting Specifications

Carburetor	Main Jet	Main Air Jet	Slow Jet	Slow Air Jet	Jet Needle	Throttle Vlv. Cutaway	Needle Valve Seat	Float Height	Order No.
FCR-MX37	#160	#200	#45	#100	OC-EMR	1.5	3.8	9mm	<a href="#">016-915</a>
FCR-MX37 w/Air Cut Valve/Hot Start	#160	#200	#45	#100	OC-EMR	1.5	3.8	9mm	<a href="#">016-916</a>
FCR-MX37 w/Air Cut Valve/Hot Start/TPS	#160	#200	#45	#100	OC-EMR	1.5	3.8	9mm	<a href="#">016-917</a>
FCR-MX39	#160	#200	#45	#100	OC-EMR	1.5	3.8	9mm	<a href="#">016-925</a>
FCR-MX39 w/Air Cut Valve/Hot Start	#160	#200	#45	#100	OC-EMR	1.5	3.8	9mm	<a href="#">016-926</a>
FCR-MX39 w/Air Cut Valve/Hot Start/TPS	#160	#200	#45	#100	OC-EMR	1.5	3.8	9mm	<a href="#">016-927</a>
FCR-MX41	#160	#200	#48	#100	OC-EMR	1.5	3.8	9mm	<a href="#">016-935</a>
FCR-MX41 w/Air Cut Valve/Hot Start	#160	#200	#48	#100	OC-EMR	1.5	3.8	9mm	<a href="#">016-936</a>
FCR-MX41 w/Air Cut Valve/Hot Start/TPS	#160	#200	#48	#100	OC-EMR	1.5	3.8	9mm	<a href="#">016-937</a>



## Sudco FCR-MX Carburetor Rebuild Kits

Genuine KEIHIN replacement parts. Sold in kits.

Application	Order No.
FCR-MX37, 39, 41 FCR-MX	<a href="#">020-319</a>
FCR-MX37, 39, 41 with Air Cut-Off Valve/Hot Start	<a href="#">020-320</a>
FCR-MX37, 39, 41 with Air Cut-Off Valve/Hot Start/TPS	<a href="#">020-321</a>



## Keihin FCR-MX Pilot Screw

Stock replacement pilot screw for Keihin FCR-MX carburetors. Sold each.

Order No. [021-729](#)

Individual Parts (each)	Order No.
Spring	<a href="#">021-041</a>
Washer	<a href="#">021-045</a>
O-Ring	<a href="#">021-043</a>





## Sudco FCR-MX Accelerator Pump Rebuild Kit

Genuine KEIHIN replacement parts. Kit include diaphragm, spring, "u-ring", o-ring, rod, and 4 x 8mm screws. Sold kit.

Application	Order No.
FCR-MX37, 39, 41 - 8 Piece Kit	<b>018-861</b>

Qt	Contents	Keihin No.
1	Diaphragm	1201-858-2700
1	Spring	1300-142-2000
1	U-Ring	W9353-36000
1	O-Ring	W9351-19058
1	Rod	1458-858-201
3	4 x 8mm Screw	0136-808-1100



## Sudco FCR-MX Air Cut-Off Valve Set

Genuine KEIHIN replacement parts. Three piece set includes diaphragm, spring and u-ring.

Order No.
<b>018-900</b>

Qt	Contents	Keihin No.
1	Diaphragm	W1470-MW0-7500
1	Spring	120-A19-2000
1	U-Ring	W9353-36000



## Tokyomods FCR-MX Less Tension Throttle Spring

This low tension throttle return spring is designed to reduce the stiff feeling in your bike, or ATV throttle. Sold each.

Application	Year	Order No.
Keihin FCR-MX		<b>024-220</b>
Honda TRX450R	06-09	<b>024-221</b>



## Tokyomods FCR-MX Fuel Mixture Screw

Easily adjust the fuel mixture on your Keihin FCR carburetor. Dual O-rings to keep it in place. Machined from 6061 aluminum.

Application	Color	Order No.
Keihin FCR-MX	Red	<b>024-200R</b>
Keihin FCR-MX	Blue	<b>024-200B</b>
Keihin FCR-MX	Black	<b>024-200K</b>
Keihin FCR-MX	Mag	<b>024-200M</b>



024-210M



024-210R

## Tokyomods FCR-MX Billet Hot Start Nut

Replaces fragile plastic stock nut, and includes new o-ring. Machined from 6061 aluminum.

Application	Color	Order No.
Keihin FCR-MX	Red	<b>024-210R</b>
Keihin FCR-MX	Blue	<b>024-210B</b>
Keihin FCR-MX	Black	<b>024-210K</b>
Keihin FCR-MX	Mag	<b>024-210M</b>



## Tokyomods FCR-MX Sump (Drain Plug)

Keeps all fuel contaminates including water away from the main jet, helps control fuel slosh and bogging, won't get distorted from over tightening, and easy to reach for quicker jetting changes. Machined from 6061 aluminum. Also fits Keihin PJ, PWK, PWM, and PE carbs.

Application	Color	Order No.
Keihin FCR-MX	Red	<b>024-230R</b>
Keihin FCR-MX	Blue	<b>024-230B</b>
Keihin FCR-MX	Black	<b>024-230K</b>
Keihin FCR-MX	Mag	<b>024-230M</b>

# KEIHIN FCR-MX Exploded View

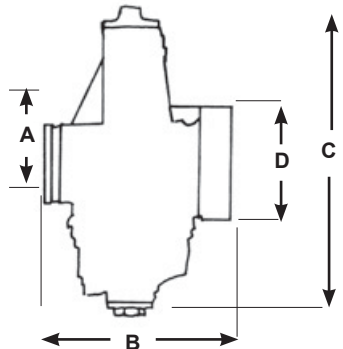
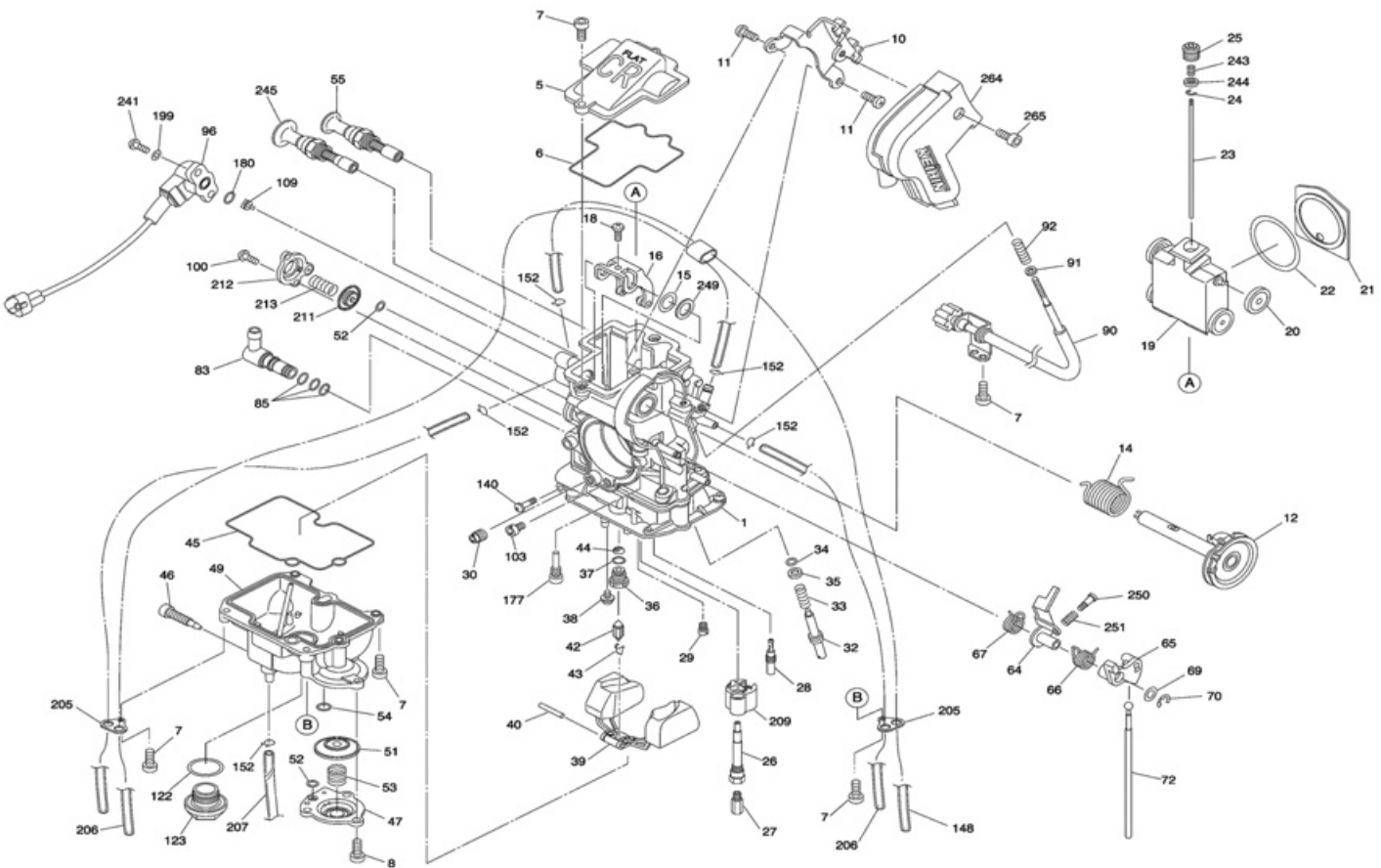

**Float Height**  
**9mm**

## FCR-MX Replacement Parts

Applications: FCR-MX37, FCR-MX39, FCR-MX41.

No.	Description	Application	Keihin No.	Order No.
5.	Top Cover	All	1030-897-2000	<a href="#">021-710</a>
6.	Gasket, Top Cover	All	1202-895-6000	<a href="#">021-711</a>
7.	Screw M4 x 12mm	All	0136-806-1100	<a href="#">021-700</a>
8.	Screw M4 x 8mm	All	0136-808-1100	<a href="#">021-010</a>
10.	Bracket	All	1190-840-2101	<a href="#">021-712</a>
			1190-B40-2100	
11.	Screw 5 x 8mm	All	93500-05008-1H	<a href="#">021-713</a>
12.	Throttle Shaft	All	5025-B35-2201	<a href="#">021-714</a>
14.	Coil Spring	All	1305-A83-2000	<a href="#">021-718</a>
15.	Washer	All	0301-092-700	<a href="#">021-018</a>
16.	Link Arm Complete	All	1061-831-2101	<a href="#">021-721</a>
18.	Stop Screw	All	4110-825-1100	<a href="#">021-723</a>
19.	Throttle Valve	All	N501-49C01	<a href="#">021-320</a>
	(Throttle Valve requires qt1 of part #20, Roller <a href="#">021-027</a> )			
20.	Roller	All	1119-803-7002	<a href="#">021-027</a>
21.	Vacuum Release Plate	All	1609-809-2100	<a href="#">021-725</a>
22.	Seal	All	1099-817-2001	<a href="#">021-033</a>
23.	Jet Needles	All	N427-OC-XXX	<a href="#">Pg.118</a>
24.	Clip, Jet Needle	All	0403-802-1000	<a href="#">018-616</a>
25.	Needle Set Screw	All	1421-802-2000	<a href="#">021-727</a>
26.	Main Nozzle	All	1154-842-2000	<a href="#">021-728</a>
27.	Main Jet	All	99101-357-XXX	<a href="#">Pg.150</a>
28.	Slow Jet	All	N424-21-XXX	<a href="#">Pg.148</a>
29.	Starter Jet	All	99101-393-XXX	<a href="#">Pg.150</a>
30.	Slow Air Jet	All	99101-124-XXX	<a href="#">Pg.149</a>
	Part #30 can be replaced with Slow Air Screw. <a href="#">Pg.149</a>			
30.	Slow Air Jet (some OEM)	All	N424-33-xxx	<a href="#">Pg.148</a>
32.	Pilot Screw	All	N446-26A00	<a href="#">021-729</a>
33.	Spring, Pilot Screw	All	1290-812-2001	<a href="#">021-041</a>

## FCR-MX Carburetor Dimensions

Size	A	B	C	D	Total Width
FCR-MX37	48	63.5	191.8	—	120.8
FCR-MX39	48	63.5	191.8	—	120.8
FCR-MX41	48	63.5	191.8	—	120.8



## FCR-MX Replacement Parts

Applications: FCR-MX37, FCR-MX39, FCR-MX41.

No.	Description	Application	Keihin No.	Order No.
34.	O-Ring, Pilot Screw	All	16075-KG8-9010-M1	021-043
35.	Washer, Pilot Screw	All	0301-803-2000	021-045
36.	Valve Seat <b>(will not work on some OEM)</b>			
	3.20	All	N361-043-3.20	021-240
	3.40	All	N361-043-3.40	021-241
	3.60	All	N361-043-3.60	021-242
	3.80	All (Std)	N361-043-3.80	021-243
	4.00	All	N361-043-4.00	021-244
37.	O-Ring, Valve Seat	All	16958-397-7710-M1	021-047
38.	Screw, Valve Seat	All	0118-806-1100	021-250
39.	Float	All	1052-856-2100	018-202
40.	Arm Pin	All	W9525-25250	018-670
42.	Float Valve	All	1062-814-2101	018-504
43.	Clip, Float Valve	All	0405-019-1000	018-674
44.	Fuel Screen	All	2009-811-2100	021-730
45.	Packing, Float Bowl	All	1202-896-6000	021-731
46.	Drain Screw	All	1198-810-2002	021-733
47.	Cover, Accel. Pump	All	1230-826-2002	021-057
49.	Float Bowl	All	1050-948-2101	021-734
49a.	Float Bowl w/leak jet Boss	All	1050-948-2101	021-734A
51.	Diaphragm	All	1201-858-2700	021-735
52.	U-Ring, Accel. Pump	All	W9353-36000	021-067
53.	Spring, Accel. Pump	All	1300-142-2000	021-069
54.	O-Ring, Accel. Pump	All	16178-548-0040	021-071
55.	Cold Starter Valve	All	1166-844-2100	021-737
64.	Link Lever	All	1100-914-2100	021-739
65.	Link Lever	All	1100-915-7000	021-740
66.	Coil Spring #1	All	1305-B01-2001	021-719
67.	Coil Spring #2	All	1305-A82-2000	021-717
69.	Washer	All	W1795-223-9900	021-741
70.	E-Clip	All	16179-676-3000	021-742
72.	Rod	All	1458-858-2001	021-743
83.	Fuel Joint	All	1074-892-2100	021-744
85.	O-Ring, Fuel Joint	All	W9351-13057	018-755
90.	Idle Speed Screw	All	1034-815-4500	021-745
91.	Washer	All	0301-078-1200	021-101
92.	Spring	All	1300-112-2000	021-103
96.	Throttle Position Sensor (TPS)	All	1614-862-2100	021-746
100.	Screw M4 x 8mm	All	0136-804-1100	021-105
103.	Main Air Jet	All	99101-393-xxx	Pg.150
109.	Collar	All	16145-MZ2-7800	021-747
122.	O-Ring	All	16173-001-0040	018-664
123.	Drain Bolt	All	16162-ND4-7511-M1	018-128
140.	Screw	All	0110-804-1200	021-749
148.	Vent Hose	All	0803-884-0100	021-751
152.	Hose Clip	All	W9535-3500	018-098
177.	Stop Screw	All	1034-905-2000	021-722
180.	O-Ring	All	16978-ZB9-0050	021-732
199.	Washer	All	0301-261-36G5	021-753
205.	Hose Retainer	All	16179-KZ4-6900	018-505
206.	Vent Hose	All	0803-878-0000	021-750
207.	Vent Hose	All	95003-07033-31	021-752
209.	Buffer Plate	All	1157-812-7000	021-754
211.	Diaphragm	All	W1470-MW0-7500	021-736
212.	Cover	All	1230-850-2000	021-755
213.	Spring	All	1290-A19-2000	021-715
241.	Screw (Torx)	All	0137-261-36G5	021-757
243.	Spring	All	1290-A65-2000	021-716
244.	Collar	All	1118-B36-2000	021-748
245.	Hot Start Valve	All	1166-845-2100	021-738
249.	Washer	All	W1795-164-9900	021-758
250.	Stop Screw	All	16124-KR3-6010-M1	021-724
251.	Coil Spring	All	16053-KT7-0030	021-720
264.	Cover	All	1230-869-7001	021-756
265.	Cover Screw	All	0136-839-1100	021-759

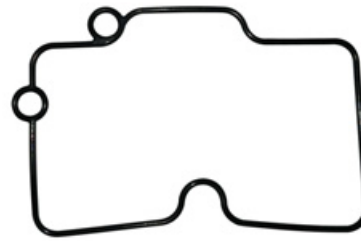

## Sudco OEM FCR-MX Float Bowl O-Ring

Genuine KEIHIN replacement part. Sold each. *Made in Japan*

Order No. **021-731**

### Honda

Application	Year
CRF250R	04-09
CRF250X	04-09
CRF250X	2012
CRF450R	02-08
CRF450X	05-09
CRF450X	2012

### Kawasaki

KX250N1/N2 (KX250F)	04-05
KX250T6F/T7F/T8F/W9F/XAFB (KX250F)	06-10
KLX450A8F/A9F	08-09
KX450D6F/D7F/D8F (KX450F)	06-08

### KTM

250 SX-F	05-10
250 SXS	2004
250 XC-F Cross Country	07-09
250 XC-W Enduro	06-09
250 XC-W Champions Edition	2010
250 XC-W Six Days	2011
400 EXC-G Racing	04-06
400 EC-W	07-09
450 EXC	10-11
450 EXC-G Racing	04-06
450 EXC-R	2008
450 SMR Supermoto	06-09
450 SX (RFS)	04-06
450 SX-F	07-12
450 XC Cross Country	06-07
450 XC-F	08-09
450 XC-W	09-11

### Suzuki

RM-Z250K4-L0	04-10
RM-Z450K5/K6/K7	05-07

### Yamaha

WR250FN-FY	02-09
WR250FA/FB	11-12
YZ250FN-FDL/FDW (YZ250F)	02-13
WR400FM	2000
WR426FN/FP	01-02
YZ426FM/FN/FP (YZ426F)	00-02
WR450FR/FS/FT/FV/FW/FX/FY	03-11
YZ450FR/FS/FT/FV/FW/FX (YZ450F)	03-08
YZ450FXL/FXW/FYL/FYW (YZ450F)	08-09
YZ450FSPV 50Th Anniversary	2006



## N427-90 FCR 28-33mm

- E**  
Taper
- T**  
L1
- V**  
Diameter

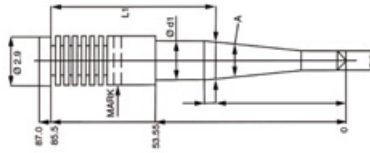

Operations affected by needle selection

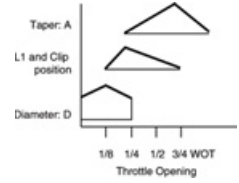

		Rich ← 1/8 to 1/4 Throttle → Lean										
		Diameter (d-1)mm										
		M=2.715 N=2.725 P=2.735 R=2.755 S=2.765 T=2.775 U=2.785 V=2.795										
Taper (A) in degrees	(L1)Length in mm	RICH ↕ LEAN										
E 1° 0'	B=58.70	RICH ↕ LEAN										
	K=62.30											
	T=65.90											
F 1° 15'	B=58.70	RICH ↕ LEAN										
	K=62.30											
	T=65.90											
G 1° 30'	B=58.70	RICH ↕ LEAN										
	K=62.30											
	T=65.90											

## N427-0C FCR 35-41mm, FCR-MX

- E**  
Taper
- M**  
L1
- P**  
Diameter

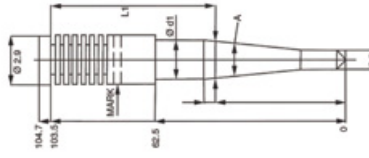

Operations affected by needle selection

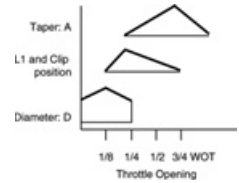

		Rich ← 1/8 to 1/4 Throttle → Lean													
		H=2.675 K=2.695 L=2.705 M=2.715 N=2.725 P=2.735 Q=2.745 R=2.755 S=2.765 T=2.775 U=2.785 V=2.795 W=2.805													
Taper (A) in degrees	(L1)Length in mm	RICH ↕ LEAN													
D 0° 45'	B=74.65	RICH ↕ LEAN													
	F=76.45														
	H=77.35														
	K=78.25														
	L=78.70														
E 1° 0'	M=79.15	RICH ↕ LEAN													
	V=82.75														
	B=74.65														
	F=76.45														
	H=77.35														
F 1° 15'	K=78.25	RICH ↕ LEAN													
	L=78.70														
	M=79.15														
	V=82.75														
	B=74.65														
G 1° 30'	F=76.45	RICH ↕ LEAN													
	H=77.35														
	J=77.80														
	K=78.25														
	L=78.70														

## Keihin FCR Throttle Cables

Throttle cables designed to fit Keihin FCR carburetors.  
Available in Kits (throttle with push/pull cables), Push/Pull Cable Sets, Throttle only and individual push or pull cable.



### Ducati

Application	Year	Throttle with Push/Pull Cables (Kit)	Push/Pull Throttle Cable Set	Push/Pull Throttle Only	Pull Throttle Cable Only	Push Throttle Cable Only
750/900SS with dual carbs	93-95	021-285	021-285A	021-280	_____	_____
M900 Monster with dual carbs		021-286	021-286A	021-280	_____	_____
SS/M900 Monster (Singles)		021-284	021-284A	021-280	_____	_____

### Dinosaur Class Superbikes with Tubular Handlebars

Dinosaur Class (Vintage)	005-230	_____	005-230C	005-230A	005-230B
--------------------------	---------	-------	----------	----------	----------

### Honda

CBR600F	87-90	_____	_____	_____	_____
CBR600F2 Hurricane	91-94	_____	021-294	_____	021-294A 021-294B
XR600R		_____	021-298	_____	021-298A 021-298B
XR650L Dual Sport	93-	_____	021-903	_____	021-903A 021-903B
XR650R	00-	_____	021-945	_____	021-945A 021-945B
CBR900RR	93-99	_____	021-295	_____	021-295A 021-295B

### Kawasaki

ZX600F Ninja ZX-6R	95-97	_____	021-900	_____	021-900A 021-900B
ZX600 Ninja ZX-6R	2000	_____	021-901	_____	_____
ZX7 Ninja ZX-7	96-99	_____	021-282	_____	021-282A 021-282B
ZX900B Ninja ZX-9R	94-97	_____	021-282	_____	021-282A 021-282B
ZX900 Ninja ZX-9R	98-00	_____	021-901	_____	_____
ZX1100C Ninja ZX-11	90-93	_____	021-268	_____	021-268A 021-268B
ZX1100D Ninja ZX-11	93-01	_____	021-268	_____	021-268A 021-268B

### KTM

620RXC & Duke with unitized throttle kill assembly.		_____	021-291	_____	021-291A 021-291B
620RXC & Duke with separate kill assembly.		_____	021-281	021-280	_____
950 Adventure		_____	_____	021-965	_____

### Moto-Guzzi

1100 Sport		_____	021-905	_____	021-905A 021-905B
------------	--	-------	---------	-------	-------------------

### Norton

750/850 Commando		_____	021-940	021-280	_____
------------------	--	-------	---------	---------	-------

### Suzuki

GSX-R600W	92-93	_____	021-297	_____	021-297A 021-297B
GSX-R600	97-99	_____	021-267	_____	021-267A 021-267B
RF600	94-96	_____	021-288	_____	021-288A 021-288B
SV650		_____	021-932	_____	021-932A 021-932B
GSX-R750 air cooled	89-92	_____	021-281	021-280	_____
GSX-R750W	93-95	_____	021-297	_____	021-297A 021-297B
GSX-R750	96-97	_____	021-267	_____	021-267A 021-267B
RF900	94-97	_____	021-288	_____	021-288A 021-288B
GSX-R1100 air cooled	89-92	_____	021-281	021-280	_____
GSX-R1100W	93-98	_____	021-297	_____	021-297A 021-297B

### Universal

Sportbike		_____	021-281	021-280	_____
ATV & Dirtbike		_____	021-281.5	021-280	_____

### Yamaha

FZR400R	88-90	_____	021-290	_____	021-290A 021-290B
FZR600	89-99	_____	021-290	_____	021-290A 021-290B
YZF600R	94-95	_____	021-293	_____	_____
Rhino 660		_____	021-963	_____	_____
FZR750R	87-88	_____	021-292	_____	021-292A 021-292B
FZR1000R	87-90	_____	021-292	_____	021-292A 021-292B
FZR1000R	91-95	_____	021-293	_____	_____
YZF-R1		_____	021-930	_____	_____



## Sudco FCR Air Cleaner/Airbox Adapters Sold each.

Carburetor Venturi Size (mm)	Filter Mounting Flange Dimension	Length	Order No.	Carburetor Venturi Size (mm)	Filter Mounting Flange Dimension	Length	Order No.
FCR28 - FCR33	2-1/4" (57mm)	28mm	<a href="#">021-211</a>	FCR35 - FCR41	Raptor (O.D.52mm)	27mm	<a href="#">021-600</a>
FCR35 - FCR41	2-7/16" (66mm oval)	28mm	<a href="#">021-212</a>	FCR35 - FCR41	FCR to H-D CV 3 Bolt Big Twin	34mm	<a href="#">021-601</a>
FCR35 - FCR41	2-1/4" (57mm)	40mm	<a href="#">021-213</a>	FCR35 - FCR41	883/1200 Sportster	31.5mm	<a href="#">021-601A</a>
FCR35 - FCR41	2 bolt to Kawasaki Airbox	39mm	<a href="#">021-214</a>	FCR35 - FCR41	TRX450/XR650R	49mm	<a href="#">021-612</a>
FCR35 - FCR41	2-11/16" (68mm)	28mm	<a href="#">021-215</a>		(O.D.62.4mm)		
FCR35 - FCR41	2-3/8" (60.3mm)	26mm	<a href="#">021-216</a>	FCR35 - FCR41	YFZ450 (O.D. 58.3mm)	23.5mm	<a href="#">021-613</a>
FCR35 - FCR41	(58.8mm)	26mm	<a href="#">021-216A</a>	FCR35 - FCR41	FCR-MX OEM (O.D. 56mm)	21.5mm	<a href="#">021-614</a>

## Sudco FCR Air Filter Applications

### Ducati

Model	Year	FCR Carb (mm) Venturi Size	Air Filter Adapter	Qt Req'd	K&N Ref.	Order No.	(Comments)	Qt Req'd
750/900SS Supersport	91-99	39, 41mm	<a href="#">021-212</a>	2	DU-0900	<a href="#">005-192</a>	fits stock airbox	1
M750/M900 Monster	95-99	39, 41mm	<a href="#">021-212</a>	2	DU-0900	<a href="#">005-192</a>	fits stock airbox	1

### Honda

XR250R	all	35mm	<a href="#">021-213</a>	1	HA-1312	—	fits stock airbox	—
TRX400EX	all	39, 41mm	<a href="#">021-213</a>	1	—	—	fits stock airbox	—
TRX450R	04-05	39, 41mm	<a href="#">021-612</a>	1	—	—	fits stock airbox	—
XR600R	89-99	39, 41mm	<a href="#">021-213</a>	1	HA-1312	—	fits stock airbox	—
XR650L	93-97	41mm	<a href="#">021-216</a>	1	—	—	fits OEM filter	—
XR650R	00-04	41mm	<a href="#">021-612</a>	1	—	—	fits OEM filter	—
CBR600F Hurricane	87-90	32, 33mm	<a href="#">021-211</a>	4	RU-3000	<a href="#">005-178</a>	individual pods	2
					RU-3010	<a href="#">005-179</a>	individual pods	2
CBR600F2 Hurricane	91-94	32, 33mm	<a href="#">021-211</a>	4	RU-3000	<a href="#">005-178</a>	individual pods	2
					RU-3010	<a href="#">005-179</a>	individual pods	2
CBR600F2 Hurricane	91-94	32, 33mm	<a href="#">021-211</a>	4	RU-2852	<a href="#">005-187</a>	dual filter kit	1
CBR600F2 Hurricane	91-94	35mm	<a href="#">021-212</a>	4	RU-2952	<a href="#">005-174</a>	dual filter kit	1
CBR600F2 Hurricane	95-98	35mm	<a href="#">021-212</a>	4	RU-2952	<a href="#">005-174</a>	dual filter kit	1
CBR900RR	94-99	39, 41mm	<a href="#">021-212</a>	4	RU-2952	<a href="#">005-174</a>	dual filter kit	1
CBR1100XX Blackbird		39, 41mm	<a href="#">021-212</a>	4	RU-2952	<a href="#">005-174</a>	dual filter kit	1

### Kawasaki

KLX250R (kickstart)	94-96	35mm	<a href="#">021-213</a>	1	—	—	fits stock airbox	—
KLX250S with electric start	07-08	35mm	<a href="#">021-216</a>	1	—	—	fits stock airbox	—
KLX300R (kickstart)	97-07	35mm	<a href="#">021-213</a>	1	—	—	fits stock airbox	—
ZX6D, ZX6E	88-97	35mm	<a href="#">021-212</a>	4	RU-2952	<a href="#">005-174</a>	dual filter kit	1
ZX600F Ninja ZX-6R	95-97	35mm	<a href="#">021-214</a>	ram air 4	KA-6095	<a href="#">005-395</a>	fits stock airbox	1
KLX650	all	41mm	<a href="#">021-216</a>	1	—	—	fits stock airbox	—



## FCR Air Cleaner Adapter O-ring

to be used with FCR35-41mm air filter adapters. **\*\*Highly recommended for Off-Road and RAM Air applications.**

Order No. **021-439**

## Sudco FCR Air Cleaner/Airbox Adapters Sold each.

### Kawasaki

Model	Year	FCR Carb (mm) Venturi Size	Air Filter Adapter	Qt Req'd	K&N Ref.	Order No.	(Comments)	Qt Req'd
ZX750 ZX7R	96-99	39, 41mm	<b>021-214</b> ram air	4	KA-7598	_____	fits stock airbox	_____
ZX900 ZX-9R	94-99	39, 41mm	<b>021-214</b> ram air	4	_____	_____	_____	_____
ZX1000B ZX-10	88-90	37, 39, 41mm	<b>021-212</b>	4	RU-2952	<b>005-174</b>	dual filter kit	1
ZX1100C ZX-11	90-93	37, 39, 41mm	<b>021-214</b> ram air	4	KA-0004	_____	fits stock airbox	_____
ZX1100D ZX-11	93-99	37, 39, 41mm	<b>021-214</b> ram air	4	KA-0010	_____	fits stock airbox	_____
ZX1100D ZX-11 (race cars only)		37, 39, 41mm	<b>021-212</b>	4	RU-2952	<b>005-174</b>	dual filter kit	1
ZRX1100A Zephyr	99-00	39, 41mm	<b>021-216</b>	4	RU-2922	<b>005-184</b>	dual filter kit	1

### KTM

LC4 400RXC/ 600RXC	all	39, 41mm	<b>021-212</b>	1	_____	_____	use OEM filter	_____
950 Adventurer	03-07	39, 41mm	<b>021-212</b>	1	_____	_____	dual filter kit	_____

### Moto-Guzzi

Sport 1000 (carbureted models)	94-97		<b>021-600</b>	2	_____	_____	use OEM filter	_____
--------------------------------	-------	--	----------------	---	-------	-------	----------------	-------

### Suzuki

DR350S	90-99	35mm	<b>021-216</b>	1	_____	_____	stock airbox	_____
DRZ400	00-07	39, 41mm	<b>021-216</b>	1	_____	_____	stock airbox	_____
LT-Z400	04-06	39, 41mm	<b>021-216A</b>	1	_____	_____	stock airbox	_____
GSX-R600	1993	39, 41mm	<b>021-216</b>	4	RU-3092	<b>005-340</b>	dual filter kit	1
SV650	99-02	39, 41mm	<b>021-215</b>	2	SU-6599	<b>005-639</b>	fits stock airbox	2
SV650	99-02	39, 41mm	<b>021-216A</b>	2	RU-0800	<b>005-116</b>	individual pods	2
GSX-R750 (air cooled)	86-92	39, 41mm	<b>021-216</b>	4	RU-2922	<b>005-184</b>	dual filter kit	1
GSX-R750W (liquid cooled)	93-95	37, 39, 41mm	<b>021-216</b>	4	RU-3092	<b>005-340</b>	dual filter kit	1
GSX-R750	96-97	35, 39, 41mm	<b>021-215</b> ram air	4	SU-7596	<b>005-345</b>	fits stock airbox	1
GSX-R1100 (air cooled)	86-92	39, 41mm	<b>021-216</b>	4	RU-2922	<b>005-184</b>	dual filter kit	1
GSX-R1100 (liquid cooled)	93-97	37, 39, 41mm	<b>021-216</b>	4	RU-3092	<b>005-340</b>	dual filter kit	1
GSF1200	97	39, 41mm	<b>021-216</b>	4	RU-2922	<b>005-184</b>	dual filter kit	1

### Triumph

DOHC Triple	94-96	39mm	<b>021-212</b>	3	RU-2780	<b>005-188</b>		3
-------------	-------	------	----------------	---	---------	----------------	--	---

### Yamaha

FZR400	88-89	32, 33mm	<b>021-211</b>	4	RC-2890	<b>005-170</b>	individual pods	2 each
					RC-2900	<b>005-171</b>	individual pods	2 each
YZF450		39, 41mm	<b>021-613</b>	1	_____	_____	fits stock airbox	_____
FZR600	89-96	32, 33mm	<b>021-211</b>	4	RC-2890	<b>005-170</b>	individual pods	2 each
					RC-2900	<b>005-171</b>	individual pods	2 each
YZF600	95-89	33mm	<b>021-211</b>	4	RC-2890	<b>005-170</b>	individual pods	2 each
					RC-2900	<b>005-171</b>	individual pods	2 each
YZF-R6		35mm	<b>021-600</b>	4	RU-0981	<b>005-744</b>	individual pods	4
YZF750	94-97	39, 41mm	<b>021-216</b>	4	RU-3092	<b>005-340</b>	dual filter kit	1
TDM850, TRX850	all	39, 41mm	<b>021-216</b>	2	YA-7585	_____	fits stock airbox	1
FZR1000	87-95	37, 39, 41mm	<b>021-216</b>	4	RU-3092	<b>005-340</b>	dual filter kit	1
FZR1000	87-88	37, 39, 41mm	<b>021-212</b>	4	RU-0800	<b>005-116</b>	single filter	4
YZF1000R	1997	39, 41mm	<b>021-215</b> fits stock	4	YA-1089	<b>005-585</b>	fits stock airbox	1
YZF-R1	98-99	39, 41mm	<b>021-215</b> fits stock	4	YA-1098	<b>005-637</b>	fits stock airbox	1

# KEIHIN CR Special Racing Carburetors



## Keihin Roundslide CR Sidedraft Racing Carburetors

The choice of Team Honda for years on all there in-line 4-cylinder race bikes in Superbike, World Championship Endurance and Formula One classes. You'll find the power you need with these Keihin Roundslide CR carburetors. Designed for use on sidedraft four-stroke motorcycle engines. Features include: Improved throttle response; direct linkage to slides provides more precise control than vacuum slide carburetors. A 10% horsepower gain can be expected; Smooth venturi design produces stronger power than original equipment carburetors using butterfly throttle valves. Race fuel capability. Available for gasoline or alcohol use. Rejetting required when using alcohol or methanol, kit available as an option. Ready to bolt-on and run, these kits come complete with mounting spigots, velocity stacks and velocity stack covers. Available sizes: 26, 29, 31, 33, 35, 37 and 39mm. Intake length can be adjusted with optional mounting adapter spigots. Most replacement and tuning parts are available, please see CR Special exploded view, parts list and parts/accessories on [page 124-131](#).

### CR Special Sets (Call for applications not listed)

#### Honda

Model	Year	CR26	CR29	CR31	CR33	CR35
CB400F Super Sport	75-77	016-300	---	---	---	---
CB750F/K (SOHC)	77-78	---	016-3027	016-3052	---	---
CB750F (DOHC) Super Sport	79-82	---	016-3026	016-3051	016-3075	016-3100
CB750 (SOHC)	69-76	---	016-3025	016-3050	---	---
CB750K (DOHC)	79-82	---	016-3026	016-3051	016-3075	016-3100
CB900F Super Sport	80-82	---	---	016-3051	016-3076	016-3100
CB1100F Super Sport	1983	---	---	016-3051	016-3076	016-3100

#### Kawasaki

ZX600A Ninja 600R	85-87	---	---	016-3054	016-3082	---
ZX600B Ninja 600RX	1987	---	---	016-3054	016-3082	---
ZX600C Ninja 600R	88-97	---	---	016-3054	016-3082	---
KZ650B/C/D/E/F	77-80	---	016-3029	---	---	---
KZ750E/H/N	80-83	---	016-3029	---	---	---
ZX750F Ninja 750R	87-90	---	---	---	---	016-3105
Z1/A/B-900	73-75	---	016-3029	016-3055	016-3079	016-3103
KZ900A	76-77	---	016-3029	016-3055	016-3079	016-3103
KZ900B LTD	1976	---	016-3029	016-3055	016-3079	016-3103
ZX900A Ninja 900R	84-86	---	---	---	016-3083	016-3106
KZ1000	77-80	---	016-3029	016-3055	016-3079	016-3103
KZ1000JK/M	81-82	---	016-3030	016-3055	016-3080	016-3103
KZ1000R Replica	82-83	---	016-3030	016-3055	016-3080	016-3103
ZX1000A Ninja 1000R	86-87	---	---	---	016-3084	016-3106
KZ1100	81-83	---	016-3030	016-3055	016-3080	016-3103
KZ1100B GPz	81-82	---	016-3030	016-3055	016-3080	016-3103
ZX1100A GPz	83-84	---	016-3030	016-3055	016-3080	016-3103

**IMPORTANT:** Legal in California only for racing vehicles which may never be used upon a highway.



## Suzuki

Model	Year	CR26	CR29	CR31	CR33	CR35
GSX600F Katana		_____	_____	_____	016-3092	_____
GS750 2-Valve	77-79	_____	016-3033	_____	_____	_____
GS750E 2-Valve	80-82	_____	016-3033	_____	_____	_____
GS750L 2-Valve	79-81	_____	016-3033	_____	_____	_____
GS750ED/ESD 4-Valve	1983	_____	016-3034	016-3059	_____	_____
GS750T 4-Valve	82-83	_____	016-3034	016-3059	_____	_____
GS750SD Katana 4-Valve	1983	_____	016-3034	016-3059	_____	_____
GS850	80-83	_____	_____	016-3060	016-3090	_____
GS1000		_____	_____	016-3061	016-3090	016-3109
GS1100		_____	_____	_____	016-3090	_____
GSX1100		_____	_____	016-3061	016-3090	016-3110
GSX-R1100 Air Cooled	89-92	_____	_____	_____	_____	_____
GS1150	83-86	_____	_____	_____	016-3090	_____

## Yamaha

FJ600	84-85	_____	016-3037	*016-3064	_____	_____
				*Race motor only		
FZ600	86-88	_____	016-3037	*016-3064	_____	_____
				*Race motor only		
XJ650		_____	_____	016-3065	_____	_____
XJ1100 Maxim	1982	_____	_____	_____	016-3096	_____
XS1100		_____	_____	_____	016-3097	016-3113
FJ1100	84-85	_____	_____	_____	016-3096	016-3113
FJ1200	86-92	_____	_____	_____	016-3096	016-3113

## Keihin CR Dual Roundslide Racing Carburetors

Ready to bolt-on and run, these kits come complete with mounting spigots and velocity stacks, or can bolt up to a pod air filter system. Requires a push-pull throttle assembly, available as an option. Available sizes: 31, 33, 35, 37 and 39mm. Most replacement and tuning parts are available, please see CR Special exploded view and parts list on [page 124-125](#).



## CR Dual Carburetor Sets (Call for applications not listed)

## Honda

Model	Year	CR31	CR33	CR35	CR37
CB350K Super Sport (will not fit stock frame)		016-3200	_____	_____	_____
CB450K Super Sport	68-74	_____	016-3225	016-3250	016-3275
CB500T	75-76	_____	_____	_____	016-3275

## Kawasaki \*\*\*please specify model year when ordering

EX250 Ninja 250R *Race motor only		016-3205	_____	_____	_____
EX500		_____	016-3228	016-3253	016-3278

## Suzuki Street

GS500E	1989-	_____	016-3231	016-3256	016-3284
DR750		_____	_____	_____	_____

## Triumph

Bonneville	2001 on	_____	_____	016-3600	_____
------------	---------	-------	-------	----------	-------

## Yamaha

SRX600S/SC	1986	016-3210	016-3234	016-3259	016-3281
TT600K/L/N/S	83-86	016-3210	016-3234	_____	_____
XT600		016-3210	016-3234	_____	_____

# KEIHIN CR Special Exploded View

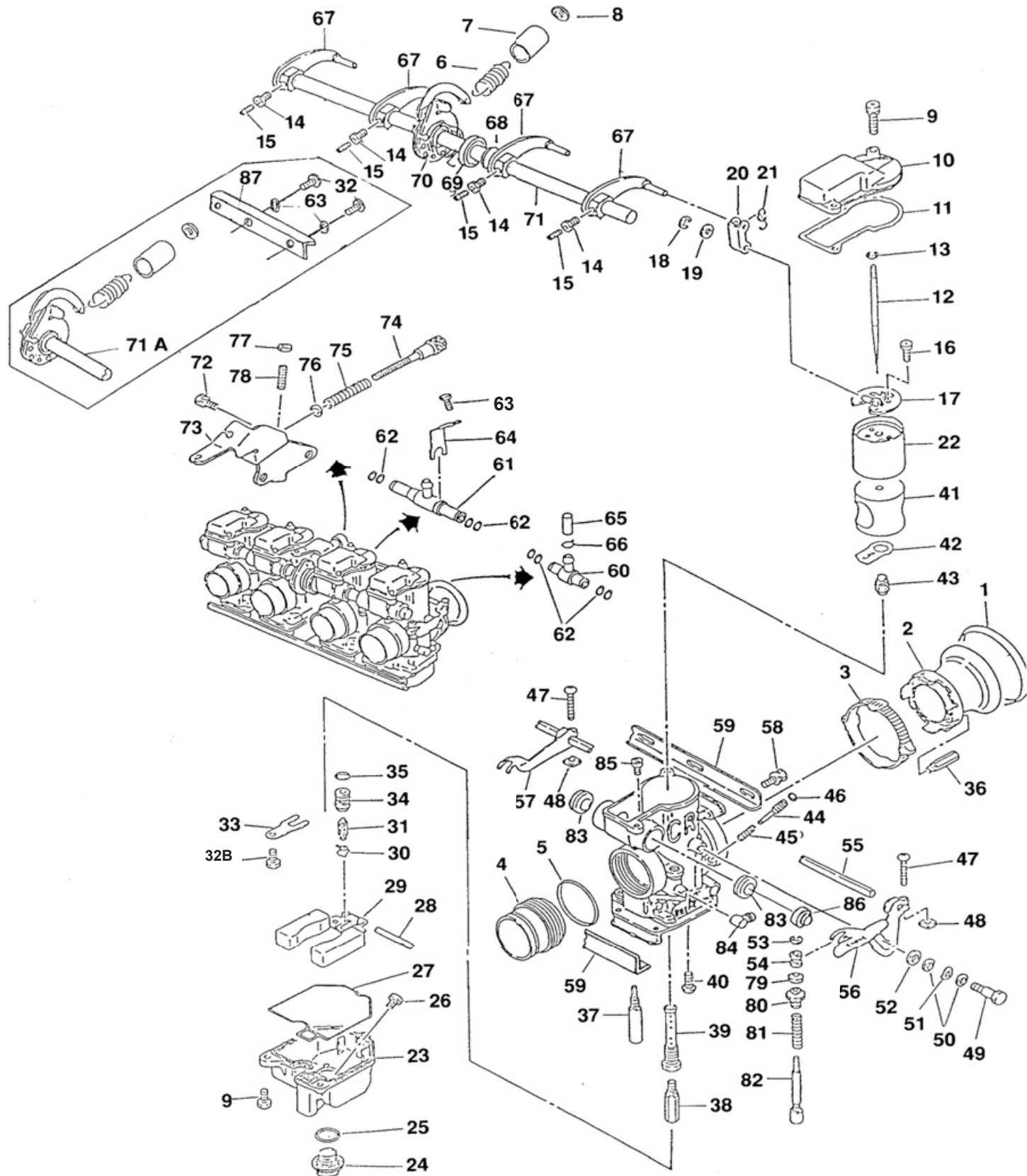

**Float Height**  
**14mm**

## CR Special (CRS) Replacement Parts

Applications: CR26, CR29, CR31, CR33, CR35, CR37, CR39.

Keihin Part No. highlighted in **BOLD RED** are included in rebuild kit.

No.	Description	Application	Keihin No.	Order No.
1.	Rubber Cap	26-33mm	R028-004-7000	<b>018-811</b>
		35-39mm	1028-809-7000	<b>018-810</b>
2.	Velocity Stack 45mm	26-33mm	1130-800-2001	<b>020-220</b>
	Velocity Stack 70mm	26-33mm	1130-801-2001	<b>020-222</b>
	Velocity Stack 45mm	35-39mm	1130-802-2001	<b>020-244</b>
3.	Clamps	26-33mm	1129-803-7000	<b>018-798</b>
		35-39mm	1129-804-7000	<b>018-799</b>
4.	Mounting Adapters (Spigots)			<b>Pg.126-127</b>
5.	O-Ring	26-33mm	<b>0901-812-6000</b>	<b>018-600</b>
		35-39mm	<b>0901-012-6000</b>	<b>018-601</b>
6.	Tension Spring	26-39mm	1291-804-2000	<b>018-604</b>
7.	Tube	26-39mm	0840-846-0000	<b>018-606</b>
8.	Collar	26-39mm	1118-878-2000	<b>018-608</b>
9.	Screw	26-39mm	4139-802-1100	<b>018-610</b>
10.	Top Cap	26-39mm	1030-814-2002	<b>018-612</b>
11.	Gasket, Top Cap	26-39mm	<b>1031-802-2002</b>	<b>018-614</b>
12.	Jet Needle (see page 53 for * optional Jet Needles)			
	5 Clip position	26-33mm	N427-11Y-xxx	<b>Pg.131</b>
	7 Clip position	26-33mm	N427-12Y-xxx	<b>Pg.131</b>
	5 Clip position	35-39mm	N427-38-xxx	<b>Pg.131</b>
	7 Clip position	35-39mm	N427-51-xxx	<b>Pg.131</b>
13.	Clip	26-39mm	0403-802-1000	<b>018-616</b>
14.	Locknut	26-39mm	0208-803-1200	<b>018-618</b>
15.	Stop Screw	26-39mm	1034-814-2000	<b>018-620</b>
16.	Screw	26-39mm	W9155-04060	<b>018-622</b>
17.	Valve Plate	26-33mm	1019-802-2101	<b>018-624</b>
		35-39mm	1019-801-2101	<b>018-625</b>
18.	Clip	26-39mm	W9302-3000	<b>018-626</b>
			16179-676-3000	
19.	Plain Washer	26-39mm	0301-825-7000	<b>018-628</b>
20.	Link Arm	26-39mm	1061-805-2000	<b>018-630</b>
21.	Spring	26-39mm	1291-802-2000	<b>018-632</b>
22.	Throttle Valve	26-33mm	N502-04x-00	<b>Pg.129</b>
		35-39mm	N502-03x-00	<b>Pg.129</b>
23.	Float Bowl	26-39mm	1050-825-2000	<b>018-660</b>
24.	Drain Bolt	26-39mm	1018-801-2000	<b>018-662</b>
25.	O-Ring	26-39mm	<b>16173-001-0040</b>	<b>018-664</b>
26.	Starter Jet	26-39mm	1001-108-xxx	<b>Pg.149</b>
27.	O-Ring	26-39mm	<b>0901-811-6000</b>	<b>018-668</b>
28.	Arm Pin	26-39mm	<b>W9525-25250</b>	<b>018-670</b>
29.	Float	26-39mm	1052-818-2100	<b>018-672</b>
30.	Clip	26-39mm	<b>0405-019-1000</b>	<b>018-674</b>
31.	Needle Valve	26-39mm	<b>16155-ZG8-L100</b>	<b>018-676</b>
32.	Screw	26-39mm	W9155-04060	<b>018-622</b>
33.	Plate	26-39mm	1164-038-2000	<b>018-678</b>
34.	Valve Seat (Std)	26-39mm	<b>N360-01L00-3.2</b>	<b>018-690</b>
	Valve Seat (*Optional)	26-39mm	N360-01x00	<b>Pg.128</b>
35.	O-Ring, Valve Seat	26-39mm	<b>16075-MB0-0030</b>	<b>018-694</b>
36.	Main Air Jet	26-39mm	N424-14-xxx	<b>Pg.151</b>
37.	Slow Jet	26-39mm	N424-24-xxx	<b>Pg.148</b>
38.	Main Jet	26-39mm	99101-357-xxx	<b>Pg.150</b>
39.	Nozzle Holder	26-39mm	N426-04000	<b>018-696</b>
40.	Screw	26-39mm	4115-800-1101	<b>018-698</b>
41.	Jet Block	26-39mm	1605-xxx-2001	<b>Pg.130</b>
42.	Gasket	26-33mm	1202-809-2002	<b>018-710</b>
		35-39mm	1202-808-2002	<b>018-712</b>
43.	Nozzle, Flat Type	26-39mm	1041-800-2000	<b>018-714</b>
	Nozzle, Screen Type	26-39mm	1041-801-2000	<b>018-715</b>
	Nozzle Screen Type-Used for drag racing and alcohol conversions.			
44.	Air Screw	26-39mm	1014-004-2002	<b>018-718</b>
45.	Spring	26-39mm	1290-003-2001	<b>018-720</b>
46.	O-Ring	26-39mm	<b>0901-006-6000</b>	<b>018-722</b>
47.	Screw	26-39mm	4110-806-1100	<b>018-724</b>
48.	Nut	26-39mm	0205-800-1100	<b>018-726</b>
49.	Bolt	26-39mm	0118-801-1100	<b>018-728</b>

No.	Description	Application	Keihin No.	Order No.
50.	Plain Washer	26-39mm	0301-009-1100	<b>018-730</b>
51.	Wave Washer	26-39mm	2007-800-2000	<b>018-732</b>
52.	Plain Washer	26-39mm	0301-104-7000	<b>018-734</b>
53.	Clip	26-39mm	W9302-25000	<b>018-736</b>
54.	Collar	26-39mm	1118-801-2000	<b>018-738</b>
55.	Shaft	26-39mm	1111-813-2000	<b>018-740</b>
56.	Lever	26-39mm	1113-861-2001	<b>018-742</b>
57.	Lever	26-39mm	1113-862-2000	<b>018-744</b>
58.	Screw	26-39mm	4139-804-1100	<b>018-746</b>
59.	Bracket, Top/Bottom	26-39mm	1190-833-2000	<b>018-748</b>
60.	T-Joint	26-39mm	1077-804-7000	<b>018-751</b>
61.	T-Joint	26-39mm	1077-803-7000	<b>018-753</b>
			Single Outlet	<b>021-853</b>
62.	O-Ring	26-39mm	<b>W9351-13057</b>	<b>018-755</b>
63.	Screw	26-39mm	W9155-04060	<b>018-622</b>
64.	Bracket	26-39mm	1190-832-2000	<b>018-757</b>
65.	Rubber Cap	26-39mm	<b>1028-808-7000</b>	<b>018-759</b>
66.	Clip	26-39mm	<b>W9535-55000</b>	<b>018-761</b>
67.	Link Lever	26-39mm	1100-836-2100	<b>018-763</b>
68.	Collar	26-39mm	1118-861-7000	<b>018-765</b>
69.	Collar	26-39mm	1118-860-7000	<b>018-767</b>
70.	Spring	26-39mm	1305-883-2000	<b>018-769</b>
71.	Throttle Shaft 4-cyl.	26-39mm	5025-847-2200	<b>018-771</b>
72.	Screw	26-39mm	4139-803-1100	<b>018-773</b>
73.	Bracket	26-39mm	1190-831-2002	<b>018-775</b>
74.	Idle Speed Screw	26-39mm	1034-808-2000	<b>018-777</b>
	(Stop Screw)			
74A.	Idle Speed Screw*	26-39mm	1034-902-2100	<b>018-778</b>
	(Stop Screw) *Option			
75.	Spring	26-39mm	1290-849-2003	<b>018-779</b>
76.	Plain Washer	26-39mm	16178-ML7-0040	<b>018-781</b>
			W9201-05100 (old number)	
77.	Nut	26-39mm	94001-0508-0S	<b>018-783</b>
78.	Screw	26-39mm	93500-05025-1H	<b>018-785</b>
79.	Rubber Cap	26-39mm	1028-042-7001	<b>018-787</b>
80.	Cap	26-39mm	1029-805-7000	<b>018-789</b>
81.	Spring	26-39mm	1300-136-2000	<b>018-791</b>
82.	Starter Valve	26-39mm	1166-802-2101	<b>018-793</b>
83.		26-39mm	1099-805-7000	<b>018-795</b>
84.	L-Joint	26-39mm	1074-817-7001	<b>018-797</b>
85.	Air Leak Jet	26-39mm	1001-108-xxx	<b>Pg.149</b>
86.	End Cap	26-39mm	1096-810-2000	<b>018-796</b>

See page 128 for CR Special Carburetor Kits and Methanol Conversion Kits.



# KEIHIN CR Special Mounting Adapters (Spigots)

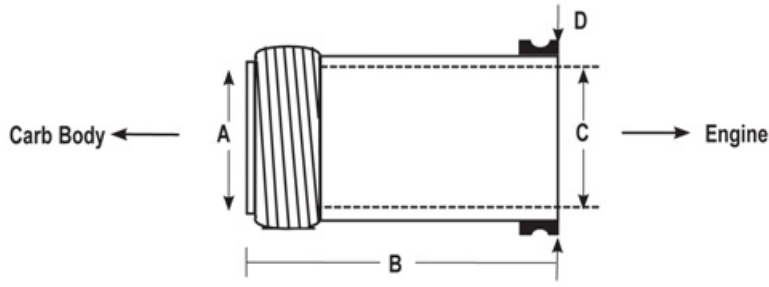

See Page 127 for Dimensions

## Keihin CR Special Mounting Adapters (Spigots) Sold each.

### Honda

Application	26mm	29mm	31mm	33mm	35mm	37mm	39mm
CB650 82-on	---	020-023	020-013	---	---	---	---
CB700SC	---	020-023	020-013	---	---	---	---
CB750SOHC	---	020-473	020-474	---	---	---	---
CB750DOHC	Special Adapter for Racing Use	---	020-044	020-049	020-060	---	---
CB900DOHC	---	020-032	020-044	020-049	020-060	020-069	020-080
CB1100	---	---	---	020-049	020-060	020-069	020-080

### Kawasaki

GPz550 82	020-040	---	---	---	---	---	---
ZX600R Ninja	---	---	020-025	020-026	---	---	---
ZX900 Ninja	---	---	---	020-051	020-076	---	---
ZX1000R	---	---	---	020-050	020-076	020-069	---
KZ750 Z11	---	020-012	---	020-042	---	---	---
KZ750 FXII/III	---	020-010	020-031	---	020-065	---	---
KZ900 Z1	---	020-012	020-025	020-042	020-028	---	---
KZ1000	---	---	020-025	020-026	020-028	020-069	020-080
GPz1100	---	---	---	020-051	020-066	020-069	020-080
GPX750	---	---	---	020-052	020-059	---	---

### Suzuki

GS750	---	020-024	020-025	020-026	---	---	---
GS850	---	020-024	020-025	020-026	020-028	---	---
GS1000	---	---	020-025	020-026	020-028	---	---
GSX1000	---	020-023	020-013	---	---	---	---
GSX-R750	---	---	---	020-051	020-066	020-069	---
GSX-R1100	---	---	---	---	020-092	020-069	020-080
GS1100	---	---	---	020-051	020-076	020-069	020-080
GS1150	---	---	---	020-051	020-059	020-069	020-080

### Yamaha

XS750	---	---	020-034	---	---	---	---
XJ1100/ XS1100	---	---	---	020-051	020-076	---	---
FJ1100/FJ1200	---	---	---	020-051	020-076	---	---
FZ600	---	020-024	020-025	(use FJ600 Rubber Flange)	---	---	---

### Dual CR Adapters

Kaw EX250R	---	---	020-099	020-098	---	---	---
Kaw EX500	---	---	---	020-050	020-083	020-081	020-091
Yam SRX600	---	---	020-099	020-098	020-097	020-088	---
Triumph Bonneville	---	---	---	---	020-072	---	---

# KEIHIN CR Special Mounting Adapters (Spigots)

The CR Special mounting adapter spigots are made in Japan by Keihin especially for the CR Special carburetor for custom designs. Sold each.

Application	ID Mark	I.D. Carb Side "A"	Length "B"	I.D. Engine "C"	O.D. Engine "D"	Order No.
CR26	N195-07A00	26mm	28mm	26mm	30mm	020-064
CR26	1253-832-2000	26mm	40mm	26mm	35mm	020-039
CR26	1253-834-2000	26mm	56mm	30mm	36mm	020-040
CR29	1253-801-2000	29mm	46mm	34.2mm	40mm	020-010
CR29	1253-802-2001	29mm	45mm	34.4mm	44mm	020-011
CR29	1253-803-2001	29mm	42mm	29mm	34mm	020-012
CR29	1253-815-2000	29mm	34.5mm	34.5mm	40mm	020-023
CR29	1253-816-2000	29mm	42mm	34.5mm	40mm	020-024
CR29	1253-824-2000	29mm	40mm	36.5mm	44mm	020-032
CR29	1253-835-2000	29mm	29mm	29mm	34mm	020-041
CR29	N195-05A00	29mm	38mm	30mm	40mm	020-062
CR29	N195-06A00	29mm	46mm	32.5mm	40mm	020-063
CR29	N195-10F00	29mm	28mm	29mm	37mm	020-473
CR31	1253-804-2000	31mm	34.5mm	34.5mm	40mm	020-013
CR31	1253-817-2000	31mm	42mm	34.5mm	40mm	020-025
CR31	1253-823-2000	31mm	46mm	34.2mm	40mm	020-031
CR31	1253-825-2000	31mm	40mm	34.5mm	40mm	020-033
CR31	1253-826-2000	31mm	46mm	32.5mm	38mm	020-034
CR31	1253-829-2000	31mm	55mm	34.5mm	40mm	020-035
CR31	1253-840-2000	31mm	50mm	34.2mm	44mm	020-044
CR31	1253-842-2001	31mm	46mm	34.2mm	42mm	020-046
CR31	N195-10D00	31mm	25mm	31mm	38mm	020-099
CR31	N195-10G00	31mm	28mm	31mm	37mm	020-474
CR33	N195-06B00	33mm	46mm	32.5mm	40mm	020-074
CR33	1253-818-2000	33mm	42mm	34.5mm	40mm	020-026
CR33	1253-836-2000	33mm	29mm	29mm	34mm	020-042
CR33	1253-837-2000	33mm	45mm	34.5mm	44mm	020-043
CR33	1253-841-2001	33mm	46mm	34.2mm	42mm	020-045
CR33	1253-845-2000	33mm	50mm	36.4mm	44mm	020-049
CR33	1253-847-2000	33mm	33mm	36mm	42mm	020-050
CR33	1253-848-2000	33mm	46mm	36mm	42mm	020-051
CR33	1253-849-2000	33mm	40mm	36mm	42mm	020-052
CR33	N195-10C00	33mm	25mm	33mm	38mm	020-098
CR35	1253-820-2000	35mm	42mm	34.5mm	40mm	020-028
CR35	1253-813-2000	35mm	34.5mm	34.5mm	40mm	020-021
CR35	N195-01A00	35mm	46mm	34.2mm	42mm	020-059
CR35	N195-03A00	35mm	50mm	36.4mm	44mm	020-060
CR35	N195-08A00	35mm	46mm	34mm	42mm	020-065
CR35	N195-09A00	35mm	46mm	34.5mm	42mm	020-066
CR35	N195-08B00	35mm	46mm	36mm	42mm	020-076
CR35	N195-02A00	35mm	33mm	38mm	44mm	020-083
CR35	N195-02B00	35mm	31mm	38mm	44mm	020-084
CR35	N195-03E00	35mm	46mm	36.4mm	44mm	020-092
CR35	N195-09C00	35mm	25mm	33mm	38mm	020-097
CR35	N195-03K00	35mm	25mm	36mm	42mm	020-072
CR37	N195-01B00	37mm	46mm	38mm	44mm	020-069
CR37	N195-02C00	37mm	33mm	38mm	44mm	020-081
CR37	N195-03C00	37mm	31mm	35mm	44mm	020-082
CR37	N195-03D00	37mm	41mm	38mm	43mm	020-087
CR37	N195-858-2000	37mm	25mm	33mm	38mm	020-088
CR39	N195-01C00	39mm	46mm	38mm	44mm	020-080
CR39	N195-02E00	39mm	33mm	38mm	44mm	020-091
CR39	N195-02F00	39mm	31mm	38mm	44mm	020-095
CR39	N195-12B00	39mm	31mm	39mm	48mm	020-096
CR39	N195-03J00	39mm	40mm	36.4mm	44mm	020-093

VINTAGE  
INTAKE  
ENGINE  
SUSPENSION  
CONTROL  
ELECTRICAL  
CHEMICAL  
TOOLS  
WATERCRAFT



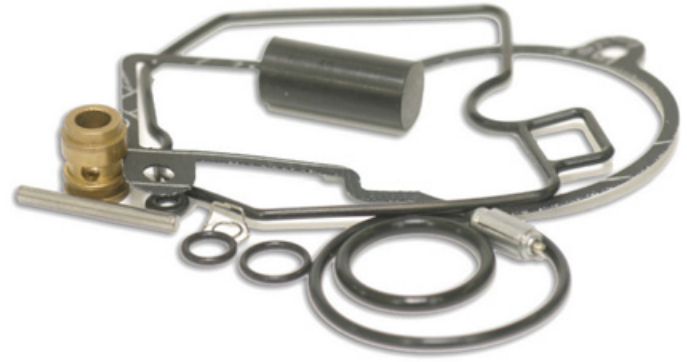

## Sudco Methanol Conversion Kit

The Methanol Kit from Sudco includes all the necessary components: main jets, needles, needle valves, etc. All the jetting required to convert your Keihin CR Special carburetor to methanol usage. Sold as a kit. **Note: Requires experienced tuner or technician familiar with rejetting for methanol usage.**

Application	Order No.
CR Special 26-33mm	<b>018-855</b>
CR Special 35-39mm	<b>018-856</b>

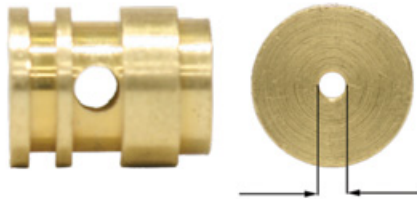

## CR Special Needle Valve Seats

Valve Seat diameter should be determined according to maximum fuel flow and fuel pressure. Valve Seat only, Sold each.

Size	Keihin No.	Order No.
1.6mm	N360-01D00	<b>018-682</b>
1.8mm	N360-01E00	<b>018-683</b>
2.0mm	N360-01F00	<b>018-684</b>
2.2mm	N360-01G00	<b>018-685</b>
2.4mm	N360-01H00	<b>018-686</b>
2.6mm	N360-01I00	<b>018-687</b>
2.8mm	N360-01J00	<b>018-688</b>
3.0mm	N360-01K00	<b>018-689</b>
3.2mm	N360-01L00	<b>018-690</b>
O-Ring for Needle Valve seats listed	16075-MB0-0030	<b>018-694</b>
Needle Valve for Valve Seats listed	16155-ZG8-L100	<b>018-676</b>
Clip for Needle Valve	<b>018-676</b> 0405-019-1000	<b>018-674</b>

## Sudco CR Special Carburetor Rebuild Kits

Sudco rebuild kits for CR special's contain GENUINE Keihin replacement parts, everything necessary to perform routine carburetor service. Kits are sold per set for 4 carbs. Two kits available;

Description	Order No.
CR Special 26-33mm Rebuild Kit.	<b>018-851</b>
CR Special 35-39mm Rebuild Kit.	<b>018-852</b>

**Note:** Kits come with 3.2 Needle Seat size. 2.4 Needle Seat size is available as an option. Please specify needle seat size when ordering carb rebuild kit.

### Exploded (Page 37)

View No.	Qt	Contents
5.	4	ADP O-Ring
11.	4	Gasket
25.	4	O-Ring
27.	4	O-Ring
28.	4	Arm Pin
30.	4	Clip
31.	4	Needle Valve
34.	4	Needle Valve Seat 3.2
35.	4	O-Ring
46.	4	O-Ring
62.	12	O-Ring
65.	2	Rubber Cap
66.	2	Inlet Cap Clip
<b>34.</b>	<b>4</b>	<b>Needle Valve Seat 2.4* is available as an option. Please specify when ordering.</b>





## Keihin CR Special Velocity Stacks

The Keihin Velocity Stacks are the most efficient and are a perfect fit for the CR Special Smoothbores. These stacks are available in selected sizes shown. No tools are necessary for installation. Sold each. **Clamps sold separate.**

Length	Color	Carb Size	Keihin No.	Order No.
45mm Straight	Black	26-33mm	1130-800-2001	<b>020-220</b>
70mm Straight	Black	26-33mm	1130-801-2001	<b>020-222</b>
45mm Straight	Black	35-39mm	1130-802-2001	<b>020-244</b>
Clamp	Gray	26-33	1129-803-7000	<b>018-798</b>
Clamp	Gray	35-39	1129-803-7000	<b>018-799</b>



## Throttle Valves

To enrich the throttle valve, use a smaller number (cutaway). Recommended increment change is .5mm. Sold each.

Description	Keihin No.	Order No.
2.0 slide for CR26-33mm	N502-04A	<b>018-640</b>
2.5 slide for CR26-33mm	N502-04B	<b>018-641</b>
3.0 slide for CR26-33mm	N502-04C	<b>018-642</b>
3.5 slide for CR26-33mm	N502-04D	<b>018-643</b>
4.0 slide for CR26-33mm	N502-04E	<b>018-644</b>
2.0 slide for CR35-39mm	N502-03A	<b>018-650</b>
2.5 slide for CR35-39mm	N502-03B	<b>018-651</b>
3.0 slide for CR35-39mm	N502-03C	<b>018-652</b>
3.5 slide for CR35-39mm	N502-03D	<b>018-653</b>
4.0 slide for CR35-39mm	N502-03E	<b>018-654</b>



## Keihin CR K&N Air Filters

K&N Air Filters for Keihin CR Specials. Sold each.

Description	Size	Order No.
RC-1820 with Chrome End Cap	26-33mm	<b>005-140</b>
RC-0981 with Chrome End Cap	35-39mm	<b>005-121</b>
RU-0981 with Rubber End Cap	35-39mm	<b>005-744</b>



## Idle Speed Screw (Stop Screw) (No. 74A Exploded View)

Optional longer length Idle Speed Screw for Keihin CR Special carburetors. Sold Each. See page 37 exploded view and page 38 replacement parts, **No. 74A.**

Description	Keihin No.	Order No.
Idle Speed Screw (Stop Screw)	1034-902-2100	<b>018-778</b>



Photo courtesy of Bonneville Performance  
#35 Kyle Ragsdale



## Jet Blocks

Sold each.

Size	Keihin No.	Order No.
CR26mm	1605-806-2001	<b>018-701</b>
CR29mm	1605-809-2000	<b>018-702</b>
CR31mm	1605-811-2000	<b>018-703</b>
CR33mm	1605-813-2000	<b>018-704</b>
CR35mm	1605-801-2001	<b>018-705</b>
CR37mm	1605-803-2000	_____
CR39mm	1605-805-2000	<b>018-707</b>

## Nozzle & Nozzle Holder

Sold each.  
There are two primary type nozzles, Flat and Screen type. The combination of nozzle and nozzle holder controls full throttle fuel delivery characteristics. The Flat Nozzle is stock. Screen type nozzle flows more fuel at high RPM's and is used for drag racing and alcohol conversions.

Description	Keihin No.	Order No.
Nozzle Holder	N426-04000	<b>018-696</b>
Flat Nozzle	1041-800-2000	<b>018-714</b>
Screen Nozzle	1041-801-2000	<b>018-715</b>

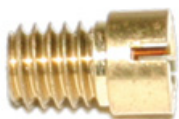
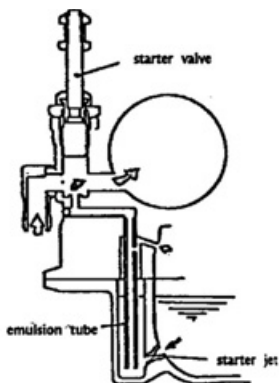

## CR Special Starter Jets (1001-108-XXX)

The starter jet adjusts the richness of the starter valve by metering the amount of fuel entering from float bowl.

**Applications:** CR Special (CRS) 26 - 33mm, 35 - 39mm Carburetors.

Size	Order No.	Size	Order No.
#35	<b>019-370</b>	#60	<b>019-375</b>
#40	<b>019-371</b>	#65	<b>019-376</b>
#45	<b>019-372</b>	#70	<b>019-377</b>
#50	<b>019-373</b>		

## Main Air Jet N424-14-XXX

The Main Air Jet meters the air entering the needle jet holder. Use smaller number to richen.

**Applications:** CR Special (CRS) 26 - 33mm & 35 - 39mm Carburetors

Size	Order No.	Size	Order No.	Size	Order No.
#80	<b>019-301</b>	#140	<b>019-309</b>	#200	<b>019-315</b>
#90	<b>019-303</b>	#150	<b>019-310</b>	#210	<b>019-316</b>
#95	<b>019-304</b>	#160	<b>019-311</b>	#220	<b>019-317</b>
#100	<b>019-305</b>	#170	<b>019-312</b>	#230	<b>019-318</b>
#110	<b>019-306</b>	#180	<b>019-313</b>	#240	<b>019-319</b>
#120	<b>019-307</b>	#190	<b>019-314</b>	#250	<b>019-320</b>
#130	<b>019-308</b>				



## 5 Clip Positions

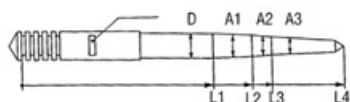

### CR26-33mm (5-Clip Position) Sold each.

Size	Keihin No.		Order No.
Y50	N427-11Y50	Richer ↑ ↓ Leaner	017-130
Y60	N427-11Y60		017-131
Y70	N427-11Y70		017-132
Y80	N427-11Y80		017-133
Y90	N427-11Y90		017-134
Y00	N427-11Y00		017-135
Y01	N427-11Y01		017-136
Y02	N427-11Y02	017-137	
Y03	N427-11Y03	Leaner	017-138

#### Clip for Jet Needle

0403-802-1000 **018-616**

## 7 Clip Positions

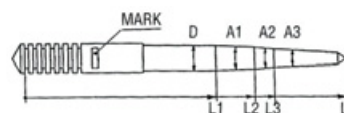

### CR26-33mm (7-Clip Position) Sold each.

Size	Keihin No.		Order No.
YY5	N427-12Y50	Richer ↑ ↓ Leaner	017-074
YY6	N427-12Y60		017-075
YY7	N427-12Y70		017-076
YY8	N427-12Y80		017-077
YY9	N427-12Y90		017-078
YY0	N427-12Y00		017-079
YY1	N427-12Y10		017-080
YY2	N427-12Y20	017-081	
YY3	N427-12Y30	Leaner	017-082

#### Clip for Jet Needle

0403-802-1000 **018-616**

## 5 Clip Positions

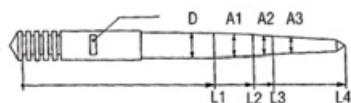

### CR35-39mm (5-Clip Position) Sold each.

Size	Keihin No.		Order No.
3865	N427-38A00	Richer ↑ ↓ Leaner	—
3867	N427-38B00		—
3869	N427-38C00		017-152

#### Clip for Jet Needle

0403-802-1000 **018-616**

## 7 Clip Positions

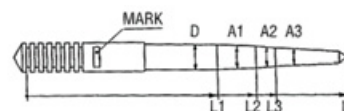

### CR35-39mm (7-Clip Position) Sold each.

Size	Keihin No.		Order No.	
5173	N427-51A00	Richer ↑ ↓ Leaner	017-100	
5174	N427-51B00		017-101	
5175	N427-51C00		017-102	
5176	N427-51D00		017-103	
5177	N427-51E00		017-104	
5178	N427-51F00		017-105	
5179	N427-51G00		017-106	
5180	N427-51H00		017-107	
5181	N427-51J00		017-108	
5182	N427-51K00		017-109	
5183	N427-51L00		Leaner	017-110

#### Clip for Jet Needle

0403-802-1000 **018-616**



## Sudco Carburetor Needle Shims

Sold 12 piece package.

Description	Dimensions - Inside, Outside, Thickness	Order No.
Most Keihin	3.2mm I.D. x 7mm O.D. x .020" (0.5mm) thick	009-396
Most Mikuni	2.7mm I.D. x 6.35mm O.D. x .020" (0.5mm) thick	009-395

# KEIHIN PWK Carburetors



Non Air Striker PWK33, 35, 36, 38, 39, 41



PWK36 Quad Vent



PWK 35, 38 Air Striker/Quad Vent

## Keihin PWK Series Carburetors

Producing power without compromise, Keihin PWK carburetors have set the standard for ATV, motocross, and offroad racing carburetors. Because of their great performance, they come stock on a lot of leading brand names. PWK features include:

- Chromed semi-flat (D shape) throttle valve for excellent response and more flow at high RPM.
- Throttle Bores sized to give maximum power.
- Quad Vents - Eliminates post jump bogging from fuel plugged vent passages.
- PWK Air Strikers - Directs air to main nozzle for improved signal and throttle response.

PWK carburetors are available in Standard (Non Air Striker) and Air Striker/Quad Vent. Sold each.

## PWK (Non Air Striker) Standard Jetting Specifications

Carburetor	Main Jet	Slow Jet	Jet Needle	Throttle Valve Cutaway	Float Height	Description/Mark	Order No.
PWK28	#135	#38	46-JJH	3.5	19mm	PWK28/29S	016-144
PWK33	#165	#52	48-CGL	6.0	16mm	PWK33/S46	016-148
PWK35	#160	#68	48-DGK	6.0	16mm	PWK35/70R	016-150
PWK38	#172	#58	48-DEG	6.0	16mm	PWK38/71R	016-153
PWK39	#160	#60	48-DGH	6.0	16mm	PWK39/72R	016-155
PWK41 Pro-Series	#160	#60	48-DGH	6.0	16mm	PWK41 Pro-Series	016-156

## PWK Quad Vent/Air Striker Standard Jetting Specifications

PWK35 Quad Vent/Air Striker	#160	#48	48-DEK	4.5	16mm	PWK35 A.S./S65	016-160
PWK36 Quad Vent	#165	#55	48-DGJ	5.0	16mm	PWK36/S63	016-163
PWK38 Quad Vent/Air Striker	#170	#55	48-DDJ	7.0	16mm	PWK38 A.S./S66	016-167

**Note:** \* X00 represents product code stamped on the carburetor body just above the float bowl.

## PWK Special Set Carburetors

Use the following part numbers when ordering for special jetting request. **Please note:** Special Set carburetors are pre-jetted to your request or specific application. Please specify exact jetting details or bike application for each special set carburetor ordered.

Carburetor	Description/Mark	Special Set Order No.
PWK28 Non Air Striker	PWK28/29S	016-189
PWK33 Non Air Striker	PWK33/S46	016-191
PWK35 Non Air Striker	PWK35/70R	016-192
PWK35 Quad Vent/Air Striker	PWK35 A.S./S65	016-197
PWK36 Quad Vent	PWK36/S63	016-198
PWK38 Non Air Striker	PWK38/71R	016-194
PWK38 Quad Vent/Air Striker	PWK38 A.S./S66	016-199
PWK39 Non Air Striker	PWK39/72R	016-195



## Sudco Choke Cable System for all PWK's

Includes parts A thru F. listed below. All PWK carburetors.  
Order No. 018-501

A.	Cable Sealing Cap	16118-166-0040	018-002
B.	Choke Plunger	W1275-028-9901	021-512
C.	Choke O-Ring	0901-069-6000	021-527
D.	Spring	1290-922-2000	021-582
E.	Cable Holder	W1551-140-9900	021-583



## PWK OEM Float Bowl O-Ring

Genuine replacements for applications listed.  
**Made in Japan.** Sold each.

### Honda

Model	Year	Carb	OEM Reference	Order No.
CR80/CR80RB	96-01	PWK28	16163-KBA-850	<b>018-406</b>
CR85R/RB	02-07	PWK28	16163-KBA-850	<b>018-406</b>
CR125R	98-00	PWK38	16163-KZ4-J01	<b>021-872</b>

### Kawasaki

KX85A	01-13	PWK28	92055-1389	<b>018-406</b>
KX100D	01-13	PWK28	92055-1389	<b>018-406</b>
KX125	88-91	PWK35	11009-1716	<b>018-113</b>
KX125	92-95	PWK36	11009-1716	<b>018-113</b>
KX125	96-97	PWK35	11009-1716	<b>018-113</b>
KX125	98-00	PWK36	11060-1254	<b>021-872</b>
KDX200	88-06	PWK35	11009-1716	<b>018-113</b>
KDX220	97-05	PWK33	11009-1716	<b>018-113</b>
KX250	88-97	PWK33	11009-1716	<b>018-113</b>
KX250	98-07	PWK38	11060-1254	<b>021-872</b>
KX500	88-04	PWK38	11009-1716	<b>018-113</b>

### KTM

Models with standard PWK Carb	54531610000	<b>018-113</b>
Non Air Striker, no hole on o-ring		
Models with PWK AG Carb	54831010000	<b>021-872</b>
Quad Vent/Air Striker with hole on o-ring		

### Suzuki

RM85	02-13	PWK28	13251-03B00	<b>018-406</b>
RM100K3	2003	PWK28	K9205-51389	<b>018-406</b>
RM250V	1997	PWK38	13696-28E00	<b>018-113</b>
RM250W/X/Y/K1-K7	98-07	PWK38	13696-44E00	<b>021-872</b>

### Yamaha

YZ85	93-13	PWK28	5PA-14984-00-00	<b>018-406</b>
YZ250	95-98	PWK38	4MX-14984-00-00	<b>018-113</b>
YZ250	99-13	PWK38	4JT-14984-00-00	<b>021-872</b>



## Tokyomods Drain Plug

Keeps all fuel contaminants including water away from the main jet, helps control fuel slosh and bogging, won't get distorted from over tightening, and easy to reach for quicker jetting changes. Machined from 6061 aluminum. Also fits Keihin FCR-MX, PJ, PWK, PWM, and PE carbs.

Application	Color	Order No.
	Red	<b>024-230R</b>
FCR-MX, PJ, PWK,	Blue	<b>024-230B</b>
PWM, PE	Black	<b>024-230K</b>
	Mag	<b>024-230M</b>

## GENUINE Keihin Dealer Jet Kit (Main & Slow)

Genuine OEM **99101-357** main jets and **N424-21** slow jets.  
**Made in Japan.**

**Keihin Dealer Jet Kit, sizes** Order No. **019-999**

**#120 - #180 Main Jets and sizes #40 - #65 Pilot Jets**

Kit includes qt 2 of the following jet sizes:

Main Jets: #120, #122, #125, #128, #130, #132, #135, #150, #152, #155, #158, #160, #162, #165, #168, #170, #172, #175, #178, #180.

Slow Jets: #40, #42, #45, #48, #50, #52, #55, #58, #60, #62, #65.

Total jets: 62 with storage box.

### Applications

**Honda** CRF250R (04-08), CRF250X (04-09), CRF450R (02-08), CRF450X (05-09), CRF450X (2012)

**Kawasaki** KX250, KX250F (04-10), KX450 (06-08)

### KTM

**Suzuki** RM250, RM-Z250K (04-10), RM-Z450K, (05-07)

**Yamaha** YZ250, WR250F (01-08), YZ250F (01-08)

YZ426F (00-02), WR426F (01-02)

YZ450F (03-08), WR450 (03-08), YFZ450 (04-08)

### 99101-357 Hex Main Jets

Sold each.

Size	Order No.
#120	<b>019-117</b>
#122	<b>019-118</b>
#125	<b>019-119</b>
#128	<b>019-120</b>
#130	<b>019-121</b>
#132	<b>019-122</b>
#135	<b>019-123</b>
#150	<b>019-129</b>
#152	<b>019-130</b>
#155	<b>019-131</b>
#158	<b>019-132</b>
#160	<b>019-133</b>
#162	<b>019-150</b>
#165	<b>019-134</b>
#168	<b>019-151</b>
#170	<b>019-135</b>
#172	<b>019-152</b>
#175	<b>019-136</b>
#178	<b>019-153</b>
#180	<b>019-137</b>

For more sizes see page 150

### N424-21 Slow Jets

Sold each.

Size	Order No.
#40	<b>019-007</b>
#42	<b>019-008</b>
#45	<b>019-009</b>
#48	<b>019-010</b>
#50	<b>019-011</b>
#52	<b>019-012</b>
#55	<b>019-013</b>
#58	<b>019-014</b>
#60	<b>019-015</b>
#62	<b>019-016</b>
#65	<b>019-017</b>

For more sizes see page 148

# KEIHIN PWK 28 Exploded View

## PWK28 Replacement Parts

Keihin Part No. Highlighted in **BOLD RED** are included in rebuild kit.

No.	Description	Keihin No.	Order No.
2A.	Starter Valve (pull knob) Complete	1166-818-2100	018-500
2B.	Choke Cable System Complete		018-501
*See individual parts with asterisk *50, *51, *52, *53, *54			
3.	Float	W1310-080-9901	018-397
4.	Float Bowl Complete	N350-03A00	018-575
5.	Gasket, Float Bowl	<b>W1354-042-9900</b>	018-406
6.	Plug Screw	16162-ND4-7511-M1	018-128
7.	O-Ring, Plug Screw	<b>16173-001-0040</b>	018-664
8.	Float Valve Complete	<b>W1362-020-9901</b>	018-389
10.	Slow Jet	N424-21-xxx	Pg.148
11.	Jet Needle	N427-46-xxx	Pg.147
12.	Clip, Jet Needle	<b>16115-169-0040</b>	018-033
13.	Throttle Valve	N502-11H00 #3.5	018-582
	Throttle Valve, Chrome (see chart)	N502-52H00 #3.5	018-590
15A.	Top Cover	1030-844-2000	021-575
15B.	Top Cover (option)	1030-843-2200	021-586
16.	Gasket, Top	<b>1202-837-2000</b>	018-566
17.	Air Adjust Screw	<b>W1446-231-9900</b>	018-089
18.	Spring, Air Adjust Screw	<b>W1711-416-9900</b>	018-090
19.	Spring, Throttle Valve	1290-921-2000	018-532
20.	Clip, Float Valve	<b>0405-013-1000</b>	021-576
21.	Screw, Float Bowl	<b>N114-04160</b>	021-577
22.	Bowl, Vent Pipe	W9404-40090	021-578
23.	Overflow Pipe	95003-07042-31	018-534
24.	Float Pin	<b>W9525-25250</b>	018-670
25.	Clip	W9535-35000	018-098
26.	Main Jet (hex type)	99101-357-xxx	Pg.150
26A.	Main Jet SDGAA (round type)	99101-393-xxx	Pg.150
27A.	Cable Adjuster	W9581-59250	018-005
27B.	Cable Adjuster	1036-804-2000	018-542
28.	Nut, Cable Adjuster	W1793-130-9900	018-008
29.	Idle Adjuster	1034-831-2000	018-568
29.	Idle Adjuster (for Chrome T/V)	<b>1034-853-2000</b>	018-569
30.	Spring, Idle Adjuster	1290-923-2000	018-562
30.	Spring, (for Chrome T/V)	<b>1290-963-2000</b>	018-574
31.	Collar, Throttle Spring	1022-805-7000	018-564
32.	Screw, Top Cover	<b>N114-04140</b>	021-580
33.	Washer, Idle Adjuster	0301-078-1200	021-101
34.	Needle Jet	16164-169-0040	018-560
35.	Needle Jet Holder SDGAA	N413-11A00	
35A.	Needle Jet Holder	N413-12A00	021-581
*50.	Starter Valve (Choke Plunger)	W1275-028-9901	021-512
*51.	Spring	1290-922-2000	021-582
*52.	O-Ring,	0901-069-6000	021-527
*53.	Cable Holder	W1551-140-9900	021-583
*54.	Cap	16118-166-0040	018-002

**Note:** If you see "SDGAA" on your carburetor's stamped portion, your main jet and needle jet holder have to be #parts 26A and 35.

**NOTE:** Do not remove parts that are not shown on this extended view.

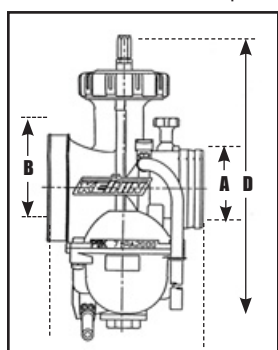

### PWK28 Carburetor Dimensions

Size (mm)	A	B	C	D
PWK28	35	49	83	147.4

### PWK28 Standard Jetting Specifications

Size (mm)	Main Jet	Slow Jet	Jet Needle	Throttle Valve	Float Height	Order No.
PWK28	#135	#38	46 JJH	3.5	19mm	016-144

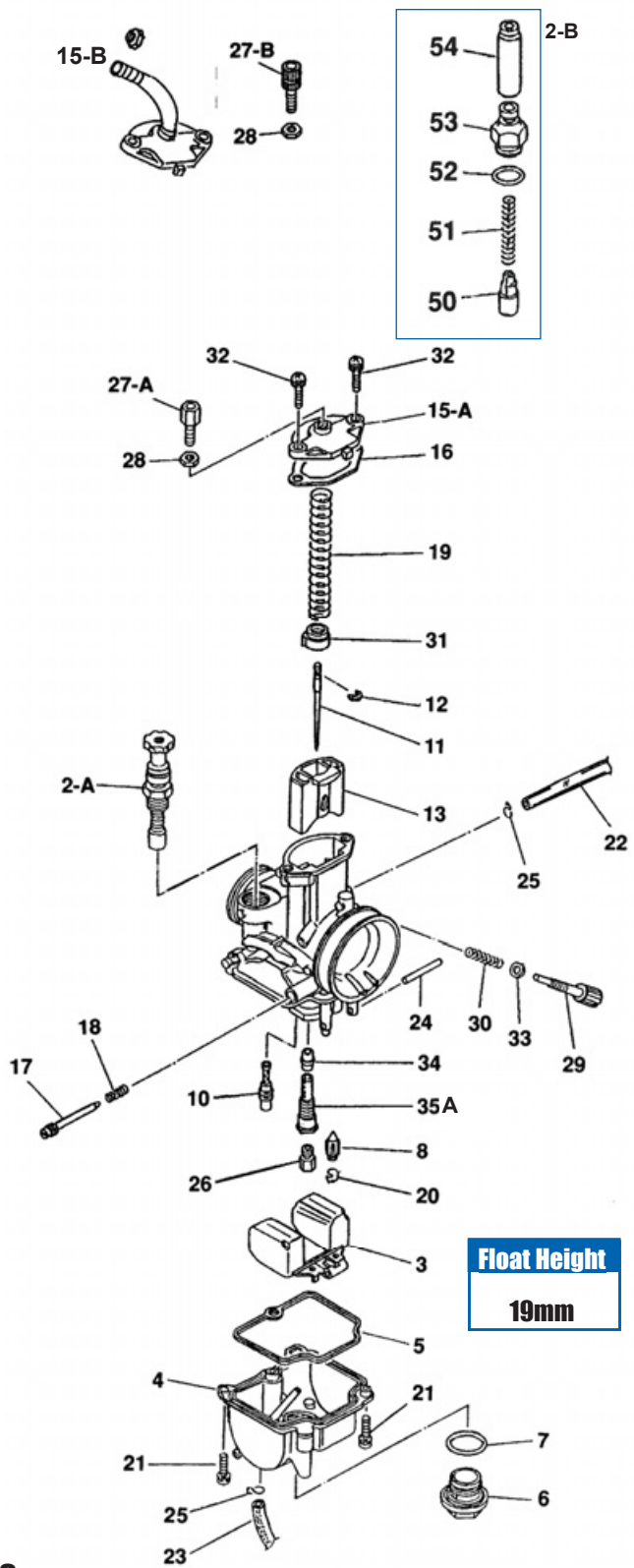



## Sudco PWK 28 Carburetor Rebuild Kit

Sudco rebuild kit for the Keihin PWK28 contains GENUINE Keihin replacement parts. Sold as a kit.

Order No. **020-112**

### Exploded

View No.	Qt	Contents
5.	1	Gasket, Float Bowl
7.	1	O-Ring, Plug Screw
8.	1	Float Valve Complete
12.	1	Clip, Jet Needle
16.	1	Gasket, Top
17.	1	Air Adjust Screw
18.	1	Spring, Air Adjust Screw
20.	1	Clip, Float Valve
21.	2	Screw, Float Bowl
24.	1	Float Pin
29.	1	Idle Adjuster (for Chrome T/V)
30.	1	Spring, (for Chrome T/V)
32.	2	Screw, Top Cover



## Sudco Choke Cable System for all PWK's

Includes parts **A thru E** listed below. All PWK carburetors.

Order No. **018-501**

<b>A.</b>	Cable Sealing Cap	16118-166-0040	<b>018-002</b>
<b>B.</b>	Choke Plunger	W1275-028-9901	<b>021-512</b>
<b>C.</b>	Choke O-Ring	0901-069-6000	<b>021-527</b>
<b>D.</b>	Spring	1290-922-2000	<b>021-582</b>
<b>E.</b>	Cable Holder	W1551-140-9900	<b>021-583</b>



## PWK 28 Throttle Valve Chart

	Cutaway	Keihin No.	Order No.
Rich ↑	1.0	N502-52B00	<b>018-584</b>
	2.0	N502-52C00	<b>018-585</b>
↕	3.0	N502-52D00	<b>018-586</b>
	3.5 (Std)	N502-52H00	<b>018-590</b>
	4.0	N502-52E00	<b>018-587</b>
	5.0	N502-52F00	<b>018-588</b>
Lean ↓	6.0	N502-52G00	<b>018-589</b>



## Tokyomod's Drain Plug

Keeps all fuel contaminants including water away from the main jet, helps control fuel slosh and bogging, won't get distorted from over tightening, and easy to reach for quicker jetting changes. Machined from 6061 aluminum. Also fits Keihin FCR-MX, PJ, PWK, PWM, and PE carbs.

### Application

FCR-MX, PJ, PWK, PWM, PE

### Color

Red	<b>024-230R</b>
Blue	<b>024-230B</b>
Black	<b>024-230K</b>
Mag	<b>024-230M</b>

### Order No.

# KEI HIN PWK 33-41 Exploded View

## Non Air Striker PWK33, 35, 36, 38, 39, 41

## Quad Vent/Air Striker

\*see part numbers 11, 12, 14, 15, 16, 19, 27, 28, 31 from the drawing to the left.

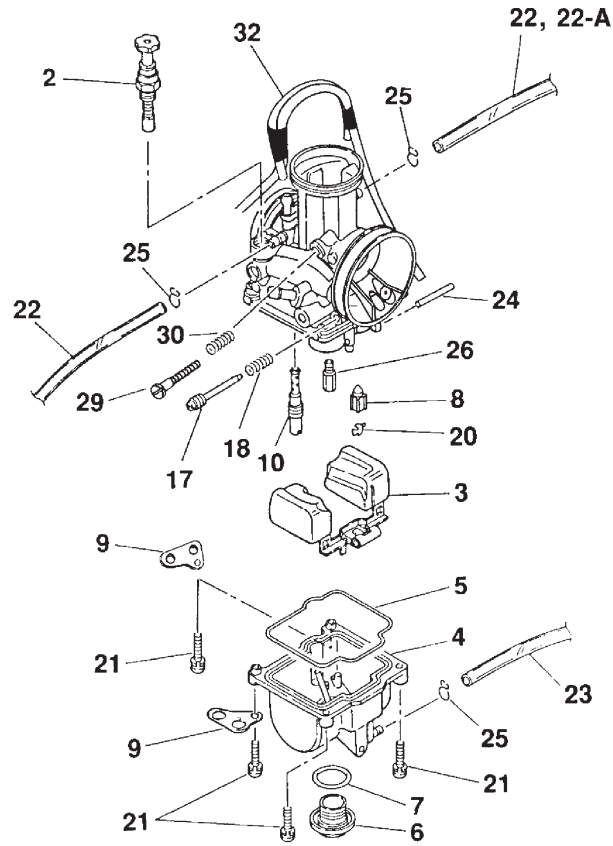
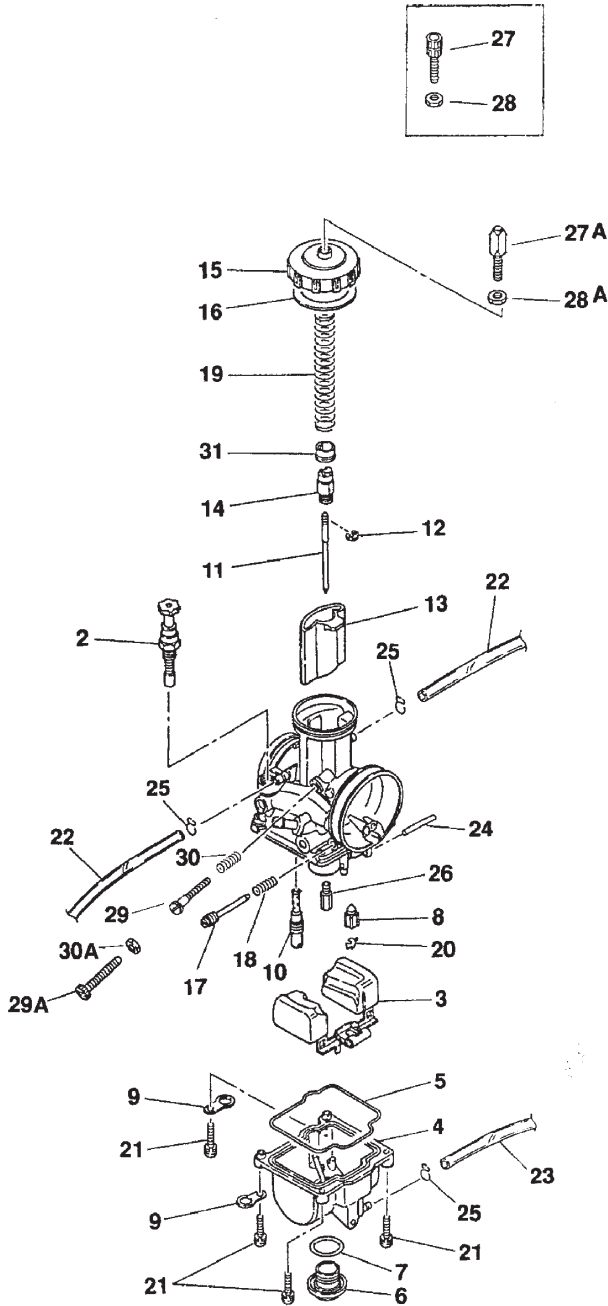

NOTE: Do not remove parts that are not shown on this exploded view.

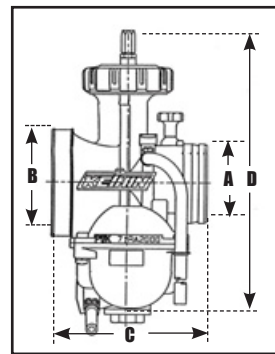

**Float Height**  
**16mm**

NOTE: Do not remove parts that are not shown on this exploded view.

## PWK Standard Jetting Specifications

### Non Air Striker

Size (mm)	Main Jet	Slow Jet	Jet Needle	Throttle Valve	Float Height	Order No.
PWK33/S46	#165	#52	48-CGL	6.0	16mm	016-148
PWK35/70R	#160	#68	48-DGK	6.0	16mm	016-150
PWK38/71R	#172	#58	48-DEG	6.0	16mm	016-153
PWK39/72R	#160	#60	48-DGH	6.0	16mm	016-155
PWK41 Pro-Series	#160	#60	48-DGH	6.0	16mm	016-156

### Quad Vent/Air Striker

PWK35	#160	#48	48-DEK	4.5	16mm	016-160
PWK36 Quad Vent	#165	#55	48-DGJ	5.0	16mm	016-163
PWK38	#170	#55	48-DDJ	7.0	16mm	016-167

Size (mm)	A	B	C	D
PWK33	42	59	91	164.3
PWK35	42	59	91	163.3
PWK36	46	63	91	176.6
PWK38	46	63	91	171.6
PWK39	46	63	91	171.6
PWK41	46	63	91	171.6

## PWK 33-41 Replacement Parts

Keihin Part No. Highlighted in **BOLD RED** are included in rebuild kit.

No.	Description	Application	Keihin No.	Order No.
2A.	Starter Valve (pull knob) Complete	All PWK	1166-818-2100	<b>018-500</b>
2B.	Choke Cable System	All PWK		<b>018-501</b>
3.	Float	All PWK	W1310-079-9921	<b>018-110</b>
4.	Float Bowl Complete	All PWK	W1350-311-9910	<b>018-502</b>
5.	Gasket, Float Bowl	All PWK	<b>16163-ND4-7510-M1</b>	<b>018-113</b>
6.	Plug Screw	All PWK	16162-ND4-7511-M1	<b>018-128</b>
7.	O-Ring, Plug Screw	All PWK	<b>16173-001-0040</b>	<b>018-664</b>
8.	Float Valve Complete	All PWK	<b>1062-814-2100</b>	<b>018-504</b>
9.	Anchor Plate			
	PWK33 Non Air Striker		16179-428-6711-M1	<b>018-119</b>
	PWK35 Non Air Striker		16179-428-6711-M1	<b>018-119</b>
	PWK36 Quad Vent		16179-KZ4-6900	<b>018-505</b>
	PWK38 Non Air Striker		16179-428-6711-M1	<b>018-119</b>
	PWK39 Non Air Striker		16179-428-6711-M1	<b>018-119</b>
	PWK41 Non Air Striker		16179-428-6711-M1	<b>018-119</b>
	PWK35 Quad Vent/Air Striker		16179-KZ4-6900	<b>018-505</b>
	PWK38 Quad Vent/Air Striker		16179-KZ4-6900	<b>018-505</b>
10.	Slow Jet	All PWK	N424-21-xxx	<b>Pg.148</b>
11.	Jet Needle	All PWK	N427-48-xxx	<b>Pg.146</b>
12.	Clip, Jet Needle	All PWK	<b>16155-169-0040</b>	<b>018-033</b>
13.	Throttle Valve		(see chart below)	
14.	Cable Holder	All PWK	1101-804-2000	<b>018-526</b>
15.	Top	All PWK	1030-840-2000	<b>018-528</b>
16.	Gasket	All PWK	<b>W1593-051-9900</b>	<b>018-016</b>
17.	Air Adjust Screw	All PWK	<b>W1446-231-9900</b>	<b>018-089</b>
18.	Spring	All PWK	<b>W1711-416-9900</b>	<b>018-090</b>
19.	Throttle Spring			
	PWK33 Non Air Striker		1290-917-2001	<b>018-530</b>
	PWK35 Non Air Striker		1290-917-2001	<b>018-530</b>
	PWK36 Quad Vent		1290-917-2001	<b>018-530</b>
	PWK38 Non Air Striker		1290-920-2000	<b>018-531</b>
	PWK39 Non Air Striker		1290-920-2000	<b>018-531</b>
	PWK41 Non Air Striker		1290-920-2000	<b>018-531</b>
	PWK35 Quad Vent/Air Striker		1290-917-2001	<b>018-530</b>
	PWK38 Quad Vent/Air Striker		1290-920-2000	<b>018-531</b>
20.	Clip, Float Valve	All PWK	<b>0405-019-1000</b>	<b>018-674</b>
21.	Screw, Float Bowl	All PWK	<b>93892-04016-18</b>	<b>018-122</b>
22.	Bowl Vent Pipe			
	PWK33 Non Air Striker		95003-07042-31	<b>018-534</b>
	PWK35 Non Air Striker		95003-07042-31	<b>018-534</b>
	PWK36 Quad Vent		95003-07042-31	<b>018-534</b>
	PWK38 Non Air Striker		95003-07048-31	<b>018-535</b>
	PWK39 Non Air Striker		95003-07048-31	<b>018-535</b>
	PWK41 Non Air Striker		95003-07048-31	<b>018-535</b>
	PWK35 Quad Vent/Air Striker		95003-07048-31	<b>018-535</b>
	PWK38 Quad Vent/Air Striker		95003-07048-31	<b>018-535</b>

No.	Description	Application	Keihin No.	Order No.
22A.	Bowl Vent Pipe			
	PWK36 Quad Vent		95003-07048-31	<b>018-535</b>
23.	Overflow Pipe	All PWK	95003-05033-31	<b>018-538</b>
24.	Float Pin	All PWK	<b>W9525-25250</b>	<b>018-670</b>
25.	Clip	All PWK	W9535-35000	<b>018-098</b>
26.	Main Jet	All PWK	99101-357-xxx	<b>Pg.150</b>
27.	Cable Adjuster	All PWK	1036-804-2000	<b>018-542</b>
27A.	Cable Adjuster (25mm)	All PWK	W9581-59250	<b>018-005</b>
27B.	Cable Adjuster (20mm)	All PWK	W9581-59200	<b>018-306</b>
28.	Nut, Cable Adjuster	All PWK	0208-007-1100	<b>018-544</b>
28A.	Nut, Cable Adjuster	All PWK	W1793-130-9900	<b>018-008</b>
29.	Idle Adjuster (Plastic)	All	1034-853-2000	<b>018-569</b>
29A.	Idle Adjuster (Brass) For non chrome slides		1034-826-2002	<b>018-546</b>
30.	Spring	All PWK	1290-963-2000	<b>018-574</b>
30A.	Nut (use with 018-546)			
	PWK35 Non Air Striker		94002-05080-0S	<b>018-548</b>
	PWK38 Non Air Striker		94002-05080-0S	<b>018-548</b>
	PWK39 Non Air Striker		94002-05080-0S	<b>018-548</b>
	PWK41 Non Air Striker		94002-05080-0S	<b>018-548</b>
31.	Collar	All PWK	<b>1118-929-7000</b>	<b>018-550</b>
32.	Bowl Vent Pipe, Complete			
	PWK36 Quad Vent		16199-KZ3-6900	<b>018-537</b>
	PWK35 Quad Vent/Air Striker		16199-KZ3-6900	<b>018-537</b>
	PWK38 Quad Vent/Air Striker		16199-KZ3-6900	<b>018-537</b>
	O-Ring, Jet Block (not shown)		1202-834-2000	<b>021-532</b>

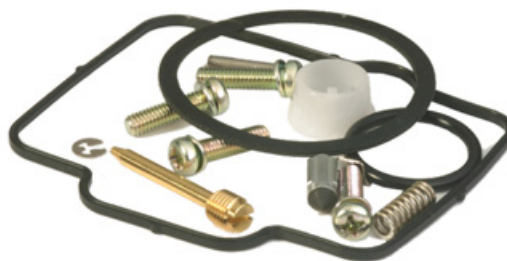

## Sudco PWK33 - 41mm Carburetor Rebuild Kit

Sudco rebuild kit for Keihin PWK33-41 carburetors contains GENUINE Keihin replacement parts. Sold as a kit.

Description	Application	Order No.
PWK33-41mm	Motorcycle	<b>020-110</b>

## PWK Throttle Valve Chart

	I.D. Mark	PWK33 N502-15x02	PWK35 N502-16x03	PWK36 Quad Vent N502-17x01	PWK38, 39, 41 N502-17x01	PWK35 Air Striker N502-15x02	PWK38 Air Striker N502-17x01
Rich	0	—————	<b>018-508</b>	<b>018-517</b>	<b>018-517</b>	—————	<b>018-517</b>
	3.0	—————	<b>018-509</b>	<b>018-518</b>	<b>018-518</b>	—————	<b>018-518</b>
	4.0	—————	<b>018-510</b>	<b>018-519</b>	<b>018-519</b>	—————	<b>018-519</b>
	4.5	<b>018-240</b>	—————	—————	—————	<b>018-240</b>	—————
	5.0	<b>018-241</b>	<b>018-511</b>	<b>018-520</b>	<b>018-520</b>	<b>018-241</b>	<b>018-520</b>
	5.5	<b>018-242</b>	—————	—————	—————	<b>018-242</b>	—————
	6.0	<b>018-243</b>	<b>018-512</b>	<b>018-521</b>	<b>018-521</b>	<b>018-243</b>	<b>018-521</b>
	6.5	<b>018-244</b>	—————	<b>018-525</b>	<b>018-525</b>	<b>018-244</b>	<b>018-525</b>
	7.0	<b>018-245</b>	<b>018-513</b>	<b>018-522</b>	<b>018-522</b>	<b>018-245</b>	<b>018-522</b>
	8.0	—————	—————	<b>018-523</b>	<b>018-523</b>	—————	<b>018-523</b>
	8.5	—————	<b>018-514</b>	—————	—————	—————	—————
	9.0	—————	—————	<b>018-524</b>	<b>018-524</b>	—————	<b>018-524</b>
Lean	9.5	—————	<b>018-515</b>	—————	—————	—————	—————

# KEIHIN PWK39 Snowmobile Exploded View

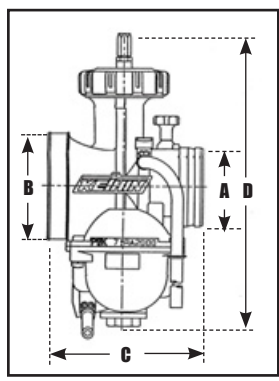
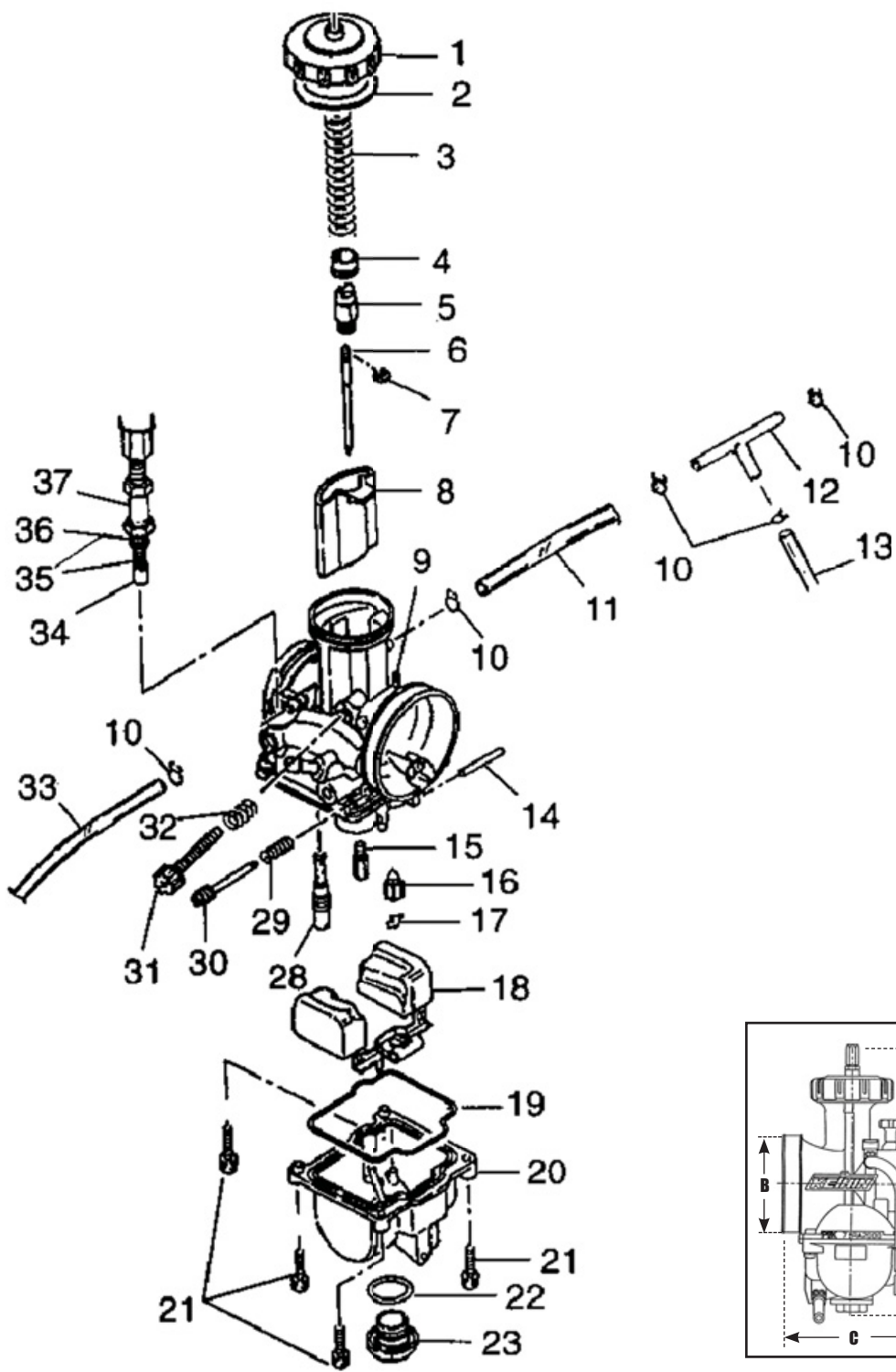

**Float Height**  
**19mm**

NOTE: Do not remove parts that are not shown on this extended view.

## PWK39 Carburetor Dimensions

Size (mm)	A	B	C	D
PWK39	46	63	91	171.6

## PWK39 Snowmobile Standard Jetting Specifications

Size (mm)	Main Jet	Slow Jet	Jet Needle	Throttle Valve	Float Height
PWK39	#190	#45	R-1369J	6.5	19mm





## PWK39 Snowmobile Replacement Parts

Keihin Part No. Highlighted in **BOLD RED** are included in rebuild kit.  
Applications: Polaris models with PWK39 carburetor.  
600XC, 600RMK, 700RMK, 700SKS, 700XC

No.	Description	Keihin No.	Order No.
1.	Top Cap	1030-840-2000	<b>018-528</b>
2.	Gasket, Top	<b>16110-ND5-7610-M1</b>	<b>021-518</b>
3.	Spring, Throttle	1290-921-2000	<b>018-531</b>
4.	Collar, Throttle Spring	<b>1118-A35-7000</b>	<b>021-524</b>
5.	Holder, Cable	1101-804-2000	<b>018-526</b>
6.	Clip, Jet Needle	<b>16155-169-0040</b>	<b>018-033</b>
7.	Jet Needle	W956R-XXXX Series	
	Jet Needle	W956R-1367J	<b>017-170</b>
	Jet Needle	W956R-1368G	<b>017-165</b>
	Jet Needle	W956R-1368J	<b>017-171</b>
	Jet Needle	W956R-1369G	<b>017-166</b>
	Jet Needle	W956R-1369J	<b>017-172</b>
	Jet Needle	W956R-1370G	<b>017-167</b>
	Jet Needle	W956R-1370J	<b>017-173</b>
	Jet Needle	W956R-1371G	<b>017-168</b>
	Jet Needle	W956R-1371J	<b>017-174</b>
	Jet Needle	W956R-1372G	<b>017-169</b>
	Jet Needle	W956R-1372J	<b>017-175</b>
8.	Throttle Valve	N502-17x-02	<b>Pg.137</b>
9.	Cap, Rubber	_____	_____
10.	Clip, Vent Bowl Pipe	_____	_____
11.	Pipe (Hose), Black Vent Bowl	_____	_____
12.	T-Joint	16143-KR3-7510-M1	<b>021-528</b>
13.	Pipe (Hose), Short Blk.Vent Bowl	_____	_____
14.	Float Pin	W9525-25250	<b>018-670</b>
15.	Main Jet	99101-357-xxx	<b>Pg.150</b>
16.	Float Valve (Needle Valve)	16155-ZG8-L100	<b>018-676</b>
		W9522-53001 (old number)	
17.	Clip, Float Valve	<b>0405-019-1000</b>	<b>018-674</b>
18.	Float	W1310-079-9921	<b>018-110</b>
19.	Gasket, Float Bowl	<b>16163-ND4-7510-M1</b>	<b>018-113</b>
20.	Float Bowl Comp.	Z050-355-000	<b>021-513</b>
21.	Screw, Float Bowl 4 x 16mm	<b>N114-04163</b>	<b>021-519</b>
22.	O-Ring, Plug Screw	16173-001-0040	<b>018-664</b>
23.	Plug Screw, Bowl	1018-807-2000	<b>021-514</b>
28.	Pilot Jet	N424-21-xxx	<b>Pg.148</b>
29.	Spring, Air Adjust	<b>W1711-416-9900</b>	<b>018-090</b>
30.	Screw, Air Adjust	<b>W1446-231-9900</b>	<b>018-089</b>
31.	Screw, Idle Adjuster	1034-867-2001	<b>021-522</b>
32.	Spring, Idle Adjuster	1290-A04-2000	<b>021-523</b>
33.	Pipe (Hose), Black Vent Bowl	_____	_____
34.	Valve, Starter (choke plunger)	_____	<b>021-512</b>
35.	Spring, Choke	1290-A05-2000	<b>021-526</b>
36.	O-Ring, Choke	0901-069-6000	<b>021-527</b>
37.	Cap, Starter	_____	_____

## Sudco PWK Snowmobile Carburetor Rebuild Kit

Sudco rebuild kit for the Keihin PWK39 snowmobile carburetor contains GENUINE Keihin replacement parts. Sold as a kit.

Order No. **020-111**

### Exploded

View No.	Qt	Contents
2.	1	Gasket, Top Cap
4.	1	Collar, Throttle Spring
6.	1	Clip, Jet Needle
16.	1	Float Valve (Needle Valve)
17.	1	Clip, Float Valve
19.	1	Gasket, Float Bowl
21.	4	Screw, Float Bowl 4 x 16mm
29.	1	Spring, Air Adjust
30.	1	Screw, Air Adjust



## Tokyomod's Drain Plug

Keeps all fuel contaminants including water away from the main jet, helps control fuel slosh and bogging, won't get distorted from over tightening, and easy to reach for quicker jetting changes. Machined from 6061 aluminum. Also fits Keihin FCR-MX, PJ, PWK, PWM, and PE carbs.

### Application

FCR-MX, PJ, PWK, PWM, PE

### Color

Red	<b>024-230R</b>
Blue	<b>024-230B</b>
Black	<b>024-230K</b>
Mag	<b>024-230M</b>

### Order No.



## Sudco Primer Kit

Sudco's primer kit is made of brass and includes fuel line and inline "T's". Plunger type operation. Made in the USA.

Order No. **002-995**

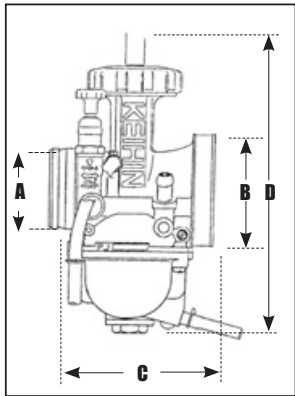
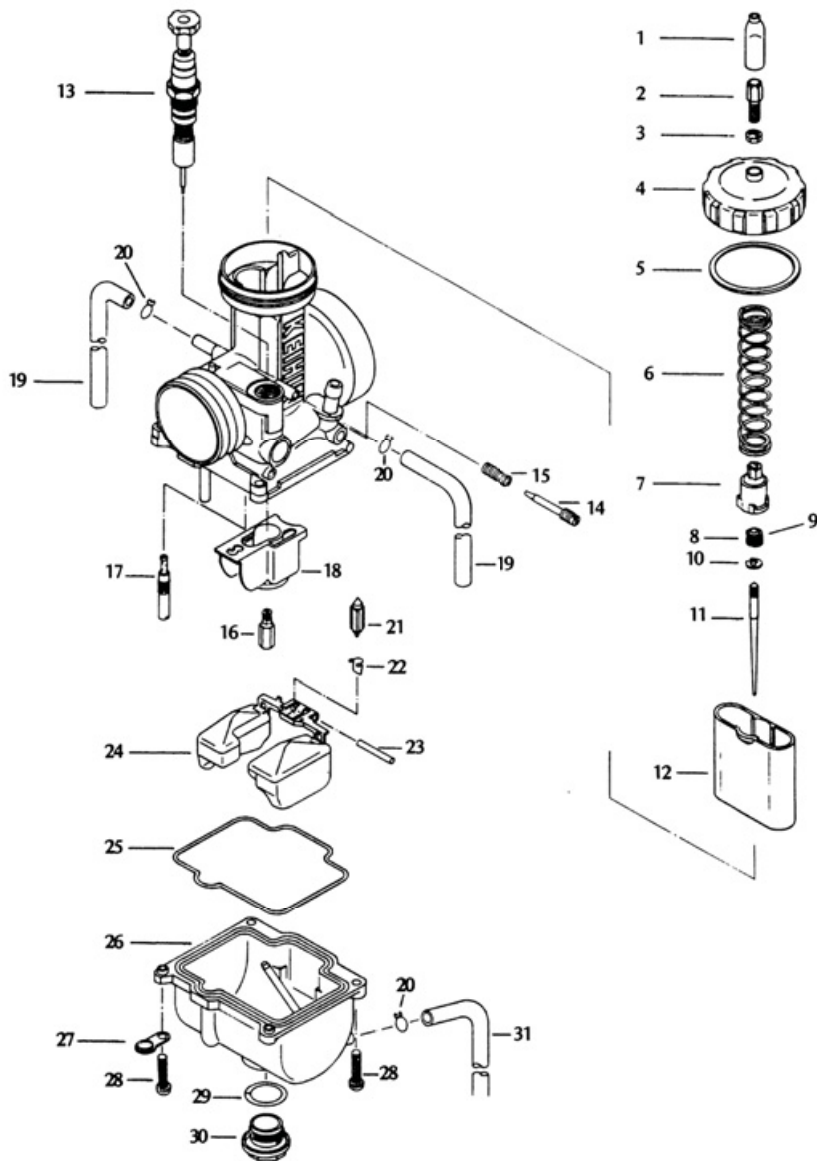

**NOTE:** Do not remove parts that are not shown on this extended view.

## PJ34 Carburetor Dimensions

Size (mm)	A	B	C	D
PJ34	41	59	91	174.0

**Float Height**  
16mm



## PJ34 Standard Jetting Specifications

Size (mm)	Main Jet	Slow Jet	Jet Needle	Throttle Valve	Float Height	Order No.
PJ34	#152	#55	48-CEG	6.0	16mm	<b>016-039</b>

## Tokyomod's Drain Plug

Keeps all fuel contaminants including water away from the main jet, helps control fuel slosh and bogging, won't get distorted from over tightening, and easy to reach for quicker jetting changes. Machined from 6061 aluminum. Also fits Keihin FCR-MX, PJ, PWK, PWM, and PE carbs.

Application	Color	Order No.
FCR-MX, PJ, PWK, PWM, PE	Red	<b>024-230R</b>
	Blue	<b>024-230B</b>
	Black	<b>024-230K</b>
	Mag	<b>024-230M</b>

## PJ Replacement Parts

Keihin Part No. Highlighted in **BOLD RED** are included in rebuild kit.

**Carb Top Kit** 34-36mm **018-975**

Includes the following parts:

**018-002, 018-005, 018-008, 018-011, 018-015.**

No.	Description	Application	Keihin No.	Order No.
1.	Cap,Cable Adjust	34-38mm	16118-166-0040	<b>018-002</b>
2.	Cable Adjuster	34-38mm	W9581-59250	<b>018-005</b>
3.	Nut, Cable Adjuster	34-38mm	W1793-130-9900	<b>018-008</b>
4.	Mixing Chamber,Top	34-36mm	W1591-130-9910	<b>018-011</b>
		38mm	W1591-131-9910	<b>018-012</b>
5.	Gasket, Top	34-36mm	<b>16110-NC8-0040</b>	<b>018-015</b>
		38mm	<b>16110-ND5-7610-M1</b>	<b>018-016</b>
6.	Throttle Spring	34mm	16050-KA3-7610-M1	<b>018-019</b>
		36mm	16050-KA4-7710-M1	<b>018-020</b>
		38mm	16050-KA5-6910-M1	<b>018-021</b>
7.	Cable Holder	34-38mm	16137-KA3-7610-M1	<b>018-024</b>
8.	Collar	34-38mm	W1706-052-9900	<b>018-027</b>
9.	Spring	34-38mm	16051-KA3-7610-M1	<b>018-030</b>
10.	Clip, Jet Needle	34-38mm	<b>16115-169-0040</b>	<b>018-033</b>
11.	Jet Needle	34-38mm	N427-48-xxx	<b>Pg.147</b>
12.	Throttle Valve	34mm	W1502-2J (X) -9900	<b>see chart</b>
		36mm	N502-22 (XX) -0-00	<b>see chart</b>
		38mm	N502-23 (XX) -0-00	<b>see chart</b>
13.	Starter Valve	34-36mm	16046-KA3-7610-M1	<b>018-085</b>
		38mm	16046-KA5-6911	<b>018-086</b>
14.	Air Adjustment Screw	34-38mm	<b>W1446-231-9900</b>	<b>018-089</b>
15.	Spring	34-38mm	<b>W1711-416-9900</b>	<b>018-090</b>
16.	Main Jet	34-38mm	99101-357-xxx	<b>Pg.150</b>
17.	Slow Jet	34-38mm	N424-21-xxx	<b>Pg.148</b>
18.	Baffle Plate	34-38mm	<b>16185-KA3-7610-M1</b>	<b>018-092</b>
19.	Air Vent Pipe	34-38mm	95003-07033-31	<b>021-752</b>
20.	Clip	34-38mm	W9535-35000	<b>018-098</b>
21.	Float Valve	34-38mm	<b>W1362-019-9900</b>	<b>018-101</b>
22.	Clip, Float Valve	34-38mm	<b>W1782-013-990</b>	<b>018-104</b>
23.	Float Pin	34-38mm	<b>W9525-25250</b>	<b>018-670</b>
24.	Float	34-38mm	W1310-079-9921	<b>018-110</b>
25.	O-Ring, Float Bowl	34-38mm	<b>16163-ND4-7510-M1</b>	<b>018-113</b>
26.	Float Bowl	34-38mm	W1350-289-9910	<b>018-006</b>
27.	Anchor Plate	34-38mm	16179-428-6711-M1	<b>018-119</b>
28.	Screw, Float Bowl	34-38mm	<b>93892-04016-18</b>	<b>018-122</b>
29.	Plug Screw O-Ring	34-38mm	<b>16173-001-0040</b>	<b>018-664</b>
30.	Main Jet Plug Screw	34-38mm	16162-ND4-7511-M1	<b>018-128</b>
31.	Overflow Tube	34-38mm	95003-05027-31	<b>018-131</b>



## 90° Cable Adjuster Assembly

This adjuster has threads on one end, the other end swivels.

Includes rubber cap, locknut, cable adjuster and 90° tube.

Works on Keihin and Mikuni carburetor caps.

Order No. **007-731**

## PJ Throttle Valve Chart

	Cutaway	PJ34	PJ36	PJ38
		W1505-2Jx-9900	N502-22xx0-01	N502-23xx0-01
Rich	4.0	<b>018-040</b>	<b>018-054</b>	<b>018-068</b>
	5.0	<b>018-042</b>	<b>018-056</b>	<b>018-070</b>
	6.0 (Std)	<b>018-044</b>	<b>018-058</b>	<b>018-072</b>
	7.0	<b>018-046</b>	<b>018-060</b>	<b>018-074</b>
Lean	8.0	<b>018-048</b>	<b>018-062</b>	<b>018-076</b>



## Keihin PJ Carburetor

Oval slide PJ34 carburetor for ATV and Offroad motorcycles.

The oval slide enables the engine to respond much quicker than with a conventional round slide carburetor.

Carburetor	Description/Mark	Order No.
PJ34 Standard	PJ34/67R	<b>016-039</b>

Use the following part number when ordering for special jetting request.

**Please note:** Special Set PJ carburetor is pre-jetted to your request or specific application. Please specify exact jetting details for each special set carburetor ordered.

PJ34 Special Set	PJ34/67R	<b>016-180</b>
------------------	----------	----------------



## Sudco PJ Carburetor Rebuild Kit

Sudco rebuild kit for the Keihin PJ34-38 contains GENUINE Keihin replacement parts. Sold as a kit.

Order No. **020-115**

Exploded

View No.	Qt	Contents
5.	1	Gasket, Top (PJ34, PJ36)
	1	Gasket, Top (PJ38)
10.	1	Clip, Jet Needle
14.	1	Air Adjustment Screw
15.	1	Spring
18.	1	Baffle Plate
21.	1	Float Valve
22.	1	Clip, Float Valve
23.	1	Float Pin
25.	1	O-Ring, Float Bowl
28.	4	Screw, Float Bowl
29.	1	Plug Screw O-Ring

# KEIHIN PWM 38 Exploded View

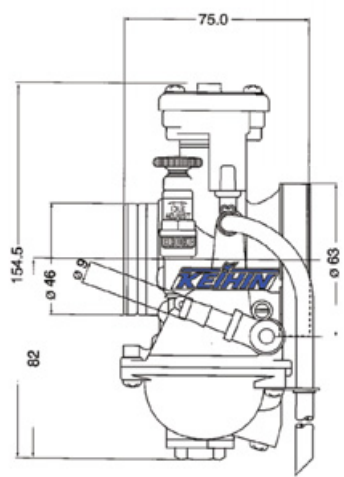
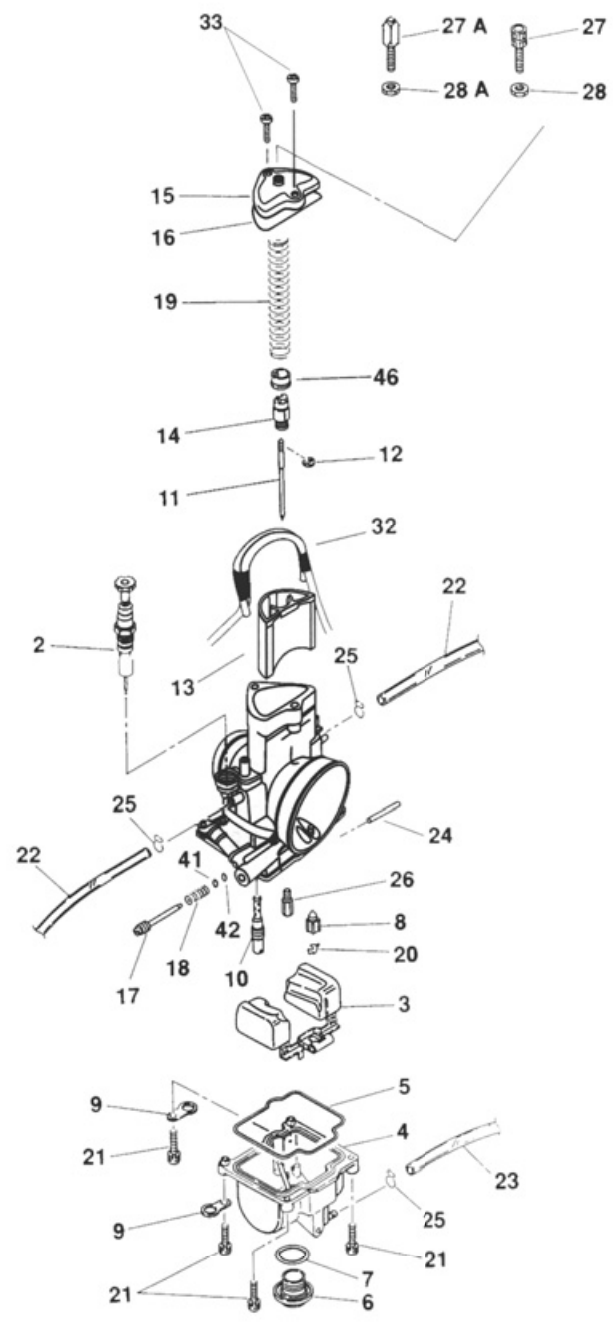

**NOTE:** Do not remove parts that are not shown on this extended view.

**Float Height**  
**6.5mm**

## PWM38 Carburetor Dimensions

Size (mm)	A	B	C	D
PWM38 Quad Vent	46	63	75	154.5

## PWM38 Quad Vent Standard Jetting Specifications

Size (mm)	Main Jet	Slow Jet	Jet Needle	Throttle Valve	Float Height	Keihin No.	Order No.
PWM38	#175	#50	48-CCJ	6.0	6.5mm	PWM38/S64	016-170

## PWM Replacement Parts

Keihin Part No. Highlighted in **BOLD RED** are included in rebuild kit.

No.	Description	Keihin No.	Order No.
2.	Starter Valve Complete	1166-834-2200	<b>018-201</b>
3.	Float	1052-856-2100	<b>018-202</b>
4.	Float Bowl Complete	1050-898-2100	<b>018-203</b>
5.	Gasket, Float Bowl	<b>16163-ND4-7510-M1</b>	<b>018-113</b>
6.	Plug Screw	16162-ND4-7511-M1	<b>018-128</b>
7.	O-Ring, Plug Screw	<b>16173-001-0040</b>	<b>018-664</b>
8.	Float Valve Complete	<b>1062-814-2100</b>	<b>018-504</b>
9.	Anchor Plate	16174-KZ4-6900	<b>018-204</b>
10.	Slow Jet	N424-21-xxx	<b>Pg.148</b>
11.	Jet Needle	N427-48-xxx	<b>Pg.147</b>
12.	Clip, Jet Needle	<b>16115-169-0040</b>	<b>018-033</b>
13.	Throttle Valve	N502-31x00	<b>See chart</b>
14.	Cable Holder	1101-805-2000	<b>018-205</b>
15.	Top	1030-872-2000	<b>018-206</b>
16.	Gasket, Top	<b>1202-863-6000</b>	<b>018-207</b>
17.	Air Adjust Screw	<b>W1446-231-9900</b>	<b>018-089</b>
18.	Spring, Air Adjust Screw	<b>W1711-416-9900</b>	<b>018-090</b>
19.	Spring, Throttle Valve	1290-920-2000	<b>018-531</b>
20.	Clip, Float Valve	<b>0405-019-1000</b>	<b>018-674</b>
21.	Screw, Float Bowl	<b>93500-04014-1H</b>	<b>018-209</b>
22.	Bowl, Vent Pipe	95003-07048-31	<b>018-535</b>
23.	Overflow Pipe	95003-05033-31	<b>018-538</b>
24.	Float Pin	<b>W9525-25250</b>	<b>018-670</b>
25.	Clip	W9535-35000	<b>018-098</b>
26.	Main Jet (hex type)	99101-357-xxx	<b>Pg.150</b>
27A.	Cable Adjuster	W9581-59250	<b>018-005</b>
27B.	Cable Adjuster	W9581-59200	<b>018-306</b>
28.	Nut, Cable Adjuster	0208-007-1100	<b>018-544</b>
28A.	Nut, Cable Adjuster	W1793-130-9900	<b>018-008</b>
31.	Cable Sealing Cap (Collar)	16118-166-0040	<b>018-002</b>
32.	Bowl Vent Pipe Complete	16199-KZ3-6900	<b>018-537</b>
33.	Screw (Top)	<b>93500-04012-1H</b>	<b>018-211</b>
41.	Washer	<b>16085-KG8-9010-M1</b>	<b>018-208</b>
42.	O-Ring	<b>16075-KG8-9010-M1</b>	<b>021-043</b>
46.	Collar	1118-929-7000	<b>018-550</b>



## Keihin PWM38 Carburetor

The Keihin PWM38 carburetor is the "Hot Ticket" for 125 to 250cc Road Racing and Shifter Kart applications and 250cc Motocross. The exclusive features built into the Keihin PWM38 result in improved top-end power, throttle response, and overall two-stroke engine performance. PWM38 carburetor sold standard jetting or Special Set, please specify when ordering.

Carburetor	Order No.
PWM38 Quad Vent	<b>016-170</b>
<b>Please note:</b> Special Set PWM carburetor is pre-jetted to your request or specific application. Please specify exact jetting details for each special set carburetor ordered.	
PWM38 Quad Vent	<b>016-204</b>

## PWM Throttle Valve Chart

	Cutaway	Keihin No.	Order No.
Rich ↑	4.0	N502-31C00	<b>018-252</b>
	5.0	N502-31D00	<b>018-253</b>
	6.0 (Std)	N502-31E00	<b>018-254</b>
	7.0	N502-31F00	<b>018-255</b>
Lean ↓	8.0	N502-31G00	<b>018-256</b>



## Tokyomods Drain Plug

Keeps all fuel contaminants including water away from the main jet, helps control fuel slosh and bogging, won't get distorted from over tightening, and easy to reach for quicker jetting changes. Machined from 6061 aluminum. Also fits Keihin FCR-MX, PJ, PWK, PWM, and PE carbs.

Application	Color	Order No.
FCR-MX, PJ, PWK, PWM, PE	Red	<b>024-230R</b>
	Blue	<b>024-230B</b>
	Black	<b>024-230K</b>
	Mag	<b>024-230M</b>



## Sudco PWM38 Carburetor Rebuild Kit

Sudco rebuild kit for the Keihin PWM contains GENUINE Keihin replacement parts. Sold as a kit.

Order No. **020-120**

### Exploded

View No.	Qt	Contents
5.	1	Gasket, Float Bowl
7.	1	O-Ring, Plug Screw
8.	1	Float Valve Complete
12.	1	Clip, Jet Needle
16.	1	Gasket, Top
17.	1	Air Adjust Screw
18.	1	Spring, Air Adjust Screw
20.	1	Clip, Float Valve
21.	4	Screw, Float Bowl
24.	1	Float Pin
33.	2	Screw (Top)
41.	1	Washer
42.	1	O-Ring

# KEIHIN PE Exploded View

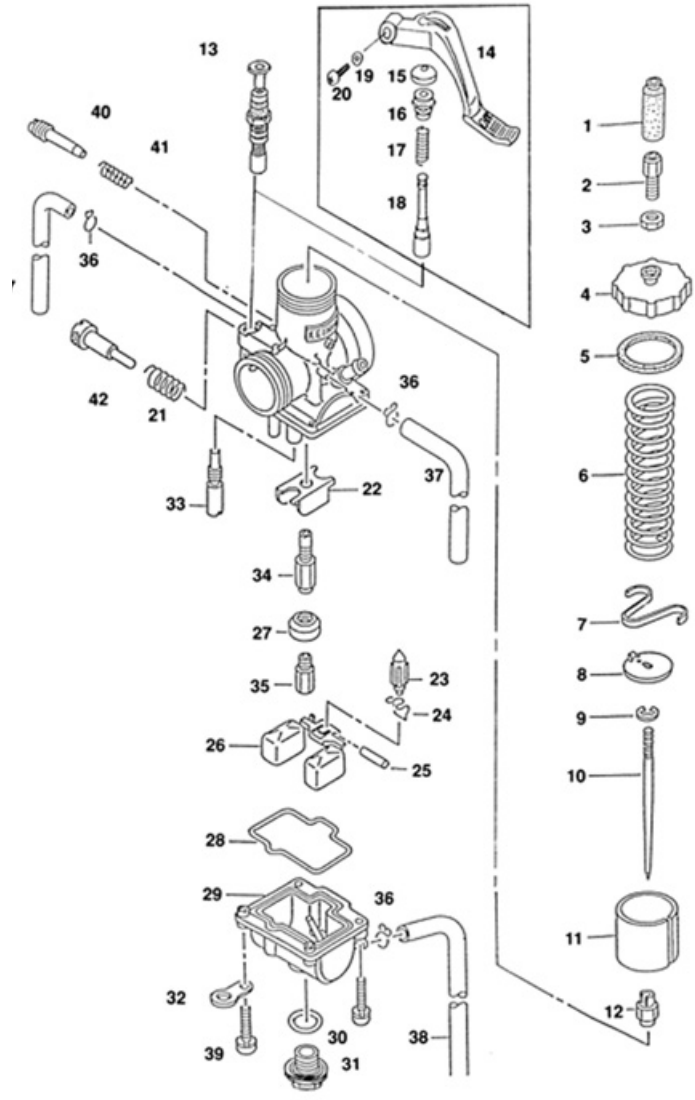

## Keihin PE Series Carburetor

Whether you want a tunable performance carburetor or a replacement for your worn out original, the PE series is the right choice. Available sizes include PE20, 22, 24, 28 and PE38.

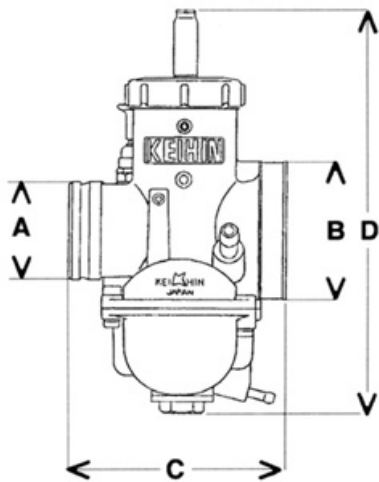

**Float Height**  
See Specifications

NOTE: Do not remove parts that are not shown on this extended view.

## PE Carburetor Dimensions

Size (mm)	A	B	C	D
PE20	31	46	83	136
PE22	31	46	83	136
PE24	31	46	83	142.1
PE28	35	50	83	150.9
PE38	44	62	95	182.5

## PE Standard Jetting Specifications

Size (mm)	Main Jet	Slow Jet	Jet Needle	Throttle Valve	Float Height	Keihin No.	Order No.
PE20	#100	#58	36S00	4.0	19mm	PE20/R69	<a href="#">016-122</a>
PE22	#102	#40	94D00	3.5	19mm	PE22/18S	<a href="#">016-123</a>
PE24	#115	#52	36S00	3.0	19mm	PE24/S14	<a href="#">016-126</a>
PE28	#125	#40	46-JFN	2.0	19mm	PE28/R37	<a href="#">016-127</a>
PE38	#160	#60	48-AJM	3.5	22.5mm	PE38/R50	<a href="#">016-124</a>

## PE Throttle Valve Chart

	Cutaway PE20 G1502-QUx-9900	PE22 G1502-QHx-9900	PE24 G1502-1Sx-9900	PE38 G1502-04G-9900
Rich	2.0	2.0	2.0	2.0
	2.5	2.5	2.5	2.5
	3.0	3.0	3.0	3.0
	3.5	3.5	3.5	3.5
	4.0	4.0	<a href="#">021-374</a>	<a href="#">021-330</a>
	4.5	4.5	4.5	4.5
	5.0	5.0	5.0	5.0
	5.5	5.5	5.5	5.5
Lean	6.0	6.0	6.0	6.0



## Tokyomod's Drain Plug

Keeps all fuel contaminants including water away from the main jet, helps control fuel slosh and bogging, won't get distorted from over tightening, and easy to reach for quicker jetting changes. Machined from 6061 aluminum. Fits Keihin FCR-MX, PJ, PWK, PWM, and PE carbs.

See page 143 for colors, and order numbers



## PE Replacement Parts

No. Description	Application	Keihin No.	Order No.
1. Cap Cable Holder	20-24mm	16118-166-0040	<b>018-002</b>
	30mm	16118-166-0040	<b>018-002</b>
	34-38mm	W1597-023-9900	<b>018-303</b>
2. Cable Adjuster	20-24mm	W9581-59250	<b>018-005</b>
	30mm	W9581-59250	<b>018-005</b>
	34-38mm	W9581-59200	<b>018-306</b>
3. Nut, Cable Adjuster	20-24mm	W1793-130-9900	<b>018-008</b>
	30mm	W1793-130-9900	<b>018-008</b>
	34-38mm	W1793-121-9900	<b>018-309</b>
4. Top	20-24mm	G591-145-9900	<b>021-565</b>
	36-38mm	G591-093-9900	<b>021-781</b>
5. Gasket	20-24mm	W1593-040-9900	<b>018-320</b>
	26-28mm	W1593-039-9900	<b>021-798</b>
	36-38mm	W1593-038-9900	<b>021-782</b>
	20mm	G1711-614-9900	<b>021-566</b>
6. Throttle Spring	22mm	16050-GF5-6710-M1	<b>021-785</b>
	24mm	16050-GF5-7410-M1	<b>021-784</b>
	36-38mm	G1711-484-9900	<b>021-783</b>
	20-24mm	16114-GF5-0040	<b>021-567</b>
7. Clip, T.V. Plate	26-28mm	W9574-20000	<b>018-338</b>
	36-38mm	W9574-3500	<b>018-341</b>
	22-24mm	W1506-028-9900	<b>018-344</b>
8. Throttle Valve Plate	36-38mm	G1506-017-9900	<b>021-786</b>
	20-38mm	16115-169-0040	<b>018-033</b>
9. Clip, Jet Needle	20-24mm	G1427-36x-9900	<b>See chart</b>
10. Jet Needle		1024-36x-9900-old number	
	26-28mm	N427-46-xxx	<b>Pg.147</b>
	34-38mm	N427-48-xxx	<b>Pg.147</b>
	20mm	G1502-OUx-9900	_____
	22mm	G1502-OHx-9900	_____
11. Throttle Valve	24mm	G1502-1Sx-9900	<b>Pg.144</b>
	38mm	G1502-04G-9900	<b>Pg.144</b>
	20-26mm	16164-169-0040	<b>018-560</b>
	26-28mm	16046-KA5-7710-M1	<b>021-584</b>
12. Needle Jet	36-38mm	16046-KA5-7710-M1	<b>021-584</b>
13. Choke Valve	20-24mm	1165-031H-9900	<b>021-568</b>
14. Choke Lever	20-24mm	16148-PJ7-0051	<b>021-569</b>
15. Rubber Cap	20-24mm	W1551-035-9901	<b>018-362</b>
16. Choke Lever Holder	20-24mm	W1711-403-9900	<b>018-372</b>
17. Choke Valve Spring	20-24mm	W1275-020-9900	<b>018-358</b>
18. Choke Valve	20-24mm	W1704-362-9900	<b>021-570</b>
19. Collar	20-24mm	93500-04012-1H	<b>018-211</b>
20. Screw	20-28mm	16052-KG8-9010-M1	<b>018-382</b>
	30-38mm	G1711-286-9901	<b>018-383</b>
21. Spring	34-38mm	G1130-004-9900	<b>021-585</b>
	20-28mm	W1362-020-9901	<b>018-389</b>
22. Baffle Plate	30-38mm	W1362-024-9900	<b>021-787</b>
23. Float Valve	20-38mm	W1782-013-9900	<b>018-104</b>
24. Clip, Float Valve	20-38mm	W9525-25250	<b>018-670</b>
25. Float Pin	20-22mm	W1310-067-9902	<b>018-396</b>
26. Float	24mm	W1310-080-9901	<b>018-397</b>
	26mm	W1310-067-9902	<b>018-396</b>
	28mm	W1310-080-9902	_____
	30-36mm	G1310-059-9901	<b>021-789</b>
	38mm	G1310-058-9911	<b>021-788</b>
27. Jet Holder	20-28mm	16168-GC4-7010-M1	<b>018-402</b>
	30-38mm	16168-KA4-0040	<b>018-403</b>
28. Gasket, Float Bowl	20-28mm	W1354-042-9900	<b>018-406</b>
	30-38mm	16163-ND4-7510-M1	<b>018-113</b>
29. Float Bowl	20-22mm	W1350-239-9903	<b>018-409</b>
	24mm	W1350-291-9901	<b>021-791</b>
	30-38mm	W1350-189-9910	<b>021-790</b>
30. Plug Screw O-Ring	20-38mm	16173-001-0040	<b>018-664</b>
31. Plug Screw	20-38mm	16162-ND4-7511-M1	<b>018-128</b>
32. Anchor Plate	30-38mm	16179-428-6711-M1	<b>018-119</b>
33. Slow Jet	20-22mm	N424-21-xxx	<b>Pg.148</b>
	24mm	N424-32-xxx	<b>Pg.148</b>
	26-30mm	N424-21-xxx	<b>Pg.148</b>
	34-38mm	N424-22-xxx	<b>Pg.148</b>

No. Description	Application	Keihin No.	Order No.
34. Needle Jet	20mm	G1413-34A-9900	<b>021-793</b>
	22mm	16165-GC4-7010-M1	<b>021-794</b>
	24-28mm	G1413-34A-9900	<b>021-793</b>
	30-38mm	16164-KA5-0041	<b>021-792</b>
35. Main Jet	20-38mm	99101-357-xxx	<b>Pg.150</b>
36. Clip/Pipe	20-38mm	W9535-35000	<b>018-098</b>
37. Bowl, Vent Pipe	20-28mm	95003-07027-31	<b>021-571</b>
	34-38mm	95003-07039-31	<b>021-795</b>
38. Overflow Pipe	20-28mm	95003-07030-31	_____
	30-38mm	95003-05030-31	<b>021-796</b>
39. Screw, Float Bowl	20-38mm	93892-04016-18	<b>018-122</b>
40. Air Adjust Screw	20-22mm	16080-KG8-9010-M1	<b>021-573</b>
	24mm	W1446-135-9900	<b>021-797</b>
	26-38mm	16080-KG8-9010-M1	<b>021-573</b>
41. Spring	20-38mm	W1711-416-9900	<b>018-090</b>
42. Throttle Stop Screw	20-22mm	W1536-120-9900	<b>021-574</b>
	24-28mm	W1536-105-9901	<b>018-378</b>
	30-38mm	W1536-065-9900	<b>018-379</b>

### Cable Adjuster Holder

Cable adjuster holder to be used with Keihin PE20-28 Throttle Stop Screw (#42).

Order No. **021-799**

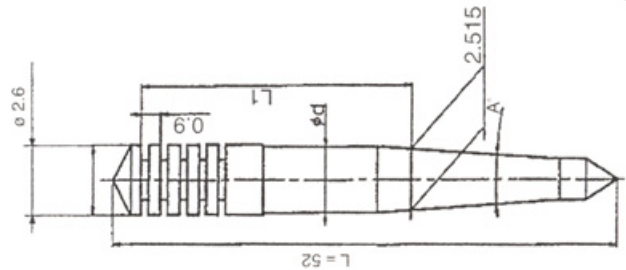

### PE20-24mm Jet Needles

Jet Needle selection notes: (see chart at bottom)

1. Taper and diameter are the 2 primary dimensions. Larger diameter is leaner at low speeds.
2. Larger taper angle becomes richer faster as speed increases.
3. If diameter and taper are the same, larger L1 will stay leaner longer.
4. A higher clip position will stay lean longer.

### 1024-36 ( ) H-9900

Mark	Taper A	L1 Length	Diameter D	Order No.
A	2° 00'	21.98	2.485	<b>017-700</b>
B	2° 00'	22.43	2.435	<b>017-701</b>
C	2° 00'	22.43	2.495	<b>017-702</b>
D	2° 00'	21.98	2.495	<b>017-703</b>
E	2° 00'	23.78	2.445	<b>017-704</b>
F	2° 26'	23.84	2.525	<b>017-705</b>
G	3° 00'	23.89	2.515	<b>017-706</b>
H	3° 00'	23.89	2.525	<b>017-707</b>
J	3° 00'	23.89	2.535	<b>017-708</b>
K	3° 00'	23.89	2.505	<b>017-709</b>
L	3° 33'	27.22	2.485	<b>017-710</b>
N	3° 33'	23.92	2.545	<b>017-712</b>
P	3° 33'	27.22	2.475	<b>017-713</b>
Q	3° 33'	27.22	2.525	<b>017-714</b>
R	3° 33'	27.22	2.545	<b>017-715</b>
S	3° 33'	25.72	2.475	<b>017-716</b>

# KEIHIN Jet Needle for PE, PJ, PWK, PWM

**N427-48** PJ34-38, PE36, PWK33-39, PWM38

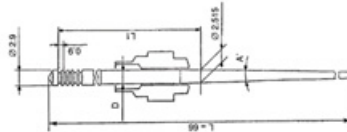
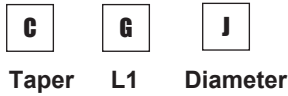

Operations affected by needle selection

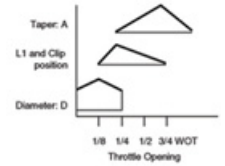

		1/8 to 1/4 Throttle														Lean	
		Diameter (d-1) mm															
Taper (A) (L1) length in degrees in mm		A=2.605	B=2.615	C=2.625	E=2.645	F=2.655	G=2.665	H=2.675	J=2.685	K=2.695	L=2.705	M=2.715	N=2.725	P=2.735	Q=2.745		
A 1' 00'	C=36.35	---	---	---	---	---	---	---	---	---	---	---	---	---	---	---	RICH ↑ ↓ LEAN
	E=38.15	---	---	---	---	---	---	---	---	---	---	---	---	---	---	---	
	G=39.95	---	---	---	---	---	---	---	---	---	---	---	---	---	---	---	
	J=41.75	---	---	---	---	---	---	---	---	---	---	---	---	---	---	---	
B 1' 15'	C=36.35	---	---	---	---	---	---	---	---	---	---	---	---	---	---	---	RICH ↑ ↓ LEAN
	E=38.15	---	---	---	---	---	---	---	---	---	---	---	---	---	---	---	
	G=39.95	---	---	---	---	---	---	---	---	---	---	---	---	---	---	---	
C 1' 34'	C=36.35	---	---	---	---	---	---	---	---	---	---	---	---	---	---	---	RICH ↑ ↓ LEAN
	E=38.15	---	---	---	---	---	---	---	---	---	---	---	---	---	---	---	
	G=39.95	---	---	---	---	---	---	---	---	---	---	---	---	---	---	---	
D 1' 45'	C=36.35	DCA/017-484	---	---	---	---	---	---	---	---	---	---	---	---	---	---	RICH ↑ ↓ LEAN
	D=36.80	DDA/017-496	---	---	---	---	---	---	---	---	---	---	---	---	---	---	
	E=38.15	---	---	---	---	---	---	---	---	---	---	---	---	---	---	---	
	G=39.95	---	---	---	---	---	---	---	---	---	---	---	---	---	---	---	
E 2' 00'	C=36.35	ECA/017-442	ECB/017-437	ECC/017-438	ECE/017-440	ECF/017-441	ECG/017-443	ECH/017-444	ECJ/017-445	ECK/017-446	ECL/017-447	---	ECN/017-448	---	---	---	RICH ↑ ↓ LEAN
	E=38.15	---	---	---	---	---	---	---	---	---	---	---	---	---	---	---	
	G=39.95	---	---	---	---	---	---	---	---	---	---	---	---	---	---	---	
F 2' 15'	E=38.15	---	---	---	---	---	---	---	---	---	---	---	---	---	---	---	
	F=38.60	---	---	---	---	---	---	---	---	---	---	---	---	---	---	---	
G 2' 26'	F=38.60	---	---	---	---	---	---	---	---	---	---	---	---	---	---	---	
	F=38.60	---	---	---	---	---	---	---	---	---	---	---	---	---	---	---	
J 3'	F=38.60	---	---	---	---	---	---	---	---	---	---	---	---	---	---	---	

## OEM-N427-48-□□□ Series Conversion Chart

\* Not all OEM needles are available as option needles.

### 1. How To Read Marks

#### 1) Mark on OEM Jet Needle (6 digits)

- 1st digit of MARK on OEM's tells you the KEIHIN Part Number
- NEXT TWO DIGITS (2nd & 3rd) tell you TAPER angle.
- NEXT TWO DIGITS (4th & 5th) tell you DIAMETER of needle.
- LAST DIGIT (6th) tells you L1.

#### 2) Mark on Option Jet Needle (3 digits)

- 1st digit is for TAPER angle.
- 2nd digit is for L1.
- LAST digit is for DIAMETER.

### 2. Conversion Table

1) TAPER		2) DIAMETER				3) L1	
OEM	OPTION	OEM	OPTION	OEM	OPTION	OEM	OPTION
11	B Lean	60	A Rich	72	N Rich	A	A Rich
13	C ↑	61	B ↑	73	P ↑	B	B ↑
14	D ↓	62	C ↓	74	Q ↓	E	C ↓
20	E ↓	63	D ↓	75	R ↓	F	D ↓
22	F ↓	64	E ↓	76	S ↓	J	E ↓
30	J Rich	65	F ↓	77	T ↓	K	F ↓
		66	G ↓	78	U ↓	N	G ↓
		67	H ↓	79	V ↓	P	H ↓
		68	J ↓	80	W ↓	S	J ↓
		69	K ↓	81	X ↓	T	K ↓
		70	L ↓	82	Y ↓	W	L ↓
		71	M Lean	83	Z Lean	Y	M Lean

### 3. Examples for Conversion

OEM	NEEDLE	OPTION
R 1 1 6 6 J	→	B E G
R 1 3 6 8 N	→	C G J
R 1 4 7 0 N	→	D G L
R 2 0 7 2 N	→	E G N

Taper | Diameter
L1

The MARK ORDER of OEM needle is NOT the same as OPTION's. DO NOT FORGET IT.

### N84x, N85x Jet Needle to N428-48xxx

OEM MARK	OPTION MARK	OEM MARK	OPTION MARK
N84A	CFF	N84I	CFP
N84B	CFG	N84J	CFQ
N84C	CFH	N84K	CFR
N84D	CFJ	N85A	CCF
N84E	CFK	N85B	CCG
N84F	CFL	N85C	CCH
N84G	CFM	N85D	CCJ
N84H	CFN	N85E	CCK

NOTE: N84x series are dual taper, N85x series are triple taper, therefore this chart will only give approximate comparison. Change main jet to two size larger with N428-48 series for N85 series.



## N427-46 PE26-28, PWK28

J    J    H  
**Taper L1 Diameter**

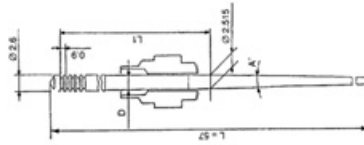

Operations affected by needle selection

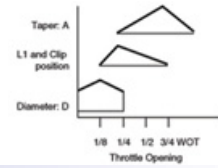

		Rich ←		1/8 to 1/4 Throttle												→ Lean	
				Diameter (d-1) mm													
				D=2.395	E=2.405	F=2.415	G=2.425	H=2.435	J=2.445	K=2.455	L=2.465	M=2.475	N=2.485	P=2.495	Q=2.505	S=2.525	
LEAN	1/4 to 3/4 Throttle	Taper (A) in degrees	(L1) length in mm														
				RICH													
		LEAN															
		RICH															
		LEAN															
		RICH															
		LEAN															
		RICH															
		LEAN															
		RICH															
		LEAN															
		RICH															
		LEAN															
		RICH															
		LEAN															
		RICH															
		LEAN															

## N427-68 Keihin PWK28 (N68A) (Twin Taper Needle)

             
**Taper L1 Diameter**

		Rich ←		1/8 to 1/4 Throttle												→ Lean	
				Diameter (d-1) mm													
				O=2.435													
LEAN	1/4 to 3/4 Throttle	Taper (A) in degrees	(L1) length in mm														
				RICH													
		LEAN															
		RICH															
		LEAN															

## N427-5 Keihin Harley Davidson CVH

MA    H    R  
**Taper L1 Diameter**

		Rich ←		1/8 to 1/4 Throttle												→ Lean	
				Diameter (d-1) mm													
				R=2.750	S=2.760												
LEAN	1/4 to 3/4 Throttle	Taper (A) in degrees	(L1) length in mm														
				RICH													
		LEAN															

# KEIHIN Slow Jets (Pilot)

## N424-21-XXX

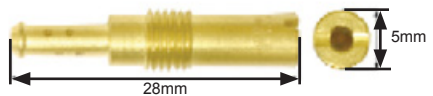

**Applications:** Aftermarket CVK20, Aftermarket and OEM FCR-MX, PD22, PE20, 26, 28, 30mm, PJ34, 36, 38mm, PWM 34, 36, 38mm, PWK28, 33, 35, 38, 39mm, PWK36 Quad Vent, PWK 35, 38 Quad Vents/Air Strikers, **Honda** CBR1000F Hurricane (87-88), GL1500 Valkyrie, ATC200 (81-83), ATC250R (83-84), FL350R Odyssey (1985), FL400 Pilot (88-89), TRX450R (2006), CRF450R (02-05), CR500R, XR650R, **Kawasaki** KX125, KX250, KX500 with Keihin PWK carburetor.

Size	Order No.	Size	Order No.	Size	Order No.
#35	019-005	#50	019-011	#65	019-017
#38	019-006	#52	019-012	#68	019-018
#40	019-007	#55	019-013	#70	019-019
#42	019-008	#58	019-014	#72	019-020
#45	019-009	#60	019-015	#75	019-021
#48	019-010	#62	019-016	#78	019-022
				#80	019-023

## N424-22-XXX



**Applications:** PE Series - PE34, 36, 38mm, **Honda** ATC250R (81-82) **Kawasaki** V-Twin CVK - VN700A Vulcan 700, VN750A Vulcan 750 (86-06), VN1500 Vulcan 1500 (87-99)

Size	Order No.	Size	Order No.	Size	Order No.
#35	019-030	#52	019-037	#70	019-044
#38	019-031	#55	019-038	#72	019-045
#40	019-032	#58	019-039	#75	019-046
#42	019-033	#60	019-040	#78	019-047
#45	019-034	#62	019-041	#80	019-048
#48	019-035	#65	019-042		
#50	019-036	#68	019-043		

## N424-24-XXX



**Applications:** CR Special (CRS) 26 - 33mm & 35 - 39mm Carburetors, **Honda** 99103-358-000, CR125R (79-80), CR250M (1976), CR250R (78-80), FL250 Odyssey (77-84)

Size	Order No.	Size	Order No.	Size	Order No.
#35	019-060	#52	019-067	#70	019-074
#38	019-061	#55	019-068	#72	019-075
#40	019-062	#58	019-069	#75	019-076
#42	019-063	#60	019-070	#78	019-077
#45	019-064	#62	019-071	#80	019-078
#48	019-065	#65	019-072	#82	019-079
#50	019-066	#68	019-073		

## N424-33-XXX

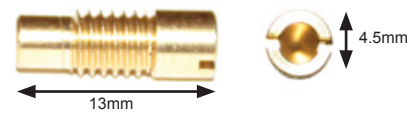

**Applications:** OEM FCR-MX Carburetors, **Honda** CRF250/450R, CRF250/450X, TRX450ER/R (06-08), **Husqvarna** SM610, **Kawasaki** KX250F, KX450F, KLX450R, **Polaris** Outlaw 525 (07-08), **Suzuki** RM-Z250, RM-Z450, **Yamaha** WR250F (2003) YZ250F (2003) YFZ450R, YZ450F (2003) WR450F (2003)

## N424-25B-XXX

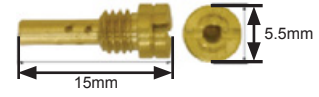

**Applications:** FCR Horizontal and Downdraft Series FCR28, 32, 33, 35, 37, 39, 41mm, **Arctic Cat** ATV with CVK carburetor, **Harley-Davidson**® w/Keihin BD (Screamin Eagle) and Keihin BH (non CV type), **Kawasaki** models with CVK and FCR carburetors, (**VN700/750/1500 Vulcan with CVK see N424-22-XXX**) **Yamaha** YZF600R (95-07), **Yamaha** Snowmobile with Keihin BD carburetor.

Size	Order No.	Size	Order No.	Size	Order No.
#35	019-810	#58	019-819	#80	019-828
#38	019-811	#60	019-820	#82	019-829
#40	019-812	#62	019-821	#85	019-830
#42	019-813	#65	019-822	#88	019-831
#45	019-814	#68	019-823	#90	019-832
#48	019-815	#70	019-824	#92	019-833
#50	019-816	#72	019-825	#95	019-834
#52	019-817	#75	019-826	#98	019-835
#55	019-818	#78	019-827		

## N424-26-XXX

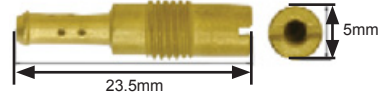

**Applications:** Keihin PE Series - PE20, 26, 28, 30mm, Some **Honda** VB Series using 99101-MA4 jets, **Honda** 99103-G46-000, 99103-MA4-000, XR400, CBX, **Honda** XR650L **Honda** ATV ATC250ES, ATC250SX, TRX250 (1985), .

Size	Order No.	Size	Order No.	Size	Order No.
#35	019-540	#52	019-547	#70	019-554
#38	019-541	#55	019-548	#72	019-555
#40	019-542	#58	019-549	#75	019-556
#42	019-543	#60	019-550	#78	019-557
#45	019-544	#62	019-551	#80	019-558
#48	019-545	#65	019-552		
#50	019-546	#68	019-553		

## N424-32-XXX

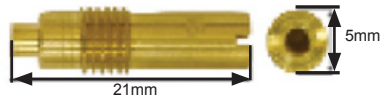

**Applications:** Keihin PE Series - PE24 only.

Size	Order No.	Size	Order No.	Size	Order No.
#35	019-080	#48	019-085	#60	019-090
#38	019-081	#50	019-086	#62	019-091
#40	019-082	#52	019-087	#65	019-092
#42	019-083	#55	019-088	#68	019-093
#45	019-084	#58	019-089	#70	019-094

Size	Order No.	Size	Order No.
#80	019-1014	#100	019-1018
#85	019-1015	#105	019-1019
#90	019-1016	#110	019-1020
#95	019-1017	#115	019-1021

## N424-35-XXX

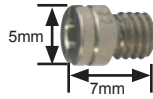

Nickel plated slow jets to prevent corrosion.  
**Applications:** CDK, CDKII 38 & 42 Watercraft Carburetors,  
**Kawasaki** OEM Jet-Ski with CDK carburetors.

Size	Order No.	Size	Order No.	Size	Order No.
#50	019-630	#75	019-640	#100	019-650
#52	019-631	#78	019-641	#102	019-651
#55	019-632	#80	019-642	#105	019-652
#58	019-633	#82	019-643	#108	019-653
#60	019-634	#85	019-644	#110	019-654
#62	019-635	#88	019-645	#112	019-655
#65	019-636	#90	019-646	#115	019-656
#68	019-637	#92	019-647	#118	019-657
#70	019-638	#95	019-648	#120	019-658
#72	019-639	#98	019-649		

## N424-74C-XXX

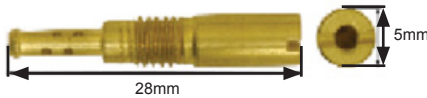

**Applications:** Arctic Cat 650 V-Twin ATV, Honda Ruckus,  
**Kawasaki** KLX110, V-Twin ATV with CVKR-D, KSV700A/B KFX,  
 KVF750, **Suzuki** DR-Z110, V-Twin ATV with CVKR-D, LTF700 Twin  
 Peaks, **KTM** 950 Adventurer, **Yamaha** YZF-R6 (99-02).

Size	Order No.	Size	Order No.	Size	Order No.
#35	019-840	#48	019-845	#60	019-850
#38	019-841	#50	019-846	#62	019-851
#40	019-842	#52	019-847	#65	019-852
#42	019-843	#55	019-848	#68	018-853
#45	019-844	#58	019-849	#70	019-854

## FCR Slow Air Jet 99101-124-XXX (99101-ZF5-XXX)

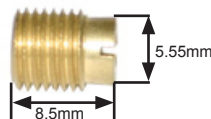

**Applications:** Keihin FCR Horizontal and Downdraft Series carburetors, FCR28, 32, 33, 35, 37, 39, 41mm.  
**Honda** Metropolitan, Ruckus, **Kawasaki** CVK carbs, OEM Primary Main Jet, KZ250 LTD & CSR (80-83), KZ305A/B CSR (81-82), KZ305B CSR Belt (87-88), KZ440A/B/D/G (80-83), KZ750E (80-82), KZ750H LTD (80-83), KZ750N Spectre (82-83).

Size	Order No.	Size	Order No.	Size	Order No.
#48	019-402	#80	019-415	#112	019-428
#50	019-403	#82	019-416	#115	019-429
#52	019-404	#85	019-417	#118	019-430
#55	019-405	#88	019-418	#120	019-431
#58	019-406	#90	019-419	#122	019-432
#60	019-407	#92	019-420	#125	019-433
#62	019-408	#95	019-421	#128	019-434
#65	019-409	#98	019-422	#130	019-435
#68	019-410	#100	019-423	#135	019-437
#70	019-411	#102	019-424	#140	019-439
#72	019-412	#105	019-425	#145	019-441
#75	019-413	#108	019-426	#150	019-443
#78	019-414	#110	019-427		

# KEIHIN Slow Jets (Pilot)

## CR Special Starter Jets (1001-108-XXX)

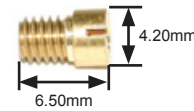

The starter jet adjusts the richness of the starter valve by metering the amount of fuel entering the float bowl.  
**Applications:** CR Special (CRS) 26 - 33mm & 35 - 39mm Carburetors.

Size	Order No.	Size	Order No.	Size	Order No.
#35	019-370	#50	019-373	#65	019-376
#40	019-371	#60	019-375	#70	019-377
#45	019-372				

## N424-52-XXX OEM FCR-MX Leak Jet

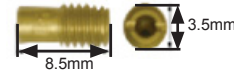

**Applications:** Powerjet for OEM PWK carburetor,  
**Kawasaki** (Power Jet) 4-stroke KX250F (03-10), KX450F (06-08), KLX450R Offroad (08-09), KX series PWK,  
**Suzuki** RM-Z250 (03-08), RM-Z450 (05-07),  
**Yamaha** WR/YZ250F (01-08), WR/YZ450 (06-08), YFZ450 ATV (04-07)

**These jets are used on OEM FCR-MX carburetors only.**

Size	Order No.	Size	Order No.	Size	Order No.
#35	019-750	#72	019-765	#108	019-779
#38	019-751	#75	019-766	#110	019-780
#40	019-752	#78	019-767	#112	019-781
#42	019-753	#80	019-768	#115	019-782
#45	019-754	#82	019-769	#118	019-783
#48	019-755	#85	019-770	#120	019-784
#50	019-756	#88	019-771	#122	019-785
#52	019-757	#90	019-772	#125	019-786
#55	019-758	#92	019-773	#128	019-787
#58	019-759	#95	019-774	#130	019-788
#60	019-760	#98	019-775	#132	019-789
#62	019-761	#100	019-776	#135	019-790
#65	019-762	#102	019-777	#138	019-791
#68	019-763	#105	019-778	#140	019-792
#70	019-764				

## FCR Slow Air Screw Set Conversion



The Slow Air Jet conversion set meters the air entering the slow speed circuit. Replaces the Slow Air Jet with an adjustable air screw. Turning in richens mixture, turning out leans mixture. Parts sold individually(each).

**Applications:** All Keihin FCR Horizontal and Downdraft Series carburetors, FCR28, 32, 33, 35, 37, 39, 41mm, **Kawasaki** KLX400R Offroad (2003), ZX750 ZX-7RR with Keihin FVKD (96-97), **Suzuki** DR-Z400 with FCR, **Yamaha** WR/YZ400/426 with FCR (98-01)

Description	Keihin No.	Order No.
Air Screw	1014-817-2000	021-230
Coil Spring for Air Screw	16052-KM4-0040	021-235

Slow Air Jet Size	Slow Air Screw Set Adjustment (turn out)	Slow Air Jet Size	Slow Air Screw Set Adjustment (turn out)
#45	1/4 turn out	#120	1-1/4
#55	3/8	#125	1-1/2
#65	1/2	#130	1-3/4
#75	5/8	#135	2
#85	3/4	#140	2-1/4
#95	7/8	#145	2-1/2
#100	1	#150	2-3/4
#110	1-1/8	#155	3

## Keihin Dealer Main Jet Kits



Genuine OEM 99101-393-XXX Round Main Jets.  
*Made in Japan.*

### Keihin Dealer Main Jet Kit, sizes #60 - #105.

**Order No. 019-995**

Kit Includes qt 4 of the following main jet sizes:  
#60, #62, #65, #68, #70, #72, #75, #78, #80, #82, #85,  
#88, #90, #92, #95, #98, #100, #102, #105.  
Total jets: 76 with storage box.

### Keihin Dealer Main Jet Kit, sizes #108 - #152.

**Order No. 019-996**

Kit Includes qt 4 of the following Main Jet sizes:  
#108, #110, #112, #115, #118, #120, #122, #125, #128,  
#130, #132, #135, #138, #140, #142, #145, #148, #150, #152.  
Total jets: 76 with storage box.

### Keihin Dealer Main Jet Kit, sizes #155 - #200.

**Order No. 019-997**

Kit Includes qt 4 of the following Main Jet sizes:  
#155, #158, #160, #162, #165, #170, #172, #175, #178,  
#180, #182, #185, #188, #190, #192, #195, #198, #200.  
Total jets: 72 with storage box.

## Keihin Dealer Jet Kit (Slow & Main Jets)



Genuine OEM 99107-357-XXX Main Jets and N424-21-XXX Slow Jets.  
*Made in Japan.*

### Keihin Dealer Jet Kit, sizes #120 - #180 Main Jets and sizes #40 - #65 Pilot Jets.

**Order No. 019-999**

Kit Includes qt 2 of the following jet sizes:  
**Main Jets:** #120, #122, #125, #128, #130, #132, #135,  
#150, #152, #155, #158, #160, #162, #165, #168, #170,  
#172, #175, #178, #180.  
**Pilot Jets:** #40, #42, #45, #48, #50, #52, #55, #58, #60,  
#62, #65. Total jets: 62 with storage box.

## 99101-393-XXX/99101-GHB-000

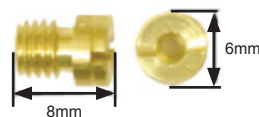

**Applications:** Starter Jet for Keihin FCR-MX, Main Air Jet for FCR's. Honda VB, VD, VE series carburetors, XR75 (74-75), XR650L Dual Sport, CB750 Nighthawk (91-04), CB750A (76-78), CB750C (80-82), CB750F Super Sport (79-82), CB750K (69-75), CB750K (77-82), CB750 SC Nighthawk, VFR750F Interceptor (1986), VFR750R (90-95), CBX1047cc (79-82), GL1100/A/I Goldwing (80-83), GL1500 Valkyrie, Kawasaki ATV, Street and Offroad models with CVK, ATV's with CVKR-D (V-Twin ATV), Suzuki ATV with CVK, Twin Peaks 700 with CVKR-D (V-Twin ATV).

Size	Order No.	Size	Order No.	Size	Order No.
#60	019-710	#108	019-181	#155	019-200
#62	019-711	#110	019-182	#158	019-201
#65	019-712	#112	019-183	#160	019-202
#68	019-713	#115	019-184	#162	019-203
#70	019-714	#118	019-185	#165	019-204
#72	019-715	#120	019-186	#168	019-205
#75	019-716	#122	019-187	#170	019-206
#78	019-717	#125	019-188	#172	019-207
#80	019-718	#128	019-189	#175	019-208
#82	019-719	#130	019-190	#178	019-209
#85	019-720	#132	019-191	#180	019-210
#88	019-721	#135	019-192	#182	019-211
#90	019-174	#138	019-193	#185	019-212
#92	019-175	#140	019-194	#188	019-213
#95	019-176	#142	019-195	#190	019-214
#98	019-177	#145	019-196	#192	019-215
#100	019-178	#148	019-197	#195	019-216
#102	019-179	#150	019-198	#198	019-217
#105	019-180	#152	019-199	#200	019-218

## 99101-357-XXX

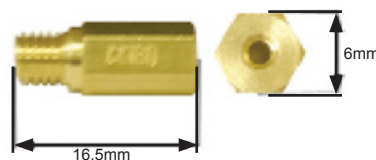

**Applications:** CR Special, all FCR's, FCR-MX, PE, PJ, PWK, PWM.

Size	Order No.	Size	Order No.	Size	Order No.
#80	019-101	#125	019-119	#170	019-135
#82	019-102	#128	019-120	#172	019-152
#85	019-103	#130	019-121	#175	019-136
#88	019-104	#132	019-122	#178	019-153
#90	019-105	#135	019-123	#180	019-137
#92	019-106	#138	019-124	#182	019-154
#95	019-107	#140	019-125	#185	019-138
#98	019-108	#142	019-126	#188	019-155
#100	019-109	#145	019-127	#190	019-139
#102	019-110	#148	019-128	#195	019-141
#105	019-111	#150	019-129	#200	019-143
#108	019-112	#152	019-130	#205	019-145
#110	019-113	#155	019-131	#210	019-147
#112	019-114	#158	019-132	#215	019-149
#115	019-115	#160	019-133	#220	019-702
#118	019-116	#162	019-150	#230	019-704
#120	019-117	#165	019-134		
#122	019-118	#168	019-151		

## Main Air Jet N424-14-XXX

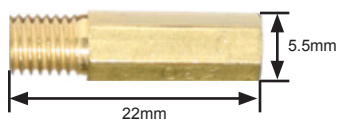

The Main Air Jet meters the air entering the needle jet holder. Use smaller number to richen.

Applications: Keihin CR Special (CRS) Carburetors.

Size	Order No.	Size	Order No.	Size	Order No.
#80	019-301	#140	019-309	#200	019-315
#90	019-303	#150	019-310	#210	019-316
#95	019-304	#160	019-311	#220	019-317
#100	019-305	#170	019-312	#230	019-318
#110	019-306	#180	019-313	#240	019-319
#120	019-307	#190	019-314	#250	019-320
#130	019-308				

## 99101-116-XXX

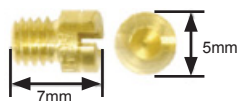

Applications: Keihin PB16, PB18 (small ATV), PC18, PC20, Honda ATC70 (78-85), TRX70, TRX90, XR75 (1976), Kawasaki KLX110, Suzuki DR-Z110, Main Air Jet for KTM 950 Adventurer.

Size	Order No.	Size	Order No.	Size	Order No.
#50	019-855	#72	019-864	#95	019-873
#52	019-856	#75	019-865	#98	019-874
#55	019-857	#78	019-866	#100	019-875
#58	019-858	#80	019-867	#105	019-876
#60	019-859	#82	019-868	#110	019-877
#62	019-860	#85	019-869	#115	019-878
#65	019-861	#88	019-870	#120	019-879
#68	019-862	#90	019-871		
#70	019-863	#92	019-872		

## 1001-806-XXX

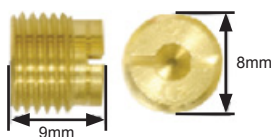

Applications: Harley-Davidson® (Non CV Type) BH production butterfly carburetors.

Size	Order No.	Size	Order No.	Size	Order No.
#90	019-239	#115	019-249	#150	019-263
#92	019-240	#118	019-250	#155	019-265
#95	019-241	#120	019-251	#160	019-267
#98	019-242	#125	019-253	#162	019-268
#100	019-243	#130	019-255	#165	019-269
#102	019-244	#135	019-257	#170	019-271
#105	019-245	#138	019-258	#175	019-273
#108	019-246	#140	019-259	#180	019-275
#110	019-247	#142	019-260	#185	019-277
#112	019-248	#145	019-261		

## N424-27-XXX

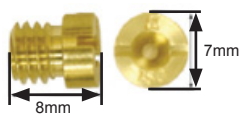

## N424-36-XXX Main Jets

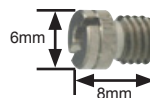

Nickel plated main jets to prevent corrosion.

Applications: Keihin CDK, CDKII 38 & 42 Watercraft Carburetors. OEM Kawasaki Jet-Ski with CDK carburetors.

Size	Order No.	Size	Order No.	Size	Order No.
#100	019-580	#132	019-593	#165	019-606
#102	019-581	#135	019-594	#168	019-607
#105	019-582	#138	019-595	#170	019-608
#108	019-583	#140	019-596	#172	019-609
#110	019-584	#142	019-597	#175	019-610
#112	019-585	#145	019-598	#180	019-612
#115	019-586	#148	019-599	#185	019-614
#118	019-587	#150	019-600	#190	019-615
#120	019-588	#152	019-601	#195	019-616
#122	019-589	#155	019-602	#200	019-617
#125	019-590	#158	019-603		
#128	019-591	#160	019-604		
#130	019-592	#162	019-605		

## Honda Primary Type Main Jet 99201-601-XXX (non genuine type)



Applications: Early model Honda CV carbs: CB/CL/SL350K, GL1000.

Size	Order No.	Size	Order No.	Size	Order No.
#60	026-010	#70	026-014	#88	026-018
#62	026-011	#72	026-015	#90	026-019
#65	026-012	#75	026-016	#92	026-020
#68	026-013	#82	026-017		

## Honda Secondary Type Main Jet 99202-601-XXX (non genuine type)



Applications: Early model Honda CV carbs: CB/CL350K, CB350/400F, CB500, CB550, GL1000, Kawasaki KZ400D/S, Yamaha TX500/XS500.

Size	Order No.	Size	Order No.	Size	Order No.
#68	026-043	#98	026-051	#125	026-057
#70	026-044	#100	026-052	#130	026-058
#72	026-045	#105	026-053	#135	026-059
#75	026-046	#110	026-054	#140	026-060
#78	026-047	#115	026-055	#150	026-062
#80	026-048	#120	026-056		

Applications: Harley-Davidson® CVH (CV Type) carburetor.

Size	Order No.	Size	Order No.	Size	Order No.
#150	019-562	#175	019-567	#200	019-572
#155	019-563	#180	019-568	#205	019-573
#160	019-564	#185	019-569	#210	019-574
#165	019-565	#190	019-570	#220	019-576
#170	019-566	#195	019-571		



## Ducati FCR Dual Kits

Kits include pre-jetted Keihin FCR carbs, K&N Air Filter (for stock air box), throttle, throttle cables and all necessary adapters.

Model	Year	Description	Order No.
750SS/900SS Dual	91-02	Keihin FCR-39 Kit	<b>016-720</b>
750SS/900SS Dual	91-02	Keihin FCR-41 Kit	<b>016-721</b>
M900 Monster Dual		Keihin FCR-39 Kit	<b>016-722</b>
M900 Monster Dual		Keihin FCR-41 Kit	<b>016-723</b>



## Harley-Davidson® Keihin Kits

Kits include pre-jetted Keihin FCR carb, air cleaner adapter and mounting hardware.

Model	Year	Description	Order No.
Big Twin	90-04	FCR-41 without Air Cleaner	<b>016-756</b>
Big Twin	90-04	FCR-41 with Air Cleaner 80 cubic	<b>016-755</b>
XL883 Sporster	90-04	FCR-39	<b>016-753</b>
XL1200 Sporster	90-04	FCR-39	<b>016-753</b>



## Ducati FCR Split Single Kits

Kit includes pre-jetted Keihin FCR carbs, throttle, cables, and velocity stacks. **Note-** 900SS/900M Split kits are available with two downdraft carburetor or one horizontal and one downdraft carburetor depending on manifold configuration. **Aftermarket manifolds required for Split kits.**

Model	Description	Order No.
M900 Monster, 900SS Split Single	Keihin FCR-39 Kit Two Downdraft 39mm	<b>016-746</b>
M900 Monster, 900SS Split Single	Keihin FCR-39 Kit 1 DD and 1 H 39mm	<b>016-746A</b>
M900 Monster, 900SS Split Single	Keihin FCR-41 Kit Two downdraft 41mm	<b>016-747</b>
M900 Monster, 900SS Split Single	Keihin FCR-41 Kit 1 DD and 1 H 41mm	<b>016-747A</b>



## Kawasaki EX250 Ninja

Kit includes pre-jetted Keihin CR31 Special dual carburetors, air box adapters, and intake adapters. **Note:** Specify year when ordering.

Model	Year	Description	Order No.
Kawasaki EX250 Ninja R		Keihin CR31 Kit	<b>016-3205</b>



## Moto-Guzzi 1100 Kit

Kit includes pre-jetted Keihin FCR41 carb, velocity stacks, throttle and throttle cables. **Note: Does not utilize stock airbox.**

Model	Year	Description	Order No.
1100 Sport Carb Kit	94-96	Keihin FCR41 Kit	<b>016-744</b>



## Norton Commando Kit

Kit includes pre-jetted Keihin FCR35 carbs, 2 K&N Filters, throttle and throttle cables. **Requires Amal Mk II Conversion Manifolds.**

Model	Description	Order No.
Commando 750/850	Keihin FCR35 Kit	016-860



## Triumph Bonneville CR Kit

Kit includes pre-jetted Keihin CR35 Special dual carburetors, velocity stacks, and intake adapters.

**Note:** Will fit stock air box if snorkel is removed.

Model	Year	Description	Order No.
Triumph Bonneville	01 on	Keihin CR35 Kit	016-3600



## Suzuki SV650 Kits

Kit includes pre-jetted Keihin FCR carbs, velocity stacks and throttle cables.

Model	Year	Description	Order No.
SV650/S	99-02	Keihin FCR39 Kit	016-762
SV650/S	99-02	Keihin FCR41 Kit	016-763



## Yamaha TDM/TRX850 Kit

Kit includes pre-jetted Keihin FCR carb, velocity stacks and throttle cables. **Use with Stock airbox.**

Model	Year	Description	Order No.
TDM850 Dual	all	Keihin FCR41 Kit	016-735



## Triumph Bonneville FCR Kit

Kit includes pre-jetted Keihin FCR39 carbs with TPS, K&N RC-2890, RC-2900 Air Filters and air cleaner adapters.

Model	Year	Description	Order No.
Bonneville/Thruxton	01 on	Keihin FCR39 Kit	016-877

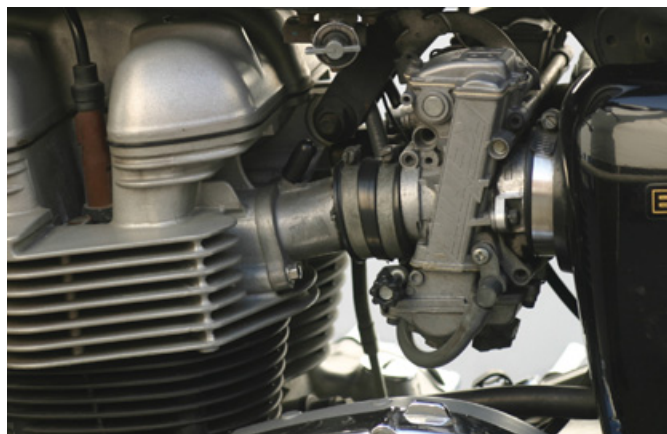



## Harley-Davidson® Kits

Kits include pre-jetted Mikuni VM carburetor, throttle cable, K&N Air Filter, Sudco/Mikuni Tuning Manual, manifolds, additional jets for fine tuning and all necessary adapters.

Model	Description		Order No.
Sportster**/Shovelhead	Mikuni VM38	HDS-101/38mm	<b>001-200</b>
Sportster**/Shovelhead	Mikuni VM44	HDS-101B/44mm	<b>001-202</b>
Knucklehead/Panhead	Mikuni VM38	HDS-102/38mm	<b>001-201</b>
Knucklehead/Panhead	Mikuni VM44	HDS-102B/44mm	<b>001-205</b>

\*\*Sportster 1984 and earlier models only

## Kawasaki H2-750 Kits

Kits include pre-jetted Mikuni TM Flat Slide carburetors, K&N RC-1250 Air Filters and rubber mounting flanges.

Description	Year	Order No.
Mikuni TM32 Kit	1972-1975	<b>001-239</b>
Mikuni TM34 Kit	1972-1975	<b>001-241</b>



## Honda CB/CL350 Kit

Kits include pre-jetted Mikuni VM Round Slide carburetors, K&N RC-1250 Air Filters and 2 into 1 throttle cable.

Description	Year	Order No.
Mikuni VM30 Kit	1968-1973	<b>001-247</b>

## Norton Commando 750/850 Kits

Kits include Mikuni VM pre-jetted carb, rubber flanges, manifolds, spare jets and Sudco/Mikuni Tuning Manual.

**Cables not included with kits. Order separately.**

**Note:** VM Roundslide carburetors may be upgraded to TM Flat Slide carburetors on many applications. Ask your Sudco sales rep. for details.

Description	Order No.
Mikuni VM32 Dual Kit	<b>001-250</b>
Mikuni VM34 Dual Kit	<b>001-251</b>
Mikuni VM34 Single Kit	<b>001-252</b>
Mikuni VM36 Single Kit	<b>001-253</b>
Mikuni VM38 Single Kit	<b>001-254</b>

Throttle Cable for VM34 Single Carb Kit	<b>007-575</b>
Throttle Cable for VM36, VM38 Single Carb Kit	<b>007-576</b>
Throttle Cable for VM32, VM34 Dual Carb Kits	<b>002-025</b>

**(some soldering required for 002-025)**



## Royal Enfield 500 Kits

Kits include Mikuni VM pre-jetted carb, rubber flange, manifold spacer plate, mounting bolts, throttle cable, K&N RU-0600 Air Filter, fuel lines and a Sudco/Mikuni Tuning Manual.

Description	Year	Order No.
Mikuni VM30 Kit	00 on	<b>001-265</b>
Mikuni VM32 Kit	00 on	<b>001-266</b>
Mikuni VM34 Kit	00 on	<b>001-237</b>

## Norton Atlas Kit

Kit includes Mikuni VM pre-jetted carb, rubber flange, manifold, spare jets and Sudco/Mikuni Tuning Manual.

Description	Order No.
VM34 Single Kit	<b>001-233</b>
Throttle Cable for VM34 Single Carb Kit	<b>007-575</b>

**Air Filter will not fit. Cables not included with kit. Order separately.**





## Triumph Bonneville VM Kits

Kits include Mikuni VM pre-jetted carbs, rubber flanges when applicable, manifolds, air filters, spare jets and Sudco/Mikuni Tuning Manual.

Description	Year	Order No.
Mikuni VM30 Kit	1964-mid 1968	001-278
Mikuni VM32 Kit	1964-mid 1968	001-279
Mikuni VM34 Kit	1964-mid 1968	001-280
Mikuni VM30 Kit	1969-mid 1972	001-275
Mikuni VM32 Kit	1969-mid 1972	001-276
Mikuni VM34 Kit	1969-mid 1972	001-277
Mikuni VM30 Kit	1973-1978	001-290
Mikuni VM32 Kit	1973-1978	001-291
Mikuni VM34 Kit	1973-1978	001-292

Throttle Cable only for VM30 -34 Kits **005-578**  
**Throttle Cable part number 007-578 requires 2 for junction box.**



## Triumph TR6/TR7 Single Kits

Kits include Mikuni VM pre-jetted carb, rubber flange, manifold, spare jets Sudco/Mikuni Tuning Manual and air filters.

Description	Year	Order No.
Mikuni VM30 Kit	1947-1981	001-293
Mikuni VM32 Kit	1947-1981	001-294
Mikuni VM34 Kit	1947-1981	001-295

Replacement Throttle Cable only for VM Kits **007-577**

## Yamaha XS650 Kit

Kit includes pre-jetted Mikuni VM34 carbs, rubber mounting flanges, spare jets, K&N RB-0610 Air Filter, throttle cable and Sudco/Mikuni Tuning Manual.

**Note: Removal or slight modifying of side covers required.**

Model	Year	Description	Order No.
XS650	70-79	VM34 Kit	001-235
		Replacement Throttle Cable only for VM34 Kit	021-960



## SI-1 Complete Fuel System Cleaner

SI-1's injector and valve detergent is a concentrated package of the most powerful high-temperature detergents available to clean gasoline fuel injectors or carburetors, intake valves and combustion chambers. and can clean injectors to nearly 100% efficiency in one treatment. The cleansing effect on injector deposits can raise fuel economy 12% or even greater depending on the condition of the injectors. SI-1 also contains detergents and a synthetic upper cylinder lubricant which will help clean pollution control valves and can reduce octane requirements by two numbers. SI-1 also protects the fuel system from rust. Sold in 15 fl. oz. bottle.

Order No. **900-870**



## Arctic Cat DVX 400 Kit

The 39mm FCR kit bolts right on to your stock intake manifold and airbox. A push/pull throttle assembly must be used (supplied with kit). This is a great kit for stock to mild motors for trail, wood, and mx. The 41mm FCR kit is also a bolt-on and is perfect for highly modified big bore engines to wide open desert and dune riding.

Model	Description	Order No.
DVX400 Carb Kit	Keihin FCR39	<b>016-855</b>
DVX400 Carb Kit	Keihin FCR41	<b>016-856</b>



## Honda XR600R Kit

Kit includes pre-jetted FCR41 carb, adapter and push/pull throttle cables. Bolts on to your stock air box and intake manifolds. The 41mm kit is well suited to all around condition, trail riding, woods and mx with stock and modified motors.

Model	Year	Description	Order No.
XR600R Carb Kit	89-00	Keihin FCR41 Kit	<b>016-730</b>



## Honda TRX400EX Kit

Kit includes pre-jetted Keihin FCR carb, push/pull throttle and throttle cables. Bolts on to your stock air box and intake manifolds. The 39mm kit is well suited to all around condition, trail riding, woods and mx with stock to mild motors. The 41mm carb is best with big, highly modified engines and used such as desert racing, duning, and sand drags.

Model	Year	Description	Order No.
TRX400EX Carb Kit	99 on	Keihin FCR39 Kit	<b>016-759</b>
TRX400EX Carb Kit	99 on	Keihin FCR41 Kit	<b>016-761</b>



## Honda XR650R Kit

Kit includes pre-jetted Keihin FCR carb, push/pull throttle and throttle cables. Bolts on to your stock air box and intake manifolds. The 41mm kit is well suited to all around condition, trail riding, woods and mx with stock and modified motors.

Model	Year	Description	Order No.
XR650R Carb Kit (no air filter)	00-07	Keihin FCR41 Kit	<b>016-765</b>

See page 159 for Mikuni TM kit.



## Honda XR650L Kit

Kit includes pre-jetted Keihin FCR41 carb, push/pull throttle and throttle cables. Bolts on to your stock air box and intake manifolds. The 41mm kit is well suited to all around condition, trail riding, woods and stock and modified motors.

Model	Year	Description	Order No.
XR650L w/oChoke	93-07	Keihin FCR41	<b>016-749</b>
XR650L w/Choke	93-07	Keihin FCR41	<b>016-749A</b>



## Husaberg FE501 Kit

Kit includes pre-jetted Keihin FCR41 carb with choke. Bolts on to your stock intake manifold and airbox.

Model	Description	Order No.
FE501 Carb Kit	Keihin FCR41	<b>016-872</b>



## Husaberg FS650 Kit

Kit includes pre-jetted Keihin FCR41 carb with choke. Bolts on to your stock intake manifold and airbox.

Model	Description	Order No.
FS650 Carb Kit with choke	Keihin FCR41	016-873



## Kawasaki KFX400 Kit

This 39mm FCR kit bolts right on to your stock intake manifold and airbox. A push/pull throttle assembly must be used (supplied with kit). This is a great kit for stock to mild motors for trail, wood, and mx. The 41mm FCR kit is also a bolt-on and is perfect for highly modified big bore engines for wide open desert and dune riding.

Model	Description	Order No.
KFX400 Carb Kit	Keihin FCR39	016-855
KFX400 Carb Kit	Keihin FCR41	016-856



## Kawasaki KLX400 Kit

The 39mm FCR KLX400 kit bolts right on to your stock intake manifold and airbox. A push/pull throttle assembly must be used (supplied with kit). This is a great kit for stock to mild motors for trail, wood, and mx.

Model	Year	Description	Order No.
KLX400 Carb Kit	2003	Keihin FCR39	016-863
KLX400 Carb Kit with choke	2003	Keihin FCR39	016-864



## Kawasaki KLX650 Kit

Kit includes pre-jetted Keihin FCR41 carb. Use the stock throttle and choke cables. Bolts on to your stock intake manifold and air box.

Model	Year	Description	Order No.
KLX650 Carb Kit	93-96	Keihin FCR41	016-868



## KTM400 RXC & LC4 Kit

Kit includes pre-jetted Keihin FCR39 carb and push/pull throttle cables. Kit 016-740 uses stock throttle housing. A Motion Pro push/pull throttle is supplied with kit 016-740A. Bolts on to your stock air box and intake manifolds.

Model	Description	Order No.
KTM400 RXC & LC4 Carb Kit	Keihin FCR39	016-740
Use with stock throttle housing	(to mid 2000 only)	
KTM400 RXC & LC4 Carb Kit	Keihin FCR39	016-740A
Includes a Motion Pro Throttle	(to mid 2000-2006)	



## KTM950 Adventurer Kit

Kits include pre-jetted Keihin FCR carb, adapters, push/pull throttle cables. Bolts on to your stock intake manifolds.

Model	Year	Description	Order No.
KTM950 Carb Kit	03-07	Keihin FCR39	016-875
KTM950 Carb Kit	03-07	Keihin FCR41	016-876



## KTM620/640 Kit

Kit includes pre-jetted Keihin FCR39 carb and push/pull throttle cables. Bolt-on kits that run the way KTM engineers intended. Easier starting and smooth glitch free POWER.

Model	Description	Order No.
KTM620/640 Carb Kit	Keihin FCR41 (1994 to mid 2000 only)	<b>016-739</b>
KTM620/640 Carb Kit	Keihin FCR41 (mid 2000-present)	<b>016-739A</b>



## Suzuki LT-Z400 Kit

The 39mm FCR LTZ400 kit bolts right on to your stock intake manifold and airbox. A push/pull throttle assembly must be used (supplied with kit). This is a great kit for stock to mild motors for trail, wood, and mx. The 41mm FCR kit is also a bolt-on and is perfect for highly modified big bore engines for wide open desert and dune riding.

Model	Description	Order No.
LT-Z400 Carb Kit	Keihin FCR39	<b>016-855</b>
LT-Z400 Carb Kit	Keihin FCR41	<b>016-856</b>



## Yamaha YXR660 Rhino Kit

Kit includes FCR41 pre-jetted carburetor and throttle cable. The FCR41 kit for the Rhino 660 works well with stock or slightly modified motor. Improved throttle response and acceleration through the entire powerband.

Model	Description	Order No.
YXR660 Carb Kit	FCR41	<b>016-866</b>

See page 159 for Mikuni HSR kit.



## Suzuki DR-Z400

The 39mm FCR kit bolts right on to your stock intake manifold and airbox. A push/ pull throttle assembly must be used (supplied with kit). This is a great kit for stock to mild motors for trail, wood, and mx. Will fit 2000-2007 DRZ400S Y, K1-K6, 2004-2006 DRZ400E K4-K6 (Calif. Models only), 2005-2006 DRZ400SM K5-K6. Also fits Kawasaki KLX400 Dual Sport (2003).

Model	Description	Order No.
DR-Z400 Carb Kit	Keihin FCR39	<b>016-863</b>
DR-Z400 Carb Kit with choke	Keihin FCR39	<b>016-864</b>



## Yamaha YFM660 Raptor Kit

Simple bolt-on horsepower. FCR35mm for stock to mild engines, and FCR39 for modified engines. Everything is included for a simple installation. Stock and some aftermarket exhaust may interfere with the accelerator pump chamber. This kit retains your stock airbox.

Model	Description	Order No.
YFM660 Raptor Carb Kit	FCR35	<b>016-850</b>
YFM660 Raptor Carb Kit	FCR39	<b>016-851</b>



## Yamaha YFS200 Blaster Kit

This kit really wakes up modified Blasters. It bolt-on right onto the stock intake manifold and airbox. Not recommended for stock engines. Available for stock thumb or with a twist throttle and cable.

Model	Description	Order No.
YFS200 Carb Kit for Twist Throttle	Keihin PWK33	<b>016-251</b>
YFS200 Carb Kit for Thumb Throttle	Keihin PWK33	<b>016-252</b>



## Honda XR400R Kit

Kit includes pre-jetted Mikuni TM36 pumper carb, push/pull throttle cables, and Sudco/Mikuni Tuning Manual. Everything is included to mount this carb to your bike. This kit is well suited for stock and mildly modified motors.

Model	Description	Order No.
XR400R Carb Kit	Mikuni TM36 Kit	001-240



## Honda XR650R Kit

Kit includes pre-jetted Mikuni TM40 pumper carb, push/pull throttle cables, and Sudco/Mikuni Tuning Manual. Bolts on to your stock air box and intake manifolds.

Model	Description	Order No.
XR650R Carb Kit	Mikuni TM40 Kit	001-238

See page 156 for Keihin FCR kit.



## Yamaha YFM350 Warrior Kit

Kit includes pre-jetted Mikuni TM36 Pumper carb, Rubber Flange, airbox adapter, push/pull throttle cable, push/pull throttle, and Sudco/Mikuni Tuning Manual.

Model	Description	Order No.
YFM350 Warrior Carb Kit	Mikuni TM36 Pumper Carb	001-297



## Yamaha YXR660 Rhino Kit

Kit includes HSR45 pre-jetted carburetor, throttle cable, and Sudco/Mikuni Tuning Manual. Improved throttle response and acceleration through the entire powerband.

Model	Description	Order No.
YXR660 Carb Kit	Mikuni HSR45 Kit	001-298

See page 158 for Keihin FCR kit.



## Mikuni RS Smoothbore Carburetors

Designed for in-line four cylinder performance motorcycles, the Mikuni RS Series Radial Flat Slide Carburetors offer superior horsepower gains with their maximum flowing smoothbore induction tract and radial flat slide design. An adjustable accelerator pump system helps to provide instant throttle response, particularly in the lower RPM range. The RS Series Carburetors feature a compact design which is 25% lighter than other performance Carburetors and uses readily available Mikuni jets. Available sizes : RS34, RS36, RS38 and RS40mm.

### Features of the RS Series Carburetors

- Adjustable Pump Adjust Screws. Sets ON and OFF operation of accelerator pump in relation to throttle slide position.
- Throttle Return Spring. A choice of positioning pegs allow adjustment of spring tension.
- Idle Adjustment Screw. Controls engine idle speed.
- Adjustment Accelerator Pump. Squirts fuel into carburetor venturi when throttle is opened to improve engine response.
- Starter System. Provides fuel enrichment for cold engine starting.
- Adjustable Pump Spray Nozzle. Shoots fuel directly into the intake tract for immediate engine response.

### Features of the RS Series Carburetors

- Jet Needle Clip. Easy adjustment feature for quick adjustment.
- Flat Throttle Valve Design. Provides the strongest signal for precise and instantaneous throttle response.
- Float Bowl Vent. Allows atmospheric pressure into float bowl for fuel flow.
- Smooth Throttle Bore/Venturi. Produces the optimum air and fuel mixture flow at all RPM's.
- Genuine Mikuni Jets and Tuning Components. Provides for precise fuel metering.
- Pilot Air Jet. Use in conjunction with the Pilot Fuel Screw for tuning of mixture at idle to 1/4 throttle.

## Ordering RS Smoothbore Carburetors

Available in 34, 36, 38 and 40mm bore sizes with different carb spacing for particular bike applications and with different jetting to match engine modifications. Please see application chart listing on next page. **Note:** These are guidelines only. Specifications are subject to change.

### Center Bell Crank

Mikuni No.	Order No.
RS34-D21	001-319
RS36-D3	001-320
RS36-D8	001-321
RS38-D19	001-325
RS38-D35	001-326
RS40-D1	001-330
RS40-D12	001-331

### Left Side Bell Crank

Mikuni No.	Order No.
RS36-D9	001-322
RS38-D29	001-327
RS40-D7	001-332

**IMPORTANT:** Mikuni RS Carburetors are legal in California ONLY FOR RACING VEHICLES WHICH MAY NEVER BE USED UPON A PUBLIC STREET OR HIGHWAY. In other locations check for similar laws which may apply.

## Standard Jetting Specifications Center Bell Crank

Mikuni No.	Application * (General)	Carb Spacing (Throttle Shaft No.) A-B-C	Spigot (O.D.) MM	Main Jet N100.604	Jet Needle (J8-) (Clip Pos.)	Needle Jet #568 (784-13002)	Pilot Jet (VM28/486)	Pilot Screw (Turns)
RS34-D21	Suz GSX600F Katana (1988)	77-93-77	40	115	9DZH01*	P-4	17.5	1/4-1/2
	Suz GSX-R750 (88-92)	(700-17011)		115	(-3)			
	Suz GS750			115				
	Kaw KZ750							
RS36-D8	Kaw ZX900A Ninja (84-86)	77-85-77	42	130	9DZH01*	P-4	17.5	1/4-1/2
	Kaw ZX1000A Ninja (86-87)	(700-17011)		130	(-3)			
	Yam FJ1100 (84-85)			130				
	Yam FJ1200 (86-92)			130				
RS36-D3	Kaw KZ1000J/K/M/R (81-83)	77-93-77	42	120	9DZH01*	P-4	17.5	1/4-1/2
	Kaw KZ1100A/D (81-85)	(700-17011)		120	(-3)			
	Suz GSX600F Katana (1988)			120				
	Suz GS1000/1100/1150			120				
	Suz GSX-R750/1100 Air Cooled		120					
RS38-D19	Kaw KZ1000J/K/M/R (81-83)	77-93-77	42	135	9CHY03*	Y-6	17.5	1/4-1/2
	Kaw KZ1100A/D (81-85)	(700-17011)		135	(-3)			
	Suz GSX600F Katana (1988)			135				
	Suz GS1000/1100/1150			135				
RS38-D35	Kaw ZX900A Ninja (84-86)	77-85-77	42	130	9CHY03*	Y-6	17.5	1/4-1/2
	Kaw ZX1000A Ninja (86-87)	(700-17011)		130	(-3)			
	Yam FJ1100 (84-85)			130				
	Yam FJ1200 (86-92)							
RS40-D12 For Race use on models listed	Kaw ZX900A Ninja (84-86)	77-85-77	44	140	9CHY03*	Y-6	17.5	1/4-1/2
	Kaw ZX1000A Ninja (86-87)	(700-17011)		140	(-2)			
	Yam FJ1100 (84-85)			140				
	Yam FJ1200 (86-92)			140				
RS40-D1 For Race use on models listed	Kaw KZ1000J/K/M/R (81-83)	77-93-77	44	140	9CHY03*	Y-6	17.5	1/4-1/2
	Kaw KZ1100A/D (81-85)	(700-17011)		140	(-3)			
	Suz GS1000/1100/1150			140				
	Suz GSX-R750/1100 Air Cooled		140					

## Standard Jetting Specifications Left Bell Crank Uses left side throttle linkage.

** RS36-D9	Kaw KZ1000J/K/M/R (81-83)	77-93-77	42	120	9DZH01*	P-4	17.5	1/4-1/2
	Kaw KZ1100A/D (81-85)	(700-17012)		120	(-3)			
	Suz GSX600F Katana (1988)			120				
	Suz GS1000/1100/1150			120				
** RS38-D29	Kaw KZ1000J/K/M/R (81-83)	77-93-77	42	135	9CHY03*	Y-6	17.5	1/4-1/2
	Kaw KZ1100A/D (81-85)	(700-17012)		135	(-3)			
	Suz GS1000/1100/1150			135				
	Suz GSX-R750/1100 Air Cooled		135					
** RS40-D7 For Race use on models listed	Kaw KZ1000J/K/M/R (81-83)	77-93-77	44	140	9CHY03*	Y-6	17.5	1/4-1/2
	Kaw KZ1100A/D (81-85)	(700-17012)		140	(-3)			
	Suz GS1000/1100/1150			140				
	Suz GSX-R750/1100 Air Cooled		140					

## RS Series Notes

Mikuni No. (part number) in application chart above denotes size in millimeters. RS34-D21 = RS34.

\*\* Uses left side throttle linkage.

• Applications (General) - These are guidelines only. Specifications are subject to change.

• RS34 and RS36 Carburetors may use Jet Needle #9DZH05.

• RS38 and RS40 Carburetors may use Jet Needle #9CHY10.

Pre Kawasaki KZ1000J models require qt 4 mounting flanges.

Order No. 005-866, Qt 4 set.

### Carburetor Spacing (mm):

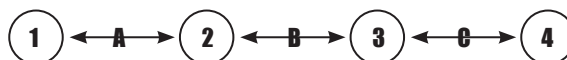

# MIKUNI RS Smoothbore Exploded View

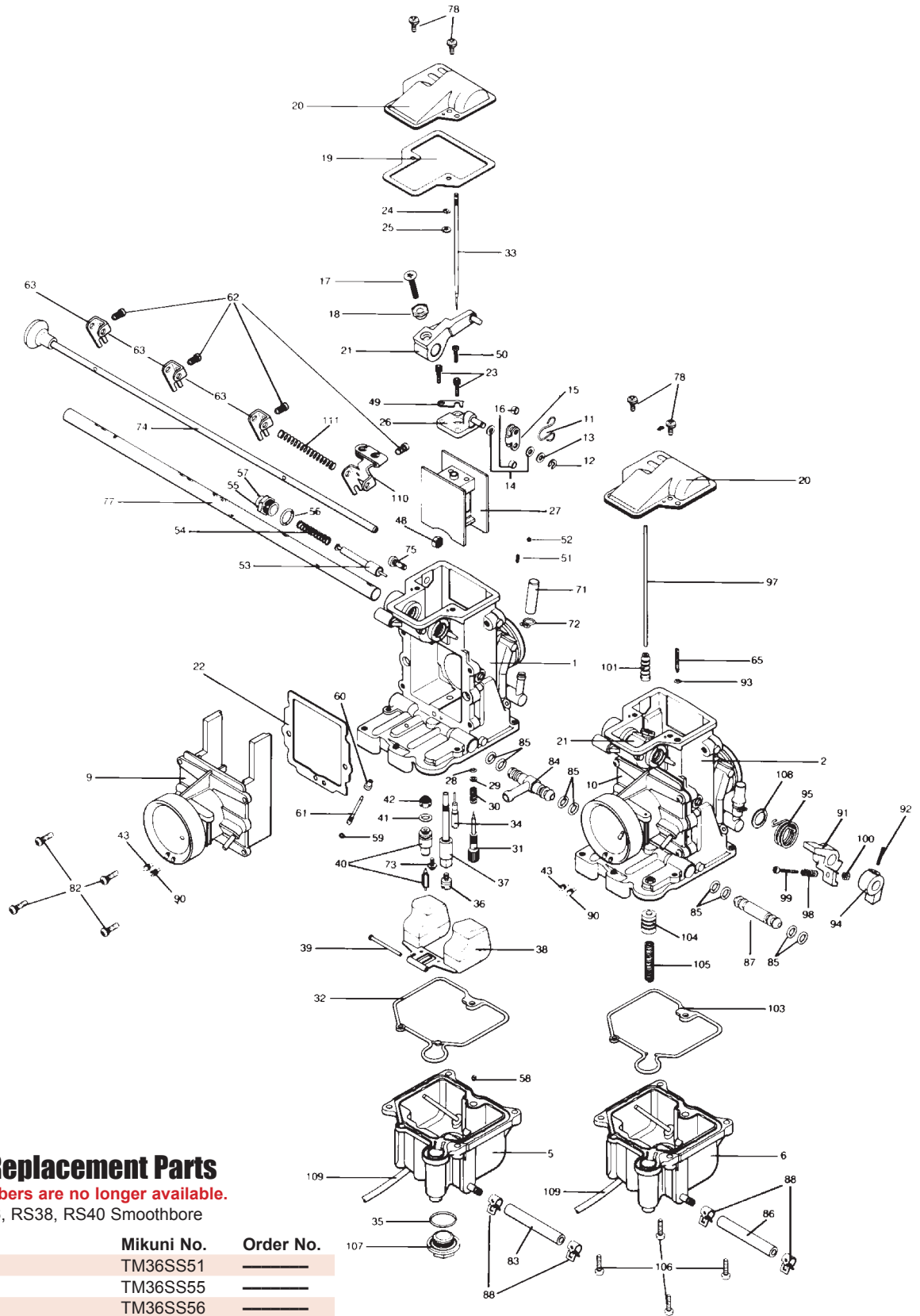

**Float Height**  
**17mm**

## RS Smoothbore Replacement Parts

• Lined through part numbers are no longer available.

Applications: RS34, RS36, RS38, RS40 Smoothbore

No.	Description	Mikuni No.	Order No.
1.	Mixing Body	TM36SS51	_____
2.	Mixing Body	TM36SS55	_____
3.	Mixing Body	TM36SS56	_____
4.	Mixing Body	TM36SS57	_____
5.	Float Chamber Body	TM36/69	_____
6.	Float Chamber Body	TM36/71	_____
7.	Float Chamber Body	TM36/73	_____

**IMPORTANT:** Mikuni RS Carburetors are legal in California only for RACING vehicles which may never be used upon a public street or highway. In other locations check for similar laws which may apply.



## RS Smoothbore Replacement Parts

• Lined through part numbers are no longer available.

No.	Description	Mikuni No.	Order No.
8.	Float Chamber Body	TM36/75	_____
9.	Air Funnel Body	TM36/27A	_____
10.	Air Funnel Body	TM36/27B	_____
11.	Clip, T.V. Lever	TM27/05A	_____
12.	E-Ring, T.V. Lever	BSW28/70	<b>002-355</b>
13.	Washer, T.V. Lever	M10/56	<b>002-632</b>
14.	Packing, T.V. Lever	B401/10	<b>002-629</b>
15.	Plate, T.V. Lever	TM27/04	_____
16.	Ring, T.V. Lever	TM29/65	_____
17.	Screw, Sync. Lock	C5=0518	<b>007-117</b>
18.	Ring, Sync. Adjust	TM36/06	<b>007-118</b>
19.	Gasket, Top Cover	TM36/39	<b>007-119</b>
20.	Top Cover, Carb	TM36/59	_____
21.	Lever Ass'y., T.V. #1 & #2	TM36/51	_____
22.	Gasket, A/Funnel	TM36/42	<b>007-658</b>
23.	Screw, 2.5mm Allen	739-13001	<b>007-123</b>
24A.	E-Ring, RS34, RS36 Needle	VM20/369	<b>002-083</b>
24B.	E-Ring, RS38, RS40 Needle	BS32/126	<b>002-455</b>
25A.	Washer, RS34, RS36 Needle Clip	VM26/315	<b>007-124</b>
25B.	Washer, RS38, RS40 Needle Clip	826-03002	<b>007-267</b>
26.	Connector Plate, T.V.	TM36/54	_____
27A.	Throttle Valve 2.0, RS34, RS36	<b>Mikuni only</b>	_____
27B.	Throttle Valve 2.0, RS38, RS40	<b>Mikuni only</b>	_____
28.	O-Ring, Pilot Fuel Screw	N133.037	<b>002-858</b>
29.	Washer, Pilot Fuel Screw	VM12/33	<b>002-856</b>
30.	Spring, Pilot Fuel	N133.206	<b>007-137</b>
31.	Screw, Pilot Fuel	604-26003	<b>007-138</b>
32.	O-Ring, F.C.B. #1-3-4	616-94020	<b>007-140</b>
33.	Jet Needle	9 Series	<b>Pg.164</b>
34.	Pilot Jet	VM28/486	<b>Pg.212</b>
35.	O-Ring, Float Bowl Drain Plug	VM28/254	<b>002-531</b>
36.	Main Jet	N100.604	<b>Pg.214</b>
37.	Needle Jet #568 Series	784-13002	<b>Pg.207</b>
38.	Float Assembly	859-32011	<b>007-141</b>
39.	Pin, Float	VM30/160	<b>002-605</b>
40.	Needle Valve Assembly	N149.040	<b>Pg.164</b>
41.	O-Ring, Needle Valve	KV/10	<b>002-709</b>
42.	Filter, Needle Valve	VM18/233	<b>002-606</b>
43.	Main Air Jet (Plugged)	BS30/97	<b>002-149</b>
44.	Screw, Crank Bracket	C8=0512	_____
45.	Lever Assembly, T.V. #3 Carb	TM36/57	_____
46.	Screw, Lever Lock	C5=0514	<b>007-625</b>

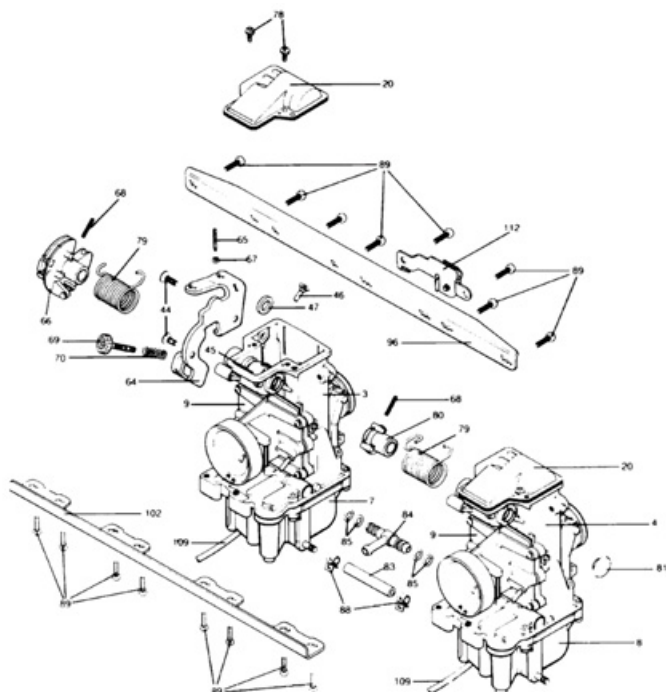

No.	Description	Mikuni No.	Order No.
47.	Packing, Shaft	VM28/174	_____
48.	Hexagon, Locknut	VM18/267	_____
49.	Plate, Needle Retainer	TM36/12	_____
50.	Screw, T.V. Plate	C2-0310	_____
51.	Spring, Starter Shaft	B21/29	<b>007-155</b>
52.	Ball, Starter Shaft	B21/18	<b>007-156</b>
53.	Plunger, Starter	N151.038	<b>007-747</b>
54.	Spring, Starter	VM16/42	<b>002-671</b>
55.	Guide Holder, Starter	640-12002	_____
56.	O-Ring, Starter	N138.198	<b>007-160</b>
57.	Cap, Starter	N106.211	_____
58.	Starter Jet	VM17/1002	<b>Pg.213</b>
59.	O-Ring, A/P Nozzle	N124.063	<b>007-163</b>
60.	Plug, A/P Nozzle	TM29/14	<b>007-164</b>
61.	Pump, Nozzle (STD)	TM36/43-03 (45)	<b>007-165</b>
		TM36-43-05 (55)	<b>007-166</b>
		TM36-43-08 (70)	<b>007-167</b>
62.	Screw, Start Bracket	N158.052	<b>002-659</b>
63.	Lever, Start Shaft	N178.656	_____
64.	Bracket, Bell Crank	TM36/37D	_____
65.	Adjuster Screw, A/P	TM36/48A	<b>007-168</b>
66.	Lever Assembly, Bell Crank	TM36/31	_____
67.	Hexagon Nut, A/P	N2-03-B	_____
68.	Pin, Bell Crank	N138.019	<b>007-171</b>
69.	Adjuster, Idle	739-55003	<b>007-490</b>
70.	Spring, Idle Adjuster	N110.209	<b>002-655</b>
71.	Cap, Vacuum Fitting	N148.013	<b>002-646</b>
72.	Spring Clip, Vacuum Fitting	BVK28/128	_____
73.	Screw, Needle Valve Holder	VM13/216	<b>007-174</b>
74.	Shaft Assembly, Starter	TM36/34A	_____
75.	Pan Head Screw	C2=0508-B	<b>002-648</b>
76.	Flat Head Screw	C5=0514	<b>007-625</b>
77A.	Shaft, Throttle B/C #3	700-17011	<b>002-904</b>
77B.	Shaft, Throttle B/C #1	700-17012	<b>002-905</b>
77C.	Shaft, Throttle B/C #3	700-17013	<b>002-906</b>
78.	Screw, Top Cover	CW2=0408	<b>007-175</b>
79.	Spring, Throttle Return	TM36/46A	<b>007-204</b>
80.	Lever, Throttle Return Spring	TM36/33	_____
81.	Cap, Shaft End	TM33/36A	_____
82.	Screw, Air Funnel	VM38/133B	<b>002-749</b>
83.	Hose, Fuel Connect	888-44003	<b>007-180</b>
84.	Inlet, Fuel "T"	791-23018	_____
85.	O-Ring, Fuel Joint	616-23002	<b>007-182</b>
86.	Hose, A/P Fuel	888-4404	_____
87.	Joint, Fuel	792-20014	<b>007-184</b>
87A.	Joint, Fuel	792-20013	<b>007-183</b>
	For RS36-D3, RS38-D19, RS40-D1		
88.	Clip, Fuel Hose	E100729-BB	_____
89.	Screw, Bracket	C2=0512-B	<b>002-628</b>
90.	Pilot Air Jet	BS30/97-0.8	<b>Pg.213</b>
91.	Lever, A/Pump	TM36/17	<b>007-292</b>
92.	Pin, A/Pump Locate	BN38/43	<b>007-617</b>
93.	O-Ring, A/Pump	B30-205	<b>007-188</b>
94.	Lever, A/Pump	TM36/18	<b>007-189</b>
95.	Spring, A/Pump	TM36/45	<b>007-190</b>
96.	Plate, Top Bracket	TM36/35	_____
97.	Rod, A/Pump	TM36/44	<b>007-192</b>
98.	Spring, A/Pump Adjust	M12F/46A	<b>002-181</b>
99.	Screw, A/Pump Adjust	MC-0316-B	<b>007-193</b>
100.	Hexagon Nut, A/Pump Adjust	N3=03-B	<b>007-194</b>
101.	Cap, A/Pump Rubber	TM36/64	<b>007-195</b>
102.	Plate, Lower Bracket	TM36/36	_____
103.	O-Ring, F.C.B. A/Pump	616-94021	<b>007-197</b>
104.	Plunger, A/Pump (12mm)	TM36/60A	<b>007-198</b>
105.	Spring, A/Pump (12mm)	VM14SC13/89	<b>007-200</b>
106.	Screw, Float Bowl	C2=0412-B	<b>007-201</b>
107.	Plug, Float Bowl Drain	TM32/41	<b>007-646</b>
108.	Ring, A/Pump Spring	E204.040	_____
109.	Hose	888-23026	<b>007-608</b>
110.	Lever, Starter Cable	TM36/63	<b>007-205</b>
111.	Spring, Bracket	730-06027	<b>007-206</b>
112.	Bracket, Cable	TM36/61	<b>007-207</b>



## Mikuni Methanol Conversion Kit

The Mikuni Methanol kit includes all necessary components, such as main jets, jet needles, needle jets, o-rings, needles valves, etc. to convert your RS38 or RS40 to methanol. Sold as a Kit.

**Note: Requires experienced tuner or technician familiar with re-jetting for methanol usage.**

Mikuni No.	Order No.
KRS-005	002-990

## K&N Air Filter for RS Series

Chrome and Rubber end cap K&N filters for Mikuni RS series. Sold each.

K&N No.	Order No.
RC-0981 with Chrome End Cap	005-121
RU-0981 with Rubber End Cap	005-744



## Needle Valve Assembly

**No.40 in exploded view on page 162.**

GENUINE Mikuni Needle Valve Assembly include needle valve and needle valve seat. Applications: RS34, RS36, RS38 & RS40

**(O-Ring for Needle Valve Seat not included)**

Size	Description	Mikuni No.	Order No.
(2.0)	Needle Valve & Needle Seat	N149.040	007-143
(2.5)	Needle Valve & Needle Seat	N149.040	007-144
(2.8)	Needle Valve & Needle Seat (Std)	N149.040	007-145
	<b>(007-145 is Std on all RS Series)</b>		
	O-Ring for Needle Valve Seat	KV-10	002-709
	Filter for Needle Valve Seat	VM18/233	002-606

## Velocity Stacks

Velocity stacks improve the air flow into the Carburetors to increase induction efficiency and increase horsepower on racing engines where air filters are not required. Fits all Mikuni RS series Carburetors and other Carburetors with 55mm O.D. intake bells. Choose length depending on chassis clearance and desired tuning characteristics (short length-broad high RPM power; medium length-mid RPM power; long length-low RPM power); Sold set/4.

Length	Mikuni No.	Order No.
15mm	KRS-007	005-253
30mm	KRS-002	005-250
50mm	KRS-003	005-251
70mm	KRS-004	005-252



## Sudco Intake Carb Holders

These carb holders are needed when mounting RS Smoothbore carburetors to early model KZ1000. (pre 1981)

Sold set of 4. **Made in Japan.**

Order No. **005-866**

## Jet Needles

**No.33 in exploded view on page 164.**

**Applications: RS34, RS36 Smoothbore**

Jet Needle	Length	Leaner	Order No.
9DZH01 (Std)	2.50		007-035
9DZH03	2.49		007-037
9DZH04	2.48	Richer	007-038

**Applications: RS38, RS40 Smoothbore**

Jet Needle	Length	Leaner	Order No.
9CHY03 (Std)	2.99		007-020
9CHY05	2.98		007-022
9CHY06	2.97	Richer	007-023



005-230

## Motion Pro Push/Pull Throttle Assembly

A push/pull throttle is required with the use of all Mikuni Racing Carburetors to assure the positive closing of the carburetor throttle slides against the high vacuum pressures encountered in racing engines. This push/pull throttle assembly includes a twist throttle assembly, push and pull cables with adjusters. Sold each.

Order No. **005-230**

Replacement Parts for Push/Pull Throttle Assembly

Description	Order No.
Pull Throttle Cable	<b>005-230A</b>
Push Throttle Cable	<b>005-230B</b>
Throttle Only	<b>005-230C</b>
Throttle Tube	<b>005-230D</b>



## Mikuni Pocket Tuner

A handy pocket-size calculator which can be used to determine required jetting changes in Mikuni Carburetors due to climate and temperature changes. The Pocket Tuner is applicable to both single and multi-carburetor applications on two-stroke and four-stroke engines. It also has a guide for determining rich or lean carburetor conditions. Sold each.

Order No. **002-430**



## Sudco Mikuni Carb Tool Kit

This handy little tool kit includes a multi-purpose wrench with ruler markings, screwdriver with assorted blades and sockets. Sold as a set.

Order No. **002-045**



## Sudco Mikuni Tuning Manual

This 92 page manual includes exploded parts views, parts listings and optional parts. Guides you through tuning and trouble shooting for the popular lines of Mikuni Carburetors. The definite reference for Mikuni Carburetors and a must for any do-it-yourself type. Sold each.

Order No. **002-999**

## Brass T-Fittings Sold each.

Description	Mfg. No.	Order No.
1/4" Brass Fuel T	44555K138	<b>009-100</b>
.17" Brass Fuel T	44555K137	<b>009-101</b>
3/8" Brass Fuel T	44555K139	<b>009-102</b>



009-102

009-100

# MIKUNI VM29 Smoothbore Exploded View

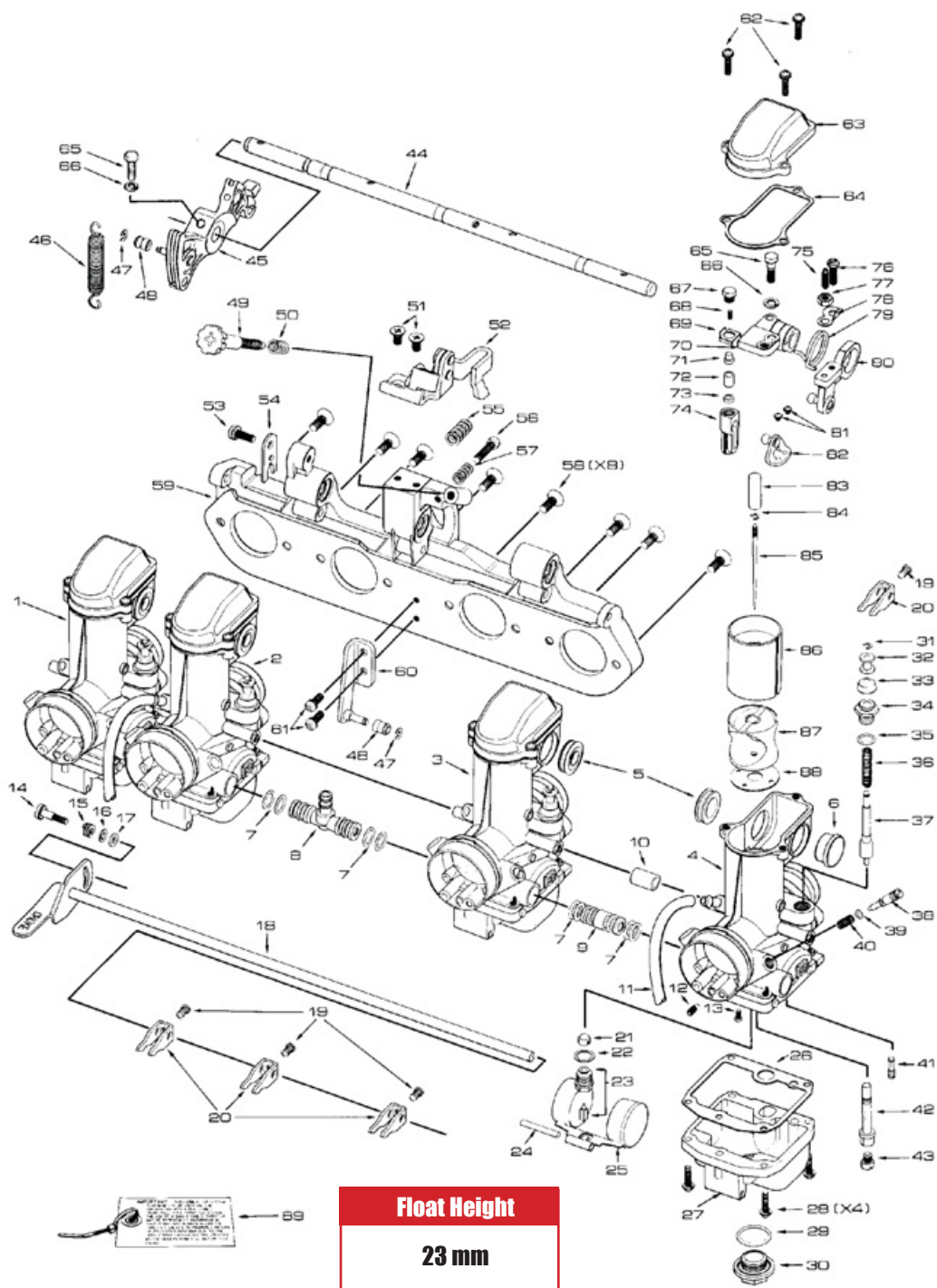

## Standard Jetting Specifications VM29 Smoothbore

Application	Carb Model	Main Jet N100.604	Air Jet BS30/97	Pilot Jet VM22/210	Jet Needle	Needle Jet #261 Series	Float Height	Throttle Valve VM29/15
Honda CB750 (SOHC) -1978	VM29-A2	#115	.9	#17.5	#5DL31-3	0-8	23mm	1.5
Kawasaki KZ650 (77-79)	VM29-A7	#120	.9	#25	#5DL31-3	0-6	23mm	1.5
Kawasaki KZ900 (76-77)	VM29-A7	#120	.9	#25	#5DL31-3	0-6	23mm	1.5
Kawasaki KZ1000 (77-80)	VM29-A7	#120	.9	#25	#5DL31-3	0-6	23mm	1.5
Suzuki GS750 2-Valve (77-79)	VM29-A12	#115	.9	#25	#5DL31-3	0-6	23mm	2.0
Suzuki GS1000 2-Valve (78-79)	VM29-A12	#115	.9	#25	#5DL31-3	0-6	23mm	2.0

\* Please Note: The following is for parts reference only. This Mikuni carburetor is no longer in production.

## VM29 Smoothbore Replacement Parts

• Lined through part numbers are no longer available.

No.	Description	Mikuni No.	Order No.	No.	Description	Mikuni No.	Order No.
1.	Mixing Body	VM29SS1/01B	_____	46.	Spring, Throttle Return	VM24/536	_____
2.	Mixing Body	VM29SS2/01B	_____	47.	E-Ring	BSW28/70	<b>002-355</b>
3.	Mixing Body	VM29SS3/01B	_____	48.	Ring, Throttle Lever	VM24/532	_____
4.	Mixing Body	VM29SS4/01B	_____	49.	Screw, Idle Adjusting	VM26/436	<b>002-537</b>
5.	Seal, Rubber	VM24/489	_____	50.	Spring, Idle Adjusting	BNO42/31	<b>002-538</b>
6.	End Cap, Rubber	VM28/559	_____	51.	Screw, Throttle Bracket	C5-510	_____
7.	O-Ring	BV30/40	<b>002-617</b>	52.	Bracket, Throttle	VM24/466	_____
8.	Fuel Joint	VM26/268	<b>007-748</b>	53.	Screw with Lock Washer	CW2=0514-B	<b>002-516</b>
9.	Fuel Joint	VM26/269	_____	54.	Plate	VM28/498	<b>002-517</b>
10.	Hose, Rubber	VM26-308	_____	55.	Spring, Shock	BN38/341	<b>007-491</b>
11.	Hose, Rubber Air Vent	VM15/217	_____	56.	Screw, Throttle Adjuster	N115.053	_____
12.	Air Jet	BS30/97	<b>Pg.213</b>	57.	Spring, Throttle Adjuster	N110.209	<b>002-655</b>
13.	Screw with Lock Washer	CW2-0307-G	<b>007-494</b>	58.	Screw, Back Plate	C5-0614	_____
14.	Screw, Starter Lever	VM28/269	_____	59.	Back, Plate	VM24/460	_____
15.	Spring, Starter Lever	VM28/293	<b>002-665</b>	60.	Bracket, Throttle Spring	VM24/513	<b>002-533</b>
16.	Washer (Steel)	VM28/449	<b>002-664</b>	61.	Screw, Throttle Spring Bracket	CW2=0514-B	<b>002-516</b>
17.	Washer (Nylon)	VM28/268	_____	62.	Screw with Spring Washer	CW2=0414	<b>002-522</b>
18.	Shaft, Starter	VM24/462	_____	63.	Cover, Top (Mixing Chamber)	VM24/507	_____
19.	Screw, Starter Lever	VM28-360	_____	64.	Gasket, Top Cover	VM28/549	<b>002-524</b>
20.	Starter Lever	VM26/435	<b>002-660</b>	65.	Bolt	VM28/230	<b>002-519</b>
21.	Filter Screen	VM18/233	<b>002-606</b>	66.	Lock Washer	W4=05-B	_____
22.	Washer, Valve Seat	B34/52-0.5	<b>002-187</b>	67.	Cap Screw	VM29/04	_____
23.	Needle Valve Assembly (2.5)	N122.032-2.5	<b>002-503</b>	68.	Spring	B21/20	_____
	Needle Valve Assembly (2.8)	N122.032-2.8	<b>002-504</b>	69.	Lock Washer Plate	VM28/233	_____
24.	Float Pin	BV26/22	<b>002-107</b>	70.	Lever Pull	VM28/554	_____
25.	Float Assembly.	VM26/260	<b>002-501</b>	71.	Pin (Top)	VM28/105	_____
26.	Gasket, Float Chamber (Bowl)	VM26/258	<b>002-502</b>	72.	Pin (Bottom)	VM20/05	_____
27.	Float Chamber (Bowl)	VM29/20 100	_____	73.	Plate	VM20/06	_____
28.	Screw with Lock Washer	CW2=0416-B	<b>002-615</b>	74.	Connector	VM20/07	_____
29.	O-Ring, Float Bowl Drain Plug	VM28/254	<b>002-531</b>	75.	Adjusting Screw	VM28/593	_____
30.	Drain Plug, Float Bowl	VM28/253	<b>002-526</b>	76.	Bolt, Link Lever	B2-0416	<b>002-539</b>
31.	E-Clip, Starter Plunger	KP/13	<b>002-673</b>	77.	Nut	N3=05	_____
32.	Bushing, Nylon	VM28/450	_____	78.	Plate, Set	VM28/594	_____
33.	Cap, Starter Plunger Rubber	VM20/455	<b>002-084</b>	79.	Spring	VM28/592	_____
34.	Fitting, Starter Plunger	VM28/359	_____	80.	Link Lever Assembly	VM29/17	_____
35.	O-Ring, Starter Plunger	VM18/249	<b>002-672</b>	81.	Screw with Lock Washer	CW2=0305	<b>002-527</b>
36.	Spring, Starter Plunger	VM16/42A	<b>002-671</b>	82.	Bracket, Connecting	VM29/08	_____
37.	Starter Plunger	VM24/510	<b>002-670</b>	83.	Pin, Jet Needle Retaining	VM29/14	_____
38.	Pilot Air Screw	VM26/288	<b>002-506</b>	84.	Pin, Jet Needle Retaining	VM20/369	<b>002-083</b>
39.	O-Ring, Pilot Air Screw	VM14/75	<b>002-676</b>	85.	Jet Needle	J8-5DL31	<b>002-268</b>
40.	Spring, Pilot Air Screw	M12F/46A	<b>002-181</b>	86.	Throttle Valve 1.5	VM29/15	<b>003-168</b>
41.	Pilot Jet	VM22/210	<b>Pg.212</b>		Throttle Valve 2.0	VM29/15	<b>003-169</b>
42.	Needle Jet O-6 (Std)	#261 Series	<b>003-535</b>		Throttle Valve 2.5	VM29/15	<b>003-170</b>
43.	Main Jet	N100.604	<b>Pg.214</b>	87.	Jet Block	VM29/10	_____
44.	Throttle Shaft	VM29/11	<b>002-513</b>	88.	Gasket, Jet Block	VM29/13	<b>002-535</b>
45.	Lever, Throttle Shaft	VM24/533	_____	89.	Warning Tag	VM33/78	_____

## VM29 Needle Valve Assembly

No.23 in exploded view.

Size	Mikuni No.	Order No.
2.5	N122.032-2.5	<b>002-503</b>
2.8	N122.032-2.8	<b>002-504</b>

## VM29 Throttle Valves

No.86 in exploded view.

Cutaway	Mikuni No.	Order No.
1.5	VM29/15	<b>003-168</b>
2.0	VM29/15	<b>003-169</b>
2.5	VM29/15	<b>003-170</b>



## Honda CB750 Intake Manifolds

CB750 Intake Manifolds for SOHC **005-026**.  
Use when mounting VM29 smoothbores.

# IKUNI VM33 Smoothbore Exploded View

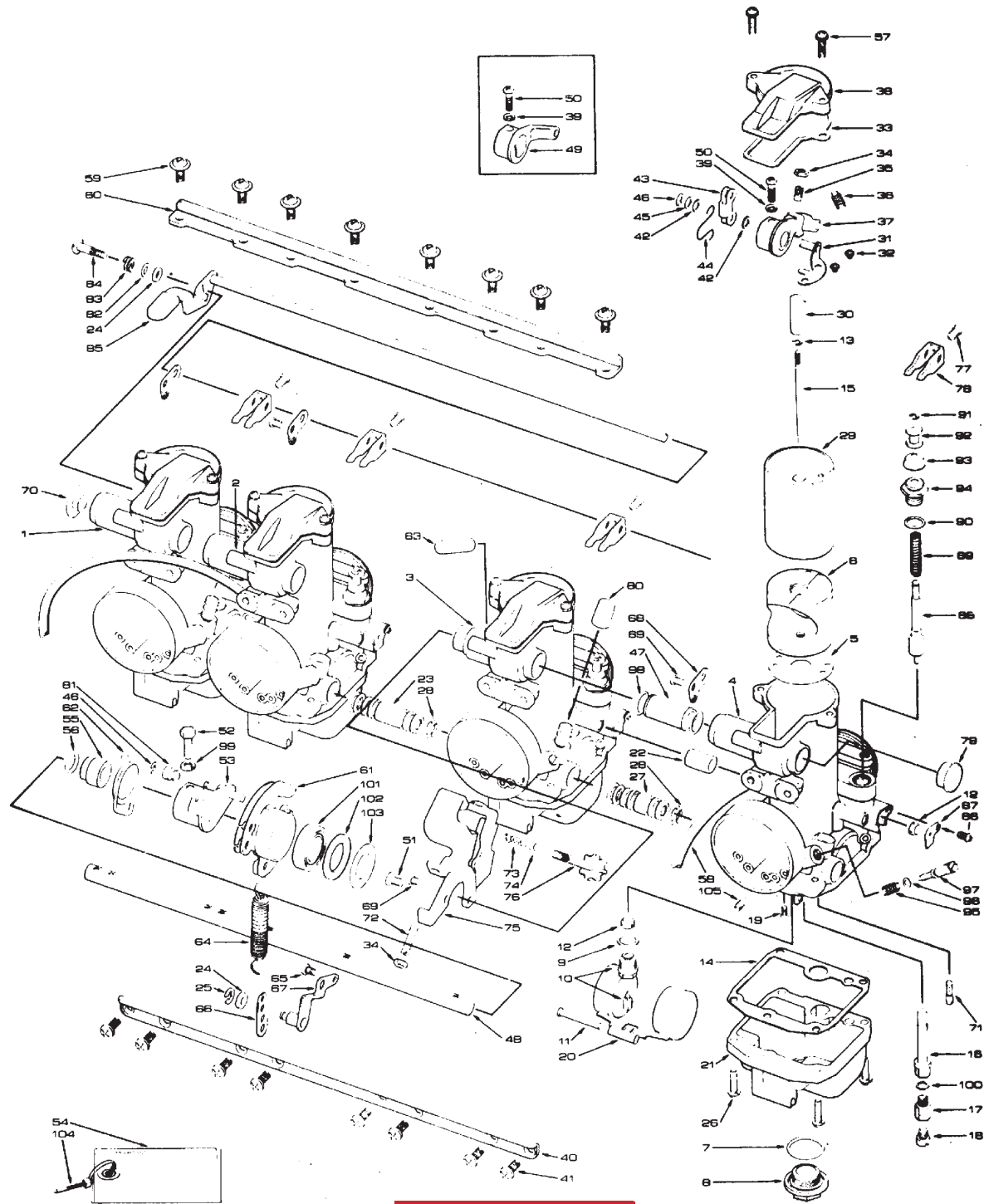

**Float Height**  
**23mm**

## Standard Jetting Specifications VM33 Smoothbore

Application	Carb Model	Main Jet N100.604	Air Jet BS30/97	Pilot Jet VM22/210	Jet Needle	Needle Jet #261 Series	Float Height	Throttle Valve 832-39003
Honda CB900/1100F	VM33-A4	#125	.7	#30	#6DJ30-2	0-8	23mm	1.5
Kawasaki KZ1000/1100	VM33-A14	#127.5	1.2	#17.5	#6DJ30-4	0-6	23mm	1.5
Suzuki GS1000/1100	VM33-A14	#132.5	.6	#17.5	#6DJ30-4	0-6	23mm	2.0
Yamaha XS1100	VM33-A14/D45	#132.5	.9	#17.5	#6DJ30-4	0-6	23mm	2.0
Kawasaki ZX900, 1000 Ninja	VM33-A14/D45	#125	.9	#20	#6DJ30-4	P-0	23mm	2.0

\* Please Note: The following is for parts reference only. This Mikuni carburetor is no longer in production.

## VM33 Smoothbore Replacement Parts

• Lined through part numbers are no longer available.

No.	Description	Mikuni No.	Order No.	No.	Description	Mikuni No.	Order No.
1.	Mixing Body	VM33SS101/01B	_____	52.	Bolt	VM28/230	<b>002-519</b>
2.	Mixing Body	VM33SS101/01C	_____	53.	Lever Assembly	VM33/26	<b>002-638</b>
3.	Mixing Body	VM33SS102/01C	_____	54.	Name Plate	VM33/78	_____
4.	Mixing Body	VM33SS103/01B	_____	55.	Collar	VM33/68A	<b>002-639</b>
5.	Gasket	VM33/31	<b>002-600</b>	56.	Seal, Felt	VM28/403	<b>002-640</b>
6.	Jet Block	VM33/20	_____	57.	Screw with Lock Washer	CW2=0416B	<b>002-615</b>
7.	O-Ring	BNO42/64	<b>002-602</b>	58.	Hose, Air Vent	N149.030	<b>002-641</b>
8.	Drain Plug	TM32/41	<b>007-646</b>	59.	Screw	N138.186	<b>002-642</b>
9.	Washer, Needle Valve	B34/52-0.5	<b>002-187</b>	60.	Bracket Plate, Rear	VM33/67	<b>002-643</b>
10.	Assembly, Needle Valve (2.5)	N122.032-2.5	<b>002-503</b>	61.	Bell Crank Assembly	VM33/38	<b>002-644</b>
	Assembly, Needle Valve (2.8)	N122.032-2.8	<b>002-504</b>	62.	Spring	VM33/35	<b>002-645</b>
11.	Float Pin	VM30/160	<b>002-605</b>	63.	Vacuum Cap	N148.013	<b>002-646</b>
12.	Filter Screen	VM18/233	<b>002-606</b>	64.	Throttle Return	VM22/349	<b>002-647</b>
13.	E-Ring	VM20/369	<b>002-083</b>	65.	Screw	C2-0508-B	<b>002-648</b>
14.	Gasket, Float Bowl	VM30-257	<b>002-607</b>	66.	Adjuster Plate	VM33/34	<b>002-649</b>
15.	Jet Needle	J8-6DJ30	<b>002-340</b>	67.	Bracket	VM33/23	<b>002-650</b>
16.	Needle Jet	#261 Series, O-8	<b>003-536</b>	68.	Choke Shaft Plate	VM33/58	_____
17.	Main Jet Extender	697-05001A	<b>002-608</b>	69.	Screw	C2-408-B	<b>002-652</b>
18.	Main Jet	N100.604	<b>Pg.214</b>	70.	Cap, Side	VM33/63	<b>002-653</b>
19.	Screw	C6=0307	<b>002-609</b>	71.	Pilot Jet	VM22/210	<b>Pg.212</b>
20.	Float Assembly	VM26/260	<b>002-501</b>	72.	Adjuster Screw	N138.049A	<b>002-654</b>
21.	Float Chamber Body	VM29/20-100	_____	73.	Spring	N110.209	<b>002-655</b>
22.	Hose, Air Vent	888-36003A	_____	74.	Washer	N141.217	_____
23.	Fuel Nipple	792-20008	<b>002-612</b>	75.	Main Bracket	VM33/43	_____
24.	Washer	VM28/268	_____	76.	Adjuster Screw	603-25001A	_____
25.	E-Ring	BN38/135	<b>002-614</b>	77.	Screw	N158.052	<b>002-659</b>
26.	Screw with Lock Washer	CW2=0416-B	<b>002-615</b>	78.	Lever	VM26/435	<b>002-660</b>
27.	Fuel Nipple	792-20007	_____	79.	Cap Side	VM33/70	<b>002-661</b>
28.	O-Ring	BV30/40	<b>002-617</b>	80.	Fuel Cap	VM33/72	_____
29.	Throttle Valve 1.5	832-39003-1.5	<b>003-198A</b>	81.	Ring	VM24/532	_____
	Throttle Valve 2.0	832-39003-2.0	<b>003-198</b>	82.	Washer	VM28/449	<b>002-664</b>
	Throttle Valve 2.5	832-39003-2.5	<b>003-198B</b>	83.	Spring	VM28/293	<b>002-665</b>
30.	Bushing Collar	VM33/60	_____	84.	Screw	VM28/269	_____
31.	Bracket Assembly	VM33/71	<b>002-619</b>	85.	Choke Shaft Assembly	VM33/56A	_____
32.	Screw with Lock Washer	CW2=0305	<b>002-527</b>	86.	Screw	C2-0306-B	<b>002-668</b>
33.	Gasket, Top Cover	VM33/32	<b>002-620</b>	87.	Side Plate	VM33/59	<b>002-669</b>
34.	Adjuster Nut	N138.050	<b>002-621</b>	88.	Starter Plunger	VM24/510	<b>002-670</b>
35.	Adjuster Screw	VM33/21	_____	89.	Plunger Spring	VM16/42A	<b>002-671</b>
36.	Screw	730-06005	_____	90.	O-Ring	VM18/249	<b>002-672</b>
37.	Lever Assembly	VM33/64	<b>002-624</b>	91.	E-Ring	KP/13	<b>002-673</b>
38.	Top Cover	776-39001	<b>002-625</b>	92.	Ring	VM28/450	_____
39.	Lock Washer	W4-04-0	<b>002-626</b>	93.	Rubber Cap	VM20/455	<b>002-084</b>
40.	Bracket Plate, Front	VM33/75	<b>002-627</b>	94.	Guide Holder	VM38/359	_____
41.	Screw	C2-0512-B	<b>002-628</b>	95.	Spring	M12F/46A	<b>002-181</b>
42.	Washer (Polyester)	B40I/10	<b>002-629</b>	96.	O-Ring	M14/75	<b>002-676</b>
43.	Plate, Connecting	VM33/45	<b>002-630</b>	97.	Air Screw	VM26/287	<b>002-677</b>
44.	Spring	VM33/49	<b>002-631</b>	98.	O-Ring	0S/05B	_____
45.	Washer	M10/56	<b>002-632</b>	99.	Lock Washer	W4-05	<b>002-679</b>
46.	E-Ring (Clip)	BSW28/70	<b>002-355</b>	100.	Washer	BV23/196	<b>002-680</b>
47.	Collar Pipe	813-28001	<b>002-633</b>	101.	Bearing	VM33/61	_____
48.	Shaft	700-17003A	<b>002-634</b>	102.	Seal, Felt	VM33/37	_____
49.	Lever Assembly	VM33/52A	_____	103.	Washer	946-17001	<b>002-683</b>
50.	Screw	VM33/73	<b>002-636</b>	105.	Air Jet	BS30/97	<b>Pg.213</b>
51.	Screw	C5=0510	_____	106.	Restrictor	VM33/82	<b>002-684</b>

## VM33 Needle Valve Assembly (No.10 exploded view)

Size	Mikuni No.	Order No.
2.5	N122.032-2.5	<b>002-503</b>
2.8	N122.032-2.8	<b>002-504</b>

## VM33 Throttle Valves (No.29 exploded view)

Cutaway	Mikuni No.	Order No.
1.5	832-39003	<b>003-198A</b>
2.0	832-39003	<b>003-198</b>
2.5	832-39003	<b>003-198B</b>

VINTAGE  
INTAKE  
ENGINE  
SUSPENSION  
CONTROL  
ELECTRICAL  
CHEMICAL  
TOOLS  
WATERCRAFT

# Mikuni HSR Carburetor Kits



## Easy Kits for Sportsters, Big Twin & Twin Cam

These kits are designed to work with your original Harley-Davidson® intake manifold, choke cable, air cleaner and throttle cables. You can run other high performance air filters designed for the CV type carb by using the special adapter included in kit. Dramatically improves the performance and delivers unmatched throttle response and acceleration.

### Harley-Davidson®

1340 Big Twin Evolution (1990-1999) with stock CV Type Manifold

Order No. **001-602**

Mikuni No. 42-7. Kit includes HSR42mm carburetor, airbox adapter and chrome cover.

Twin Cam (1999 to present), Big Twin (1990-1999)

Order No. **001-621**

Mikuni No. 42-18. Kit includes HSR42mm carburetor and airbox adapter. Twin Cam model use stock oval cover. Works with Screamin Eagle air filter.

Sportster 1200 (1994-2004)

Order No. **001-605**

Mikuni No. 42-10. Kit includes HSR42mm carburetor with special airbox back plate. Requires the use of the stock oval cover and a Screamin Eagle high flow replacement air filter.

Sportster 1200 (1994-2006), Buell models

Order No. **001-606**

Mikuni No. 42-11. Must use with aftermarket performance air filter.

## HSR Race Kit 48mm for Big Motors

These kits are designed for the serious race engine builder and extreme street motor enthusiast looking for more power. Recommended for 1200cc engines or bigger with high flow cylinder heads and performance cams.

HSR48 Race Kit 48-2

Order No. **001-635**

Includes 48mm smoothbore carb, rubber mounting flange (78mm bolt hole centers), choke cable and main jets. Uses stock Harley Big Twin CV type throttle cables.

**Note: Manifold, air filter or velocity stack not included.**

HSR48 Race Kit 48-2P

Order No. **001-560**

Includes 48mm polished smoothbore carb, rubber mounting flange (78mm bolt hole centers), choke cable and main jets.

**Note: Manifold, air filter or velocity stack not included.**

Carburetor Kits not designated as C.A.R.B. exempt are not legal for motor vehicles operated on public highways in the state of Ca., or in other states and countries where similar anti-pollution laws may apply.



## Total Kits for Big Twin Evolution & Twin Cam

These kits include an HSR42 or HSR45 carburetor, performance manifold, rubber flange, high flow air filter, chrome cover, chrome breather kit and mounting hardware. Total Kits allow fitment of a HSR42 or HSR45mm carburetor to any Big Twin Evolution or Twin Cam model. Manifold clamps and seals are not included in kit.

### Harley-Davidson®

Twin Cam 88/95 (1999 to present)

Order No. **001-622**

Mikuni No. 42-19. Includes Breather Kit #KHS-030 for Twin Cams.

**Note:** Use your stock throttle cables.

Twin Cam 88/95 (1999 to present)

Order No. **001-630**

Mikuni No. 45-4. Includes Breather Kit #KHS-030 which utilizes MAP location.

**Note:** Uses stock CV type throttle cables.

1340 Big Twin Evolution (1984-1999)

Order No. **001-603**

Mikuni No. 42-8. Includes Breather Kit #KHS-020 for 1993 and later models.

**Note:** 1984 to 1989 models require throttle cables from 1990 to 1995 model bikes. Do not use on 1984-1988 FLT models. Gas Tank may hit carburetor.

1340 Big Twin Evolution (1984-1999)

Order No. **001-610**

Mikuni No. 45-2. Includes breather kit #KHS-020.

**Note:** 1984 to 1989 models require throttle cables from 1990 to 1995 model bikes. Do not use on 1984-1988 FLT models. Gas Tank may hit carburetor.

1340 Big Twin Evolution (1984-1999)

Order No. **001-611**

Mikuni No. 45-3. Includes breather kit #KHS-020 and a 45mm flange. Intake Manifold not included in kit. **Note:** 1984 to 1989 models require throttle cables from 1990 to 1995 model bikes. Do not use on 1984-1988 FLT models. Gas Tank may hit carburetor.







## Mikuni Individual HSR Carburetors

For the performance engine builder needing the carburetor only for specific custom applications. Available in standard aluminum finish or polished version.

Description	Mikuni No.	Order No.
42mm Carb only, standard finish	TM42-6	001-549
42mm Carb only, polished finish	TM42-6PK	001-551
45mm Carb only, standard finish	TM45-2K	001-554
45mm Carb only, polished finish	TM45-2PK	001-555
48mm Carb only, standard finish	TM48-1	001-558
48mm Carb only, polished finish	TM48-1PK	001-559

**Note:** 001-549 - use stock choke cable from H-D CVK type carb.



## HSR42/45/48 Carburetor Rebuild Kits

Kits contain all the necessary parts and gaskets to rebuild an HSR carburetor. Includes needle valve assembly, o-rings, gaskets and screws. Sold as a kit.

Description	Mikuni No.	Order No.
HSR42/45mm Carburetor Rebuild kit	KHS-016	002-989
HSR48mm Carburetor Rebuild kit	KHS-031	002-982

Qt	Contents
1	Gasket, Top Cover
1	E-Ring, Jet Needle
1	Washer, Jet Needle
1	O-Ring, Pilot Air
2	O-Ring, Fuel Joint
1	O-Ring, A/P
1	O-Ring, Needle Valve
1	Screw, N.V. Retainer
1	Needle Valve Assy #4.2 (HSR42/45)
1	Needle Valve Assy #4.5 (HSR48)
1	Packing, Float Bowl
1	Hose, Overflow
1	O-Ring, Drain Plug
4	Screw, Float Bowl (short)
1	Boot, A/P Rod



## HSR42 Dealer Jet Assortment Kit

This jet assortment kit contains 44 pieces in a special jet box. Included are qt 2 each #150 thru #170 main jets, qt 2 each #20 thru #32.5 pilot jets, qt1 each #96, #97 and #98 needles, qt2 each #60 a/p nozzles, needle clips and washers. Sold as a kit.

Description	Mikuni No.	Order No.
44 Pc. Jet Kit Assortment with storage box	KHS-025	002-983

## HSR45 & HSR48 Dealer Jet Assortment Kit

Description	Mikuni No.	Order No.
HSR45 Jet Kit	KHS-045	002-976
HSR48 Jet Kit	KHS-048	002-977



## HSR Accelerator Pump Nozzles

Description	Mikuni No.	Order No.
Standard	TM42/11-70	007-487
Leaner	TM42/11-60	007-486
Leanest	TM42/11-50	007-485



## HSR Needle Valve Assemblies

Size	Description	Mikuni No.	Order No.
(2.3)	Fuel Pump	786-27001	007-478
(3.5)	Offroad	786-27001	007-477
(4.2)	Std on HSR42/45	786-27001	007-476
(4.5)	Std on HSR48	786-27002-1A-4.5	007-708
	O-ring for Needle Valve Seat	616-33003	007-470



## HSR Main Jet Extender Kit

Description	Mikuni No.	Order No.
Main Jet Extender Kit	KHS-034	002-978

# Mikuni HSR42/45/48 Parts & Accessories



## HSR Intake Performance Manifolds

Description	Mikuni No.	Order No.
Intake Manifold for HSR42/45 Evo Style without hole.	HS42/061-45	007-459
Intake Manifold for HSR42/45 Twin Cam Style with MAPS hole.	HS42/061-45TC	007-457

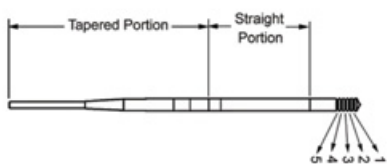

## HSR Jet Needles

Sold each. See page 204 for Jet Needle details.  
No.7 in exploded view on page 174, -Old style, New Style page 176.

Jet Needle No.	Needle Diameter before Taper (mm)	Air/Fuel Ratio	Order No.
Applications: <b>HSR42</b>			
#8DDY01-98	2.98	Leaner	007-083
#8DDY01-97 (Std)	2.97	↕	007-082
#8DDY01-96	2.96	↕	007-081
#8DDY01-95	2.95	Richer	007-080
Applications: <b>HSR45</b>			
#8CFY02-98	2.98	Leaner	007-103
#8CFY02-97 (Std)	2.97	↕	007-102
#8CFY02-96	2.96	↕	007-101
#8CFY02-95	2.95	Richer	007-100
Applications: <b>HSR48</b>			
#8CFY15-98	2.98	Leaner	007-098
#8CFY15-97 (Std)	2.97	↕	007-097
#8CFY15-96	2.96	↕	007-096
#8CFY15-95	2.95	Richer	007-095

## HSR K&N Air Filters & Chrome Covers

Description	Mikuni No.	Order No.
K&N Air Filter for HSR 2.5" thick Standard in HSR Kits, washable	HS42/012	007-463
K&N Air Filter for HSR 3.0" thick Extra Wide, High-Performance, washable	HS42/012-300	007-466
Chrome Air Filter Cover, no cut-outs	HS42/060	007-464
Chrome Air Filter Cover, OEM with cut-outs	HS42/059	007-462



## HSR Air Box Adapter Kit

Kit includes air box adapter, qt 3 screws and o-ring.  
Mikuni part number HS42-001K

Order No. 007-455

### Individual Replacement Parts - Sold each.

Description	Mikuni No.	Order No.
Air Box Adapter	HS42/001	007-450
Adapter Screw	HS42/002	007-453
O-Ring Seal for Air Box Adapter	HS42/003	007-454



## Rubber Mounting Flanges w/Clamp

Sold each.

Application	Mikuni No.	Order No.
H-D® HSR42 to 2 bolt flange (round)	HS42/018-42K	007-460
H-D® HSR45 to 2 bolt flange (round)	HS42/018-45K	007-461
H-D® HSR48 to 2 bolt flange (oval)	HS42/062-48K	007-467
H-D® HSR42 to 2 bolt flange (oval)	HS42/062-42K	007-468
H-D® HSR42 to 2 bolt flange (oval)	HS42/062-45K	007-469

## HSR Short Idle Screw (Optional)

No.55A in old style HSR parts list on page 175 and No. 59A in New Style HSR parts list on page 177. Optional shorter length for all HSR42/45/48. Sold each.

Mikuni No.	Order No.
990-605-065	007-484

**Note:** Do not modify the idle screw or any of its component pieces. If the screw is removed, be sure to re-install with the components in place as shown in the exploded view on page 174 and page 176.



## HSR Chrome Carb Top

Top cover with HSR logo and gasket. For HSR42 and HSR45 Carburetors. Sold each.

Mikuni No. KHS-029      Order No. 002-991



## HSR Crankcase Head-Breather Kit

To mount the HSR42/45 carb and filter to EVO Big Twins and Twin Cam.

Mikuni No. KHS20.      Order No. 002-984

Fits EVO Big Twins, 1991 to present Sportsters and 1993 to present 1340's. Includes chrome banjo's, vent bolts and brackets.

Mikuni No. KHS30.      Order No. 002-981

1999 to present Twin Cam 88/95. Includes chrome banjo's, vent bolts and brackets.



## HSR Easy Tool Kit

The Easy Tool Kit includes an Easy Wrench with 17mm x 11/16" open end wrench, Mini-T Jet Wrench with Phillips & Flat head blades and a 2.5mm Ball End Allen bit with 6mm hex.

Mikuni No. KHS-033.      Order No. 002-046



007-764

007-465

## HSR Air Filter Mounting Bracket

Chrome Air Filter mounting bracket is used for bikes w/o breather kit. Chrome Breather Bracket is from crankcase head breather kits. Sold each.

Mikuni No.      Order No.

HS42/067 Air Filter Bracket      007-764

HS42/019 Air Filter Bracket      007-465



007-208



007-761



## HSR Throttle Cables

Sold each.

HSR42/45 from 1994 to 1999 required Mikuni throttle cables.

HSR42 carbs made after May 1999, and HSR45 made after March 2000 use stock Harley-Davidson® cables.

Note: Open = Throttle, Close = Idle.

Fitment: 1970 to 1995 Screw in Type for Early HSR42/45

Description	Notes	Mikuni No.	Order No.
Open (Pull) Cable	Standard (38")	HS42/028A	007-451
Close (Push) Cable	Standard (38")	HS42/029A	007-452
Open (Pull) Cable	Dresser (47")	KHS/039	007-550
Close (Push) Cable	Dresser (47")	KHS/040	007-551

Fitment: 1996 to Present Push in Type

Open (Pull) Cable	Standard (38")	KHS/043	007-554
Close (Push) Cable	Standard (38")	KHS/044	007-555
Open (Pull) Cable	Dresser (47")	KHS/041	007-552
Close (Push) Cable	Dresser (47")	KHS/042	007-553

Fitment: Buell Late Style 1999

Push/Pull Cable Set	Late Style HSR	01-0714	021-937
---------------------	----------------	---------	---------

## HSR Choke Cable & Choke Pull Assemblies

Fits all style HSR42/45/48. Sold each.

Description	Mikuni No.	Order No.
Choke Cable Assembly	990-662-002	007-208
Choke Pull Assembly	TM29/31	007-761
Chrome Bracket	RS36/23	007-688

# IKUNI HSR42/45 Old Style Exploded View

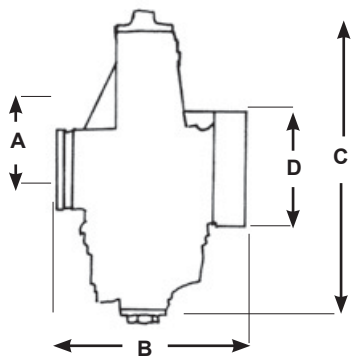
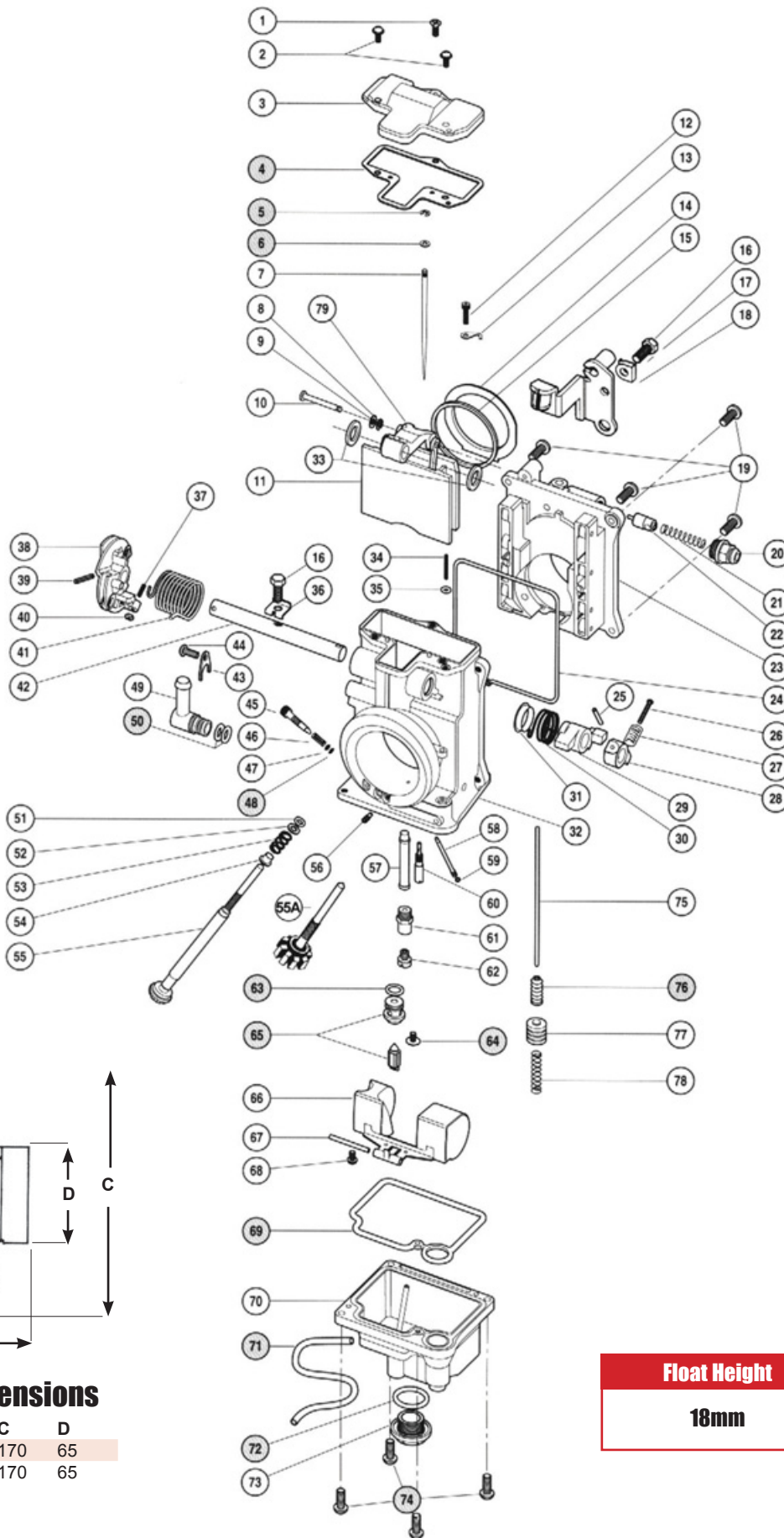

## Carburetor Dimensions

Size (mm)	A	B	C	D
HSR42	46	90	170	65
HSR45	46	90	170	65

**Float Height**  
**18mm**

Not LEGAL for sale or use in California on pollution controlled motor vehicles, or in other states where similar laws may apply.



## HSR42/45 Old Style Replacement Parts

• Lined through part numbers are no longer available.

Mikuni Part No. Highlighted in **BOLD RED** are included in rebuild kit.

No.	Description	Mikuni No.	Order No.
1.	Screw, Top Cover 4x10mm	C5=410-B	007-624
2.	Screw, Top Cover 4x14mm (qt2)	CW2=0414-B	002-522
3.	Top Cover	776-39005	007-741
4.	Gasket, Top Cover	<b>TM42/04</b>	007-480
5.	E-Ring, Jet Needle	<b>BS32/126</b>	002-455
6.	Washer, Jet Needle	<b>826-03002</b>	007-267
7.	Jet Needle (HSR42) Std.	J8-8DDY01-96	007-082
	Jet Needle (HSR45) Std.	J8-8CFY02-96	007-102
8.	E-Ring	B40I/56	007-616
9.	Packing, Link Lever	B40I/10	002-629
10.	Pin, Link Lever	834-23041	007-743
11.	Throttle Valve 3.0	TM42/08-3.0	007-432
12.	Screw, Needle Retainer	739-13001	007-123
13.	Clip, Needle Retainer	TM42/16	007-671
14.	Sealing Ring, Throttle Valve	TM42/13	007-723
15.	Seal, Throttle Valve	TM42/10	007-670
16.	Bolt	TM40/89	007-669
17.	Plate, Lock Tab	TM42/38	007-675
18.	Bracket, Cable ( <b>Standard</b> )	TM42/34	007-740
	Used on Old Style HSR42/45 manufactured before 2000.		
	Throttle Linkage is on left side.		
18A.	Bracket, Cable ( <b>Lower Position</b> )	TM42/34A	_____
	(Lower Bracket, lowers cable position, use with larger fuel tanks )		
19.	Screw	C2=0514-B	007-698
20.	Starter Nut, Choke	640-12001	007-161
21.	Spring, Starter Plunger	VM14/241	007-678
22.	Starter Plunger	N189.192	007-635
23.	Mixing Body (HSR42/45)	TM42/06	_____
	Mixing Body (HSR48)	TM48/02	_____
24.	Seal, Spigot Body	616-94029	007-473
25.	Pin, A/P Throttle Lever	BN38/43	007-617
26.	Screw, A/P	MC-0316-B	007-193
27.	Spring, A/P	M12F/46-BB	007-629
28.	Lever, A/P	TM42/28	_____
29.	Lever, A/P	TM42/21	007-721
30.	Spring, A/P	TM42/37	_____
31.	Ring	E204.040	007-628
32.	Mixing Body Assembly	TM42SS1/01-0	_____
33.	Packing, Shaft	BS36/95	007-615
34.	Adjusting Screw, A/P	TM42/36	007-701
35.	O-Ring, A/P Screw	B30/205	007-188
36.	Shaft Lock, Tab	TM42/17	007-703
37.	Screw, Throttle Stop	B30/1069	007-746
38.	Lever Assembly, Throttle	TM42/20	007-673
39.	Pin, Throttle Lever	N138.019	007-171
40.	Nut, Throttle Stop Screw	N3=4	007-637
41.	Spring, Throttle Return	TM42/19	007-672
42.	Shaft, Throttle	700-15011	_____
43.	Plate, Fuel Joint Retainer	TM42/15	007-704
44.	Screw	C2=0410-B	007-705
45.	Screw, Pilot Air Adjusting ( <b>Std</b> )	604-26014	007-706
46.	Spring, Pilot Air Adjusting	N133.206	007-137
47.	Washer, Pilot Air Adjusting	VM12/205	007-482
48.	O-Ring, Pilot Air Adjusting	<b>N133.037</b>	002-858
49.	Fuel Joint	TM40/27	007-667
50.	O-Ring, Fuel Joint	<b>KV/10</b>	002-709
51.	Packing, Idle Adjuster	B30/398	007-614
52.	Washer, Idle Adjuster (Steel)	VM22/138	007-680
53.	Spring, Idle Adjuster	730-09018	007-603
54.	Ring, Idle Adjuster (Brass)	925-15001	007-612
55.	Idle Adjuster Assembly (Long)	TM42/32	007-674
55A.	Idle Adjuster Screw (Short)	999-605-065	007-484
56.	Air Jet (Blank)	BS30/97-00	002-149
57.	Needle Jet #723 Series	784-430000-Y-6	<b>Pg.206</b>
58.	Nozzle, Accelerator Pump Std.	TM42/11-70	007-487
59.	O-Ring, A/P	<b>N124.063</b>	007-163

Note: Old Style HSR42/45 were manufactured before year 2000.

Throttle linkage is on left.

No.	Description	Mikuni No.	Order No.
60.	Pilot Jet #30 ( <b>Std.</b> )	VM28/486	004-034
	Pilot Jet - Optional Sizes	VM28/486	<b>Pg.212</b>
61.	Extender, Main Jet	TM42/12	007-722
62.	Main Jet #160 ( <b>Std.</b> )	N100.604	004-204
	Main Jet - Optional Sizes	N100.604	<b>Pg.214</b>
63.	O-Ring, Needle Valve Seat	<b>616-33003</b>	007-470
64.	Screw, Needle Valve Retainer	<b>VM13/216</b>	007-174
65.	Needle Valve Assembly w/O-Ring	<b>786-27001-4.2</b>	007-476
66.	Float Assembly	859-32027	007-497
67.	Pin, Float	BV26/22	002-107
68.	Screw, Float Pin	C2=0410	007-620
69.	Packing, Float Bowl	<b>616-94028</b>	007-472
70.	Float, Chamber Body	TM42/05	007-500
71.	Hose, Overflow	<b>N122.028</b>	007-630
72.	O-Ring, Drain Plug	<b>VM28/254</b>	002-531
73.	Drain Plug	TM32/41	007-646
74.	Screw, Float Bowl	<b>C2=0412-B</b>	007-201
75.	Rod, A/P	TM36/44-1A	007-191
76.	Boot, A/P	<b>TM36/64</b>	007-195
77.	Plunger, A/P	TM36/60	007-198
78.	Spring, A/P	VM14SC13/89	007-200
79.	Lever, T.V.	TM42/03	007-742



## HSR42/45 Carburetor Rebuild Kit

Kit contains GENUINE Mikuni parts, all the necessary parts and gaskets to rebuild an HSR carburetor. Includes needle valve assembly, o-rings, gaskets and screws. Sold as a kit.

Mikuni No. KHS-016. Order No. **002-989**

### Exploded

View No.	Qt	Contents
4	1	Gasket, Top Cover
5	1	E-Ring, Jet Needle
6	1	Washer, Jet Needle
48	1	O-Ring, Pilot Air
50	2	O-Ring, Fuel Joint
59	1	O-Ring, A/P
63	1	O-Ring, Needle Valve
64	1	Screw, N.V. Retainer
65	1	Needle Valve Assy
69	1	Packing, Float Bowl
71	1	Hose, Overflow
72	1	O-Ring, Drain Plug
74	4	Screw, Float Bowl (short)
76	1	Boot, A/P Rod

# Mikuni HSR42/45/48 New Style Exploded View

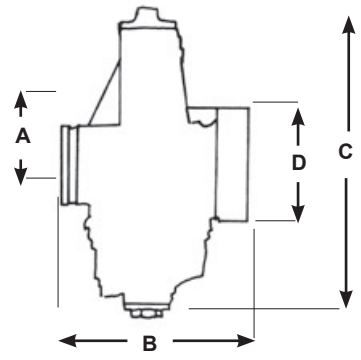
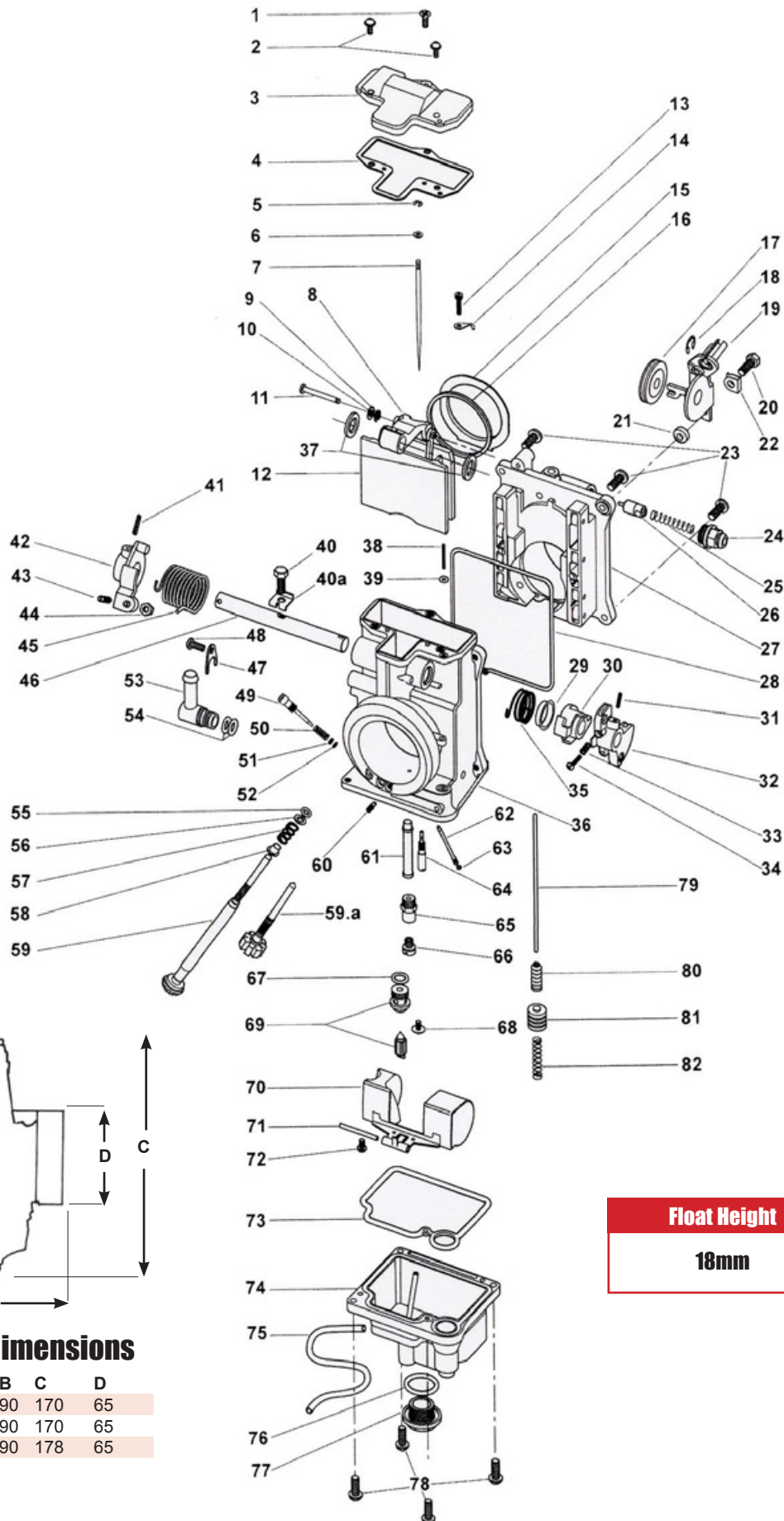

## Carburetor Dimensions

Size (mm)	A	B	C	D
HSR42	46	90	170	65
HSR45	49	90	170	65
HSR48	53	90	178	65

**Float Height**  
**18mm**

**IMPORTANT:** Mikuni HSR Carburetors are legal in California only for RACING vehicles which may never be used upon a public street or highway. In other locations check for similar laws which may apply.

## HSR42/45/48 New Style Replacement Parts

• Lined through part numbers are no longer available.

Mikuni Part No. Highlighted in **BOLD RED** are included in rebuild kit.

No.	Description	Mikuni No.	Order No.
1.	Screw, Top Cover 4x10mm	C5=410-B	007-624
2.	Screw, Top Cover 4x16mm (qt2)	CW2=0416-B	002-615
3.	Top Cover (HSR42/45)	776-39005	007-741
3A.	Top Cover (HSR48)	HS42/081	007-691
4.	Gasket, Top Cover	TM42/04	007-480
5.	E-Ring, Jet Needle	BS32/126	002-455
6.	Washer, Jet Needle Clip	826-03002	007-267
7.	Jet Needle (HSR42) Std.	J8-8DDY01-97	007-082
	Jet Needle (HSR45) Std.	J8-8CFY02-97	007-102
	Jet Needle (HSR48) Std.	J8-8CFY15-97	007-097
8.	Lever, Throttle Valve (HSR42/45)	TM42/03	007-742
8A.	Lever, Throttle Valve (HSR48)	TM42/08-1A	
9.	E-Ring, Link Lever	B40I/56	007-616
10.	Packing, Link Lever	B40I/10	002-629
11.	Pin, Link Lever	834-23041	007-743
12.	Throttle Valve (Slide)	TM42/08-3.0	007-432
13.	Screw, Needle Retainer	739-13002	007-692
14.	Clip, Needle Retainer	TM42/16	007-671
15.	Sealing Ring, T.V. (HSR42/45)	TM42/13	007-723
15A.	Sealing Ring, T.V. (HSR48)	TM48/04	
16.	Seal, Throttle Valve	TM42/10	007-670
17.	Pulley, Cable Bracket	925-98006	007-693
18.	E-Ring, Cable Bracket	T53974	007-694
19.	Bracket Assy., Cable	TM42/51	007-695
19A.	Bracket Assy., Sportster/Buell	TM42/53	007-724
20.	Bolt, Bracket	B3=0520-B	007-696
21.	Spacer, Bracket	VM28/204	007-697
22.	Plate, Lock Tab	TM42/38	007-675
23.	Screw	C2=0514-B	007-698
24.	Guide Holder (Starter)	640-12001	007-161
25.	Spring, Starter Plunger	VM14/241	007-678
26.	Starter Plunger	N189.192	007-635
27.	Body (HSR42/45)	TM42/06	
27A.	Body (HSR48)	TM48/02	
28.	Seal, Spigot Body	616-94029	007-473
29.	Ring (Steel)	925-19011	
30.	Lever, A/P	TM42/43	007-699
31.	Pin, Throttle Lever	N138.019	007-171
32.	Lever, Throttle	TM42/48	007-700
33.	Spring, Accelerator Pump	M12F/46-BB	007-629
34.	Screw, Accelerator Adjust	MC-0316-B	007-193
35.	Spring, Accelerator Pump	TM42/47	007-744
36.	Mixing Body (HSR42/45)	TM48SS1/01-0	
36A.	Mixing Body (HSR48)	TM48SS1/01	
37.	Packing, Shaft (Plastic)	BS36-95	007-615
38.	Adjusting Screw, A/P	TM42/36	007-701
39.	O-Ring, A/P Screw	B30/205	007-188
40.	Bolt	TM40/89	007-669
40A.	Plate, Lock Tab for Shaft	TM42/17	007-703
41.	Pin, Return Lever	BN38/43	007-617
42.	Lever, Return	TM42/46	007-745
43.	Screw, Throttle Stop	B30/1069	007-746
44.	Nut, Throttle Stop	N3=04	007-637
45.	Spring, Throttle Return	TM42/19	007-672
46.	Shaft, Throttle	700-15012	
47.	Plate, Fuel Joint Retainer	TM42/15	007-704
48.	Screw, Fuel Joint Retainer	C2=0410-B	007-705
49.	Screw, Pilot Air Adjusting	604-20614	007-706
50.	Spring, Pilot Air Screw	N133.206	007-137
51.	Washer, Pilot Air Screw	VM12/205	007-482
52.	O-Ring, Pilot Air Screw	N133.037	002-858
53.	Fuel Joint	TM40/27	007-667
54.	O-Ring, Fuel Joint	KV/10	002-709
55.	Packing, Idle Adjuster	B30/398	007-614
56.	Washer, Idle Adjuster (steel)	VM22/138	007-680
57.	Spring, Idle Adjuster	730-09018	007-603
58.	Ring, Idle Adjuster	925-15001	007-612
59.	Idle Adjuster Screw (Long)	TM42/32	007-674

No.	Description	Mikuni No.	Order No.
59A.	Idle Adjuster Screw (Short)	990-605-065	007-484
60.	Air Jet (Blank)	BS30/97	002-149
61.	Needle Jet, #723 Series	784-430000	Pg.206
62.	Nozzle, Accelerator Pump Std.	TM42/11-70	007-487
	Nozzle, Accelerator Pump Optional sizes		Pg.171
63.	O-Ring, A/P Nozzle	VN124.063	007-163
64.	Pilot Jet #25 (#20 Sporty)	VM28/486	Pg.212
65.	Extender, Main Jet (HSR42/45)	TM42/12	007-722
65A.	Extender, Main Jet (HSR48)	TM42/12-1A	007-707
66.	Main Jet# 160 (HSR42)	N100.604-160	004-204
	Main Jet #175 (HSR45)	N100.604-175	004-210
	Main Jet #190 (HSR48)	N100.604-190	004-216
	Main Jet *Optional Sizes	N100.604	Pg.214
67.	O-Ring, Needle Valve	616-33003	007-470
68.	Screw, Needle Valve Retainer	VM13/216	007-174
69.	Needle Valve Assembly (HSR42/45)	786-27001-4.2	007-476
69A.	Needle Valve Assembly (HSR48)	786-27002-1A-4.5	007-708
70.	Float Assembly	859-32027	007-497
71.	Pin, Float	BV26/22	002-107
72.	Screw, Float Pin	C2=0410	007-620
73.	Packing, Float Bowl	616-94028	007-472
74.	Float, Chamber Body	TM42/05	007-500
75.	Hose, Overflow	N122.028	007-630
76.	O-Ring, Drain Plug	VM28/254	002-531
77.	Drain Plug (HSR42/45)	TM32/41	007-646
77A.	Drain Plug (HSR48)	TM32/41-1D	007-713
78.	Screw, Float Bowl	C2=0412-B	007-201
79.	Rod, A/P	TM36/44-1A	007-191
80.	Boot, A/P Rod	TM36/64	007-195
81.	Plunger, A/P	TM36/60	007-198
82.	Spring, A/P	VM14SC13/89	007-200
83.	Rubber Cap, Purge Port (not shown)	N198.063	007-716



## HSR42/45/48 Carburetor Rebuild Kits

Kit contains GENUINE Mikuni parts, all the necessary parts and gaskets to rebuild an HSR carburetor. Includes needle valve assembly, o-rings, gaskets and screws. Sold as a kit.

Mikuni No.	Description	Order No
KHS-016	with 4.2 Needle Vlv. Assy. HSR42/45	002-989
KSR42/45	with 4.5 Needle Vlv. Assy. HSR48	002-982

### Exploded

View No.	Qt	Contents
4.	1	Gasket, Top Cover
5.	1	E-Ring, Jet Needle
6.	1	Washer, Jet Needle
52.	1	O-Ring, Pilot Air
54.	2	O-Ring, Fuel Joint
63.	1	O-Ring, A/P
67.	1	O-Ring, Needle Valve
68.	1	Screw, N.V. Retainer
69.	1	Needle Valve Assy 4.2 (HSR42/45)
69A.	1	Needle Valve Assy 4.5 (HSR48)
73.	1	Packing, Float Bowl
75.	1	Hose, Overflow
76.	1	O-Ring, Drain Plug
78.	4	Screw, Float Bowl (short)
80.	1	Boot, A/P Rod

# Mikuni TM Series Flat Slide



## Mikuni TM Flat Slide Carburetors

Mikuni's original FLAT SLIDE Carburetor. The TM series Carburetors provide significant performance improvements over older round slide Carburetors. Air flows faster and smoother through the TM series venturi due to the flat slide design and the jet blocks which help create smooth bore effect. The high velocity of the air flow means a stronger vacuum at the needle jet providing more precise metering and better throttle response. TM Flat Slide Carburetors are sold pre-jetted, jetting change and throttle valve change. (see listing below) Please specify when ordering.

### TM Flat Slide Standard Jetting Specifications

Carburetor	Main Jet	Main Air Jet	Pilot Jet	Pilot Air Jet	Needle Jet	Jet Needle	Throttle Valve & Cutaway	Mikuni No.	Order No.
TM24	4/042 #130	Fixed	VM22/210 #15	————	454 Series #Q-0	5N13	832-30006 #3.0	TM24-8001	001-017
TM28	4/042 #180	1.8	VM22/210 #15	————	175 Series #P-8	5DP39	832-33001 #2.5	VM28-418	001-023
TM32	4/042 #250	None	VM22/210 #45	————	389 Series #Q-2	5FP17	832-39012 #4.0	TM32-1	001-026
TM34	4/042 #280	None	VM22/210 #50	————	389 Series #Q-2	5FP17	832-39012 #4.0	TM34-2	001-033
TM36	4/042 #280	None	VM22/210 #50	————	389 Series #Q-2	6FJ40	832-43002A #4.0	TM36-2	001-038
TM38 (*47mm)	4/042 #230	None	VM22/210 #22.5	————	389 Series #Q-2	6FJ41	832-43011 #4.0	TM38-85	001-060
TM38 (*43mm)	4/042 #230	None	VM22/210 #22.5	————	389 Series #Q-2	6FJ41	832-43011 #4.0	TM38-86	001-061

\*47mm = Spigot O.D. size, \*43mm = Spigot O.D. size.

### TM Flat Slide with Accelerator Pump Standard Jetting Specifications

TM33	N100.64 #127.5	0.7	VM28/486 #37.5	1.1	640 Series #P-8	5FP96	832-38007 #1.5	TM33-8012	001-032
TM36	N100.64 #130	None	VM28/486 #12.5	1.0	568 Series #P-8	9DZH6-50	TM36/137 #2.0	TM36-68	001-552
TM40 (HS40)	N100.64 #165	Plugged	VM28/486 #17.5	1.1	568 Series #Y-6	9DJY04-96	TM40/81	TM40-6	001-085

### TM Flat Slide Float Height

TM24-8001	TM28-418	TM32-1	TM33-8012 Pumper	TM34-2	TM36-2	TM36-68 Pumper	TM38-85/86	TM40-6 (HS40) Pumper
22 - 24mm	22 - 24mm	17 - 19mm	14mm	17 - 19mm	17 - 19mm	19mm	17 - 19mm	19mm

### Special Set TM Flat Slide Carburetors

Use the following part numbers when ordering for special jetting request.

Carburetor	Jetting Change	Throttle Valve Change
TM24	001-170	————
TM28	001-172	————
TM32	001-176	————
TM34	001-178	————
TM36	001-180	001-181
TM38 with 47mm Spigot O.D.	001-154	001-155
TM38 with 43mm Spigot O.D.	001-152	001-153



### TM Flat Slide Carburetors w/Accelerator Pump TM Power Jet Kit

Use the following part numbers when ordering for special jetting request.

Carburetor	Jetting Change	Throttle Valve Change
TM33	001-187	————
TM36	001-185	————
TM40	001-190	————

The Power Jet Kit is used on 2-stroke engine applications to improve mid-range throttle response and add additional fuel to wide open throttle running conditions. Easily installs on TM series Carburetors. (#80, #100 and #120 sized jets included) Sold as a kit.

Order No. 002-041





## Mikuni TM Pro-Series Flat Slide Carburetors

The TM Pro-Series Carburetors feature proven performance gains with a hand machined venturi area. Testing shows Pro-Series carburetor design will out flow many other factory produced Carburetors by a minimum of 10% or more. This venturi design also provides a higher air speed rate at lower RPM's which results in a much stronger, smoother, wider power band. Sold pre-jetted or to customers jetting request. Please specify when ordering.

Carburetor	Order No.
39mm Pro-Series with 43mm Spigot O.D.	<b>001-194</b>
41mm Pro-Series with 47mm Spigot O.D.	<b>001-196</b>

For replacement parts, use the TM Flat Slide parts list on [page 180-181](#).



## TM Cable Type Starter System Kit

Replaces knob plunger type starter system with a cable type starter system. Sold as a kit. Two Kits available:

**Order No. 002-351**  
Fits the following TM Carburetors: TM32, TM34, TM36, TM38 and 39mm Pro-Series, 41mm Pro-Series. Includes items A - F.

**Order No. 002-353**  
Fits the following TM carburetor: VM28/418 (TM28)  
Includes items A - F.

### Replacement Parts. Sold each.

Description	Mikuni No.	Order No
A. Starter Plunger Top, Rubber Cap	VM26/46	<b>002-061</b>
B. Cable Adjuster	M21/14	<b>002-062</b>
C. Cable Adjuster Locknut	B30/247	<b>002-065</b>
D. Starter Plunger Fitting	VM15/37	<b>002-093</b>
E. Starter Plunger Spring	VM32/69	<b>002-094</b>
F. Starter Plunger (TM32-TM41)	VM15SC4/85	<b>002-095</b>
Starter Plunger (TM28)	VM15SC4/86	<b>007-751</b>

## TM Series Throttle Valves

TM Flat Slide throttle valves. Sold each.  
Note: Throttle Valve for **TM36-68** no longer available.

Carburetor	Size	Mikuni No.	Order No.
TM24 (TM24-8001)	3.0	832-30005	<b>002-951</b>
TM28 (VM28-418)	2.5	832-33001	<b>002-804</b>
TM32 (TM32-1)	4.0	832-39012	<b>002-800</b>
TM34 (TM34-2)	4.0	832-39012	<b>002-800</b>

### Old Style TM 36, TM38 Carburetor with Top Idle Adjuster Rod

TM36 (TM 36-2), TM38 (TM38-1), TM38 (TM38-3)	Size	Mikuni No.	Order No.
	2.5	832-43002	<b>002-734</b>
	3.0	832-43002	<b>002-735</b>
	4.0	832-43002	<b>002-737</b>
	5.0	832-43002	<b>002-739</b>

### New Style TM 38 Carburetor, with Side Idle Adjuster Screw

TM38 (TM38-85), TM38 (TM38-86)	Size	Mikuni No.	Order No.
	2.5	832-43011	<b>007-401</b>
	3.0	832-43011	<b>007-402</b>
	3.5	832-43011	<b>007-403</b>
	4.0	832-43011	<b>007-404</b>
	4.5	832-43011	<b>007-405</b>

TM33 Pumper (TM33-8012)	1.5	832-38007	<b>002-948</b>
TM40 (HS40) Pumper (TM40-6)		TM40/81	<b>007-430</b>



## TM Float Bowl

TM Flat Slide float bowl for TM38-85, TM38-86, TM39 Pro, and TM41 Pro series carburetors. **Drain plug not included**

Mikuni No	Part No.
TM38-138	<b>007-767</b>

# Mikuni TM Series Flat Slide Exploded View

Note: TM Flat Slide Standard Jetting Specifications, see page 90.

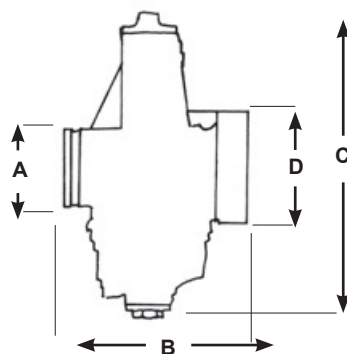
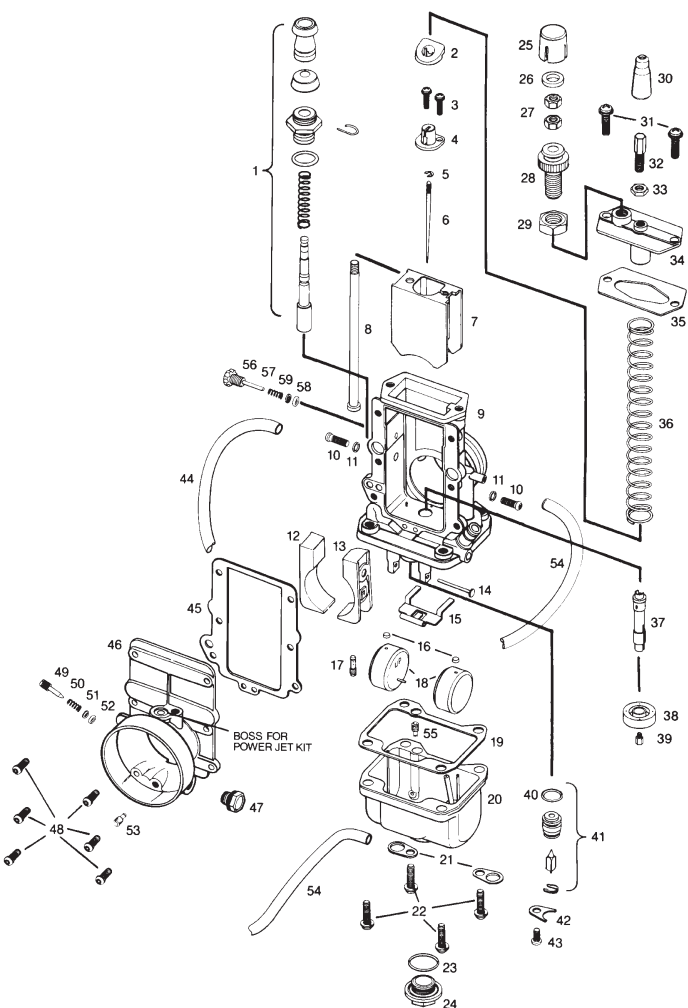

**Float Height**

**See Page 178**

## Carburetor Dimensions

Size (mm)	A	B	C	D	Total Width
TM24-8001	31	75	145	44	76
VM28-418 (TM28)	33	82	135	44	76
TM32-1	40	83	160	58	78
TM34-2	40	83	160	58	78
TM36-2	43	100	170	62	75
TM38-85	47	100	170	62	75
TM38-86	43	100	170	62	75
TM39 Pro-Series	43	100	170	62	75
TM41 Pro-Series	47	100	170	62	75

## TM Replacement Parts

• Lined through part numbers are no longer available.

No.	Description/Application	Mikuni No.	Order No.
1.	Fitting, Starter Plunger		
	VM28-418 (TM28)	VM26/116	<b>002-815</b>
	TM32-1, TM34-2, TM36-2, TM38-1	VM29/47	<b>002-816</b>
	TM38-3, TM38-85, TM38-86	VM29/47	<b>002-816</b>
2.	Nylon Ring		
	TM24-8001	VM24/791A	<b>002-780</b>
	TM28, TM32-34	VM28/1046	<b>002-754</b>
	TM36-2, TM38-1, TM38-3, TM38-85, TM38-86, TM39/41 Pro	VM38/153	<b>002-753</b>
3.	Screw with Lock Washer for Cable Connector		
	TM24-8001	CW2=2608	<b>007-265</b>
	VM28-418 (TM28), TM32-1, TM34-2,	CW2=0310	<b>002-752</b>
	TM36-2, TM38-1, TM38-3	CW2=0310	<b>002-752</b>
4.	Cable Connector		
	TM24-8001	VM24/790	<b>002-758</b>
	TM36-2, TM38-85, TM38-86	VM38/152	<b>002-751</b>
	TM39 and TM41 Pro Series	VM38/152	<b>002-751</b>
5.	E-Ring (Needle Clip) <b>All TM Series</b>	VM20/369	<b>002-083</b>
6.	Jet Needles		<b>Pg.204</b>
7.	Throttle Valves		<b>Pg.179</b>
8.	Idle Rod (TM Carburetors with Top Idle Adjustment)		
	TM36-2, TM38-1, TM38-3	VM38/159	<b>002-732</b>
9.	Mixing Chamber Body		
10.	Screw, Jet Block <b>All TM Series</b>	VM38/132	<b>002-742</b>
11.	Washer <b>All TM Series</b>	VM34/274	<b>002-741</b>
12.	Jet Block, Left - TM38-1, TM38-3	VM38/144	<b>002-710</b>
13.	Jet Block, Right - TM38-1, TM38-3	VM38/145	<b>002-711</b>
14.	Float Pin <b>All TM Series</b>	BV26/22	<b>002-107</b>
	Float Arm		
15.	TM32-1, TM34-2, TM36-2, TM38-1	VM36/15	<b>002-112</b>
	TM38-3, TM38-85, TM38-86	VM36/15	<b>002-112</b>
	TM39 and TM41 Pro Series	VM36/15	<b>002-112</b>
	Cap, Float Guide Pin		
16.	VM28-418 (TM28), TM32-1, TM34-2	VM26/42	<b>002-718</b>
	TM36-2, TM38-1, TM38-3	VM26/42	<b>002-718</b>
17.	Pilot Jet <b>All TM Series</b>	VM22/210	<b>Pg.212</b>
	Float		
18.	TM24-8001	VM24/365	<b>007-255</b>
	VM28-418 (TM28)	VM28/694	<b>007-726</b>
	TM32-1, TM34-2, TM36-2, TM38-1	VM24/236	<b>002-113</b>
	TM38-3	VM24/236	<b>002-113</b>
	TM38-85, TM38-86, TM39/41 Pro <b>RH</b>	859-52020	<b>002-481</b>
	TM38-85, TM38-86, TM39/41 Pro <b>LH</b>	859-52021	<b>002-482</b>
	Gasket, Float Chamber		
19.	TM24-8001	VM20/492	<b>007-250</b>
	VM28-418 (TM28)	VM26/228	<b>007-251</b>
	TM32-1, TM34-2, TM36-2, TM38-1	VM34/374	<b>002-700</b>
	TM38-3, TM38-85, TM38-86	VM34/374	<b>002-700</b>
20.	TM39 and TM41 Pro Series	VM34/374	<b>002-700</b>
	Float Chamber (Bowl) Assembly		
21.	TM36-2, TM38-1, TM38-3	TM32/02-100	<b>002-701</b>
	TM38-85, TM38-86, TM39/41 Pro	TM38/138	<b>007-767</b>
22.	Plate, Hose Retaining		
	VM28-418 (TM28)	VM28/79A	<b>002-204</b>
	TM32-1, TM34-2, TM36-2, TM38-1	VM28/79A	<b>002-204</b>
	TM38-3, TM38-85, TM38-86	VM28/79A	<b>002-204</b>
23.	TM39 and TM41 Pro Series	VM28/79A	<b>002-204</b>
	Screw with Lock Washer		
	TM24-8001	CW2=0416-B	<b>002-615</b>
	VM28-418 (TM28)	CW2=0416	<b>002-823</b>
24.	TM32-1, TM34-2,	CW2=0516	<b>002-373</b>
	TM36-2, TM38-1, TM38-3	CW2=0518	<b>002-719</b>
	TM38-85, TM38-86, TM39/41 Pro	CW2=0518	<b>002-719</b>

## TM Replacement Parts

No.	Description/Application	Mikuni No.	Order No.	No.	Description/Application	Mikuni No.	Order No.
23.	O-Ring			41.	Needle Valve with KV10 O-Ring		
	VM28-418 (TM28)	VM26/227	002-825		(See Page 211 for Optional sizes)		
	TM32-1, TM34-2, TM36-2, TM38-1	VM28/254	002-531		TM24-8001 Std	VM24/557A-1.5	002-842
	TM38-3, TM38-85, TM38-86	VM28/254	002-531		VM28-418 (TM28) Std	VM24/557A-2.5	002-840
	TM39 and TM41 Pro Series	VM28/254	002-531		TM32-1, TM34-2, TM36-2 Std	786-46001-3.3	002-705
24.	Drain Plug				TM38-1, TM38-3 Std	786-46001-3.5	002-707
	VM28-418 (TM28)	VM28/817	002-827		TM38-85, TM38-86, TM39/41 Pro Std	786-46001-3.5	002-707
	TM32-1, TM34-2, TM36-2, TM38-1	VM28/253	002-526	42.	Plate, Needle Valve All TM Series	VM24/560	002-721
	TM38-3, TM38-85, TM38-86	VM28/253	002-526	43.	Screw All TM Series	C2=0406	002-722
	TM39 and TM41 Pro Series	VM28/253	002-526	44.	Vent Hose	VM14/49	002-755
25.	Cap, Idle Adjuster			45.	Gasket, Front Cover		
	TM36-2, TM38-1, TM38-3	VM35/40	002-731		TM24-8001, VM28-418 (TM28)	VM28/1044	002-847
26.	Packing (Rubber)				TM38-85, TM38-86, TM39/41 Pro	VM38/126	002-726
	TM36-2, TM38-1, TM38-3	N138.077	002-730	46.	Front Body, Air Intake		
27.	Nut-TM36-2, TM38-1, TM38-3	N2=04	002-729	47.	Bolt, (Torx Head) TM38-1, TM38-3	BV15/27	
	Idle Adjuster-TM36-2, TM38-1, TM38-3	603-68001	002-728	48.	Screw All TM Series	VM38/133	002-749
29.	Nut-TM36-2, TM38-1, TM38-3	BDC36/35	002-727	49.	Air Screw, Pilot		
30.	Rubber Cap	VM18/228	002-723		TM24-8001, VM28-418 (TM28)	VM20/584	002-850
	TM24, VM28-418 (TM28)	VM26/46	002-061		TM32-1, TM34-2, TM36-2, TM38-1	VM24/672	007-768
	TM32-1, TM34-2, TM36-2	VM18/228	002-723		TM38-3, TM38-85, TM38-86	VM24/672	007-768
	TM38-1, TM38-3	VM18/228	002-723		TM39 and TM41 Pro Series	VM24/672	007-768
	TM38-85, TM38-86	VM34/282	002-452	50.	Spring, Pilot Air Screw All TM Series	M12/46A	002-181
31.	Screw with Lock Washer All TM Series	CW2=0412	002-748	51.	Washer, Pilot Air Screw		
32.	Cable Adjuster				TM32-1, TM34-2, TM36-2, TM38-1	VM12/33	002-856
	VM28-418 (TM28)	M18F/43A	002-062		TM38-3, TM38-85, TM38-86	VM12/33	002-856
	TM32-1, TM34-2, TM36-2, TM38-1	VM36/83	002-724		TM39 and TM41 Pro Series	VM12/33	002-856
	TM38-3, TM38-85, TM38-86	VM36/83	002-724	52.	O-Ring, Pilot Air Screw		
	TM39 and TM41 Pro Series	VM36/83	002-724		TM32-1, TM34-2, TM36-2, TM38-1	N133.037	002-858
33.	Locknut				TM38-3, TM38-85, TM38-86	N133.037	002-858
	VM28-418 (TM28)	B30/247	002-065		TM39 and TM41 Pro Series	N133.037	002-858
	TM32-1, TM34-2, TM36-2, TM38-1	B30/247	002-065	53.	Main Air Jet	BS30/97	Pg.213
	TM38-3, TM38-85, TM38-86	B30/247	002-065	54.	Overflow Hose	VM14/49	002-755
	TM39 and TM41 Pro Series	B30/247	002-065	55.	Starter Jet All TM Series	VM17/1002	Pg.213
34.	Mixing Chamber, Top			56.	Idle Stop Screw		
	TM24-8001	VM24/785	007-765		TM24-8001, VM28-418 (TM28)	603-27002	002-860
	TM36-2, TM38-1, TM38-3	776-19002	002-733		TM32-1, TM34-2	603-16003	002-861
	TM38-85, TM38-86, TM39/41 Pro	776-19001			TM38-85, TM38-86, TM39/41 Pro	603-16003	002-861
35.	Gasket, Top				TM39 and TM41 Pro Series	603-16003	002-861
	TM24-8001	VM24/785	007-765	57.	Spring, Idle Screw		
	VM28-418 (TM28)	VM28/1045	002-830		TM24-8001, VM28-418 (TM28)	VM15/112	002-863
	TM32-1, TM34-2,	VM32/495	007-268		TM32-1, TM34-2	VM24/556	002-864
	TM36-2, TM38-1, TM38-3	VM38/127	002-725		TM38-85, TM38-86, TM39/41 Pro	VM24/556	002-864
	TM38-85, TM38-86, TM39/41 Pro	VM38/127	002-725	58.	O-Ring, Idle Screw		
36.	Spring, Throttle Valve				TM24-8001, VM28-418 (TM28)	VM14/75	002-676
	TM24-8001	730-11003	002-831		TM32-1, TM34-2	BV32/04	002-212
	VM28-418 (TM28)	730-15021	002-832		TM38-85, TM38-86, TM39/41 Pro	BV32/04	002-212
	TM32-1, TM34-2	730-15004	002-833	59.	Washer		
	TM36-2, TM38-1, TM38-3,	730-16003	002-750		TM24-8001, VM28-418 (TM28)	VM14/87	002-866
	TM38-85, TM38-86, TM39/TM41 Pro	730-16003	002-750				
37.	Needle Jet (See page 207 for Optional sizes)						
	TM24-8001	#454 Series Q-0					
	VM28-418 (TM28)	#175 Series P-8					
	TM32-1, TM34-2, TM36-2	#389 Series Q-2					
	TM38-1, TM38-3	#389 Series Q-2					
	TM38-85, TM38-86, TM39/41 Pro	#389 Series Q-2					
38.	Ring, Main Jet						
	TM24-8001	VM28/449	002-664				
	VM28-418 (TM28)	VM28/429	002-836				
	TM32-1, TM34-2, TM36-2	VM34/454	002-837				
	TM38-1, TM38-3	VM34/454	002-837				
	TM38-85, TM38-86, TM39/41 Pro	TM34/36	002-835				
39.	Main Jet All TM Series	4/042	Pg.214				
40.	O-Ring, Needle Valve TM24-28	VM24/559	002-838				
	O-Ring, Needle Valve TM32-41	KV10	002-709				

Mikuni TM Series Carburetors are intended for off-road riding and racing use only. Not legal for use in California or other locations where similar pollution laws may apply.



# Mikuni TM33-8012 Pumper Carb Exploded View

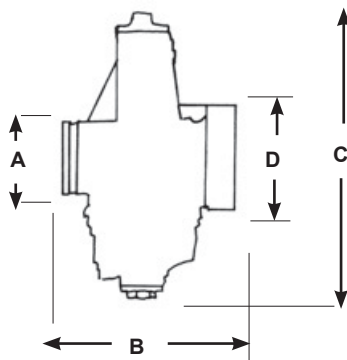
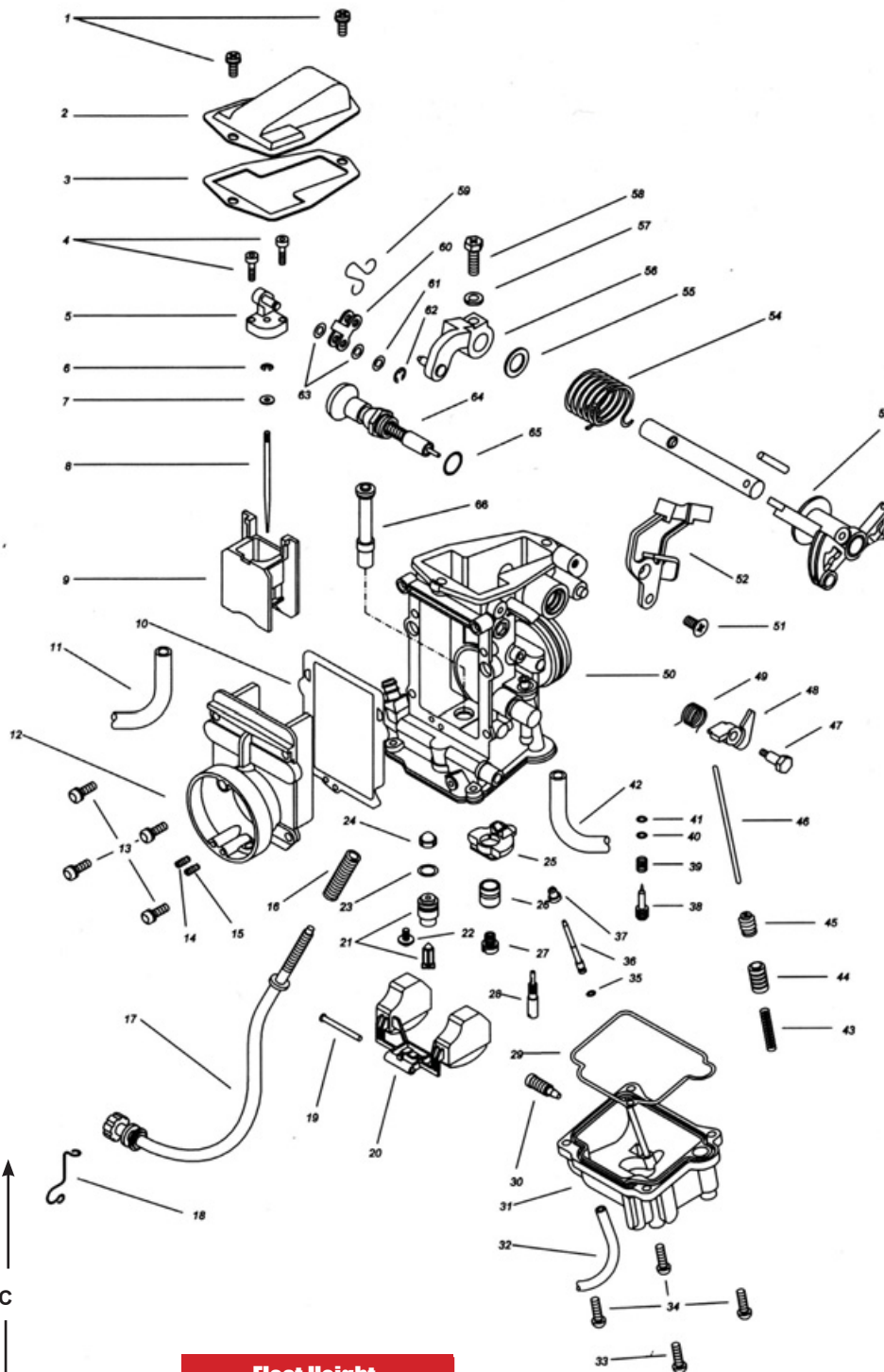

**Float Height**  
**14mm**

## Carburetor Dimensions

Size (mm)	A	B	C	D	Total Width
TM33-8012	40	93	160	50	105

Mikuni TM Series Carburetors are intended for off-road riding and racing use only. Not legal for use in California or other locations where similar pollution laws may apply.

## TM33 Standard Jetting Specifications

Carburetor	Main Jet	Main Air Jet	Pilot Jet	Pilot Air Jet	Needle	Jet Needle	Throttle Valve & Cutaway	Float Height	Mikuni No.	Order No.
TM33	#127.5	0.7	#37.5	1.1	#P-8	#5FP96	832-38007 #1.5	14mm	TM33-8012	001-032

## TM33-8012 Pumper Carb Replacement Parts

• Lined through part numbers are no longer available.

No.	Description	Mikuni No.	Order No.
1.	Screw, Top Cover	CW2=0410	007-626
2.	Top Cover	TM29/16A	_____
3.	Gasket, Top Cover	TM29/17	007-643
4.	Screw, Joint Assy.	793-13001	_____
5.	Joint Assembly	TM29/71	_____
6.	E-Ring	VM20/369	002-083
7.	Packing	VM26/315	007-124
8.	Jet Needle	J8-5FP96-3	007-004
9.	Throttle Valve 1.5	832-38007-1.5	002-948
10.	Gasket, Air Funnel	TM29/62	_____
11.	Hose, Vent	VM34/105	_____
12.	Air Funnel	TM33/32A	_____
13.	Screw, Air Funnel	VM38/133	002-749
14.	Pilot Air Jet	BS30/97-1.1	Pg.213
15.	Main Air Jet	BS30/97-0.7	Pg.213
16.	Spring, Idle Adjuster	730-07008	007-602
17.	Idle Adjuster	TM33/38A	007-651
18.	Clip, Idle Adjuster	N189.169C	_____
19.	Pin, Float	VM30/160	002-605
20.	Float Assembly	859-34003	007-606
21.	Needle Valve Assembly	N133.200-1.8	007-502
22.	Screw, N.V. Holder	VM13/216	007-174
23.	O-Ring, N.V. Assembly	KV/10	002-709
24.	Filter, Needle Valve Seat	VM18/233	002-606
25.	Ring, (nylon), Main Jet	TM33/35A	_____
26.	Ring, (brass), Main Jet	VM38/106	_____
27.	Main Jet #127.5	N100.604	Pg.214
28.	Pilot Jet #37.5	VM28/486	Pg.212
29.	O-Ring, Float Bowl	619-94012	007-508
30.	Drain Screw, Float Bowl	N133.363	007-509
31.	Float Bowl	TM33/77	_____
32.	Hose, Overflow	888-23043-1F	_____
33.	Screw (Long), Float Bowl	C2=0416	007-622
34.	Screw (Short), Float Bowl	C2=0414	007-621
35.	O-Ring, A/Pump Nozzle	N124.063	007-163
36.	Accelerator Pump Nozzle	TM29/24	007-510
37.	Plug, A/Pump Nozzle	TM29/14	007-164
38.	Pilot Screw	N138.192B	007-632
39.	Spring, Pilot Screw	N138.187	007-631
40.	Washer, Pilot Screw	VM12/33	002-856
41.	O-Ring, Pilot Screw	N133.037	002-858
42.	Hose, Vent	888-25029-1E	_____
43.	Spring, A/Pump Plunger	730-04003A	002-867
44.	A/Pump Plunger	TM29/18	007-511
45.	Cap, A/Pump Rod	N150.048	007-512
46.	Rod, A/Pump	TM33/46	_____
47.	Bolt, A/P Lever	B30/397	007-613
48.	Lever, A/P	VM38/212	007-683
49.	Spring, A/P Lever	TM33/47A	_____
50.	Main Body	TM33SS90/01-0	_____
51.	Screw, Throttle Bracket	C5=0510	_____
52.	Bracket, Throttle	TM33/33	007-648
53.	Bell Crank	TM33/44	007-720
54.	Spring, Throttle Return	TM24/21	_____
55.	Packing, Throttle Shaft	B36/95	007-615
56.	Lever, Throttle	VM13/186	_____
57.	Washer, Throttle Lever	W4=05	002-679
58.	Bolt, Throttle Lever	VM28/230	002-519
59.	Spring, Linkage Lever	VM33/4C	002-631
60.	Plate, Linkage Lever	VM33/45	002-630
61.	Washer, Linkage Lever	M10/56	002-632
62.	E-Ring, Linkage Lever	BSW28/70	002-355
63.	Packing, Linkage Lever	B40/10	002-629
64.	Choke Assy.	TM33/49	007-654
65.	O-Ring, Choke Assy.	N138.198	007-160
66.	Needle Jet - 640 Series	784-24111-P-8	Pg.207



## TM33-8012 Needle Valve Assembly

Applications: TM33-8012 Pumper Carburetor and OEM Suzuki DR350 offroad (90-99) with Mikuni TM33 carburetor. Sold each.

Size	Mikuni No.	Order No.
1.5	N133.200-1.5	007-501
1.8	N133.200-1.8	007-502
2.0	N133.200-2.0	007-503
2.3	N133.200-2.3	007-504
O-Ring for Needle Valve Seat	KV/10	002-709
Filter Screen for Needle Valve Seat	VM18/233	002-606

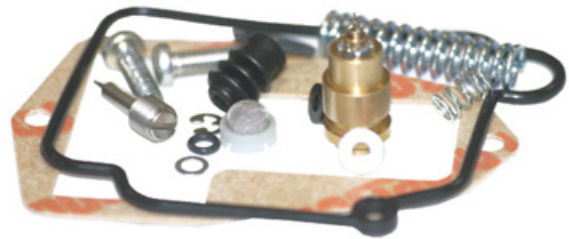

## TM33-8012 Carburetor Rebuild Kit

Kit includes GENUINE Mikuni parts to rebuild the TM33-8012 pumper carburetor. Sold as a kit.

Order No. 025-661



Photo courtesy of theriderskartel.com

# MIKUNI TM36/TM40 (HS40) Pumper Carb Exploded View

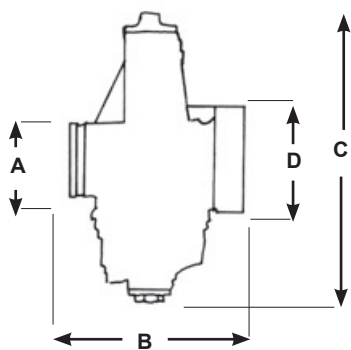
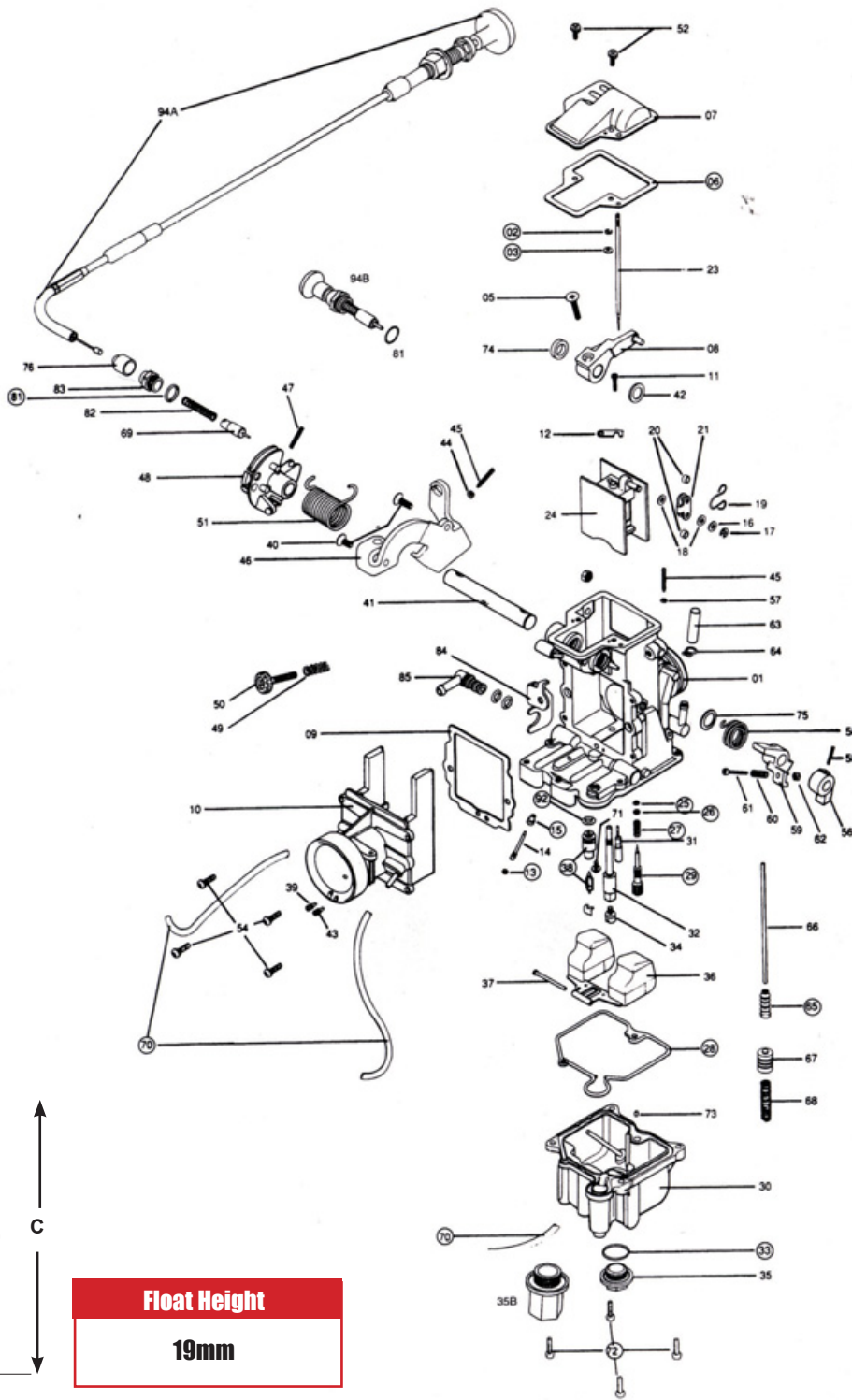

**Float Height**  
**19mm**

## Carburetor Dimensions

Size (mm)	A	B	C	D	Total Width
TM36-68	42	100	176	54	78
TM40-6/HS40	44	100	165	55	—

Mikuni TM Series Carburetors are intended for off-road riding and racing use only. Not legal for use in California or other locations where similar pollution laws may apply.

## TM36 & TM40 (HS40) Standard Jetting Specifications

Carburetor	Main Jet	Main Air Jet	Pilot Jet	Pilot Air Jet	Needle Jet #568 Series	Jet Needle	Throttle Valve & Cutaway	Float Height	Mikuni No.	Order No.
TM36	N100.604 #130	None	VM28/486 #12.5	1.0	#P-8	9DZH6-50	TM36/137 #1.5	19mm	TM36-68	001-552
TM40 (HS40)	N100.604 #165	Plugged	VM28/486 #17.5	1.1	#Y-6	9DJY04-96	TM40/81	19mm	TM40-6	001-085

## TM36/TM40 (HS40) Replacement Parts

• Lined through part numbers are no longer available.

Mikuni Part No. Highlighted in **BOLD RED** are included in rebuild kit.

No.	Description	Mikuni No.	Order No.
1.	Mixing Body	TM4055/01	_____
2.	E-Ring	<b>BS32/126</b>	<b>002-455</b>
3.	Washer	<b>826-03002</b>	<b>007-267</b>
4.	Allen Screw	739-13001	<b>007-123</b>
5.	Flat Head Screw 5x14mm	C5-0514	<b>007-625</b>
6.	Gasket	<b>TM36/39</b>	<b>007-119</b>
7.	Top Cover	TM36/59	_____
8.	Lever Assembly	TM36/57	_____
9.	Gasket, Funnel	TM36/42	<b>007-658</b>
10.	Funnel	TM40/03	_____
11.	Screw, Throttle Valve Plate	C2=0310	_____
12.	Plate, Throttle Valve Lever	TM36/12	_____
13.	O-Ring, Nozzle	<b>N124.063</b>	<b>007-163</b>
14.	Pump Nozzle standard on TM36	TM36/43-03	<b>007-165</b>
	Optional	TM36/43-05	<b>007-166</b>
	Pump Nozzle standard on TM40/HS40	TM36/43-08	<b>007-167</b>
15.	Plug, Nozzle	<b>TM29/14</b>	<b>007-164</b>
16.	Washer	M10/56	<b>002-632</b>
17.	E-Ring	BSW20/70	<b>002-355</b>
18.	Packing	B401/10	<b>002-629</b>
19.	Clip, Throttle Valve Lever	TM27/05A	<b>007-641</b>
20.	Ring, Throttle Valve Lever	TM29/65	_____
21.	Plate, Throttle Valve Lever	TM27/04	_____
23.	Jet Needle ( <b>TM40</b> )	J8-9DJY01-96	<b>007-015</b>
	Jet Needle ( <b>TM36</b> )	9DZH6-50	<b>007-109</b>
24.	Throttle Valve	TM40/81	<b>007-430</b>
25.	O-Ring	<b>N133.037</b>	<b>002-858</b>
26.	Washer	<b>VM12/33</b>	<b>002-856</b>
27.	Spring	<b>N133.206</b>	<b>007-137</b>
28.	O-Ring, Float Bowl	<b>619-94021</b>	<b>007-197</b>
29.	Screw, Pilot Fuel	<b>604-26003</b>	<b>007-138</b>
30.	Float Chamber Body	TM40/12	_____
31.	Pilot Jet	VM28/486	<b>Pg.212</b>
32.	568 Series, <b>See Pg.207</b> for *optional sizes - HS40, TM36, TM40.		
	Needle Jet (HS40) 568 Series Std.	784-13002-Y6	<b>003-666</b>
	Needle Jet (TM36) 568 Series Std.	784-13002-P8	<b>003-656</b>
	Needle Jet (TM40) 568 Series Std.	784-13002-P8	<b>003-656</b>
33.	O-Ring	<b>VM28/254</b>	<b>002-531</b>
34.	Main Jet	N100.604	<b>Pg.214</b>
35.	Drain Plug (TM40) Short	TM32/41	<b>007-646</b>
35B.	Drain Plug (TM36) Long	TM32/41-1C	<b>007-712</b>
36.	Float Assembly	T859-32011	<b>007-141</b>
37.	Pin, Float	VM30/160	<b>002-605</b>
38.	Needle Valve Assembly ( <b>TM36</b> )	786-36011-3.3	<b>007-505</b>
38A.	Needle Valve Assembly ( <b>TM40</b> )	<b>990-786-044-3.8</b>	<b>002-877</b>
39.	Main Air Jet (Plugged)	<b>BS30/97</b>	<b>002-149</b>
40.	Screw 5X12mm	C5-0512-B	_____
41.	Shaft, Throttle	700-15004	_____
42.	Packing, Shaft	_____	_____
43.	Pilot Air Jet	BS30/97	<b>Pg.213</b>
44.	Hexagon Nut	N2=03-B	<b>007-194</b>
45.	Adjust Screw	TM36/48	<b>007-168</b>
46.	Bracket, Bell Crank	TM40/14	_____
47.	Pin, Throttle Bell Crank	N138.019	<b>007-171</b>
48.	Lever Assembly, Bell Crank	TM40/23	<b>007-665</b>
49.	Spring, Idle Adjust ( <b>side idle only</b> )	N150.025	<b>007-633</b>
	Spring, Idle Adjust ( <b>top idle only</b> )	BN38/341	<b>007-491</b>
50.	Idle Adjust ( <b>side idle only</b> )	TM40/91	<b>007-495</b>
	Idle Adjust ( <b>top idle only</b> )	739-55003	<b>007-490</b>
51.	Spring, Throttle Return	TM36/46A	<b>007-204</b>
52.	Screw, Top Cover	CW2-0408	<b>007-175</b>
54.	Screw, Air Funnel	VM38/133	_____
55.	Pin, A/P Locate	BN38/43	<b>007-617</b>
56.	Lever, A/Pump	TM36/18	<b>007-189</b>
57.	O-Ring	B30/205	<b>007-188</b>
58.	Spring, A/Pump	TM40/33	<b>007-668</b>
59.	Lever, A/Pump	TM36/17	<b>007-292</b>
60.	Spring, A/P Adjust	M12F/46A	<b>002-181</b>

No.	Description	Mikuni No.	Order No.
61.	Screw, A/P Adjust	MC-0316	<b>007-193</b>
62.	Hexagon Nut	N3-03-B	<b>007-194</b>
63.	Cap, Vacuum Fitting	N148.013	<b>002-646</b>
64.	Spring Clip, Vacuum Fitting	BVK28/128	_____
65.	Cap, A/P Rubber	<b>TM36/64</b>	<b>007-195</b>
66.	Rod, A/Pump	TM36/44	<b>007-192</b>
67.	Plunger	TM36/60	<b>007-198</b>
68.	Spring, A/Pump	VM14SC13/89	<b>007-200</b>
69.	Plunger, Starter	VM38/148	<b>007-203</b>
70.	Hose	<b>888-23026</b>	<b>007-608</b>
71.	Screw, Needle Valve Holder	VM13/216	<b>007-174</b>
72.	Screw, Float Bowl	<b>C2-0412-B</b>	<b>007-201</b>
73.	Starter Jet	VM17/1002	<b>Pg.213</b>
74.	Packing, Shaft	VM28/174	_____
75.	Ring, A/P Spring	E204040	<b>007-628</b>
76.	Cap, Starter Cable	VM12/43	<b>007-676</b>
81.	O-Ring	<b>N138.198</b>	<b>007-160</b>
82.	Spring Starter	VM16/42	<b>002-671</b>
83.	Guide Holder	640-12001	<b>007-161</b>
84.	Plate, Fuel Inlet	TM40/26	_____
85.	Inlet, Fuel	TM40/27	<b>007-667</b>
92.	O-Ring, Needle Valve	<b>KV/10</b>	<b>002-709</b>
94.	Choke Cable Assembly	990-662-001	<b>007-209</b>
94B.	Choke Knob	TM40/07	<b>007-684</b>



## TM36/TM40 (HS40) Carburetor Rebuild Kits

Kits contain GENUINE Mikuni parts, all the necessary parts and gaskets to rebuild the TM36/TM40 (HS40) carburetor. Includes needle valve assembly, o-rings, gaskets and screws. Sold as a kit.

Mikuni No.	Description	Order No
	with 3.5 Needle Vlv. Assy. TM36	<b>002-985</b>
KHS-001	with 3.8 Needle Vlv. Assy. TM40 (HS40)	<b>002-940</b>

### Exploded

View No.	Qt	Contents
2	1	E-Ring, Jet Needle
3	1	Washer, Jet Needle
6	1	Gasket, Top Cover
13	1	O-Ring, A/P Nozzle
15	1	Plug, A/P Nozzle
25	1	O-Ring, Fuel Screw
26	1	Washer, Fuel Screw
27	1	Spring, Fuel Screw
28	1	O-Ring, Float Bowl
29	1	Screw, Pilot Fuel
33	1	O-Ring, Drain Plug
38	1	Needle Valve Assy #3.3 (TM36)
38A	1	Needle Valve Assy #3.8 (HS40/TM40)
39	1	Main Air Jet (Plugged)
65	1	Cap, A/P Rubber
70	1	Hose
72	4	Screw, Float Bowl
81	1	O-Ring, Starter
92	1	O-Ring, Needle Valve

See next page for TM36/TM40 (HS40) Parts & Accessories

VINTAGE  
INTAKE  
ENGINE  
SUSPENSION  
CONTROL  
ELECTRICAL  
CHEMICAL  
TOOLS  
WATERCRAFT



## TM40 (HS40) Rubber Flange Adapters Sold each.

Genuine Mikuni rubber flange adapters for Evolution or Sportster/ Shovelhead Kit.

Description	Mikuni No.	Order No.
HS40-6K	I-VM36-200-1	<b>002-054</b>
HS40-7K	I-VM38-200-1	<b>002-055</b>
HS40 All	KHS-004	<b>002-986</b>



## TM40 (HS40) K&N Air Filters

The replacement air filters for the HS Series are K&N Air Filters made especially for the HS Series Carburetors.

Description	Mikuni No.	Order No.
Chrome Air Cleaner Cover	RS36/24-200	<b>007-215</b>
Replacement Element Only	RS36/25-200	<b>007-216</b>



## HS40 Carb Adapter for 1990 H-D® Models with Standard Carb/Spigot Adapter Rings

To fit HS40-6K Evolution Carb Kit to 1990-on Harley Davidson® models equipped with the Keihin 40mm CV carb. Sold each.

Description	Mikuni No.	Order No.
EVO Adapter Ring	MK-413	<b>005-095</b>



## TM40 (HS40) Throttle Cables Sold each.

Replacement cables for HS Series Kits Sold each.

Description	Mikuni No.	Order No.
Throttle Cable (Pull)	RS36/34-A	<b>007-210</b>
Idle Cable (Push)	RS36/35-A	<b>007-211</b>

**(cables available in +6" and 4" shorter)**



## Jet Needles TM36

**No.23 in exploded view on page 184, Parts list page 185.**

Mikuni No.	Diameter	Order No.
#9DZH06-50 (Std)		<b>007-109</b>
#9EBY01-51	2.51	Leaner <b>007-106</b>
#9EBY01-50	2.50	Richer <b>007-105</b>

When using these Jet Needles **007-105** & **007-106**, the use of a larger pilot jet may be required.



## Jet Needles TM40 (HS40)

**No.23 in exploded view on page 184, Parts list page 185.**

Mikuni No.	Diameter	Order No.
#9DJY01	2.97	Leaner <b>007-015</b>
#9DJY03	2.96	<b>007-017</b>
#9DJY04 (Std)	2.96	<b>007-018</b>
#9DJY02	2.95	Richer <b>007-016</b>



## Mikuni TMX Carburetors

The TMX series (early) carburetors feature a flat slide design in a smooth bore venturi to provide improved throttle response and wider powerband. Later series (late) TMX feature a flat/oval type slide. Light weight and compact body. TMX series carburetors are available in 35mm bore size for 125cc race engines and 38mm bore sizes for 250cc race engines.

## Special Set TMX Flat Slide Carburetors

Use the following part numbers when ordering for special jetting request.

Carburetor	Mikuni Reference	Jetting Change
TMX35	TMX35-1	001-182
TMX38	TMX38-18	001-189
TMX38	TMX38-27	001-184



Early Style TMX

## TMX Flat Slide Carburetors (Early Style) Standard Jetting

Carburetor	Main Jet	Pilot Jet	Jet Needle	Throttle Valve Cutaway	Needle Valve Set	Float Height	Mikuni No.	Order No.
TMX35-1	4/042 #350	VM22/210 #20	6EN11-53	999-832-014-6.0	786-36004-3.5	20mm	TMX35-1	001-034
TMX38-18	4/042 #370	VM22/210 #20	6EJ12-55	999-832-014-3.5	786-36004-3.5	20mm	TMX38-18	001-076
TMX38-27	4/042 #370	VM22/210 #20	6EJ12-55	999-832-014-3.5	786-36004-3.5	20mm	TMX38-27	001-077



## TMX Series Throttle Valves (Early Style)

Throttle valves for TMX35 and TMX38. Sold each.

Cutaway	Mikuni No.	Order No.
3.0	999-832-014-3.0	002-472
3.5	999-832-014-3.5	002-473
4.0	999-832-014-4.0	002-476
5.0	999-832-014-5.0	002-474
6.0	999-832-014-6.0	002-475

## TMS Throttle Valves

Applications: TMS. Sold each.

Engine	Inlet Hole	Outlet Hole	Mikuni No.	Order No.
250cc	3.0mm	2.0mm	999-832-017 "1G"	007-410
125cc	2.0mm	1.4mm	999-832-017 "1H"	007-411

# Mikuni TMS/TMX Series (Early Style) Exploded View

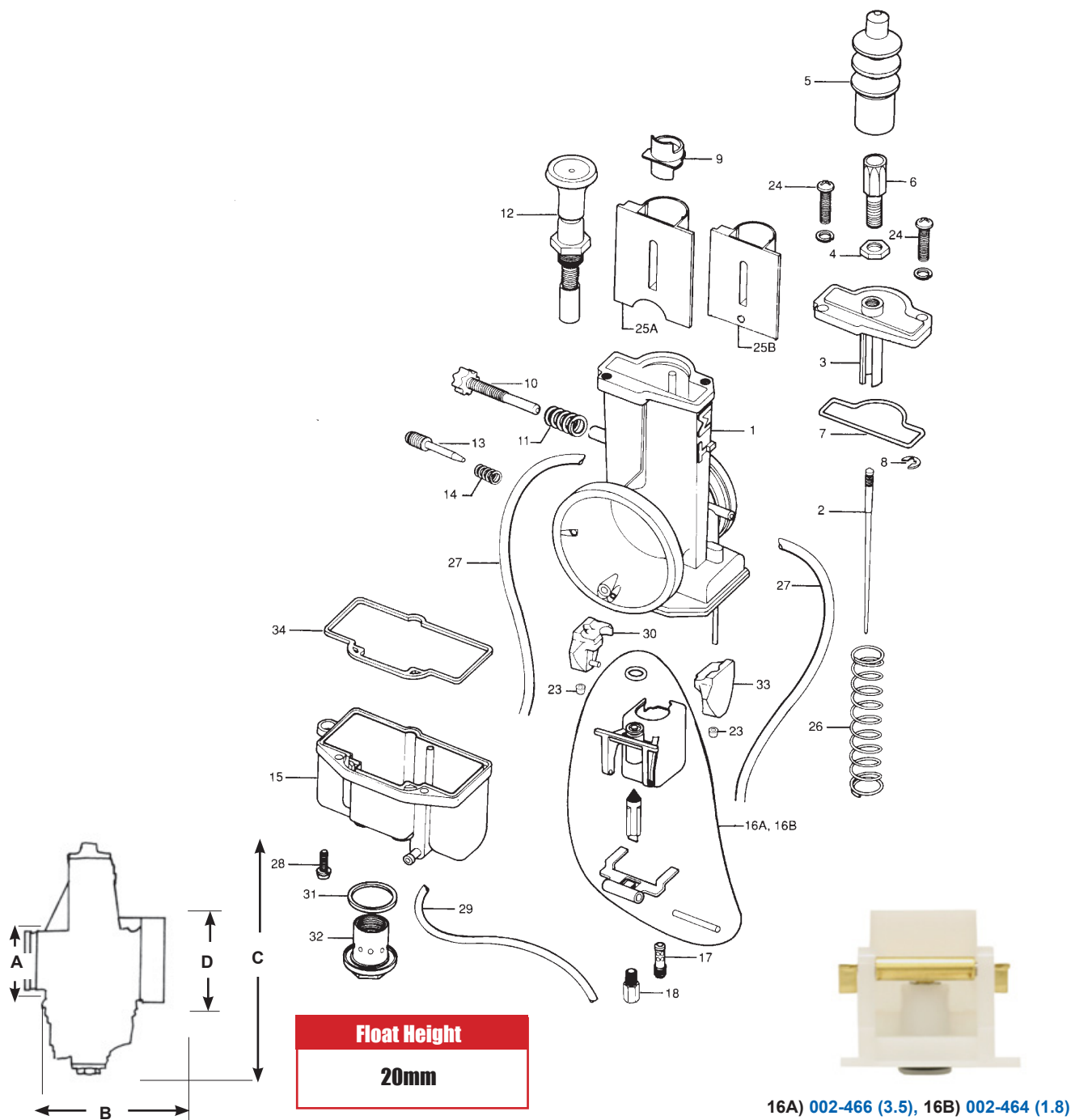

**Float Height**  
**20mm**

16A) 002-466 (3.5), 16B) 002-464 (1.8)

## Carburetor Dimensions

Size (mm)	A	B	C	D	Total Width
TMX35-1	40	76	164	62	76
TMX38-18	47	76	164	62	76
TMX38-27	44	76	164	62	76
TMS38-77	44	76	164	62	76
TMS38-78	47	76	164	62	76

Note: TMS carburetor is no longer in production.

Mikuni TMX Series Carburetors are intended for off-road riding and racing use only. Not legal for use in California or other locations where similar pollution laws may apply.

## TMX Flat Slide Carburetors (Early Style) Standard Jetting

Carburetor	Main Jet	Pilot Jet	Jet Needle	Throttle Valve Cutaway	Needle Valve Set	Float Height	Mikuni No.	Order No.
TMX35-1	4/042 #350	VM22/210 #20	6EN11-53	9998-832-014-6.0	786-36004-3.5	20mm	TMX35-1	001-034
TMX38-18	4/042 #370	VM22/210 #20	6EJ12-55	9998-832-014-3.5	786-36004-3.5	20mm	TMX38-18	001-076
TMX38-27	4/042 #370	VM22/210 #20	6EJ12-55	9998-832-014-3.5	786-36004-3.5	20mm	TMX38-27	001-077



## TMS/TMX Early Style Replacement Parts

• Lined through part numbers are no longer available.

Mikuni Part No. Highlighted in **BOLD RED** are included in rebuild kit.

Note: TMS carburetor is no longer in production.

No.	Description	Mikuni No.	Order No.
1.	Mixing Body, Carb	TMS38SS11	_____
2.	Jet Needle. See chart at bottom of page.		
	Jet Needle (TMX35)	6EN11	See Chart
	Jet Needle (TMX38)	6EJ12	See Chart
	Jet Needle (TMS38) for 125cc	6GDY12	See Chart
	Jet Needle (TMS38) for 250cc	6DGY04	See Chart
3.	Cover, Carb Top	776-19014	002-451
4.	Lock Nut, Adjuster	B30/247	002-065
5.	Cap, Rubber	VM34/282	002-452
6.	Adjuster, Cable	VM30/77	002-453
7.	O-Ring, Top Cover	616-93009	002-454
8.	E-Ring, Needle Clip	BS32/126	002-455
9.	Ring, Retaining	TM38/54	002-456
10.	Adjuster, Idle Stop	603-25008	002-457
11.	Spring, Idle Adjust	N110.209	002-655
12.	Plunger, Starter Assy.	VM29/47	002-816
13.	Screw, Air Adjuster	603-36002	002-459
14.	Spring, Air Screw	VM15/112	002-863
15.	Chamber, Float Bowl	TM38/48	002-461
16A.	Valve Seat, Needle Assembly.	786-36004 (3.5)	002-466
16B.	Valve Seat, Needle Assembly.	786-36004-A (1.8)	002-464
17.	Pilot Jet	VM22/210	Pg.212
18.	Main Jet	4/042	Pg.214
23.	Cap, Float Retainer	VM26/42	002-718
24.	Screw, Top Cover 4 x 12mm	CW2=0412	002-748
25A.	Throttle Valve <b>TMX</b> (see chart)	999-832-014	Pg.197
25B.	Throttle Valve <b>TMS</b> (see chart)	999-832-017	Pg.197
26.	Spring, Throttle Valve	730-13019	002-477
27.	Hose, Vent (Black)	888-24011	002-478
28.	Screw, Float Bowl 3 x 8mm	CW2=308	002-479
29.	Hose, Overflow	888-23022	002-480
30.	Float, Left Side	859-52021	002-482
31.	O-Ring, Drain Plug	BN042/64	002-602
32.	Drain Plug	TM38/44	002-483
33.	Float, Right Side	859-52020	002-481
34.	Gasket, Float Bowl	TM38/52	002-484
	<b>*Not shown in exploded view.</b>		
	*Needle Valve only	788-26005	002-469



## TMS/TMX Early Style Carburetor Rebuild Kit

Applications: TMS38, early style TMX35, TMX38. Kit includes GENUINE Mikuni parts to rebuild the TMS and early style TMX Carburetors. Sold as a kit. Two kits available:

With 3.5 Needle Assembly Valve Seat.	007-950
With 1.8 Needle Assembly Valve Seat.	007-951

### Exploded

View No.	Qt	Contents
5.	1	Cap, Rubber
7.	1	O-Ring, Top Cover
8.	1	E-Ring, Needle Clip
9.	1	Ring, Retaining
13.	1	Screw, Idle Adjuster
14.	1	Spring, Air Screw
16A.	1	Valve Seat, Needle Assembly. (in Rebuild Kit 007-950)
16B.	1	Valve Seat, Needle Assembly. (in Rebuild Kit 007-951)
23.	2	Cap, Float Retainer
24.	2	Screw, Top Cover 4 x12mm
28.	1	Screw, Float Bowl 3 x 8mm
31.	1	O-Ring, Drain Plug
34.	1	Gasket, Float Bow

## TMX Series Jet Needles

Jet Needles for early style TMX35 and TMX38. Sold each.

Application	Jet Needle	Jet Needle Diameter	Order No.	Air/Fuel Ratio
TMX35	6EN11-58	2.58	007-056	Leaner
TMX35	6EN11-57	2.57	007-055	↑
TMX35	6EN11-56	2.56	007-054	↑
TMX35	6EN11-55	2.55	007-053	↑
TMX35	6EN11-54	2.54	007-052	↑
TMX35	6EN11-53	2.53	007-051	↓
TMX35	6EN11-52	2.52	007-050	Richer
TMX38	6EJ12-60	2.60	007-077	Leaner
TMX38	6EJ12-59	2.59	007-076	↑
TMX38	6EJ12-58	2.58	007-075	↑
TMX38	6EJ12-57	2.57	007-074	↑
TMX38	6EJ12-56	2.56	007-073	↑
TMX38	6EJ12-55	2.55	007-072	↓
TMX38	6EJ12-54	2.54	007-071	↓
TMX38	6EJ12-53	2.53	007-070	Richer

## TMS Series Jet Needles

Jet Needles for early style TMS38. Sold each.

Application	Jet Needle	Jet Needle Diameter	Order No.	Air/Fuel Ratio
TMS38-77, 78 125cc	6GDY12-59	2.59	007-088	Leaner
TMS38-77, 78 125cc	6GDY12-58	2.58	007-087	↑
TMS38-77, 78 125cc	6GDY12-57	2.57	007-086	↓
TMS38-77, 78 125cc	6GDY12-56	2.56	007-085	Richer
TMS38-77, 78 250cc	6DGY04-60	2.60	007-048	Leaner
TMS38-77, 78 250cc	6DGY04-59	2.59	007-047	↑
TMS38-77, 78 250cc	6DGY04-58	2.58	007-046	↑
TMS38-77, 78 250cc	6DGY04-57	2.57	007-045	↑
TMS38-77, 78 250cc	6DGY04-56	2.56	007-044	↓
TMS38-77, 78 250cc	6DGY04-55	2.55	007-043	↓
TMS38-77, 78 250cc	6DGY04-54	2.54	007-042	Richer

# Mikuni TMX Series (Late Style) Exploded View

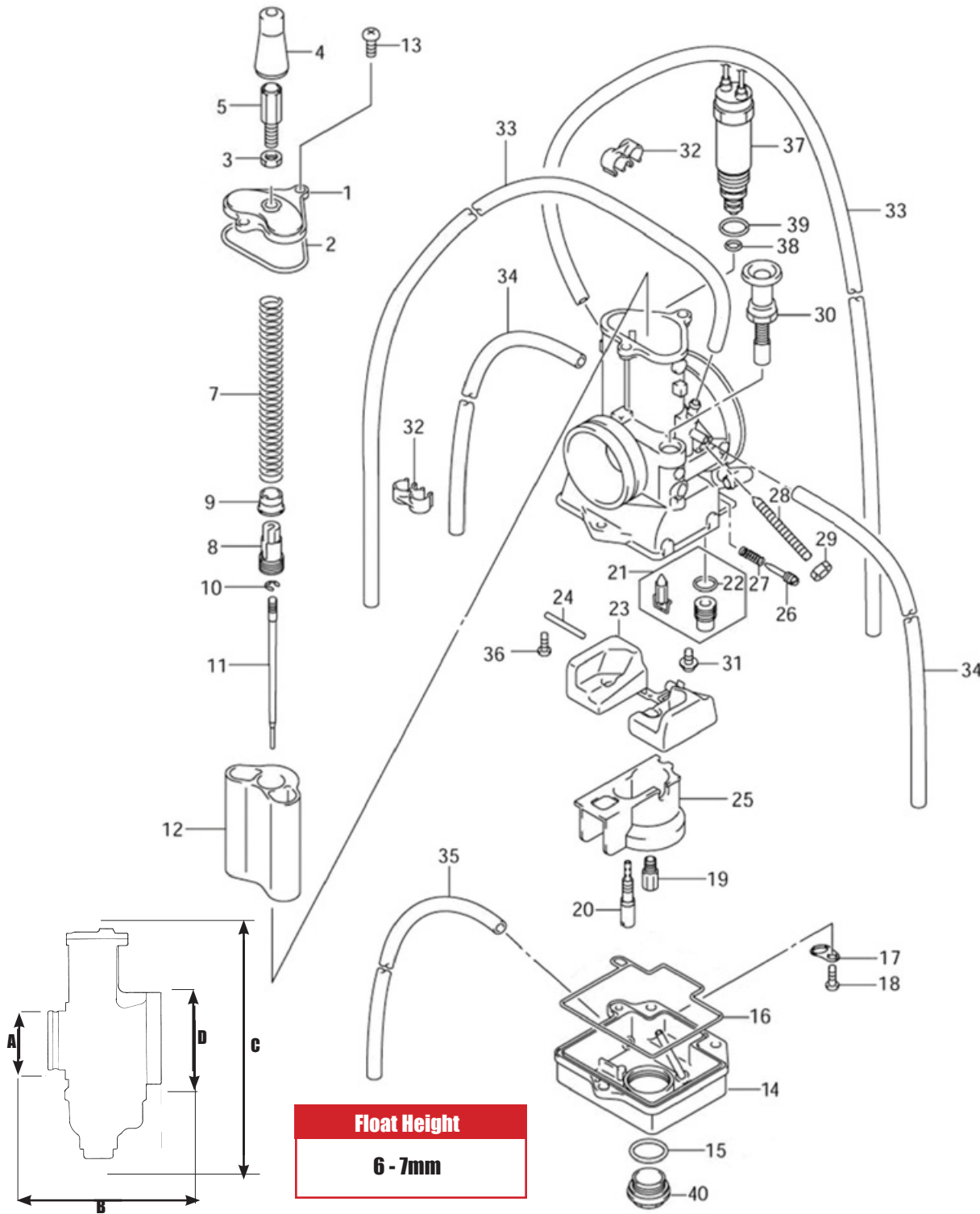

**Float Height**  
**6 - 7mm**

## Carburetor Dimensions

Size (mm)	A	B	C	D	Total Width
TMX38-2	46	75	152.5	62	86
TMX38-5	46	70	152.5	62	86

Mikuni TMX Series Carburetors are intended for off-road riding and racing use only. Not legal for use in California or other locations where similar pollution laws may apply.

## TMX Oval Slide Carburetors (Late Style) Standard Jetting

Carb Size	Main Jet	Pilot Jet	Needle Jet	Jet Needle	Throttle Valve Cutaway	Needle Valve Set	Float Height	Mikuni No.	Order No.
TMX38	4/042 #310	N224.103 #20	6BEG18-68	832-42016-5.0	832-42016	786-36011-3.8	6-7mm	TMX38-2	_____
TMX38	4/042 #640	N224.103 #30	6BEG2-60	832-42016-5.0	832-42016	786-26004-1.5	6-7mm	TMX38-5	_____

## TMX Later Style Replacement Parts

• Lined through part numbers are not available.

No.	Description	Mikuni No.	Order No. TMX38-2	Order No. TMX38-5
1.	Cover, Carb Top	776-19043	_____	_____
	Cover, Carb Top	TMR38/18	_____	_____
2.	O-Ring, Top Cap	616-93055	<b>007-754</b>	<b>007-754</b>
3.	Lock Nut, Adjuster	B30/247	<b>002-065</b>	<b>002-065</b>
4.	Rubber Cap	VM34/282	<b>002-452</b>	_____
	Rubber Cap	30BIC/84	_____	_____
5.	Adjuster Screw (Cable)	VM30/77	<b>002-453</b>	_____
	Adjuster Screw (Cable)	VM20/683	_____	_____
6.	Needle Jet (not shown)	press fit - N/A	_____	_____
	Needle Jet	784-13005	_____	_____
		(633 Series)	_____	_____
7.	Spring, Throttle Valve	730-12040	_____	_____
8.	Needle Retainer	TMR36/01	_____	_____
9.	Guide	TMR38/33	_____	_____
10.	E-Ring	TM32/90	_____	_____
11.	Jet Needle	6BEG18-68-3	_____	_____
	Jet Needle	6EG2-60-3	_____	_____
12.	Throttle Valve (oval type)	832-42016-XX	_____	_____
13.	Screw 4 x 14mm	C2=0414	<b>007-621</b>	<b>007-621</b>
14.	Float Bowl	TMR38/11-1A	_____	_____
	Float Bowl	TMR38/11-1C	_____	_____
15.	O-Ring, Drain Plug	VM26/227	<b>002-825</b>	<b>002-825</b>
16.	Gasket, Float Bowl	616-93054	<b>007-753</b>	<b>007-753</b>
	Gasket, Float Bowl	616-93057	_____	_____
17.	Clamp Plate for Float Bowl Vent Hose	_____	_____	_____
18.	Screw only 5 x 14mm	C2=0514	_____	_____
19.	Main Jet	4/042	<b>Pg.214</b>	<b>Pg.214</b>
20.	Pilot Jet	N224.103	<b>Pg.213</b>	<b>Pg.213</b>
21.	Needle Valve Assembly	786-36011-(3.8)	<b>002-877</b>	_____
		786-26004-(1.5)	_____	_____
22.	O-Ring, Needle Valve Assy	KV/10	<b>002-709</b>	<b>002-709</b>
23.	Float	859-32035	_____	_____
	Float	859-32039	_____	_____
24.	Float Pin	VM20/315	<b>002-470</b>	<b>002-470</b>
25.	Ring, Main Jet	TMR38/09	_____	_____
26.	Screw, Air Adjuster	603-36002	<b>002-459</b>	<b>002-459</b>
27.	Spring, Air Screw	VM15/112	<b>002-863</b>	<b>002-863</b>
28.	Screw, Idle Stop	TMR36/09	_____	_____
29.	Nut, Idle Stop Screw	N138050	_____	_____
30.	Choke Assy	VM29/47	<b>002-816</b> (see 30A-30F)	_____
30A.	Plunger	VM15SC4/85	_____	<b>002-095</b>
30B.	Spring	VM16/42	_____	_____
30C.	Starter Plunger Fitting	M15/37	_____	<b>002-093</b>
30D.	Rubber Cap	30BIC/84	_____	_____
30E.	Adjust Screw	M21/14	_____	_____
30F.	Nut	B30/247	_____	<b>002-065</b>
31.	Screw, Needle Valve Holder	VM13/216	<b>007-174</b>	<b>007-174</b>
32.	Clamp,Vent Hose	_____	_____	_____
33.	Hose, Vent	888-23041	_____	_____
	Hose, Vent	888-23045-37	_____	_____
34.	Hose, Vent	888-23041	_____	_____
35.	Hose, Float Bowl Overflow	VM20/594	_____	_____
36.	Screw only, 4 x 8mm	C2=0408	_____	_____
37.	Solenoid	TM38/87-1A	_____	_____
38.	O-Ring, Solenoid	BV32/04	<b>002-212</b>	<b>002-212</b>
39.	O-Ring, Solenoid	BV30/40	<b>002-617</b>	<b>002-617</b>
40.	Drain Plug	894-80001	_____	_____



### Honda OEM TMX Throttle Valve

Flat throttle valve for Honda CR250R (01-03). Fits Honda OEM TMX38 carburetor only. Sold each.

Cutaway	Mikuni No.	Order No.
5.0.	832-41018-5.0	<b>007-415</b>



### Honda OEM 633 Series Nozzle (Needle Jet)

Nozzles for Honda CR125R (00-01), CR250R (2001). Optional for Kawasaki KX125L3. Sold each.

Size	Mikuni No.	Order No.	
S-4	784-13005	<b>003-720</b>	Leaner
S-7	784-13005	<b>003-722</b>	
S-8	784-13005	<b>003-723</b>	
S-9	784-13005	<b>003-724</b>	Richer



### OEM Needle Valve Assembly

Includes needle valve, clip, seat and o-ring. OEM Replacement for models using late style Mikuni TMX36 and TMX38 carburetors. Sold each.

Mfg.	Model	Year	OEM Reference & Size	Order No.
Honda	CR125R	01-07	16011-KZ4-A92 (3.8)	<b>002-877</b>
Husqvarna	CR125 w/TMX	_____	_____	<b>002-877</b>
Kawasaki	KX125	01-05	16030-1096 (3.8)	<b>002-877</b>
Suzuki	RM125	00-07	13370-36F00 (3.3)	<b>007-954</b>
Yamaha	YZ125	95-13	4PE-14107-38-00 (3.8)	<b>002-877</b>



## VM Series Round Slide Single Carburetors

These are the most popular high performance singles carburetor in the sport of motorcycling. Mikuni's VM series round slide single Carburetors have proven themselves as the performance standard for use in any single cylinder motorcycle or ATV applications for motocross, enduro and trail riding, to flat track racing and road racing on both 2-stroke and 4-stroke engines.

Performance features for the VM Series Carburetors include a large selection of bore sizes for increased fuel mixture flow to match engine modifications. The VM Series offers a wide range of tuning components to allow precise fuel mixture metering in any application, at any throttle setting, under any riding condition. VM Series Carburetors are sold pre-jetted. (see Standard Jetting Specifications below) Special Jetting also available, see next page.

**Please Note:** Changes and jetting modifications are for use only on racing machines or similar off-road vehicles where pollution laws are not in effect. Not legal for vehicles operated on public highways in the State of California or other areas where similar pollution laws may apply.

### "Left" Idle Screw Standard Jetting Specifications

Carb Size	Main Jet	Pilot Jet	Needle Jet	Jet Needle	Throttle Valve Cutaway	Air Jet	Needle Valve Set	Float Height	Mikuni No.	Order No.
VM16	N100.604 #70	VM22/210 #25	#165 D-8	#3DJ3	2.5	None	VM15/172-1.8	24-26mm	VM16-519	001-000
VM18	4/042 #80	VM22/210 #30	#145 O-0	#4F18	VM18/158 1.0	None	VM15/172-1.5	20-22mm	VM18-144	001-001
VM20	4/042 #180	M28/1001 #22.5	#239 O-6	#4J13	VM20/491 2.0	0.5 Fixed	VM15/172-1.5	20-22mm	VM20-273	001-005
VM22	4/042 #100	VM22/210 #30	#257 N-8	#4D20	VM26/21 2.0	None	VM26/26-2.0	24-26mm	VM22-133	001-007
VM26	4/042 #190	VM22/210 #60	#182 N-8	#5F21	VM28/56 2.0	BS30/97 0.5	VM26/26-2.5	15-17mm	VM26-8074	001-020
VM26	4/042 #190	M28/1001 #22.5	#332 O-0	#5E75	VM24/361 1.5	Fixed	VM26/26-2.5	22-24mm	VM26-606	001-021
VM28	4/042 #200	VM22/210 #60	#169 N8	#5F21	VM28/56 2.5	BS30/97 0.5	VM26/26-2.5	22-24mm	VM28/49	001-022
VM30	4/042 #250	VM22/210 #40	#159 P-5	#6F5	VM34/110 2.5	BS30/97 2.0	VM34/39-3.3	22-24mm	VM30-83	001-024
VM32	4/042 #200	VM22/210 #35	#159 Q-6	#6DP17	VM34/110 3.0	BS30/97 2.0	VM34/39-3.3	22-24mm	VM32-33	001-028
VM34	4/042 #260	VM22/210 #35	#159 Q-2	#6DH4	VM34/110 2.5	BS30/97 2.0	VM34/39-3.3	22-24mm	VM34-168	001-030
VM36	4/042 #310	VM22/210 #35	#159 Q-5	#6FJ6	VM36/36-2.5	BS30/97 2.0	VM34/39-3.3	17-19mm	VM36-4	001-035
VM44	4/042 #310	VM22/210 #35	#224 AA-5	#7F7	VM44/23-2.5	BS30/97 0.5	VM34/39-3.3	17-19mm	VM44-3	001-048

### "Right" Idle Screw Standard Jetting Specifications

Carb Size	Main Jet	Pilot Jet	Needle Jet	Jet Needle	Throttle Valve Cutaway	Air Jet	Needle Valve Set	Float Height	Mikuni No.	Order No.
VM24	4/042 #210	VM22/210 #40	#864 N-8	#5I14	1.5	None	786-15005-2.5		VM24-512	001-018
VM32	4/042 #200	VM22/210 #35	#159 Q-6	#6DP17	VM32/65 3.0	BS30/97 2.0	VM34/39-3.3	22-24mm	VM32-193	001-051
VM34	4/042 #260	VM22/210 #35	#159 Q-2	#6DH4	VM32/65 2.5	BS30/97 2.0	VM34/39-3.3	22-24mm	VM34-275	001-052
VM38	4/042 #330	VM22/210 #30	#166 Q-2	#6DP1	VM38/24 2.5	BS30/97 0.5	VM34/39-3.3	17-19mm	VM38-9	001-040

### Snowmobile Single Carburetor Standard Jetting Specifications

Carb Size	Main Jet	Pilot Jet	Needle Jet	Jet Needle	Throttle Valve Cutaway	Air Jet	Needle Valve Set	Float Height	Mikuni No.	Order No.
VM34	4/042 #330	VM22/210 #30	#159 Q-0	#6DH3	VM34/110 2.5	BS30/97 2.0	VM34/39-1.5	22-24mm	VM34-39	001-029
VM38	4/042 #360	VM22/210 #40	#166 Q-0	#6DH3	VM38/24 2.5	2.5 Body	VM28/163-1.5	22-24mm	VM38-21	001-041
VM44	4/042 #540	VM22/210 #35	#224 AA-5	#7DH2	VM40/02 1.5	BS30/97 0.7	VM28/163-1.5	17-19mm	VM44-7	001-047

(aluminum)

## Sudco Special Jetting for VM Series Round Slide Single Carburetors

Sudco can also "Special Jet" any Mikuni VM series carburetor for your particular application. Below is the information you will need to provide our Carburetor Technician Specialist's so they can provide you with the correct carburetor and jetting.

1. Carburetor Size (mm)
2. Type of Carburetor: Clamp-on, Spigot Mount, Flange Mount, Flat-Slide, etc.
3. Application: Model, Year and cubic centimeters. (125cc, 250cc, etc.)
4. Modifications done to engine: Explain in detail, example - big bore kit with cc change, ported cylinder, etc.
5. Type of use for motorcycle: Street, Drag Racing, Road Race, Motocross, Offroad, Enduro, etc.
6. Type of Fuel used
7. Climate conditions: sea level, area of use, high altitude, etc.

Most popular settings are already available. However, if you have modifications done, it is necessary to follow the guidelines to insure receiving the proper jetting at the closest range.

Use the following part numbers when ordering for special jetting or throttle valve change.

Left Idle Screw Carburetor	Jetting Change	Throttle Valve Change	Right Idle Screw Carburetor	Jetting Change	Throttle Valve Change
VM20	001-150	001-151	VM20	_____	_____
VM22	001-138	001-139	VM20	_____	_____
VM26	001-110	001-111	VM26	_____	_____
VM30	001-114	001-115	VM30	_____	_____
VM32	001-116	001-117	VM32	001-166	001-167
VM34	001-160	001-161	VM34	001-168	001-169
VM36	001-122	001-123	VM36	_____	_____
VM38	_____	_____	VM38	001-126	001-127
VM44	001-132	001-133	VM44	_____	_____

**Please Note:** Changes and jetting modifications are for use only on racing machines or similar off-road vehicles where pollution laws are not in effect. Not legal for vehicles operated on public highways in the State of California or other areas where similar pollution laws may apply.

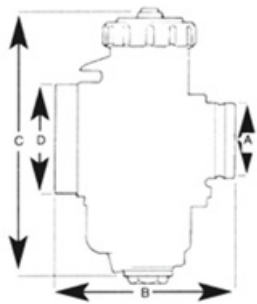

Clamp-On Mount Type



Flange Mount Type



Spigot Mount Type

## VM Series Round Slide Single Carburetor Dimensions

Size (mm)	A	B	C	D	Total Width	Throttle Adjust Position	Air Screw Position	Weight (g)	Throttle Valve Material
VM16 Clamp-On	21 ID	67	95	28	61	Left	Left	446	Aluminum
VM18-Clamp-On	22 ID	67	108	32	61	Left	Left	492	Aluminum
VM20 Flange	50.8 Bolt Center	66	115	43	76.5	Left	Left	546	Aluminum
VM22 Flange	49 Bolt Center	85	114	43	82	Left	Left	828	Aluminum
VM24 Spigot	35	80	116	43	76.5	Right	Left	670	Brass
VM26 Spigot	35	93	122	44	82	Left	Right	550	Brass
VM30 Spigot	40	93	137	58	83	Left	Right	800	Brass
VM32 Spigot Left Idle	40	102	142	58	83	Left	Right	770	Brass
VM32 Spigot Right Idle	40	102	142	58	83	Right	Right	770	Brass
VM34 Spigot Left Idle	40	93	137	58	83	Left	Right	750	Brass
VM34 Spigot Right Idle	40	93	137	58	83	Right	Right	750	Brass
VM36 Spigot	43	116	152	62	79	Left	Right	750	Brass
VM38 Spigot	43	116	154	62	79	Right	Right	830	Brass
VM44 Spigot	52	116	193	70	79	Left	Right	1104	Brass

# Mikuni VM18 Exploded View & Parts



## Mikuni VM18 Clamp-On Carburetor

Sold each. Mikuni No. VM18-144

Order No. **001-001**

### VM18 Replacement Parts

• Lined through part numbers are not available.

No.	Description	Mikuni No.	Order No.
1.	Rubber Cap, Throttle Cable	VM18/67	<b>007-685</b>
2.	Cable Adjuster	M21/14	<b>002-062</b>
3.	Nut, Cable Adjuster	B30/247	<b>002-065</b>
4.	Top, Mixing Chamber	VM16/40	<b>007-273</b>
5.	Spring, Throttle Valve	VM18/170	<b>007-274</b>
6.	Clip, Jet Needle Retaining	VM18H1/38	<b>007-686</b>
7.	E-Ring, Jet Needle	VM20/369	<b>002-083</b>
8.	Jet Needle	J8-4F18	_____
9.	Throttle Valve (slide)	VM18/158-1.0	<b>007-425</b>
10.	Rubber Cap, Starter Plunger	VM20/455	<b>002-084</b>
11.	Fitting, Starter Plunger	VM20/456	<b>002-085</b>
12.	Spring, Starter Plunger	VM16/42	<b>002-671</b>
13.	Starter Plunger	VM18/144	<b>002-092</b>
14.	Spring Plate, Starter Lever	VM18/151	_____
15.	Starter Lever	VM18/215	<b>007-687</b>
16.	Washer, Starter Lever	BV26/118	_____
17.	Nut, Clamp Bolt	N1=05	<b>007-279</b>
18.	Sealing Ring, Rubber	VM18/326	<b>007-280</b>
19.	Ring, Insulator (I.D.=23mm)	VM18/327	<b>007-281</b>
20.	Pilot Jet	VM22/210	<b>Pg.212</b>
21.	Needle Jet	VM15H1/17-0-0	_____
22.	Main Jet	4/042	<b>Pg.214</b>
23.	Gasket, Float Bowl	VM17/161	<b>007-282</b>
24.	Float Bowl	VM18/161	<b>007-283</b>
25.	Screw, Float Bowl 4x14mm	CW2=0414	<b>002-522</b>
26.	Air Adjusting Screw	VM20/305	<b>002-720</b>
27.	Spring, Air Adjusting Screw	VM15/112	<b>002-863</b>
28.	Spring, Idle Adjusting Screw	VM15/112	<b>002-863</b>
29.	Idle Adjusting Screw	VM18/164	<b>007-284</b>
30.	Bolt, Clamp	VM16/65	<b>007-285</b>
31.	Washer, Needle Valve Seat	VM15/07	<b>007-286</b>
32.	Needle Valve Assembly	VM15/172-#1.5	<b>007-288</b>
33.	Float	VM17/159	<b>007-290</b>
34.	Pin, Float	BV26/22	<b>002-107</b>
35.	Hose, Overflow	VM13/06	_____

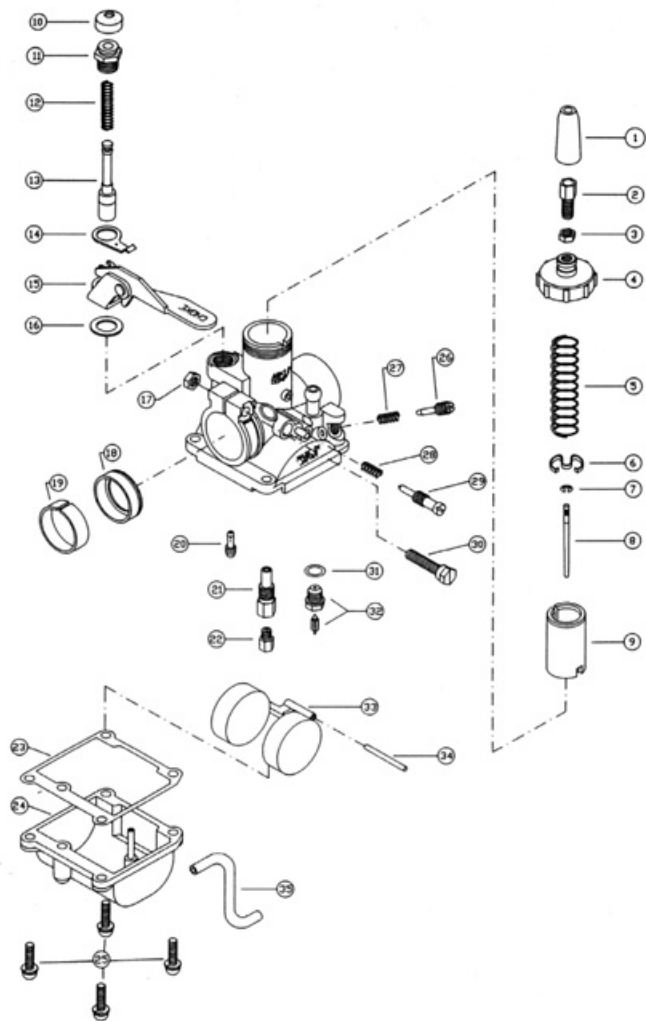

Mikuni VM Series Carburetors are intended for off-road riding and racing use only. Not legal for use in California or other locations where similar pollution laws may apply.

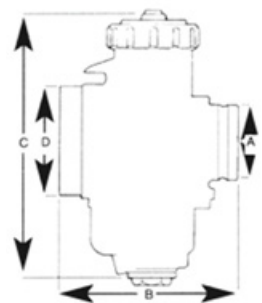

**Float Height**  
**20 - 22mm**

### Carburetor Dimensions

Size (mm)	A	B	C	D	Total Width
VM18-144	23 ID	67	108	32	61

### VM18 Clamp-On Standard Jetting Specifications

Carb Size	Main Jet	Pilot Jet	Needle Jet	Jet Needle	Throttle Valve Cutaway	Air Jet	Needle Valve Set	Float Height	Mikuni No.	Order No.
VM18	4/042 #80	VM22/210 #30	#145 O-0	#4F18	VM18/158 1.0	None	VM15/172-1.5	20-22mm	VM18-144	<b>001-001</b>



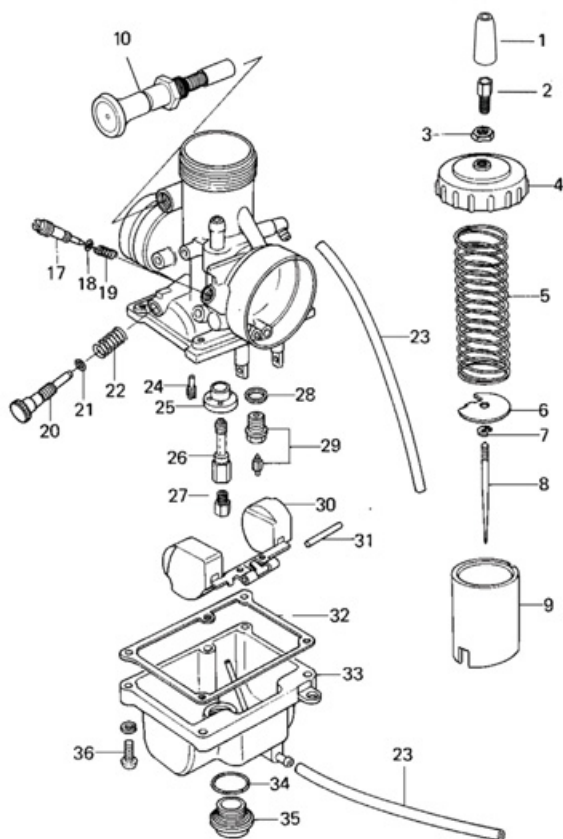

## Mikuni VM24-512 Spigot Mount Carburetor

Sold each. Mikuni No. VM24-512.

Order No. 001-018

### VM24-512 w/side choke Replacement Parts

• Lined through part numbers are not available.

No.	Description	Mikuni No.	Order No.
1.	Rubber Cap, Throttle Cable	VM26/46	002-061
2.	Cable Adjuster	M21/14	002-062
3.	Nut, Cable Adjuster	B30/247	002-065
4.	Top, Mixing Chamber	VM26/44A	002-236
5.	Spring, Throttle Valve	VM24/195	002-069
6.	Spring Seat Plate	VM26/55	---
7.	E-Ring, Jet Needle	VM20/369	002-083
8.	Jet Needle	5114	---
9.	Throttle Valve (slide)	832-27043-1.5	---
10.	Starter Plunger Assembly	VM16/210A	007-752
17.	Air Screw	VM14/73	---
18.	O-Ring, Air Screw	VM14/75	002-676
19.	Spring, Air Screw	VM15/112	002-863
20.	Idle Adjuster Screw	603-16002	---
21.	O-Ring, Idle Adjuster Screw	BV32/04	002-212
22.	Spring, Idle Adjuster Screw	VM26/197	---
23.	3mm I.D. Vent & Overflow Hose	VM17/177A	---
24.	Pilot Jet	VM22/210	Pg.212
25.	Main Jet Ring	VM26/538	---
26.	Needle Jet N-8 (864 Series)	784-111421-N-8	---
27.	Large Hex Main Hex	4/042	Pg.214
28.	Washer, Needle Valve Seat	VM26/25	002-188
29.	Needle Valve Assembly 2.5	786-15005-2.5	002-892
30.	Float	VM24/365	007-255
31.	Pin, Float	BV26/22	002-107
32.	Gasket, Float Bowl	VM20/492	007-250
33.	Float Bowl	VM22/314	---
34.	O-Ring, Drain Plug 17.5 x 1.4	BN042/64	002-602
35.	Drain Plug, Main Jet	BN042/58	---
36.	Screw, Float Bowl 4x16mm	CW2=0416	002-823

Mikuni VM Series Carburetors are intended for off-road riding and racing use only. Not legal for use in California or other locations where similar pollution laws may apply.

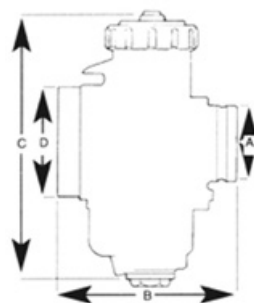

**Float Height**  
21 mm

### Carburetor Dimensions

Size (mm)	A	B	C	D	Total Width
VM24	35	80	116	43	76.5

### VM24-512 Standard Jetting Specifications

Carb Size	Main Jet	Pilot Jet	Needle Jet	Jet Needle	Throttle Valve Cutaway	Air Jet	Needle Valve Set	Float Height	Mikuni No.	Order No.
VM24	4/042	#210	VM22/210 #40	#864 N-8	#5114	832-27043 1.5	None	786-1500 2.5	21mm	VM24-512 001-018

# Mikuni VM26-606 Exploded View & Parts

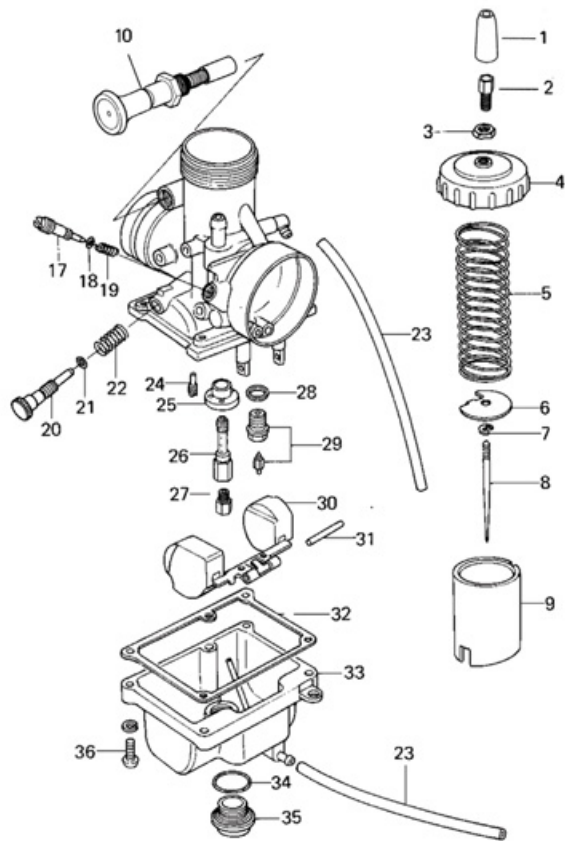

## Mikuni VM26-606 Spigot Mount Carburetor

Sold each. Mikuni No. VM26-606.

Order No. **001-021**

### VM26-606 with Side Choke Replacement Parts

• Lined through part numbers are not available.

No.	Description	Mikuni No.	Order No.
1.	Rubber Cap, Throttle Cable	VM26/46	<b>002-061</b>
2.	Cable Adjuster	M21/14	<b>002-062</b>
3.	Nut, Cable Adjuster	B30/247	<b>002-065</b>
4.	Top, Mixing Chamber	VM26/44A	<b>002-236</b>
5.	Spring, Throttle Valve	VM24/195	<b>002-069</b>
6.	Spring Seat Plate	VM28/132	<b>002-079</b>
7.	E-Ring, Jet Needle	VM20/369	<b>002-083</b>
8.	Jet Needle	J8-5E75	<b>007-005</b>
9.	Throttle Valve (slide)	VM24/361-1.5	_____
10.	Starter Plunger Assembly	VM16/210A	<b>007-752</b>
17.	Air Screw	VM14/73	_____
18.	O-Ring, Air Screw	VM14/75	<b>002-676</b>
19.	Spring, Air Screw	VM15/112	<b>002-863</b>
20.	Idler Adjuster Screw	603-16002	_____
21.	O-Ring, Idle Adjuster Screw	BV32/04	<b>002-212</b>
22.	Spring, Idle Adjuster Screw	VM26/197	_____
23.	3mm I.D. Vent & Overflow Hose	VM17/177A	_____
24.	Pilot Jet	M28/1001	<b>Pg.212</b>
25.	Main Jet Ring	VM26/538	_____
26.	Needle Jet 0-0 (332 Series)	VM26/581	<b>003-730</b>
27.	Large Hex Main Hex	4/042	<b>Pg.214</b>
28.	Washer, Needle Valve Seat	VM26/25	<b>002-188</b>
29.	Needle Valve Assembly 2.5	VM26/26-#2.5	<b>002-190</b>
30.	Float	VM24/365	<b>007-255</b>
31.	Pin, Float	BV26/22	<b>002-107</b>
32.	Gasket, Float Bowl	VM20/492	<b>007-250</b>
33.	Float Bowl	VM22/314	_____
34.	O-Ring, Drain Plug	BN042/64	<b>002-602</b>
35.	Drain Plug, Main Jet	BN042/58	_____
36.	Screw, Float Bowl 4x16mm	CW2=0416	<b>002-823</b>
see photo	VM26-606 Carb Rebuild Kit	MK-606	<b>025-660</b>

Mikuni VM Series Carburetors are intended for off-road riding and racing use only. Not legal for use in California or other locations where similar pollution laws may apply.

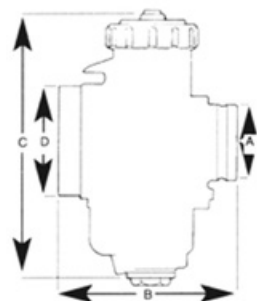

**Float Height**  
**22-24mm**

### Carburetor Dimensions

Size (mm)	A	B	C	D	Total Width
VM26	35	93	122	44	82

## VM26-606 Standard Jetting Specifications

Carb Size	Main Jet	Pilot Jet	Needle Jet	Jet Needle	Throttle Valve Cutaway	Air Jet	Needle Valve Set	Float Height	Mikuni No.	Order No.
VM26	4/042 #190	M28/1001 #22.5	#332 0-0	#5E75	VM24/361 1.5	Fixed	VM26/26-2.5	22-24mm	VM26-606	<b>001-021</b>

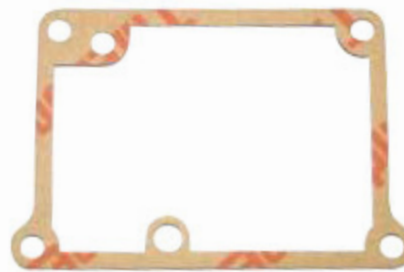
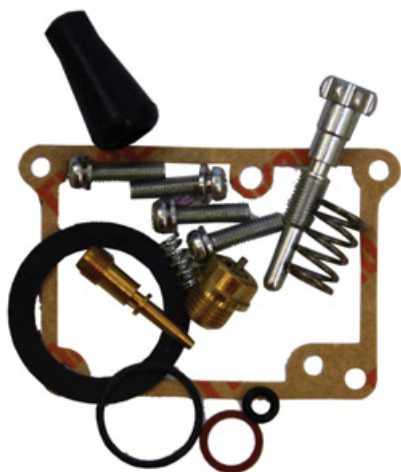

## VM26-606 Carburetor Rebuild Kit

Kit includes GENUINE Mikuni parts to rebuild the VM26 carburetor. Sold as a kit.

Order No. **025-660**

Exploded View No.	Qt	Contents
1.	1	Rubber Cap, Throttle Cable
not shown	1	Top (Cap) Cover Gasket
17	1	Air Screw
18	1	O-Ring, Air Screw
19	1	Spring, Air Screw
20	1	Idler Adjuster Screw
21	1	O-Ring, Idle Adjuster Screw
22	1	Spring, Idle Adjuster Screw
28	1	Washer, Needle Valve Seat
29	1	Needle Valve Assembly 2.5
32	1	Gasket, Float Bowl
34	1	O-Ring, Drain Plug
36	4	Screw, Float Bowl 4x16mm

## VM26 OEM Float Bowl Gasket

Genuine replacement gasket for applications listed. **Made in Japan.** Sold each.

Order No. **007-250**

### Kawasaki

Model	Year	OEM Reference
KX60A1/A2	83-84	11009-1147
KX60B1-B19	85-03	11009-1147
KX65A1-A6	00-05	11009-1147
KX65A6F/A7F/A8F/A9F	06-09	11009-1147
KX65ABF/ACF/ADF	11-13	11009-1147
KDX80A1/A2/B1/B2	80-83	11009-1147
KDX80C1/C2/C3/C4	84-88	11009-1147
KX80A1	1979	11009-1147

### KTM

65 SX	98-08	45031010100
65 XC	08-09	45031010100

### Suzuki

RM60K3/K4	03-04	K1100-91147
RM65K3/K4/K5	03-05	K1100-91147

### Yamaha

#### ATV

YFS200 Blaster	88-06	304-14184-00-00
YFZ350 Banshee	87-06	304-14184-00-00

#### Dual Sport & Offroad

YZ50G	1980	304-14184-00-00
YZ60H/J/K	81-83	304-14184-00-00
YZ80A/B/C/D/E/F/G/H/J/K/L	74-84	304-14184-00-00
YZ80N/S/T/U/W/A/B/D/E1	85-93	304-14184-00-00
YZ80F1/G1/H1/J1/K1/L/M1/N1	94-01	304-14184-00-00
DT100A/B/C/D/E/F/G/H/J/K	74-83	304-14184-00-00
MX100F/G/H/J/K	79-83	304-14184-00-00
RT100A	1990	304-14184-00-00
RT100D-M	92-00	304-14184-00-00
AT2/AT3-125 Enduro	72-73	304-14184-00-00
DT125A/B/C Enduro	74-76	304-14184-00-00
DT125E/F/G/H Enduro	78-81	304-14184-00-00
CT2/CT3-175 Enduro	72-73	304-14184-00-00
DT175A/B/C Enduro	74-76	304-14184-00-00
DT175E/F/G/H Enduro	78-81	304-14184-00-00
MX175F/G/H	79-81	304-14184-00-00
TY175B/C Trials	75-76	304-14184-00-00
RT180A-K	90-98	304-14184-00-00
TY250C/D Trials	76-77	304-14184-00-00



# MIKUNI VM Spigot Mount Type Exploded View

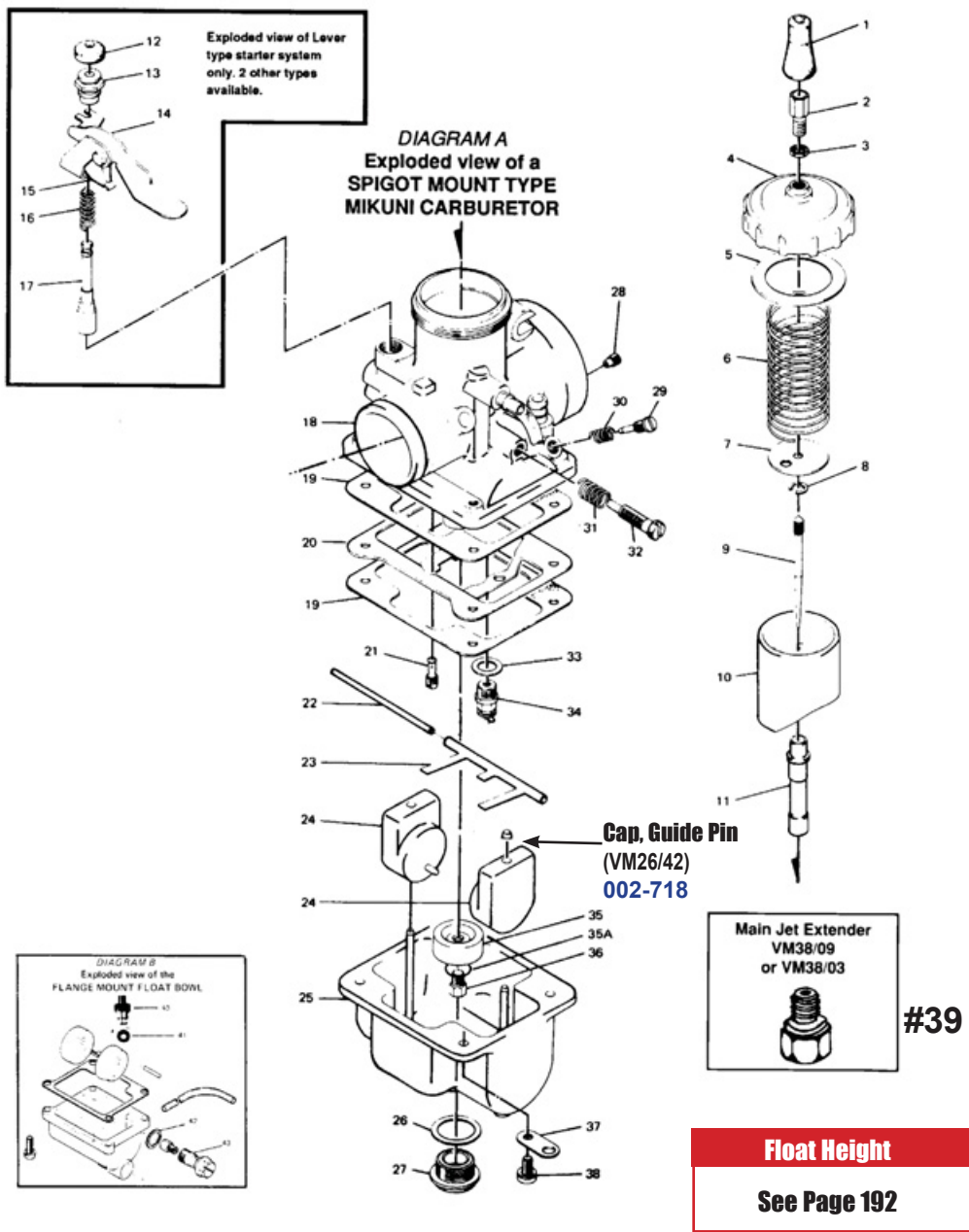

Mikuni VM Series Carburetors are intended for off-road riding and racing use only. Not legal for use in California or other locations where similar pollution laws may apply. **Note:** VM Series Standard Jetting Specifications and Float Height are listed on Page 192.

## VM Series Round Slide Single Carburetor Dimensions

Size (mm)	A	B	C	D	Total Width	Throttle Adjust Position	Air Screw Position	Weight (g)	Throttle Valve	Material
VM16 Clamp-On	21 ID	67	95	28	61	Left	Left			Aluminum
VM18-Clamp-On	22 ID	67	108	32	61	Left	Left	492		Aluminum
VM20 Flange	50.8 Bolt Center	66	115	43	76.5	Left	Left	546		Aluminum
VM22 Flange	49 Bolt Center	85	114	43	82	Left	Left			Aluminum
VM24 Spigot						Right	Left			Aluminum
VM26 Spigot	35	93	122	44	82	Left	Right	550		Brass
VM30 Spigot	40	93	137	59	83	Left	Right	800		Brass
VM32 Spigot Left Idle	40	102	142	58	83	Left	Right	770		Brass
VM32 Spigot Right Idle	40	102	142	58	83	Right				Brass
VM34 Spigot Left Idle	40	93	137	58	83	Left	Right	750		Brass
VM34 Spigot Right Idle	40	93	137	58	83	Right				Brass
VM36 Spigot	43	116	152	62	79	Left	Right	750		Brass
VM38 Spigot	43	116	154	62	79	Right	Right	830		Brass
VM44 Spigot	52	116	193	70	79	Left	Right	1104		Brass

## VM Replacement Parts

• Lined through part numbers are no longer available.

Note: VM26-606 carburetor (with side choke) parts are listed on page 196-197.

No.	Description & Application	Mikuni No.	Order No.
1.	<b>Rubber Cap, Throttle Cable</b>		
	All Mikuni VM Series Carbs	VM26/46	<b>002-061</b>
	for 45° angled cable adjuster	VM22/18	<b>002-370</b>
2.	<b>"A" Cable Adjuster</b>		
	All Mikuni VM Series Carbs (6mm)	M21/14	<b>002-062</b>
	All Mikuni VM Series Carbs (7mm)	VM28/256	<b>002-063</b>
	<b>"B" Cable Adjuster, Angled 45°</b>		
	All Mikuni VM Series Carbs	I-M22-10-3	<b>002-064</b>
3.	<b>Locknut, Cable Adjuster</b>		
	All Mikuni VM Series Carbs	B30/247	<b>002-065</b>
4.	<b>Top, Mixing Chamber</b>		
	VM26 - VM28 spigot	VM26/56	<b>002-236</b>
	VM30 small body spigot	VM26/51	<b>002-235</b>
	VM30 - VM34 spigot	VM34/27	<b>002-066</b>
	VM36 - VM38 spigot	VM36/09	<b>002-067</b>
	VM40 - VM44 spigot	VM44/05	<b>002-068</b>
	Note: Gasket comes with each VM Mixing Chamber Top.Cap		
5.	<b>Gasket, Top Mixing Chamber</b>		
	Top Gasket only VM26-VM28	VM26-57	<b>007-791</b>
	Top Gasket only VM30-VM34	VM34-29	<b>007-792</b>
	Top Gasket only VM36-VM38	VM36-06	<b>007-793</b>
	Top Gasket only VM40-VM44	VM40-07	<b>007-794</b>
6.	<b>Spring, Throttle Valve</b>		
	VM22 Flange, VM28 spigot	VM24/195	<b>002-069</b>
	VM26	VM28/58	<b>002-071</b>
	VM30 spigot (std)	VM34/50	<b>002-072</b>
	VM32 - VM34 flange (std)	VM34/50	<b>002-072</b>
	VM32 - VM36 (std)	VM34/55	<b>002-074</b>
	VM30 - VM36 spigot (Light)	VM34/06	<b>002-073</b>
	VM38 spigot (std)	VM34/152	<b>002-138</b>
	VM40 - VM44 spigot	VM44/13	<b>002-075</b>
7.	<b>Plate, Spring Seat</b>		
	VM26 - VM28, VM30 flange	VM26/54	<b>002-077</b>
	VM26 - VM28 spigot	VM28/132	<b>002-079</b>
	VM30 - VM34 spigot	VM34/31	<b>002-080</b>
	VM32 - VM34 flange	VM34/31	<b>002-080</b>
	VM36 - VM38 spigot	VM35/09	<b>002-081</b>
	VM40 - VM44 spigot	VM44/09	<b>002-082</b>
8.	<b>Clip, Needle Positioning</b>		
	VM26 - VM38 spigot	VM20/369	<b>002-083</b>
	VM40 - VM44 spigot	BS32/126	<b>002-455</b>
9.	<b>Jet Needle</b>		
	VM18, VM20, VM22	#4 Series	<b>Pg.205</b>
	VM26, VM28	#5 Series	<b>Pg.205</b>
	VM30, VM32, VM34, VM36, VM38	#6 Series	<b>Pg.205</b>
	VM40, VM44	#7 Series	<b>Pg.205</b>
10.	<b>Throttle Valve (Slide)</b>		<b>Pg.208-209</b>
11.	<b>Needle Jets</b>		
	VM18	#145 Series	———
	VM20	#239 Series	———
	VM22	#257 Series	———
	VM26 (except VM26-606)	#182 Series	<b>Pg.207</b>
	VM28	#169 Series	<b>Pg.207</b>
	VM30, VM32, VM34, VM36, VM38	#159 Series	<b>Pg.207</b>
	VM38	#166 Series	<b>Pg.207</b>
	VM40, VM44	#224 Series	<b>Pg.206</b>
12.	<b>Rubber, Starter Plunger</b>		
	VM26 - VM44 spigot	VM20/455	<b>002-084</b>
13.	<b>Fitting, Starter Plunger</b>		
	VM26	VM26/116	<b>002-815</b>
	VM30 - VM44 spigot	VM20/456	<b>002-085</b>
14.	<b>Lever, Starter</b>		
	VM26 - VM28 Spigot	VM28/135	<b>007-762</b>
	VM30 - VM34 Spigot	VM28/124	<b>002-135</b>
	VM36 - VM38 Spigot	VM32/53	<b>002-087</b>
	VM22 flange, VM40, VM44 Spigot	VM36/58	<b>002-136</b>
15.	<b>Spring Plate, Starter Lever</b>		
	VM26 & VM28 spigot	VM26/09C	<b>002-088</b>
	VM30 - VM44 spigot	VM32/17	<b>002-089</b>

## VM Replacement Parts

No.	Description & Application	Mikuni No.	Order No.
16.	<b>Starter Plunger Spring</b>		
	VM26 - VM44 spigot	VM14SC11/89	<b>002-090</b>
	VM26 - VM34 flange	VM15SC6/89	<b>002-358</b>
17.	<b>Starter Plunger</b>		
	VM24 & VM26 flange	VM15/62	<b>002-091</b>
	VM26 & VM28 spigot	VM15/62	<b>002-091</b>
	VM30 - VM34 flange	VM18/144	<b>002-092</b>
	VM30 - VM44 spigot	VM18/144	<b>002-092</b>



### Lever Type Starter System

Includes parts 12. thru 17. from exploded view.

For VM30 - VM34	<b>002-350B</b>
For VM36 - VM44	<b>002-350A</b>



### Pull-Up Type Starter System

Includes parts A. thru E. listed below.

VM20-273	VM16/210	<b>007-752</b>
VM30-VM44 spigot		<b>002-352</b>
A. Rubber Cap	VM20/455	<b>002-084</b>
B. Clip	VM14SC11/99	<b>002-096</b>
C. Starter Plunger Fitting	VM20/300	<b>002-097</b>
D. Starter Plunger Spring	VM14SC11/89	<b>002-090</b>
E. Starter Plunger	VM38/06	<b>002-098</b>



### Cable Type Starter System

Includes parts A. thru F. listed below.

For VM20, VM26-606, VM28/418 (TM28)		<b>002-353</b>
VM30-VM44 spigot	MK-412	<b>002-351</b>
A. Starter Plunger Top, Rubber Cap	VM26/46	<b>002-061</b>
B. Cable Adjuster	M21/14	<b>002-062</b>
C. Cable Adjuster Locknut	B30/247	<b>002-065</b>
D. Starter Plunger Fitting	VM15/37	<b>002-093</b>
E. Starter Plunger Spring	VM32/69	<b>002-094</b>
F. Starter Plunger VM20, VM26	VM15SC4/86	<b>007-751</b>
Starter Plunger VM30 - VM44	VM15SC4/85	<b>002-095</b>
18. <b>Mixing Chamber Body</b>	not available	———
19. <b>Float Bowl Gasket</b>		
VM20 flange	VM20/492	<b>007-250</b>
VM22 flange	———	<b>002-009</b>
VM26 - VM34 flange	VM30/103	<b>002-099</b>
VM26-28 spigot	VM28/129	<b>002-361</b>
VM30mm small body	VM30/172	<b>002-103</b>
VM30 - VM34mm spigot (without baffle plate)	VM34/30	<b>002-100</b>
VM30 - VM34mm spigot (with baffle plate)	VM34/71	<b>002-101</b>
VM36 - VM44mm spigot	VM36/20	<b>002-102</b>
20. <b>Float Bowl Baffle Plate</b>		
VM26 - VM34 spigot	VM34/72	<b>002-104</b>
VM30 - VM34 spigot (replacement)	VM34/114	<b>002-362</b>
VM36 - VM38 spigot	VM36/16	<b>002-105</b>
VM40 - VM44 spigot	VM44/12	———

## VM Replacement Parts

No.	Description & Application	Mikuni No.	Order No.
21.	<b>Pilot Jet</b>		
	VM18 - VM44	VM22/210	<b>Pg.212</b>
	VM20 Flange	M28/1001	<b>Pg.212</b>
22.	<b>Float Arm Hinge Pin</b>		
	VM26 - VM28 spigot	BV26/22	<b>002-107</b>
	VM24 - VM34 flange	BV26/22	<b>002-107</b>
	VM30 - VM44 spigot	VM30/160	<b>002-605</b>
23.	<b>Float Arm</b>		
	VM26 - VM34 flange	VM28/59	<b>002-108</b>
	VM26 - VM28 spigot	VM28/166	<b>002-109</b>
	VM30 small body	VM28/166	<b>002-109</b>
	VM30 - VM34 spigot	VM34/73	<b>002-111</b>
24.	<b>Float - Two basic types of float system: Independent (Type A) and Twin (Type B).</b>		



**A. Independent Type** - Non corrosive plastic compound.  
Standard on VM 26 - VM44 spigot and flange type

VM Carburetors			
VM26 - VM28 spigot	VM28/164		<b>002-116</b>
VM26 - VM30 flange	VM24/236		<b>002-113</b>
VM36 - VM44 flange	VM24/236		<b>002-113</b>
VM30 - VM34 spigot	VM34/36		<b>002-118</b>
with baffle plate	VM34/61		<b>002-119</b>
VM32 flange	VM32/55		<b>002-117</b>



**B. Twin Type** - Brass compound.  
Standard on VM24 - VM26 flange type carburetors

VM24 - VM26 flange	VM24/171		<b>002-114</b>
<b>B. Twin Type</b> - Non corrosive plastic compound. Standard on VM20-273 flange carburetor.			
VM20 flange	VM20/495		<b>007-725</b>



25.	<b>Float Bowl</b>		
	VM30 - VM34 spigot with overflow	VM34/68	<b>002-121</b>
	VM36 - VM38 spigot	VM36/07	<b>002-122</b>
	VM40 - VM44 spigot	VM44/04	<b>002-120</b>
26.	<b>Main Jet Plug Washer</b>		
	VM30 - VM38 spigot	4/053	<b>002-127</b>
	VM26 - VM28 spigot	VM28/134	<b>002-128</b>
	VM40 - VM44 spigot	VM28/134	<b>002-128</b>
	<b>Main Jet Plug O-Ring</b>		
VM30-36 Spigot	VM28/254		<b>002-531</b>

## VM Replacement Parts

No.	Description & Application	Mikuni No.	Order No.
27.	<b>Main Jet Plug (Drain Plug)</b>		
	VM26-8074	VM28/133	<b>002-130</b>
	VM40 - VM44 spigot	VM28/133	<b>002-130</b>
	VM30 - VM34 spigot (brass)	VM34/42	<b>002-131</b>
	VM30 - VM36 spigot	VM28/253	<b>002-526</b>
	VM30 small body spigot	VM26/160	<b>002-133</b>
	VM38 spigot	VM38/08	<b>002-134</b>
	(brass deep type plug)		
	VM30 - VM34 spigot (brass deep type plug)	VM38/08	<b>002-134</b>
	28.	<b>Air Jet</b>	
VM26 - VM44 spigot		BS30/97	<b>Pg.213</b>
29.	<b>Air Adjusting Screw</b>		
	VM26 - VM44 spigot	VM20/214	<b>002-180</b>
	VM24 - VM34 flange	VM20/214	<b>002-180</b>
30.	<b>Air Adjusting Screw Spring</b>		
	VM26 - VM44 spigot	M12F/46A	<b>002-181</b>
31.	<b>Idle Adjusting Screw Spring</b>		
	VM26 - VM44 spigot	M20/221	<b>002-182</b>
	VM24 - VM34 flange	M20/221	<b>002-182</b>
32.	<b>Idle Adjusting Screw</b>		
	VM30 spigot	VM28/142	<b>002-139</b>
	VM30 flange	VM22/171	<b>002-183</b>
	VM36 - VM38 spigot	VM22/171	<b>002-183</b>
	VM26 - VM28 spigot	VM24/224	<b>002-184</b>
	VM32 - VM34 spigot	VM24/224	<b>002-184</b>
	VM40 - VM44 spigot	VM24/224	<b>002-184</b>
	VM24 - VM34 flange	VM24/224	<b>002-184</b>
	VM30 spigot small body	VM30/170	<b>002-186</b>
	Idle Conversion for OEM Yamaha YFS200 Blaster and YFZ350 Banshee Locknut	VM24/224	<b>002-184</b>
33.	<b>Needle Valve Washer</b>		
	VM30 - VM44 spigot	BS34/52-0.5	<b>002-187</b>
	VM24 - VM30 flange	VM26/25	<b>002-188</b>
	VM26 - VM28 spigot	VM26/25	<b>002-188</b>
34.	<b>Needle Valve Set (Needle Valve &amp; Seat Assembly)</b>		
	<b>All Needle Valve seats for VM series are thread-in type. See page 201 for photo and carburetor applications.</b>		
35.	<b>Main Jet Ring</b>		
	VM26-VM28, VM40 - VM44 spigot	VM28/228	<b>002-201</b>
	VM30 - VM38 spigot	VM36/17	<b>002-202</b>
35A.	<b>Main Jet Washer</b>		
	All VM with no main jet ring	VM20/169	<b>002-203</b>
	VM28 spigot	VM15/80A	<b>002-239</b>
36.	<b>Main Jet</b>		
	All VM	4/042	<b>Pg.214</b>
37.	<b>Anchor Plate</b>		
	VM26 - VM28 spigot	VM15/164	—
	VM30 - VM44 spigot	VM28/79A	<b>002-204</b>
38.	<b>Float Bowl Screw</b>		
	VM26 - VM28 spigot (4x16mm)	CW2=0416	<b>002-823</b>
	VM30 - VM44 spigot (5x18mm)	CW2=0518	<b>002-719</b>
39.	<b>Main Jet Extender</b>		
	VM38 spigot with Needle Jet #159 Series and #166 Series	VM38/09	<b>002-207</b>
40.	<b>Needle Jet Setter</b>		
	VM26 - VM34 flange	VM28/53	<b>002-209</b>
41.	<b>Needle Jet Setter O-Ring</b>		
	VM22 - VM34 flange	BV32/04	<b>002-212</b>
42.	<b>Banjo Bolt Washer</b>		
	VM22 flange	VM26/125	<b>002-213</b>
	VM24 - VM34 flange	VM26/124	<b>002-214</b>
	VM30 flange	30BIC/35	<b>002-215</b>
43.	<b>Banjo Bolt</b>		
	VM22 - VM24 flange	VM24/286	<b>002-216</b>
	VM26 - VM34 flange	VM28/61A	<b>002-217</b>

**Mikuni Rubber Mounting Flanges, See Page 219**



VM15/172



VM26/26



VM28/163



VM38/11



VM28/511 & VM34/39

## Needle Valve Assembly (No. 34. in exploded view)

Applications: VM16, VM18 Clamp-On & VM20mm Flange

Size	Application	Mikuni No.	Order No.
(1.5)		VM15/172	007-288
(2.0)		VM15/172	007-289
	Washer for Needle Valve Seat	VM15/07	007-286

Applications: VM22mm - VM30mm Flange, VM26 - VM28mm Spigot, VM30 Spigot with Small Body

Size	Application	Mikuni No.	Order No.
(1.0)		VM26/26	002-230
(1.2)		VM26/26	002-234
(1.5)		VM26/26	002-231
(2.0)		VM26/26	002-189
(2.5)		VM26/26	002-190
(2.8)		VM26/26	002-191
	Washer for Needle Valve Seat	VM26/25	002-188



Applications: VM32 - VM34mm Flange, VM32 - VM34mm Spigot

Size	Application	Mikuni No.	Order No.
(3.0)		VM34/39	002-192
(3.3)		VM34/39	002-193
(1.2)		VM28/163	002-195
(1.5)		VM28/163	002-196
(1.8)		VM28/163	002-197
(2.0)		VM28/163	002-198
(2.5)		VM28/163	002-199
	Washer for Needle Valve Seat	B34/52	002-187
(3.5)		VM38/11	002-200
(3.5)	OEM Yamaha 24X-14107-35-00	VM38/11	002-200

Applications: VM30 - VM38mm Spigot VM30 - VM44mm Spigot - Snowmobile OEM (with viton tip needle)

Size	Application	Mikuni No.	Order No.
(1.5)		VM28/511	002-233
(1.8)		VM28/511	002-895
(2.0)		VM28/511	002-896

## Priming Nozzle

For oil injection. Sold each.

VM34/181 Order No. 007-690



## 40° Cable Adjuster Assembly

Includes rubber cap, two locknuts, cable adjuster and 40° tube. Works on Keihin and Mikuni carburetor caps.

Order No. 007-730



## TM Power Jet Kit

The Power Jet Kit is used on 2-stroke engine applications to improve mid-range throttle response and add additional fuel to wide open throttle running conditions. Easily installs on TM series Carburetors. (#80, #100 and #120 sized jets included) Sold as a kit.

Order No. 002-041



## 90° Cable Adjuster Assembly

This adjuster has threads on one end, the other end swivels. Includes rubber cap, locknut, cable adjuster and 90° tube. Works on Keihin and Mikuni carburetor caps.

Order No. 007-731



## 45° Cable Adjuster

45° Cable Adjuster fits all Mikuni VM Carburetor Series #2 in Mikuni VM parts list Works on all Mikuni VM Carburetor Series Carbs. Adjuster, locknut, and rubber cap all sold separate.

Description	Mikuni No.	Order No.
Angles 45° Cable Adjuster	I-M22-10-3	002-064
Cable Adjuster Locknut	B30/247	002-065
Throttle Cable Rubber Cap	VM22/18	002-370

## Quick Reference Chart for Needle Selection (Average Performance Chart)

**Note:** The following listing of needles are simply the average performance of a needle between 1/4 and 3/4 throttle opening. Needles are constructed such that a given point on a needle, (for example, at 3/4 throttle opening), the needle may be found to perform richer at this given point when compared to the same given point on another needle, but according to the average performance chart, the needle should perform leaner.

**For example:**  
Average Performance Chart  
Leaner



Richer

At D-5 (A), the taper diameter is 1.915, at D-5 (B), the taper is 2.040; the taper diameter at D-5 (A) is smaller than D-5 (B). At this given point of throttle opening (3/4), needle #6DH4 will run slightly richer than #6FJ6, but the average performance will still be that #6DH4 will be a leaner needle because it will perform leaner at more given points than a #6FJ6. Consequently, if you are concentrating on a specific throttle opening for competition use, be certain to check the taper diameter at that point of throttle opening.

For a more detailed and comprehensive explanation of the various needles as to their taper diameters at given points, see **NEEDLE TAPER DIAMETER DIMENSION CHARTS**.

### THE QUICK REFERENCE CHART FOR NEEDLE SELECTION

was prepared by measuring the needles as to their diameter at given points. Given points are 10mm apart from each other.

By computing the different measurements and arranging them in order of taper thickness or thinness, three categories for application of needles were determined.

#### Category I - Competition.

For example, motocross racing and desert racing where mid-range throttle operation is vital.

#### Category II - Racing.

For example, Road racing, where 3/4 to full throttle operation is vital.

#### Category III - Overall.

For example, Street riding, where the full range of throttle operation is required.

## Jet Needle #4 Series

		Competition	Racing	Overall
Leaner	1	#4D8	#4P3	#4P3
	2	#4DH7	#4D8	#4D8
	3	#4DG6	#4D3	#4D3
	4	#4P3	#4F10	#4DG6
	5	#4D3	#4DG6	#4DH7
	6	#4F6	#4F6	#4F10
	7	#4F10	#4DH7	#4F6
	8	#4F15	#4F15	#4F15
	9	#4E14	#4E1	#4E1
	10	#4J13	#4L13	#4L13
	11	#4L6	#4J11	#4J13
	12	#4L13	#4J13	#4J11
Richer	13	#4L11	#4L6	#4L6

## Jet Needle #5 Series (A)

		Competition	Racing	Overall
Leaner	1	#5D6	#5C4	#5C4
	2	#5D120	#5D6	#5D6
	3	#5C4	#5D5	#5D5
	4	#5EJ13	#5D120	#5D120
	5	#5J9	#5D1	#5F18
	6	#5F18	#5F18	#5D1
	7	#5DP7	#5F16	#5EJ13
	8	#5FL14	#5FJ9	#5F3
	9	#5F3	#5F3	#5EH7
	10	#5EH7	#5EJ13	#5FJ9
	11	#5FL	#5EH7	#5DP
	12	#5D5	#5DH21	#5FL14
	13	#5E13	#5FL14	#5FL7
	14	#5L1	#5FL7	#5E13
	15	#5J6	#5E13	#5F16
	16	#5D1	#5DP7	#5DH21
	17	#5F9	#5J9	#5J9
	18	#5F16	#5J6	#5J6
	19	#5DH21	#5L1	#5L1
Richer	20	#5F12	#5F12	#5F12

## Jet Needle #5 Series (B)

		Competition	Racing	Overall
Leaner	1	#5EP8	#5DP2	#5DP2
	2	#5EJ11	#5DL13	#5DL13
	3	#5EL9	#5EJ11	#5EJ11
	4	#5EL9	#5EJ11	#5EJ11
	5	#514	#5EP8	#5EP8
	6	#5DL13	#5FL11	#5FL11
Richer	7	#5DP2	#514	#514





## Two Types of needles

### Single Taper Type

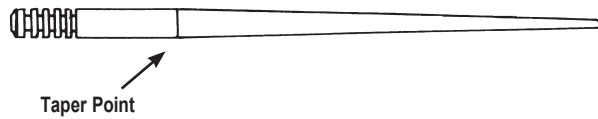

### Double Taper Type

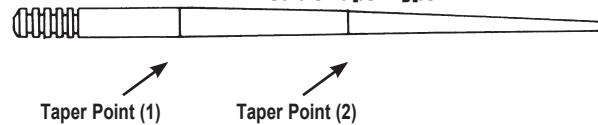

## Jet Needles

The Jet Needle controls the fuel mixture in the mid-range (1/4-3/4) throttle position. The taper of the needle determines the amount of fuel. For example, the thinner the diameter of the needle, the more fuel will be drawn. The thicker the diameter of the needle, the less fuel will be drawn.

## Needle Taper Diameter Dimension Chart

D-1 through D-5 indicates diameter (mm) at each point.

	A	B	D-1	D-2	D-3	D-4	D-5
#4E1	50.3	28.0	2.515	2.515	2.345	2.127	1.924
#4DH7	50.3	23.0	2.518	2.518	2.386	2.098	1.790
#4J13	50.2	24.0	2.513	2.513	2.230	1.800	1.40
#4L6	50.3	24.5	2.515	2.515	2.178	1.660	1.190
#4J11	41.5	21.3	2.512	2.506	2.188	1.776	

D-1 through D-6 indicates diameter (mm) at each point.

	A	B	D-1	D-2	D-3	D-4	D-5	D-6
#5F3	58.0	27.4	2.519	2.519	2.419	2.135	1.863	
#5EJ11	60.3	28.5	2.515	2.515	2.515	2.241	1.839	1.420
#5FL11	60.3	28.2	2.518	2.518	2.438	2.175	1.740	1.256
#5FL14	58.0	28.0	2.520	1.520	2.440	2.170	1.735	
#5FL7	58.0	28.0	2.518	2.518	2.440	2.170	1.735	1.735
#5DP7	57.6	26.4	2.512	2.512	2.440	2.259	1.580	
#5J6	58.0	27.5	2.518	2.518	2.340	1.890	1.450	
#5L1	58.0	27.0	2.518	2.518	2.330	1.811	1.297	
#5J9	58.0	27.0	2.522	2.520	1.432	1.996	1.505	

D-1 through D-6 indicates diameter (mm) at each point.

	A	B	C	D-1	D-2	D-3	D-4	D-5	D-6
#6F5	62.3	38.1	19.0	2.515	2.456	2.454	2.364	2.098	1.840
#6F4	62.3	32.0	19.4	2.515	2.442	2.436	2.206	1.939	1.678
#6F8	62.3	34.0	21.5	2.512	2.512	2.386	2.214	1.945	1.688
#6F16	64.6	31.2	18.4	2.520	2.404	2.400	2.201	1.941	1.679

## Needle Taper Diameter Dimension Chart

(a)=Needle Length (mm)

(b)=Length between points (x) and the taper point (Y)

1=10mm

2=20mm

3=30mm

4=40mm

5=50mm

D-1, -2, -3, -4, -6 are the actual taper diameters at those given points in millimeters

## #Series Type

## Application

#4	All VM18 Carburetors, VM20 VM22, VM24
#5	VM26 - VM32 Spigot VM28 - VM34 Flange TM24, TM32, TM34
#6	VM30 - VM38 Spigot
#7	VM40 - VM44 Spigot
#8	HSR42, HSR45, HSR48
#9	RS34 - RS40 Smoothbore, TM36, TM40 (HS40) Pumper Carb

D-1 through D-6 indicates diameter (mm) at each point.

	A	B	D-1	D-2	D-3	D-4	D-5	D-6
#6DH2	62.3	28.0	2.511	2.511	2.466	2.295	2.000	1.660
#6F9	62.3	28.9	2.516	2.516	2.475	2.210	1.949	1.678
#6CF1	61.5	29.5	2.512	2.512	2.429	2.240	1.974	1.710
#6FJ6	62.3	35.2	2.505	2.505	2.505	2.376	2.040	1.606
#6DH3	62.3	22.0	2.512	2.512	2.458	2.286	1.948	1.607
#6L1	62.3	37.0	2.512	2.512	2.512	2.335	1.826	1.313
#6DP17	62.3	32.1	2.518	2.518	2.518	2.372	1.834	1.141
#6N1	62.3	37.0	2.514	2.514	2.514	2.278	1.672	1.058
#6DP1	62.3	28.9	2.511	2.511	2.476	2.312	1.748	1.075
#6DH4	62.3	25.5	2.520	2.520	2.440	2.258	1.915	1.575
#6DH7	62.2	28.5	2.516	2.516	2.505	2.316	2.009	1.688
#6DH8	62.2	20.3	2.538	2.538	2.436	2.208	1.827	1.497
#6FL14	62.1	26.7	2.538	2.538	2.538	2.233	1.649	1.218
#6F15	62.2	19.8	2.535	2.538	2.461	2.208	1.979	1.649
#6DP10	62.4	26.5	2.51	2.51	2.44	2.26	1.56	0.89
#6F13	64.2	32.8	2.50	2.46	2.46	2.24	1.97	1.70
#6DL30	64.7	26.3	2.51	2.51	2.45	2.09	1.66	1.24

D-1 through D-7 indicates diameter (mm) at each point.

	A	B	D-1	D-2	D-3	D-4	D-5	D-6	D-7
#7DH5	72.2	27.4	2.98	2.98	2.94	2.78	2.4	2.08	1.72
#7F7	72.3	33.1	2.99	2.99	2.99	2.80	2.54	2.28	2.02
#7F6	72.3	29.0	3.00	3.00	2.95	2.68	2.41	2.14	1.87
#7DH3	72.5	28.1	2.98	2.98	2.96	2.80	2.47	2.11	1.76
#7DH2	75.3	31.6	2.99	2.99	2.99	2.84	2.66	2.27	1.92

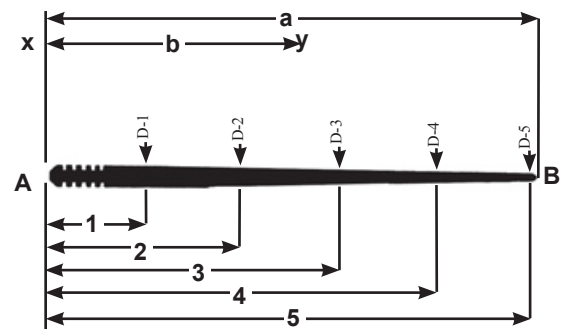
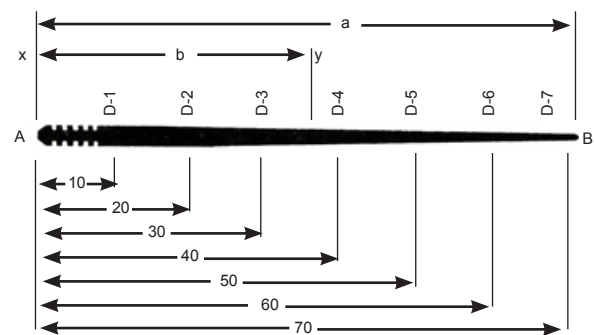

## Jet Needles for Flat Slide Carburetors .

Sold each

### Applications: TM36, TM38, 39 Pro-Series, 41 Pro-Series

Jet Needle No.	Needle Diameter before Taper (mm)	Air/Fuel Ratio	Order No.
#6FJ41	2.522	Leaner	002-713
#6FM46	2.522	↕	002-349
#6FJ40	2.522	↕	002-712
#6DP4	2.515	Richer	002-341

### Applications: Early Style Flat Slide TMX38

#6EJ12-60	2.60	Leaner	007-077
#6EJ12-59	2.59	↕	007-076
#6EJ12-58	2.58	↕	007-075
#6EJ12-57	2.57	↕	007-074
#6EJ12-56	2.56	↕	007-073
#6EJ12-55	2.55	↕	007-072
#6EJ12-54	2.54	↕	007-071
#6EJ12-53	2.53	Richer	007-070

### Applications: Early Style Flat Slide TMX35

#6EN11-58	2.58	Leaner	007-056
#6EN11-57	2.57	↕	007-055
#6EN11-56	2.56	↕	007-054
#6EN11-55	2.55	↕	007-053
#6EN11-54	2.54	↕	007-052
#6EN11-53	2.53	↕	007-051
#6EN11-52	2.52	Richer	007-050

### Applications: TMS38-77, 78 (125cc)

#6GDY12-59	2.59	Leaner	007-088
#6GDY12-58	2.58	↕	007-087
#6GDY12-57	2.57	↕	007-086
#6GDY12-56	2.56	Richer	007-085

### Applications: TMS38-77, 78 (250cc)

#6DGY04-60	2.60	Leaner	007-048
#6DGY04-59	2.59	↕	007-047
#6DGY04-58	2.58	↕	007-046
#6DGY04-57	2.57	↕	007-045
#6DGY04-56	2.56	↕	007-044
#6DGY04-55	2.55	↕	007-043
#6DGY04-54	2.54	Richer	007-042

### Applications: RS34, RS36 Smoothbore

#9DZH01 (Std)	2.50	Leaner	007-035
#9DZH03	2.49	↕	007-037
#9DZH04	2.48	Richer	007-038

### Applications: RS38, RS40 Smoothbore

#9CHY03 (Std)	2.99	Leaner	007-020
#9CHY05	2.98	↕	007-022
#9CHY06	2.97	Richer	007-023

## Jet Needles for Flat Slide Carburetors .

Sold each

### Applications: HSR42

Jet Needle No.	Needle Diameter before Taper (mm)	Air/Fuel Ratio	Order No.
#8DDY01-98	2.98	Leaner	007-083
#8DDY01-97 (Std)	2.97	↕	007-082
#8DDY01-96	2.96	↕	007-081
#8DDY01-95	2.95	Richer	007-080

### Applications: HSR45

#8CFY02-98	2.98	Leaner	007-103
#8CFY02-97 (Std)	2.97	↕	007-102
#8CFY02-96	2.96	↕	007-101
#8CFY02-95	2.95	Richer	007-100

### Applications: HSR48

#8CFY15-98	2.98	Leaner	007-098
#8CFY15-97 (Std)	2.97	↕	007-097
#8CFY15-96	2.96	↕	007-096
#8CFY15-95	2.95	Richer	007-095

### Applications: TM36-68 Pumper Carb

#9DZH06-50 (Std)	2.50	Leaner	007-109
#9EBY01-51	2.51	↕	007-106
#9EBY01-50	2.50	Richer	007-105

When using these Jet Needles **007-105** & **007-106**, the use of a larger pilot jet may be required.

### Applications: HS40 (TM40-6) Pumper Carb

#9DJY01	2.97	Leaner	007-015
#9DJY04 (Std)	2.96	↕	007-018
#9DJY03	2.96	↕	007-017
#9DJY02	2.95	Richer	007-016

### Jet Needle E-Ring (Clip)

Application	Mikuni No.	Order No.
RS34-RS36	VM20/369	002-083
RS38-RS40	BS32/126	002-455
HS40, TM36, TM40	BS32/126	002-455
All HSR42/45/48	BS32/126	002-455
TMS38	BS32/126	002-455
TMX35, TMX38	BS32/126	002-455



Photo courtesy of Bonneville Performance  
#35 Kyle Ragsdale

## Jet Needles for VM, TM, and RS Carburetors

Sold each.

### #4 Series: VM18, VM20, VM22, VM24 Flange

Mikuni No.	Order No.	Application, Std.
#4D10	002-243	
#4D20	002-244	VM22-133 (Std.)
#4DH7	002-245	Suzuki GT380 74-77
#4DH11	002-246	
#4DH22	002-247	
#4F15	002-254	
#4J11	002-256	
#4J13	002-257	VM20-273 (Std.)
#4L6	002-258	

### #5 Series: VM26 - VM32 Spigot

#### VM28 - VM34 Flange, TM24, TM32, TM34

Mikuni No.	Order No.	Application, Std.
#5DI20	002-267	
#5DL31	002-268	
#5DP7	002-271	
#5DP10	002-272	
#5DP39	002-273	VM28-418 (TM28) (Std.)
#5E75	007-005	VM26-606 Side Choke (Std.)
#5EL9	002-279	
#5EP6	002-280	
#5F3	002-281	
#5F12	002-283	
#5F21	002-287	VM26-8074 (Std.)
#5FL14	002-291	
#5FP17	007-001	TM32-1 (Std.) TM34-2 (Std.)
#5J11	007-003	
#5L1	002-297	Yamaha RD400 76-78
#5N13	007-002	TM24-8001 (Std.)

### #5 Series: TM33-8012 Pumper Carb

#5FP96	007-004	TM33-8012 (Std.)
#5FP96	007-004	DR350 (90-99) w/TM33



## Sudco Carburetor Needle Shims

Sold 12 piece package.

Description	Dimensions - Inside, Outside, Thickness	Order No.
Most Keihin	.126" I.D. x .275" O.D. x .020" (0.5mm) thick	009-396
Most Mikuni	.106" I.D. x .250" O.D. x .020" (0.5mm) thick	009-395

## Jet Needles for VM, TM, and RS Carburetors

Sold each.

### #6 Series: VM30 -VM38 Spigot

Mikuni No.	Order No.	Application, Std.
#6DH2	002-299	
#6DH3	002-300	
#6DH4	002-301	VM34-168, VM34-275, (Std.)
#6DH7	002-302	
#6DH8	002-303	
#6DJ30	002-340	
#6DP1	002-304	VM38-9 (Std.)
#6DP4*	002-341	
#6DP17	002-309	VM32-193, VM32-33 (Std.)
#6F4	002-312	
#6F5	002-313	VM30-83 (Std.)
#6F8	002-314	
#6F9	002-315	
#6F13	002-316	
#6F15	002-317	
#6F16	002-318	
#6F21	002-319	
#6FJ6	002-321	VM36-4 (Std.)
#6FJ40*	002-712	TM36-2 (Std.)
#6FJ41*	002-713	TM38-85, TM38-86 (Std.)
#6FJ41*	002-713	TM39/TM41 Pro (Std.)
#6FL14	002-324	
#6FL25	002-344	
#6J1	002-325	
#6L1	002-327	
#6FM46*	002-349	
#6N1	002-328	

\* For TM36, TM38, TM39/TM41 Pro-Series.

### #7 Series: VM40 - VM44 Spigot

Mikuni No.	Order No.	Application, Std.
#7DH2	002-332	
#7DH3	002-336	
#7DH5	002-345	
#7E1	002-334	
#7F6	002-329	
#7F7	002-333	VM44-3 (Std.)

### #9 Series: RS34, RS36 Smoothbore

Mikuni No.	Order No.	Application, Std.
#9DZH01	007-035	
#9DZH03	007-037	
#9DZH04	007-038	

### #9 Series - RS38, RS40 Smoothbore

Mikuni No.	Order No.	Application, Std.
#9CHY03	007-020	
#9CHY05	007-022	
#9CHY06	007-023	

### Jet Needle E-Ring (Clip)

Application	Mikuni No.	Order No.
HS40, TM36, TM40	BS32/126	002-455
HSR42/45/48	BS32/126	002-455
RS34-RS36	VM20/369	002-083
RS38-RS40	BS32/126	002-455
TM24 - TM38	VM20/369	002-083
TM33 Pumper	VM20/369	002-083
VM18 clamp-on	VM20/369	002-083
VM26 - VM38	VM20/369	002-083
VM29 Smoothbore	VM20/369	002-083
VM33 Smoothbore	VM20/369	002-083
VM40 - VM44 spigot	BS32/126	002-455

## Primary Type



"P"  
Primary Choke Type

## Bleed Type



"B"  
Bleed Type

Two Basic Types of Needle Jets

## Needle Jets

The needle jet is the main fuel passage to the main bore (venturi) of the Mikuni carburetor. Depending on the inside diameter of a specific needle jet, this will also effect the function of the needle. Therefore, needle jets and jet needles act together as the main system in controlling the amount and mixture of the fuel which is drawn in mid-range (1/4 - 3/4) throttle operation.

On the following application chart, it is noted that certain needle jets require a specific type of main jet because there are two types of main jets (4/042 Large Hex & N100.604 Large Round) that have different fuel flow rate characteristics. Also, needle jets are available not only in types, but series and sizes. Mikuni series numbers for style of the needle jet. There sizes (inside diameter size) within each series are listed according to a letter-number combination.

The letter shows the inside diameter size in increments of .050mm.

For example, the difference between P-2 and Q-2 is that the inside diameter of needle jet size Q-2 is .050mm greater than P-2.

The number shows the inside diameter size in increments of .005mm. For example, the difference between P-2 and P-4 is that the inside diameter of needle jet size P-4 is .01mm greater than P-2.

**Exception:** (-5) is measured as an increment increase of .005mm. For example, the difference between P-4 and P-5 is that the inside diameter of needle jet size P-5 is .005mm greater than P-4.

## Needle Jet Orifice Diameters

Size	-0	-1	-2	-3	-4	-5	-6	-7	-8	-9
N	2.550	2.555	2.560	2.565	2.570	2.575	2.580	2.585	2.590	2.595
O	2.600	2.605	2.610	2.616	2.620	2.625	2.630	2.635	2.640	2.645
P	2.650	2.655	2.660	2.665	2.670	2.675	2.680	2.686	2.690	2.695
Q	2.700	2.705	2.710	2.715	2.720	2.725	2.730	2.735	2.740	2.745

## Needle Jets

Lean to Rich

Chart Size	Lean	Rich
N-0		
N-2		
N-4		
N-6		
N-8		
O-0		
O-2		
O-4		
O-5		
O-6		
O-8		
P-0		
P-2		
P-4		
P-5		
P-6		
P-8		
Q-0		
Q-2		
Q-4		
Q-5		
Q-6		
Q-8		
R-0		
R-2		
R-4		
R-6		

## 224 Series Needle Jet

**Note:** Letters Z, AA, BB and CC are sizes in increments of .050mm. Numbers 0 and 5 are sizes in increments of .025mm.

Size	#224 (VM44/10) Series	Lean	Rich
Z-0	003-495		
Z-5	003-496		
AA-0	003-497		
AA-5	003-498		
BB-0	003-499		
BB-5	003-500		
CC-0	003-501		
CC-5	003-502		

## 723 Series Needle Jet

Size	723 Series	Lean	Rich
Y-2	003-685		
Y-4	003-686		
Y-6	003-687		
Y-8	003-688		
Z-0	003-689		

## Needle Jet Series

Series	Size	Type	Carb Application
159	N-4 thru R-8	P	VM30 - VM36mm Spigot
166(=480)	O-0 thru R-8	P	VM38mm Spigot
169(=172)	O-0 thru R-8	P	VM28 - VM30mm small body
171	N-0 thru Q-8	P	VM30mm Flange
175	N-0 thru Q-8	B	VM28mm Spigot, TM28 Flat
176(=270)	N-0 thru Q-8	B	VM30 - VM36mm Spigot
182	N-0 thru Q-8	P	VM26mm Spigot
183	N-0 thru Q-8	B	
188	O-2 thru P-8	P	VM32 Flange, Kawasaki
192	N-0 thru Q-8	P	VM26 Flange
193	N-0 thru Q-8	P	VM24 Flange
196	O-0 thru Q-5	P	
205	O-0 thru Q8	P	VM34mm Flange
211	N-0 thru Q-8	P	Kawasaki KR250/350/750
224	Z-0 thru CC-5	P	VM40 - VM44mm Spigot
247	P & Q only	P	Yamaha early YZ250, YZ400, IT400
247	P-0 thru R-8	P	
258	O & P only	B	Kawasaki KZ650/1000 w/VM carbs, Suzuki DR, SP, GS550,GS750/850 Yamaha SR500, TT500, XT500
258	O-0 thru P-8	B	
261	O-2 thru P-8	B	VM29 & VM33 Smoothbore
332	O-0 only	B	VM26-606 with side choke, Flange TM32, 34, 36, 38, 41 Pro & Flat
389	Q-0 thru R-8	P	Slide
454	P-8 thru Q-0	B	TM24 Flat Slide
499	P-2 thru Q-4	B	TM33 Flat Slide
568	O-6 thru P-8	P	RS34, RS36, TM36
568	Y-O thru Z-6	P	RS38 - RS40, HS40, TM40
633	S-4 thru S-9	P	OEM TMX (Late Style)
<b>Note: 633 Series not shown in chart, see page 191.</b>			
640	P-4 thru Q-2	B	TM33-8012 Flat Slide, Pumper
723	Y-2 thru Z-0	P	HSR42-48 Roller Flat Slide

Size	159 Series	166(=480) Series	169(=172) Series	171 Series	175 Series	176(=270) Series	182 Series	183 Series	188 Series	192 Series	193 Series	
N-0			003-249	003-271		003-324	003-352	003-372				Lean
N-2			003-250	003-272		003-325	003-353	003-373				
N-4	003-200		003-251	003-273				003-374				
N-6			003-252	003-274			003-355	003-375				
N-8	003-202		003-253	003-275			003-356	003-376			003-428	
O-0	003-203	003-227	003-254	003-276		003-329	003-357	003-377				
O-2	003-204	003-228	003-255	003-277		003-330	003-358	003-378	003-394	003-413		
O-4	003-205	003-229	003-256	003-278	003-306	003-331	003-359	003-379	003-395			
O-5	003-543	003-545	003-257									
O-6	003-206	003-230	003-258		003-307	003-333		003-381			003-432	
O-8	003-207	003-231	003-259	003-280	003-308	003-334	003-361	003-382	003-398		003-433	
P-0	003-208	003-232	003-260	003-281	003-309		003-362	003-383	003-399	003-419	003-434	
P-2	003-209	003-233	003-261	003-282	003-310	003-336	003-363	003-384		003-420	003-435	
P-4	003-210	003-234	003-262	003-283	003-311	003-337		003-385		003-421	003-436	
P-5	003-211	003-235	003-263		003-312							
P-6	003-212	003-236	003-264	003-284	003-313	003-339	003-365	003-386		003-422	003-437	
P-8	003-213	003-237	003-265	003-285	003-314	003-340	003-366	003-387	003-404	003-423	003-438	
Q-0	003-214	003-238	003-266	003-286	003-315		003-367	003-388				
Q-2	003-215	003-239	003-267	003-287			003-368	003-389				
Q-4	003-216	003-240	003-268	003-288			003-369	003-390				
Q-5	003-217	003-546	003-547									
Q-6	003-218	003-241	003-269	003-289			003-370	003-391				
Q-8	003-219	003-242	003-270	003-290			003-371	003-392				
R-0	003-220	003-243		003-291								
R-2	003-221	003-244										
R-4	003-223	003-245										
R-5	003-224	003-246										
R-6	003-225	003-247										
R-8	003-226	003-248										Rich

Size	196 Series	205 Series	211 Series	247 Series	258 Series	261 Series	332 Series	389 Series	454 Series	499 Series	568 Series	640 Series	
N-0			003-474										Lean
N-2			003-475										
N-4			003-476										
N-6			003-477				003-735						
N-8			003-478										
O-0	003-439	003-457	003-479		003-522			003-570					
O-2	003-440	003-458	003-480		003-523			003-571					
O-4	003-441	003-459	003-481		003-524	003-534		003-572					
O-5	003-442	003-460											
O-6	003-443	003-461	003-482		003-525	003-535		003-573			003-650		
O-8		003-462	003-483		003-526	003-536		003-574			003-651		
P-0		003-463	003-484	003-510	003-527	003-537		003-575			003-652		
P-2			003-485	003-511	003-528	003-538		003-576		003-606	003-653		
P-4		003-465	003-486	003-512	003-529	003-539		003-577			003-654	003-698	
P-5	003-448			003-513									
P-6		003-466	003-487	003-514	003-530			003-578			003-655	003-699	
P-8	003-450	003-467	003-488	003-515	003-531	003-549		003-579	003-679	003-609	003-656	003-700	
Q-0	003-451	003-468	003-489	003-516				003-580	003-680	003-610		003-701	
Q-2	003-452	003-469	003-490	003-517				003-581		003-611		003-702	
Q-4		003-470	003-491	003-518				003-582		003-612			
Q-5	003-454	003-471		003-519									
Q-6		003-472	003-492	003-520				003-583					
Q-8		003-473	003-493	003-521				003-584					
R-0				003-553				003-585					
R-2				003-554				003-586					
R-4				003-555				003-587					
R-5													
R-6				003-556				003-588					
R-8				003-557				003-589					
Y-0											003-663		
Y-2											003-664		
Y-4											003-665		
Y-6											003-666		
Y-8											003-667		
Z-0											003-668		
Z-2											003-669		
Z-4											003-670		
Z-6											003-671		Rich

# Mikuni VM Roundslide Throttle Valves

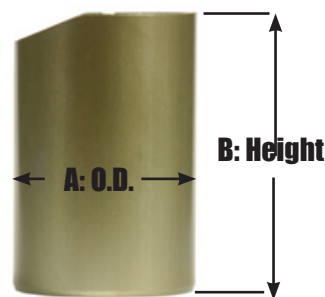
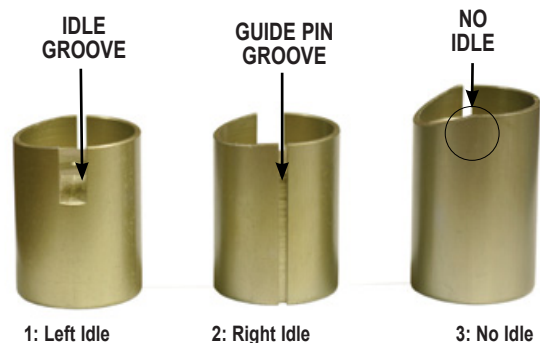

## Throttle Valve (Slides)

The Throttle Valve (slide) affects the air-fuel mixture ratio between 1/8 and 1/2 throttle, and especially between 1/8 and 1/4 throttle. Throttle Valves come in various sizes called cutaway. The larger the cutaway (size), the leaner the fuel mixture. The smaller the cutaway (size), the richer the mixture. Throttle Valves are sold each.

Application	Cutaway	Composition (material)	Idle Groove Position	Guide Pin Position	Guide Pin Groove Type	Dimension	G. Grv. Width	Mikuni No.	Order No.
VM26 & VM28 Spigot	1.0	Brass	Left	Right	Narrow	A=30mm, B=33.5mm	2.05	VM28/56	<a href="#">003-009</a>
VM26 & VM28 Spigot	1.5	Brass	Left	Right	Narrow	A=30mm, B=33.5mm	2.05	VM28/56	<a href="#">003-010</a>
VM26 & VM28 Spigot	2.0	Brass	Left	Right	Narrow	A=30mm, B=33.5mm	2.05	VM28/56	<a href="#">003-011</a>
VM26 & VM28 Spigot	2.5	Brass	Left	Right	Narrow	A=30mm, B=33.5mm	2.05	VM28/56	<a href="#">003-012</a>
VM28 Clamp-On	2.0	Aluminum	Left	Right	Narrow	A=31.5mm, B=40.5mm	2.05	VM28/19	<a href="#">003-022</a>
VM28 Clamp-On	3.5	Aluminum	Left	Right	Narrow	A=31.5mm, B=40.5mm	2.05	VM28/19	<a href="#">003-025</a>
VM28 Clamp-On and: VM24 & VM30 Flange	0.5	Aluminum	Left	Right	Narrow	A=31.5mm, B=40.5mm	2.05	VM28/80	<a href="#">003-026</a>
VM24 & VM30 Flange	1.0	Aluminum	Left	Right	Narrow	A=31.5mm, B=40.5mm	2.05	VM28/80	<a href="#">003-027</a>
VM24 & VM30 Flange	2.0	Aluminum	Left	Right	Narrow	A=31.5mm, B=40.5mm	2.05	VM28/80	<a href="#">003-029</a>
VM24 & VM30 Flange	2.5	Aluminum	Left	Right	Narrow	A=31.5mm, B=40.5mm	2.05	VM28/80	<a href="#">003-030</a>
VM24 & VM30 Flange	3.5	Aluminum	Left	Right	Narrow	A=31.5mm, B=40.5mm	2.05	VM28/80	<a href="#">003-032</a>
VM28 Clamp-On and: VM28 & VM30 Flange	0.5	Aluminum	Right	Left	Narrow	A=31.5mm, B=40.5mm	2.05	VM28/81	<a href="#">003-033</a>
VM28 & VM30 Flange	1.0	Aluminum	Right	Left	Narrow	A=31.5mm, B=40.5mm	2.05	VM28/81	<a href="#">003-034</a>
VM28 & VM30 Flange	1.5	Aluminum	Right	Left	Narrow	A=31.5mm, B=40.5mm	2.05	VM28/81	<a href="#">003-035</a>
VM28 & VM30 Flange	2.0	Aluminum	Right	Left	Narrow	A=31.5mm, B=40.5mm	2.05	VM28/81	<a href="#">003-036</a>
VM28 & VM30 Flange	3.0	Aluminum	Right	Left	Narrow	A=31.5mm, B=40.5mm	2.05	VM28/81	<a href="#">003-038</a>
VM28 & VM30 Flange	3.5	Aluminum	Right	Left	Narrow	A=31.5mm, B=40.5mm	2.05	VM28/81	<a href="#">003-039</a>
VM24 & VM30 Flange	1.5	Aluminum	————	Right	Narrow	A=31.5mm, B=40.05mm	2.05	VM28/90	<a href="#">003-040</a>
VM24 & VM30 Flange	3.0	Aluminum	————	Right	Narrow	A=31.5mm, B=40.05mm	2.05	VM28/90	<a href="#">003-044</a>
Kaw. Z1/A-900 (73-74)	1.0	Aluminum	————	Right	Narrow	A=31.5mm, B=47.05mm	1.98	VM28/210	<a href="#">003-052</a>
Kaw. Z1/A-900 (73-74)	2.5	Aluminum	————	Right	Narrow	A=31.5mm, B=47.05mm	1.98	VM28/210	<a href="#">003-055</a>
Kaw. Z1/A-900 (73-74)	3.0	Aluminum	————	Right	Narrow	A=31.5mm, B=47.05mm	1.98	VM28/210	<a href="#">003-056</a>
Kaw. KZ900 (76-77) and: Kaw. Z1B-900 (1975)	1.0	Aluminum	————	Right	Narrow	A=31.5mm, B=47.5mm	1.98	VM28/490	<a href="#">003-057</a>
Kaw. Z1B-900 (1975)	1.5	Aluminum	————	Right	Narrow	A=31.5mm, B=47.5mm	1.98	VM28/490	<a href="#">003-058</a>
Kaw. Z1B-900 (1975)	2.0	Aluminum	————	Right	Narrow	A=31.5mm, B=47.5mm	1.98	VM28/490	<a href="#">003-059</a>
Kaw. Z1B-900 (1975)	2.5	Aluminum	————	Right	Narrow	A=31.5mm, B=47.5mm	1.98	VM28/490	<a href="#">003-060</a>
VM28 Clamp-On and: VM28 & VM30 Flange	2.5	Brass	Left	Right	Narrow	A=31.5mm, B=40.5mm	2.05	VM30/120	<a href="#">003-063</a>
VM28 & VM30 Flange	3.5	Brass	Left	Right	Narrow	A=31.5mm, B=40.5mm	2.05	VM30/120	<a href="#">003-172</a>
VM32, VM34 Flange and: VM30, 32, 34 Spigot	1.0	Aluminum	————	Right	Narrow	A=35.5mm, B=37.5mm	2.05	VM32/06	<a href="#">003-065</a>
VM30, 32, 34 Spigot	1.5	Aluminum	————	Right	Narrow	A=35.5mm, B=37.5mm	2.05	VM32/06	<a href="#">003-066</a>
VM32, VM34 Flange and: VM30, 32, 34 Spigot	0.5	Aluminum	Left	Right	Narrow	A=35.5mm, B=40.5mm	2.05	VM32/22	<a href="#">003-070</a>
VM30, 32, 34 Spigot	1.5	Aluminum	Left	Right	Narrow	A=35.5mm, B=40.5mm	2.05	VM32/22	<a href="#">003-072</a>
VM30, 32, 34 Spigot	3.0	Aluminum	Left	Right	Narrow	A=35.5mm, B=40.5mm	2.05	VM32/22	<a href="#">003-075</a>
VM32, VM34 Flange and: VM30, 32, 34 Spigot	3.5	Aluminum	Right	Left	Narrow	A=35.5mm, B=40.5mm	2.05	VM32/23	<a href="#">003-082</a>

# Mikuni VM Roundslide Throttle Valves

Application	Cutaway	Composition (material)	Idle Groove Position	Guide Pin Position	Guide Pin Groove Type	Dimension	G. Grv. Width	Mikuni No.	Order No.
VM30, 32, 34 Spigot	2.0	Brass	Right	Left	Wide	A=35.5mm, B=40mm	2.60	VM32/65	<a href="#">003-084</a>
VM30, 32, 34 Spigot	2.5	Brass	Right	Left	Wide	A=35.5mm, B=40mm	2.60	VM32/65	<a href="#">003-085</a>
VM30, 32, 34 Spigot	3.0	Brass	Right	Left	Wide	A=35.5mm, B=40mm	2.60	VM32/65	<a href="#">003-086</a>
VM30 Small Body Spigot	1.5	Brass	Left	Right	Wide	A=31.5mm, B=44.5mm	2.05	VM30/176	<a href="#">003-088</a>
VM30 Small Body Spigot	2.0	Brass	Left	Right	Wide	A=31.5mm, B=44.5mm	2.05	VM30/176	<a href="#">003-089</a>
VM30 Small Body Spigot	2.5	Brass	Left	Right	Wide	A=31.5mm, B=44.5mm	2.05	VM30/176	<a href="#">003-090</a>
VM30 Small Body Spigot	3.0	Brass	Left	Right	Wide	A=31.5mm, B=44.5mm	2.05	VM30/176	<a href="#">003-091</a>
VM32, VM34 Flange and:									
VM30, 32, 34, Spigot	1.0	Brass	Left	Right	Wide	A=35.5mm, B=40.5mm	2.60	VM34/110	<a href="#">003-098</a>
VM30, 32, 34, Spigot	1.5	Brass	Left	Right	Wide	A=35.5mm, B=40.5mm	2.60	VM34/110	<a href="#">003-099</a>
VM30, 32, 34, Spigot	2.0	Brass	Left	Right	Wide	A=35.5mm, B=40.5mm	2.60	VM34/110	<a href="#">003-100</a>
VM30, 32, 34, Spigot	2.5	Brass	Left	Right	Wide	A=35.5mm, B=40.5mm	2.60	VM34/110	<a href="#">003-101</a>
VM30, 32, 34, Spigot	3.0	Brass	Left	Right	Wide	A=35.5mm, B=40.5mm	2.60	VM34/110	<a href="#">003-102</a>
VM30, 32, 34, Spigot	3.5	Brass	Left	Right	Wide	A=35.5mm, B=40.5mm	2.60	VM34/110	<a href="#">003-103</a>
VM30, 32, 34, Spigot	2.0	Brass	Left	Right	Wide	A=35.5mm, B=40.5mm	2.60	VM34/354	<a href="#">003-177</a>
VM30, 32, 34, Spigot	2.5	Brass	Left	Right	Wide	A=35.5mm, B=40.5mm	2.60	VM34/354	<a href="#">003-178</a>
VM36 Spigot	0.5	Brass	Left	Right	Narrow	A=38mm, B=46mm	2.05	VM36/13	<a href="#">003-104</a>
VM36 Spigot	1.0	Brass	Left	Right	Narrow	A=38mm, B=46mm	2.05	VM36/13	<a href="#">003-105</a>
VM36 Spigot	1.5	Brass	Left	Right	Narrow	A=38mm, B=46mm	2.05	VM36/13	<a href="#">003-106</a>
VM36 Spigot	3.0	Brass	Left	Right	Narrow	A=38mm, B=46mm	2.05	VM36/13	<a href="#">003-109</a>
VM36 Spigot	3.5	Brass	Left	Right	Narrow	A=38mm, B=46mm	2.05	VM36/13	<a href="#">003-110</a>
VM36 Spigot	3.5	Brass	Right	Left	Narrow	A=38mm, B=46mm	2.05	VM36/18	<a href="#">003-116</a>
VM36 Spigot	3.5	Brass	Right	Left	Narrow	A=38mm, B=46mm	2.60	VM36/26	<a href="#">003-121</a>
VM36 Spigot	1.0	Brass	Left	Right	Wide	A=38mm, B=45.5mm	3.05	VM36/36	<a href="#">003-123</a>
VM36 Spigot	1.5	Brass	Left	Right	Wide	A=38mm, B=45.5mm	3.05	VM36/36	<a href="#">003-124</a>
VM36 Spigot	2.0	Brass	Left	Right	Wide	A=38mm, B=45.5mm	3.05	VM36/36	<a href="#">003-125</a>
VM36 Spigot	2.5	Brass	Left	Right	Wide	A=38mm, B=45.5mm	3.05	VM36/36	<a href="#">003-126</a>
VM36 Spigot	3.0	Brass	Left	Right	Wide	A=38mm, B=45.5mm	3.05	VM36/36	<a href="#">003-127</a>
VM36 Spigot	3.5	Brass	Left	Right	Wide	A=38mm, B=45.5mm	3.05	VM36/36	<a href="#">003-128</a>
VM36 Spigot	1.0	Brass	Right	Left	Wide	A=38mm, B=45.5mm	3.05	VM36/39	<a href="#">003-179</a>
VM36 Spigot	2.5	Brass	Right	Left	Wide	A=38mm, B=45.5mm	3.05	VM36/39	<a href="#">003-182</a>
VM36 Spigot	3.0	Brass	Right	Left	Wide	A=38mm, B=45.5mm	3.05	VM36/39	<a href="#">003-183</a>
VM36 Spigot	1.5	Brass	Left	Right	Wide	A=38mm, B=46mm	3.05	VM36/113	<a href="#">003-199</a>
VM36 Spigot	2.0	Brass	Left	Right	Wide	A=38mm, B=46mm	3.05	VM36/113	<a href="#">003-195</a>
VM38 Spigot	1.0	Brass	Right	Left	Narrow	A=39.5mm, B=45mm	2.05	VM38/02	<a href="#">003-130</a>
VM38 Spigot	3.0	Brass	Right	Left	Narrow	A=39.5mm, B=45mm	2.05	VM38/02	<a href="#">003-186</a>
VM38 Spigot	3.5	Brass	Right	Left	Narrow	A=39.5mm, B=45mm	2.05	VM38/02	<a href="#">003-187</a>
VM38 Spigot	3.5	Brass	Left	Right	Narrow	A=39.5mm, B=45.5mm	2.05	VM38/10	<a href="#">003-140</a>
VM38 Spigot	0.5	Brass	Right	Left	Wide	A=39.5mm, B=45.5mm	3.05	VM38/22	<a href="#">003-188</a>
VM38 Spigot	1.0	Brass	Right	Left	Wide	A=39.5mm, B=45.5mm	3.05	VM38/22	<a href="#">003-189</a>
VM38 Spigot	1.5	Brass	Right	Left	Wide	A=39.5mm, B=45.5mm	3.05	VM38/22	<a href="#">003-190</a>
VM38 Spigot	2.5	Brass	Right	Left	Wide	A=39.5mm, B=45.5mm	3.05	VM38/22	<a href="#">003-191</a>
VM38 Spigot	3.0	Brass	Right	Left	Wide	A=39.5mm, B=45.5mm	3.05	VM38/22	<a href="#">003-192</a>
VM38 Spigot	1.5	Brass	Right	Left	Wide	A=39.5mm, B=45mm	3.05	VM38/24	<a href="#">003-143</a>
VM38 Spigot	2.0	Brass	Right	Left	Wide	A=39.5mm, B=45mm	3.05	VM38/24	<a href="#">003-144</a>
VM38 Spigot	2.5	Brass	Right	Left	Wide	A=39.5mm, B=45mm	3.05	VM38/24	<a href="#">003-145</a>
VM38 Spigot	3.0	Brass	Right	Left	Wide	A=39.5mm, B=45mm	3.05	VM38/24	<a href="#">003-146</a>
VM38 Spigot	3.5	Brass	Right	Left	Wide	A=39.5mm, B=45mm	3.05	VM38/24	<a href="#">003-147</a>
VM38 Spigot	2.0	Brass	Left	Right	Wide	A=39.5mm, B=45mm	3.05	VM38/52	<a href="#">003-149</a>
VM38 Spigot	2.5	Brass	Left	Right	Wide	A=39.5mm, B=45mm	3.05	VM38/52	<a href="#">003-150</a>
VM38 Spigot	3.0	Brass	Left	Right	Wide	A=39.5mm, B=45mm	3.05	VM38/52	<a href="#">003-151</a>
VM38 Spigot	1.5	Aluminum	Right	Right	Wide	A=39.5mm, B=45.5mm	3.05	VM38/76	<a href="#">003-196</a>
VM38 Spigot	2.0	Brass	Left	Right	Wide	A=38mm, B=46.5mm	3.05	VM38/76	<a href="#">003-197A</a>
VM38 Spigot	3.0	Brass	Left	Right	Wide	A=38mm, B=46.5mm	3.05	VM38/76	<a href="#">003-197</a>
VM40 & VM44 Spigot	1.0	Aluminum	Left	Right	Wide	A=46mm, B=55.5	3.05	VM40/02	<a href="#">003-154</a>
VM40 & VM44 Spigot	1.5	Aluminum	Left	Right	Wide	A=46mm, B=55.5	3.05	VM40/02	<a href="#">003-155</a>
VM40 & VM44 Spigot	2.0	Aluminum	Left	Right	Wide	A=46mm, B=55.5	3.05	VM40/02	<a href="#">003-156</a>
VM40 & VM44 Spigot	2.5	Aluminum	Left	Right	Wide	A=46mm, B=55.5	3.05	VM40/02	<a href="#">003-157</a>
VM40 & VM44 Spigot	3.0	Aluminum	Left	Right	Wide	A=46mm, B=55.5	3.05	VM40/02	<a href="#">003-158</a>
VM40 & VM44 Spigot	1.5	Brass	Left	Right	Wide	A=46mm, B=56mm	3.05	VM44/23	<a href="#">003-162</a>
VM40 & VM44 Spigot	2.0	Brass	Left	Right	Wide	A=46mm, B=56mm	3.05	VM44/23	<a href="#">003-163</a>
VM40 & VM44 Spigot	2.5	Brass	Left	Right	Wide	A=46mm, B=56mm	3.05	VM44/23	<a href="#">003-164</a>
VM40 & VM44 Spigot	3.0	Brass	Left	Right	Wide	A=46mm, B=56mm	3.05	VM44/23	<a href="#">003-165</a>
VM40 & VM44 Spigot	3.5	Brass	Left	Right	Wide	A=46mm, B=56mm	3.05	VM44/23	<a href="#">003-166</a>



VINTAGE  
INTAKE  
ENGINE  
SUSPENSION  
CONTROL  
ELECTRICAL  
CHEMICAL  
TOOLS  
WATERCRAFT

<p><b>VM28/511 Viton Tip</b> <b>VM34/39 Metal Tip</b></p> <p>Size 511: 1.5, 1.8, 2.0, 2.5 Size: 39: 1.5, 2.5, 3.0, 3.3, 3.5 App: VM30-40</p>	<p><b>VM28/163 Metal Tip</b></p> <p>Size: 1.0, 1.2, 1.5, 1.8, 2.0, 2.5, 3.0 App: VM30-44</p>	<p><b>VM38/11 Metal Tip (6 hole)</b></p> <p>Size: 3.3, 3.5 App: VM30-44</p>	<p><b>VM26/26 Metal Tip</b></p> <p>Size: 1.0, 1.2, 1.5, 1.8, 2.0, 2.3, 2.5, 2.8 App: VM26, VM28 BN34, 38, 44</p>	<p><b>786-46001 Metal Tip</b></p> <p>Size: 1.2, 1.5, 1.8, 2.0, 3.0, 3.3, 3.5 App: TM32, 34, 36, 38 Flatslide</p>	<p><b>VM24/557 Metal Tip</b></p> <p>Size: 1.5, 2.0, 2.5 App: TM28 Flatslide</p>
<p><b>990-786-044</b></p> <p>Size: 3.8 App: HS40</p>	<p><b>786-35015 Viton Tip</b></p> <p>Size: 1.5, 1.8, 2.0, 2.3, 2.5 App: Super BN1 38, 44, 46</p>	<p><b>786-15005 Viton Tip</b></p> <p>Size: 1.5, 2.0, 2.5 App: BN34, 38, 44</p>	<p><b>N149.040 Metal Tip (Need O-Ring KV/10)</b></p> <p>Size: 2.0, 2.5, 2.8 App: RS34-40</p>	<p><b>VM15/172 Metal Tip</b></p> <p>Size: 1.2, 1.5, 1.8, 2.0 App: VM18, VM20</p>	<p><b>786-27001 Viton Tip</b></p> <p>Size: 1.5, 2.3, 3.5, 4.2 HSR42, 45, 48</p>
<p><b>N133.200 Viton Tip</b></p> <p>Size: 1.2, 1.5, 1.8, 2.0, 2.3 App: TM33, OEM Snowmobiles</p>	<p><b>786-35018 Viton Tip</b></p> <p>Size: 1.5, 2.0, 2.3, 2.5 App: BNI 46</p>	<p><b>786-36004-A</b></p> <p>Size: 1.8 App: TMX35, 38</p>	<p><b>786-36004</b></p> <p>Size: 3.5 App: TMX35, 38</p>		

## Genuine Mikuni Needle Valve Assemblies

Screw-in type includes Needle Valve and Needle Seat.(washer not included) Push-in type includes Needle Valve, Needle Seat O-Ring for Needle Seat (except RS Series) and Needle Valve Clip where applicable. **Made in Japan.** Order by Sudco part number.

### Applications: VM16, VM18 & VM20mm

Size	Application	Mikuni No.	Order No.
(1.5)	Std for VM16, 18 & 20mm	VM15/172	<b>007-288</b>
(2.0)		VM15/172	<b>007-289</b>
	Washer for Needle Valve Seat	VM15/07	<b>007-286</b>

### Applications: VM22mm - VM30mm Flange, VM24-512 Spigot, VM26 & VM28mm Round Spigot, VM30 Small Body

#### Round Pump Carb BN34, BN38 & BN44mm Watercraft

Size	Application	Mikuni No.	Order No.
(1.0)		VM26/26	<b>002-230</b>
(1.2)		VM26/26	<b>002-234</b>
(1.5)		VM26/26	<b>002-231</b>
(1.5)	Viton Tip	VM26/185	<b>002-232</b>
(2.0)		VM26/26	<b>002-189</b>
(2.5)		VM26/26	<b>002-190</b>
(2.8)		VM26/26	<b>002-191</b>
	Washer for Needle Valve Seat	VM26/25	<b>002-188</b>

### Applications: VM32 & VM34mm Flange VM30 - VM44mm Spigot

Size	Application	Mikuni No.	Order No.
(3.0)		VM34/39	<b>002-192</b>
(3.3)		VM34/39	<b>002-193</b>
(1.2)		VM28/163	<b>002-195</b>
(1.5)		VM28/163	<b>002-196</b>
(1.8)		VM28/163	<b>002-197</b>
(2.0)		VM28/163	<b>002-187</b>
(2.5)		VM28/163	<b>002-199</b>
	Washer for Needle Valve Seat	B34/52	<b>002-187</b>
(3.5)		VM38/11	<b>002-200</b>
(3.5)	OEM Yamaha 24X-14107-35-00	VM38/11	<b>002-200</b>

### Applications: VM30 - VM44mm - Snowmobile OEM (with viton tip needle)

Size	Application	Mikuni No.	Order No.
(1.5)		VM28/511	<b>002-233</b>
(1.8)		VM28/511	<b>002-895</b>
(2.0)		VM28/511	<b>002-896</b>



## Genuine Mikuni Needle Valve Assemblies (cont.)

### Applications: TM24, TM28 Flat Slide

Size	Application	Mikuni No.	Order No.
(1.5)	Std on TM24	VM24/557A	<b>002-842</b>
(2.0)		VM24/557A	<b>002-841</b>
(2.5)	Std on TM28	VM24/557A	<b>002-840</b>
	O-Ring for Needle Valve Seat	VM24/559	<b>002-838</b>

### Applications: TM32, TM34, TM36, TM38 Flat Slide

#### 39 & 41 Pro (No Accelerator Pump on carburetor)

Size	Application	Mikuni No.	Order No.
(1.5)		786-46001	<b>002-703</b>
(1.8)		786-46001	<b>002-702</b>
(2.0)		786-46001	<b>002-704</b>
(3.0)		786-46001	<b>002-706</b>
(3.3)	Std on TM32, TM34, TM36	786-46001	<b>002-705</b>
(3.5)	Std on TM38	786-46001	<b>002-707</b>
	O-Ring for Needle Valve Seat	KV-10	<b>002-709</b>

### Applications: Flatslide TMS38, Early Style TMX35, TMX38

Size	Application	Mikuni No.	Order No.
(1.8)		786-36004A	<b>002-464</b>
(3.5)		786-36004	<b>002-466</b>

### Applications: TMX38-2, TMX38-5 with Triangular Throttle Valve, Honda, Husqvarna, Kawasaki, Suzuki & Yamaha Later Style Triangular Throttle Valve OEM TMX36, TMX38

Size	Application	Mikuni No.	Order No.
(3.3)		786-36011	<b>007-954</b>
(3.8)		786-36010	<b>007-953</b>
	O-Ring for Needle Valve Seat	KV-10	<b>002-709</b>

### Applications: TM33 with Accelerator Pump Suzuki OEM DR250/DR350 Offroad with Mikuni TM33 (90-99)

Size	Application	Mikuni No.	Order No.
(1.5)		N133.200	<b>007-501</b>
(1.8)	Std on TM33	N133.200	<b>007-502</b>
(2.0)		N133.200	<b>007-503</b>
(2.3)		N133.200	<b>007-504</b>
	O-Ring for Needle Valve Seat	KV-10	<b>002-709</b>
	Filter for Needle Valve Seat	VM18/233	<b>002-606</b>

### Applications: HS40, TM36-68 & TM40-6 (With Accelerator Pump)

Size	Application	Mikuni No.	Order No.
(3.3)	Std on TM36-68	786-36011	<b>007-505</b>
(3.8)	Std on TM40-6	990-786-044	<b>002-877</b>
	O-Ring for Needle Valve Seat	KV-10	<b>002-709</b>

### Applications: HSR42, HSR45 & HSR48 (with viton tip needle)

Size	Application	Mikuni No.	Order No.
(2.3)		786-27001	<b>007-478</b>
(3.5)		786-27001	<b>007-477</b>
(4.2)	Std on HSR42/45	786-27001	<b>007-476</b>
(4.5)	Std on HSR48 (no o-ring)	786-27002-1A	<b>007-708</b>
	O-ring for Needle Valve Seat	616-33003	<b>007-470</b>

### Applications: RS34, RS36, RS38 & RS40 (O-Ring for needle valve seat not included)

Size	Application	Mikuni No.	Order No.
(2.0)		N149.040	<b>007-143</b>
(2.5)		N149.040	<b>007-144</b>
(2.8)	Std on all RS Series	N149.040	<b>007-145</b>
	O-Ring for Needle Valve Seat	KV-10	<b>002-709</b>
	Filter for Needle Valve Seat	VM18/233	<b>002-606</b>

### Applications: VM29 & VM33 Smoothbore

Size	Application	Mikuni No.	Order No.
(2.5)		N122.032	<b>002-503</b>
(2.8)	Std on VM29 & VM33	N122.032	<b>002-504</b>
	Washer for Needle Valve Seat	BS34/52-0.5	<b>002-187</b>
	Filter for Needle Valve Seat	VM18/233	<b>002-606</b>

### Applications: BN34, BN38 & BN44mm Watercraft with Round Pump Carb

Size	Application	Mikuni No.	Order No.
(1.0)		VM26/26	<b>002-230</b>
(1.2)		VM26/26	<b>002-234</b>
(1.5)		VM26/26	<b>002-231</b>
(1.5)	Viton Tip	VM26/185	<b>002-232</b>
(2.0)		VM26/26	<b>002-189</b>
(2.5)		VM26/26	<b>002-190</b>
(2.8)		VM26/26	<b>002-191</b>
	Washer for Needle Valve Seat	VM26/25	<b>002-188</b>

### Applications: BN34, BN38 & BN44mm Watercraft

Size	Application	Mikuni No.	Order No.
1.5		786-15005	<b>002-890</b>
2.0		786-15005	<b>002-891</b>
2.5		786-15005	<b>002-892</b>
	Washer for Needle Valve Seat	VM26/25	<b>002-188</b>

### Applications: Super BN 38, BN44 and BN46 Watercraft Super BN38I, BN40I Watercraft

Size	Application	Mikuni No.	Order No.
1.5		786-35015	<b>002-880</b>
1.8		786-35015	<b>002-884</b>
2.0		786-35015	<b>002-881</b>
2.3		786-35015	<b>002-882</b>
2.5		786-35015	<b>002-883</b>
	O-Ring for Needle Valve Seat	KV-10	<b>002-709</b>

### Applications: Super BN44I, BN46I

Size	Application	Mikuni No.	Order No.
1.5		786-35018	<b>002-900</b>
1.8		786-35018	<b>002-897</b>
2.0		786-35018	<b>002-898</b>
2.5		786-35018	<b>002-899</b>
	O-Ring for Needle Valve Seat	KV-10	<b>002-709</b>



## Genuine Mikuni Needle Valve Seat Filter

Used on the following Mikuni carburetors: RS34, RS36, RS38 & RS40 Smoothbore, VM29, VM33 Smoothbore, TM33 Pumper and OEM push type needle valve assembly. Sold each. Needle Valve Assembly not included. *Made in Japan.*

Order No. **002-606**

### OEM reference for Needle Valve Seat Filter

Kawasaki 14043-1010	Late model KZ1000/1100
Suzuki 13376-19F00	GS series - GS750/1000/1100
Yamaha 1J7-14994-00-00	XS1100 Series

**VM22/210**

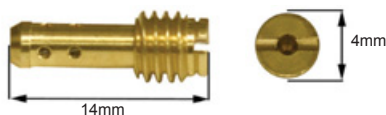

**Applications:** VM18 clamp-on, VM22 flange, VM26-8074, VM26 - VM34 flange, VM24 -VM44 spigot, TM series TM24 - TM38 (no Accelerator pump), early TMS/TMX Carburetors, OEM **Kawasaki, Suzuki, Yamaha** 2-stroke and some 4-stroke models.  
**Note:** VM26-606 spigot, use M28/1001 pilot jets.

Size	Order No.	Size	Order No.	Size	Order No.
#10	004-000	#37.5	004-594	#70	004-016
#12.5	004-001	#40	004-010	#75	004-017
#15	004-002	#42.5	004-733	#80	004-018
#17.5	004-003	#45	004-011	#85	004-067
#20	004-004	#47.5	004-734	#90	004-068
#22.5	004-005	#50	004-012	#95	004-069
#25	004-006	#52.5	004-735	#100	004-590
#27.5	004-007	#55	004-013	#110	004-591
#30	004-008	#57.5	004-736	#120	004-592
#32.5	004-593	#60	004-014	#130	004-737
#35	004-009	#65	004-015	#140	004-738

**BS30/96 (Bleed Type)**

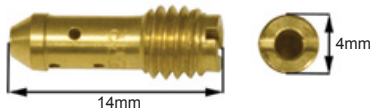

**Applications:** Kawasaki, Suzuki, Yamaha. with OEM (BS) CV Carburetors.

Size	Order No.	Size	Order No.	Size	Order No.
#30	004-054	#42.5	004-059	#55	004-064
#32.5	004-055	#45	004-060	#57.5	004-065
#35	004-056	#47.5	004-061	#60	004-066
#37.5	004-057	#50	004-062		
#40	004-058	#52.5	004-063		

**M28/1001**

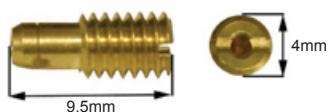

**Applications:** VM20 flange, VM26-606 spigot. **Kawasaki** KX65, **Suzuki** RM65, **Yamaha** RX50 Special (83-84), YSR50 (87-92), RD60 (73-74), YZ80 (75-01), DT125 (74-81), DT175 (74-81), MX175 (79-81), YFS200 Blaster (88-06), RZ350 (84-85), YFZ350 Banshee (87-06).

Size	Order No.	Size	Order No.	Size	Order No.
#15	004-039	#32.5	004-597	#50	004-046
#17.5	004-050	#35	004-043	#52.5	004-601
#20	004-040	#37.5	004-598	#55	004-047
#22.5	004-595	#40	004-044	#57.5	004-602
#25	004-041	#42.5	004-599	#65	004-049
#27.5	004-596	#45	004-045	#70	004-603
#30	004-042	#47.5	004-600		

**N151.067 (Non Bleed Type)**

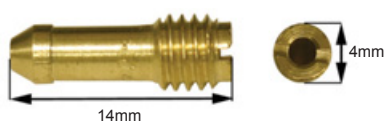

**Applications:** Late model OEM (BS) CV Carburetors. **Kawasaki** KZ1000J/K/M/P/R, KZ1100, **Suzuki** GSF600 Bandit up to 2001, DR650, GS1000, GS1100, GSX-R1100W (93-98) **Yamaha** YFM350 Warrior, FJ1100, XS1100.

Size	Order No.	Size	Order No.	Size	Order No.
#30	004-605	#42.5	004-610	#55	004-615
#32.5	004-606	#45	004-611	#57.5	004-616
#35	004-607	#47.5	004-612	#60	004-617
#37.5	004-608	#50	004-613		
#40	004-609	#52.5	004-614		

**VM28/486**

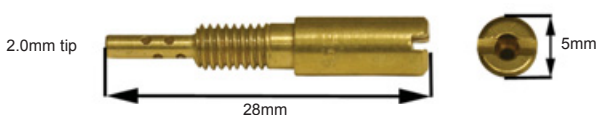

**Applications:** HS40, HSR42/45/48, RS34 - RS40 and TM33, TM36, TM40 with accelerator pump, **Kawasaki** Z1A/B-900 (74-75), KZ900A/B (76-77), KZ1000 (77-80), **Suzuki** DR-Z125, RM250 (89-92) GS750, GS1100 (78-79), **Yamaha** YFM80 Raptor 80, TT-R125.

Size	Order No.	Size	Order No.	Size	Order No.
#10	004-556	#32.5	004-557	#55	004-560
#12.5	004-027	#35	004-035	#57.5	004-552
#15	004-028	#37.5	004-555	#60	004-561
#17.5	004-029	#40	004-036	#62.5	004-553
#20	004-030	#42.5	004-051	#65	004-562
#22.5	004-031	#45	004-037	#67.5	004-554
#25	004-032	#47.5	004-052	#70	004-563
#27.5	004-033	#50	004-038		
#30	004-034	#52.5	004-551		

**Slow Speed Jets N100.606**

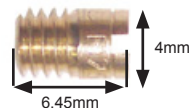

**Applications:** Slow Speed Jet on BN Personal Watercraft Carburetors. Super BN 38, BN44, BN46, BN38I, BN40I, BN44I, BN46I. Pilot Jet for **Kawasaki** KZ1300A (79-82) and Main Jet for **Yamaha** Generator (1HX).

Size	Order No.	Size	Order No.	Size	Order No.
#30	004-442	#77.5	004-461	#120	004-478
#32.5	004-443	#80	004-462	#122.5	004-479
#35	004-444	#82.5	004-463	#125	004-480
#37.5	004-445	#85	004-464	#127.5	004-481
#40	004-446	#87.5	004-465	#130	004-482
#42.5	004-447	#90	004-466	#132.5	004-483
#45	004-448	#92.5	004-467	#135	004-484
#47.5	004-449	#95	004-468	#137.5	004-485
#50	004-450	#97.5	004-469	#140	004-486
#52.5	004-451	#100	004-470	#142.5	004-487
#55	004-452	#102.5	004-471	#145	004-488
#57.5	004-453	#105	004-472	#147.5	004-489
#60	004-454	#107.5	004-473	#150	004-490
#62.5	004-455	#110	004-474	#155	004-491
#65	004-456	#112.5	004-475	#160	004-492
#67.5	004-457	#115	004-476		
#70	004-458	#117.5	004-477		
#72.5	004-459				
#75	004-460				

## N224.103

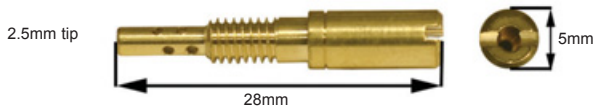

**Applications:** TMR, TMX late, OEM TMX36, TMX38, OEM BSR CV  
Honda CR125R (00-07), CR250R (01-07),

Kawasaki KX125 (00-05), KSF400 "KFX" (03-06), Polaris Predator,  
Suzuki RM125 (00-07), LT-Z400 (03-07), SV650, GSF600 Bandit 02-up  
Yamaha YZ125 (95-07), YFM250 Raptor 250, YFM350 Raptor (04-07),  
YFM660 Raptor (01-05), YXR660 Rhino Side x Side (04-07), YZF-R1, FZ1.

Size	Order No.	Size	Order No.	Size	Order No.
#10	004-580	#32.5	004-569	#55	004-575
#12.5	004-581	#35	004-570	#57.5	004-587
#15	004-582	#37.5	004-571	#60	004-576
#17.5	004-583	#40	004-572	#65	004-577
#20	004-564	#42.5	004-584	#70	004-578
#22.5	004-565	#45	004-573		
#25	004-566	#47.5	004-585		
#27.5	004-567	#50	004-574		
#30	004-568	#52.5	004-586		

## BS30/97 Air Jet

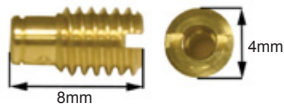

Meters the air flow through the passage to and into the needle jet.  
It acts as a fine tuning component in regulating the fuel-air mixture.  
This is especially important when a bleed type needle jet is used.

**Applications:** VM26 thru VM44 spigot carburetor, RS, TM,  
VM29/VM33 Smoothbore.

Size	Order No.	Size	Order No.	Size	Order No.
#0.0	002-149	#1.0	002-155	#1.6	002-161
#0.5	002-150	#1.1	002-156	#1.7	002-162
#0.6	002-151	#1.2	002-157	#1.8	002-163
#0.7	002-152	#1.3	002-158	#1.9	002-164
#0.8	002-153	#1.4	002-159	#2.0	002-165
#0.9	002-154	#1.5	002-160		

## B42/55 Air Jet



**Applications:** OEM CV (BS) Carburetors, Pilot Air Jet and Main Air  
Jet for OEM Suzuki GS1000, GS1100 (80-82),  
OEM Yamaha XS1100 (80-81).

Size	Order No.	Size	Order No.	Size	Order No.
#70	004-640	#145	004-655	#210	004-668
#80	004-642	#150	004-656	#220	004-670
#90	004-644	#155	004-657	#230	004-672
#100	004-646	#160	004-658	#240	004-674
#105	004-647	#165	004-659	#250	004-676
#110	004-648	#170	004-660	#260	004-678
#115	004-649	#175	004-661	#270	004-680
#120	004-650	#180	004-662	#280	004-682
#125	004-651	#185	004-663	#290	004-684
#130	004-652	#190	004-664	#300	004-686
#135	004-653	#195	004-665		
#140	004-654	#200	004-666		

## VM28/213



Size	Order No.	Size	Order No.	Size	Order No.
#15	004-019	#22.5	004-022	#35	004-025
#17.5	004-020	#25	004-023	#40	004-026
#20	004-021	#30	004-024		

## Starter Jet VM17/1002

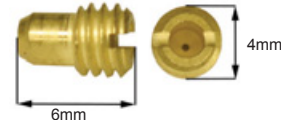

Controls enricher on TM Carburetors.

**Applications:** TM32 - TM38 Carburetors, RS Smoothbore.

Size	Order No.	Size	Order No.	Size	Order No.
#15	004-400	#40	004-406	#80	004-414
#20	004-402	#60	004-410	#100	004-418

## N101.043

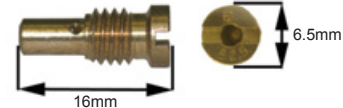

**Applications:** B-Type Butterfly Carb.

Size	Order No.	Size	Order No.	Size	Order No.
#30	004-501	#65	004-515	#97.5	004-528
#35	004-503	#67.5	004-516	#100	004-529
#37.5	004-504	#70	004-517	#105	004-531
#40	004-505	#72.5	004-518	#110	004-533
#42.5	004-506	#75	004-519	#115	004-534
#45	004-507	#77.5	004-520	#120	004-535
#47.5	004-508	#80	004-521	#125	004-536
#50	004-509	#82.5	004-522	#130	004-537
#52.5	004-510	#85	004-523	#135	004-538
#55	004-511	#87.5	004-524	#140	004-539
#57.5	004-512	#90	004-525	#145	004-540
#60	004-513	#92.5	004-526	#150	004-541
#62.5	004-514	#95	004-527	#155	004-542
				#160	004-543

## Sudco Plastic Jet Boxes (Storage Boxes)

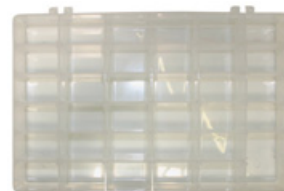

008-001

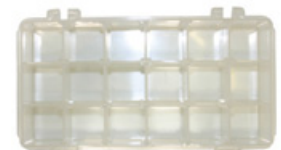

008-002

Two boxes available, 36 compartment and 18 compartment.  
Use for storing valve shims, small parts, electrical connectors  
and carburetor jets. Sold each.

Description	Order No.
Box with 36 compartments. 7-1/2" L x 10-1/2" L x 1-1/4" H	008-001
Box with 18 compartments. 3-1/2" L x 6-3/4" L x 1-1/2" H	008-002

## Mikuni Dealer Main Jet Kits



Genuine OEM N100.604 large round main jets.

*Made in Japan.*

### Mikuni Dealer Main Jet Kit, sizes #50 - #105.

**Order No. 004-995**

Kit Includes qt 4 of the following main jet sizes:

#50, #52.5, #55, #57.5, #60, #62.5, #65, #67.5, #70, #72.5, #75, #77.5, #80, #82.5, #85, #87.5, #90, #92.5, #97.5, #100, #105.

Total jets: 88 with storage box.

### Mikuni Dealer Main Jet Kit, sizes #107.5 - #160.

**Order No. 004-996**

Kit Includes qt 4 of the following main jet sizes:

#107.5, #110, #112.5, #115, #117.5, #120, #122.5, #125, #127.5, #130, #132.5, #135, #137.5, #140, #142.5, #145, #147, #150, #152.5, #155, #157.5, #160.

Total jets: 88 with storage box.

### Mikuni Dealer Main Jet Kit, sizes #162.5 - #240.

**Order No. 004-997**

Kit Includes qt 4 of the following main jet sizes:

#162.5, #165, #167.5, #170, #172.5, #175, #177.5, #180, #182.5, #185, #187.5, #190, #192.5, #195, #200, #205, #210, #220, #230, #240.

Total jets: 88 with storage box.

## Large Round N100.604

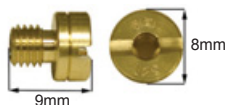

**Applications:** VM16, HS40, HSR42/45/48, RS, TM33 Pumper, TM36, TM40, TM, VM29/VM33 Smoothbore, Needle Jet Series - 171, 188, 196 with Large Round, **Kawasaki** H1-500 (all), H2-750 (all), Z1-900, KZ900A/B, (76-77), KZ1000, KZ1100, **Suzuki** DR-Z125, GS450/500 /650/750/850/1000/1100/1150, **Yamaha** TTR125, XS350/400/750/1100 and many 2-stroke & 4-stroke Street, ATV, Offroad, YFM250 Raptor 250.

Size	Order No.	Size	Order No.	Size	Order No.
#50	004-160	#105	004-182	#160	004-204
#52.5	004-161	#107.5	004-183	#162.5	004-205
#55	004-162	#110	004-184	#165	004-206
#57.5	004-163	#112.5	004-185	#167.5	004-207
#60	004-164	#115	004-186	#170	004-208
#62.5	004-165	#117.5	004-187	#172.5	004-209
#65	004-166	#120	004-188	#175	004-210
#67.5	004-167	#122.5	004-189	#177.5	004-211
#70	004-168	#125	004-190	#180	004-212
#72.5	004-169	#127.5	004-191	#182.5	004-213
#75	004-170	#130	004-192	#185	004-214
#77.5	004-171	#132.5	004-193	#187.5	004-215
#80	004-172	#135	004-194	#190	004-216
#82.5	004-173	#137.5	004-195	#192.5	004-217
#85	004-174	#140	004-196	#195	004-218
#87.5	004-175	#142.5	004-197	#200	004-220
#90	004-176	#145	004-198	#205	004-222
#92.5	004-177	#147.5	004-199	#210	004-223
#95	004-178	#150	004-200	#215	004-353
#97.5	004-179	#152.5	004-201	#220	004-350
#100	004-180	#155	004-202	#230	004-351
#102.5	004-181	#157.5	004-203	#240	004-352

## Mikuni Dealer Main and Pilot Jet Kit



Genuine OEM 4/042 large hex main jets and N224.103 pilot jets.

*Made in Japan.*

### Mikuni Dealer Main and Pilot Jet Kit, sizes #350 - #500 Main Jets and sizes #32.5 - #65 Pilot Jets.

**Order No. 004-999**

Kit Includes qt 2 of the following jet sizes:

**Main Jets:** #350, #360, #370, #380, #390, #400, #410, #420, #430, #440, #450, #460, #470, #480, #490, #500.

**Pilot Jets:** #32.5, #35, #37.5, #40, #45, #50, #55, #60, #60.

Total jets: 50 with storage box.

## Large Hex 4/042

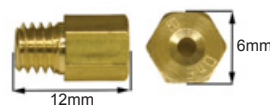

**Applications:** VM18 Clamp-On, VM24-512, VM26-606, OEM TMX Late Series, Needle Jet Series - 159, 176, 183, 188, 192, 193, 205, 211, 224 with 4/042 hex main, **Honda** CR125R (00-07), CR250R (01-07), **Husqvarna** CR/WR125/250, **Kawasaki** KX125 (00-05), **Suzuki** RM125 (00-07), **Yamaha** YZ125 (95-08), RD350/400, YFZ350 Banshee (87-06) and many 2-stroke ATV and Offroad, **Polaris** Snowmobile 400XC/XCR with Mikuni TMX and **Polaris** 2-stroke ATV with VM carburetor.

Size	Order No.	Size	Order No.	Size	Order No.
#50	004-070	#175	004-095	#390	004-124
#55	004-071	#180	004-100	#400	004-125
#60	004-072	#185	004-101	#410	004-126
#65	004-073	#190	004-102	#420	004-127
#70	004-074	#195	004-103	#430	004-128
#75	004-075	#200	004-104	#440	004-129
#80	004-076	#210	004-105	#450	004-130
#85	004-077	#220	004-106	#460	004-131
#90	004-078	#230	004-107	#470	004-132
#95	004-079	#240	004-108	#480	004-133
#100	004-080	#250	004-109	#490	004-134
#105	004-081	#260	004-110	#500	004-135
#110	004-082	#270	004-111	#540	004-139
#115	004-083	#280	004-112	#560	004-141
#120	004-084	#290	004-113	#580	004-143
#125	004-085	#300	004-115	#600	004-145
#130	004-086	#310	004-116	#620	004-146
#135	004-087	#320	004-117	#640	004-147
#140	004-088	#330	004-118	#660	004-149
#145	004-089	#340	004-119	#680	004-150
#150	004-090	#350	004-120	#700	004-151
#155	004-091	#360	004-121	#720	004-153
#160	004-092	#370	004-122		
#165	004-093	#380	004-123		
#170	004-094				

## Keihin/Mikuni Main Jet Wrench

Sold each. **Order No. 002-401**



## Small Round N102.221



**Applications:** Personal Watercraft (High Speed Jets) Super BN 38, BN44, BN46, BN38I, BN40I, BN44I, BN46I, Needle Jet Series 171, 188, 196. with small round. Arctic Cat DS650, Kawasaki KSF400 "KXF" (03-06), Polaris Predator and Outlaw 500 with Mikuni BSR carburetor, Suzuki ALT50 (1983), LT50 (84-87), LT-A50 (02-05), LT-Z400, DR-Z400 with Mikuni carb, SV650, Yamaha Generator (3G2), YFM660 Raptor, YXR660 Rhino Side x Side.

Size	Order No.	Size	Order No.	Size	Order No.
#30	004-333	#92.5	004-282	#155	004-307
#32.5	004-334	#95	004-283	#157.5	004-308
#35	004-335	#97.5	004-284	#160	004-309
#37.5	004-336	#100	004-285	#162.5	004-310
#40	004-337	#102.5	004-286	#165	004-311
#42.5	004-338	#105	004-287	#167.5	004-312
#45	004-339	#107.5	004-288	#170	004-313
#47.5	004-340	#110	004-289	#172.5	004-314
#50	004-255	#112.5	004-290	#175	004-315
#52.5	004-256	#115	004-291	#177.5	004-316
#55	004-267	#117.5	004-292	#180	004-317
#57.5	004-268	#120	004-293	#182.5	004-318
#60	004-269	#122.5	004-294	#185	004-319
#62.5	004-270	#125	004-295	#187.5	004-320
#65	004-271	#127.5	004-296	#190	004-321
#67.5	004-272	#130	004-297	#195	004-323
#70	004-273	#132.5	004-298	#200	004-325
#72.5	004-274	#135	004-299	#205	004-326
#75	004-275	#137.5	004-300	#210	004-327
#77.5	004-276	#140	004-301	#215	004-328
#80	004-277	#142.5	004-302	#220	004-329
#82.5	004-278	#145	004-303	#230	004-330
#85	004-279	#147.5	004-304	#240	004-331
#87.5	004-280	#150	004-305		
#90	004-281	#152.5	004-306		

## Large Thread VM11/22



**Applications:** Suzuki LT-Z50 (06-07), LT-Z90 (2007), Yamaha YFM50 Raptor, YFM80 Grizzly 80, YFM80 Badger, YFM80 Raptor, TTR90 (00-07).

Size	Order No.	Size	Order No.	Size	Order No.
#50	004-740	#80	004-752	#130	004-764
#52.5	004-741	#82.5	004-753	#135	004-765
#55	004-742	#85	004-754	#140	004-766
#57.5	004-743	#87.5	004-755	#145	004-767
#60	004-744	#90	004-756	#150	004-768
#62.5	004-745	#95	004-757	#155	004-769
#65	004-746	#100	004-758	#160	004-770
#67.5	004-747	#105	004-759	#165	004-771
#70	004-748	#110	004-760	#170	004-772
#72.5	004-749	#115	004-761	#175	004-773
#75	004-750	#120	004-762	#180	004-774
#77.5	004-751	#125	004-763		

## Motion Pro Main Jet Wrenches

These high quality, die cast construction wrenches have a rubber snap-off lid on body for storage of extra jets. Sold each.

Description	Order No.
6mm Round	950-417
6mm Hex	950-415
8mm Hex	950-416

## Small Hex M10/14

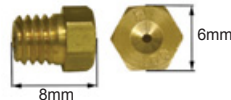

**Applications:** Early Kawasaki rotary valve, 2-stroke singles and Yamaha small bore, 2-stroke singles.

Size	Order No.	Size	Order No.	Size	Order No.
#40	004-360	#105	004-235	#160	004-246
#50	004-224	#110	004-236	#165	004-247
#55	004-225	#115	004-237	#170	004-248
#60	004-226	#120	004-238	#175	004-249
#65	004-227	#125	004-239	#180	004-250
#70	004-228	#130	004-240	#185	004-251
#75	004-229	#135	004-241	#190	004-252
#80	004-230	#140	004-242	#195	004-253
#85	004-231	#145	004-243	#200	004-254
#90	004-232	#150	004-244		
#95	004-233	#155	004-245		
#100	004-234				

## Press-In N208.099



**O-Ring**  
007-790  
Sold separate

**Applications:** Ducati late model CV and Yamaha YZF750 OEM BDST Carburetors (downdraft).

Size	Order No.	Size	Order No.	Size	Order No.
#110	004-700	#130	004-708	#150	004-716
#112.5	004-701	#132.5	004-709	#155	004-718
#115	004-702	#135	004-710	#160	004-720
#117.5	004-703	#137.5	004-711	#165	004-722
#120	004-704	#140	004-712	#170	004-724
#122.5	004-705	#142.5	004-713	#175	004-726
#125	004-706	#145	004-714	#190	004-727
#127.5	004-707	#147.5	004-715		



## Sudco Jet Carrier

Stores 20 main jets, 6 pilot jets (Keihin & Mikuni) and 3 jet needle. Keihin PE, PJ, PWK, PWM jet needle and Mikuni 4, 5, and 6 series. Jets not included.

Order No. 002-405



# Mikuni Fuel Pumps & Rebuild Kits



DF44-211



DF52-136



DF52-21



DF52-73



DF52-92



DF62-702

## Mikuni Pulse Fuel Pumps

Mikuni Pulse Fuel Pumps employ an engine's fluctuating engine crankcase pressure to pump fuel from a remote fuel tank to an engine's carburetor(s). Applications include Personal Watercraft and Snowmobiles. Sold each.

Mikuni No.	Number of Outlets	Style	Mounting	Flow Rate Liter/Hour	Order No. Fuel Pump	Order No. Rebuild Kit
DF44-211 (DF44-227)	1	Square	Flush	14	002-220	002-225
D52-21 (DF52-176)	2	Round	Bracket	35	002-221	002-223
DF52-73	2	Round	Flush	35	002-228	002-223
DF52-92	3	Round	Flush	35	002-229	002-223
DF52-136	2	Square	Flush	31	002-222	002-226
DF62-702	2	Pentagon	Flush	65	002-227	002-226



002-225



002-223

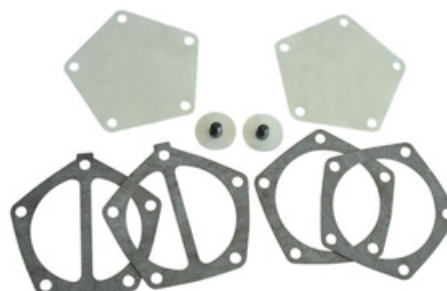

002-226

## Mikuni Fuel Pump Rebuild Kits

Sold in kits. See contents listing for parts in each kit.

Mikuni Kit No. MK-DF44      Order No. **002-225**  
Fits DF44 Fuel Pump.

Contents	Description	Qt.	Remarks
CW2=0416	Screw	4	with lock washer
DF44-201/03	Gasket	1	Fiber
DF44-201/04	Diaphragm	1	Clear
DF44-201/05	Membrane	1	Thin Rubber

Mikuni Kit No. MK-DF52      Order No. **002-223**  
Fits ALL DF52 Fuel Pumps except DF52-136.

Contents	Description	Qt.	Remarks
DF52-105	Gasket	1	Thick Fiber
DF52-48/10	Diaphragm	2	Transparent Film
DF52-48/05	Gasket	1	Thin Rubber
DF52/113	Gasket	1	Thin Rubber
DF52/36A	Gasket	1	Thick Fiber
DF52/27A	Valve	2	Clear
DF44/26	Grommet	2	Black

**Note: Fuel Pump Rebuild Kit for DF52-136 is not available.**

Mikuni Kit No. MK-DF62      Order No. **002-226**  
Fits DF62 Fuel Pump

Contents	Description	Qt.	Remarks
DF62-601/03	Gasket	2	Paper Gasket
DF62-601/04	Diaphragm	2	Clear
DF62-701/03	Gasket	2	Paper Gasket
DF62-701/05	Check Valve	2	Clear Grommet



## YXR660 Rhino Fuel Pump Rebuild Kit

Mikuni Kit No. MK-DF52-531      Order No. **002-224**  
Fits Yamaha OEM Fuel Pump for YXR450/YXR660 Rhino side x side.

# Air Box Adapters & Manifold Adapters

VINTAGE INTAKE ENGINE SUSPENSION CONTROL ELECTRICAL CHEMICAL TOOLS WATERCRAFT



005-044



005-013



005-038



005-026



005-848

## Honda

Model	Year	Description	Reference	Carb	Qt	Order No.
FL250 Odyssey	77-84	Manifold	SM-49A	30, 32, 34, 36, 38	each	005-052
FL250 Odyssey	77-84	Rubber Flange	M-VM-34-200K	30, 32, 34	each	002-053
FL250 Odyssey	77-84	Rubber Flange	M-VM-36-200K	36, 38	each	002-054
TRX250X		Air Box Adapter	—	VM30 - 34/TM36	each	005-075
XR250R	84-85	Manifold	SM-56		each	005-067
XR250R	84-85	Rubber Flange	M-VM-34-200K		each	002-053
XR250R	84-85	Air Box Adapter	—		each	005-077
XR350R	83-84	Manifold	SM-56		each	005-067
XR350R	83-84	Rubber Flange	M-VM-34-200K		each	002-053
XR350R	83-84	Air Box Adapter	—		each	005-077
XR400R	96-04	Air Box Adapter	—	TM36	each	005-078
XR650R	00-07	Air Box Adapter	—	TM40	each	005-820
XR650R	00-07	Intake Spigot	XR-05	TM40	each	005-822
CB750 SOHC (pre 1979)	69-78	Intake Manifolds	VM29/A2HSM	VM29 Smoothbore	set 4	005-026

## Harley Davidson®

Sportster® 900/1000		Manifold with hose	SM-7	VM36, 38	each	005-013
Shovelhead		Manifold with hose	SM-7	VM36, 38	each	005-013
Knucklehead, Panhead		Manifold	SM-9	VM36, 38	each	005-015
Knucklehead, Panhead		Manifold	SM-10	VM40, 44	each	005-016
Evo Adapter Ring	1990 on		MK-413	TM40 (HS40)	each	005-095

## Norton

Atlas (Single Carb)		Manifold		VM30, 32, 34	each	005-088
Atlas (Single Carb)		Rubber Flange	M-VM-34-200K	VM30, 32, 34	each	002-053
Commando 750/850 (Single Carb)		Manifold	SM-23	VM32, 34	each	005-037
Commando 750/850 (Single Carb)		Rubber Flange	M-VM-34-200K	VM32, 34	each	002-053
Commando 750/850 (Single Carb)		Manifold	SM-23A	VM36, 38	each	005-038
Commando 750/850 (Single Carb)		Rubber Flange	M-VM-36-200K	VM36, 38	each	002-054
Commando 750/850 (Dual Carb)		Manifold	SM-18	VM30, 32, 34	each	005-036
Commando 750/850 (Dual Carb)		Rubber Flange	M-VM-34-200K	VM30, 32, 34	each	002-053

## Triumph

Bonneville (Flange Mount)	72-78	Manifold	SM-44	VM30, 32, 34	pair	005-060
Bonneville (fine Thread pitch 20)	63-68	Manifold with hose	SM-14	VM30, 32, 34	pair	005-044
Bonneville (coarse Thread pitch 16)	Mid 69-72	Manifold with hose	SM-13	VM30, 32, 34	pair	005-043
Bonneville	Mid 72-78	Manifold	SM-44	VM30, 32, 34	each	005-060A
TR6, TR7 single	up to 1981	Manifold	SM-43	VM30, 32, 34	each	005-045
TR6, TR7 single	up to 1981	Rubber Flange	M-VM-34-200K	VM30, 32, 34	each	002-053

## Yamaha

YFZ350 Banshee	87-06	Manifold only			each	005-847
YFZ350 Banshee	87-06	Manifold with VM28/200 Flanges	(002-050)	26 - 28	kit	005-848
YFZ350 Banshee	87-06	Manifold with VM34/200 Flanges	(002-053)	30 - 35	kit	005-849
XS650	all	Intake Flange with clamps		VM34	kit	005-815
XS650	all	Intake Flange only		VM34	each	005-815A



Honda ATC/TRX250R



Yamaha YFS200 Blaster



Yamaha YFZ350 Banshee Carb Boots

## UPP ATV Intake Manifolds

Made of polyurethane. Stronger, tougher and more durable than products made with conventional elastomers and plastic. No cracking or ripping with these bullet proof manifolds. Outperforms the stock rubber manifolds. Sold in pairs and each as noted.

### Honda ATV

Model	Year	Carb Application	Qt	Order No.
ATC250R	85-86	Stock	each	005-830
ATC250R	85-86	PWK 38 - 39mm	each	005-831
TRX250R	86-89	Stock	each	005-830
TRX250R	86-89	PWK 38 - 39mm	each	005-831



Yamaha YFZ350 Banshee

### Yamaha ATV (UPP cont.)

Model	Year	Carb Application	Qt	Order No.
YFS200 Blaster	88-06	Stock	each	005-840
YFS200 Blaster	88-06	PJ34, PWK33 - 35 TM34	each	005-841
YFZ350 Banshee	87-06	Stock, PWK28 With boost holes at top	pair	005-835
YFZ350 Banshee	87-06	PJ34, PWK33 - 35 TM34. With boost holes at top	pair	005-836
YFZ350 Banshee	87-06	PJ34, PWK33 - 35 TM34. No boost holes at top	pair	005-837
YFZ350 Banshee	87-06	PWK38 - 39, TM38 No boost holes at top	pair	005-844
YFM660 Raptor	01-05	Stock, FCR35, FCR39	pair	005-839



Yamaha YFM660 Raptor

## UPP Carb Boots for Yamaha YFZ350 Banshee

For mounting carburetor to stock airbox. Made of polyurethane. Stronger, tougher and more durable than the stock rubber boots. Sold in pairs.

Model	Year	Carb Application	Qt	Order No.
YFZ350 Banshee	87-06	Stock, PWK28	pair	005-845
YFZ350 Banshee	87-06	PJ34, PWK33 - 35, TM34	pair	005-846



Honda CB750

## UPP Intake Manifolds for Vintage Street

### Honda

Model	Mfg. No.	Qt	Order No.
CB750 (SOHC)	VM29/A2HSM	set of 4.	005-026

For mounting aftermarket performance carburetors to CB750 (SOHC) from 1969 to 1978 SOHC models.

### Yamaha

Model	Mfg. No.	Qt	Order No.
XS650 Twin		each	005-815

For mounting aftermarket Mikuni VM carburetors to XS650 2-cylinder models from 1970-1979. 70mm bolt hole center.

RZ350		pair	005-835
-------	--	------	---------

Replacement for OEM Mikuni carburetors on RZ350 from 1984-1985.



## Hose Clamps

Hose Clamp	Size	Order No.
#24 Hose Clamp	38-50/12mm	005-098
#28 Hose Clamp	44-56/12mm	005-092
#40 Hose Clamp	58-75/12mm	005-097
Hose Clamp	TMX/002-32	007-498



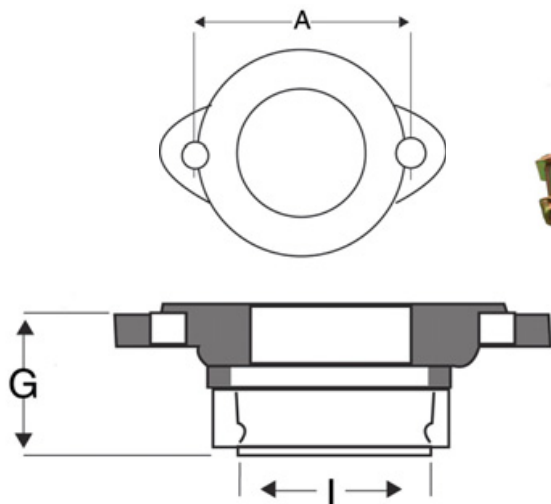

## Mikuni Rubber Mounting Flanges (Diagram and Dimensions)

Sold each. Dimensions listed are millimeters.

8.5mm Bolt Hole Center (A)	Carb Bore Size	Carb Spigot Diameter (I)	Flange Throat Depth (G)	Typical Carb Size Reference No.	Mikuni No.	Order No.	Note
60	30	35	28	26 - 28	M-VM28-200K	<a href="#">002-050</a>	
57	30	37	23	26 - 28	990-842-046	<a href="#">002-051</a>	
75	34	40	32	30 - 34	990-842-007	<a href="#">002-052</a>	
60	36	40	25	30 - 34	M-VM-34-200K	<a href="#">002-053</a>	
70	40	43	25	36 - 40	M-VM-36-200K	<a href="#">002-054</a>	
75	40	43	28	36 - 38	I-VM-38-200-1	<a href="#">002-055</a>	
75	46	52	32	40 - 44	M-VM40-200K	<a href="#">002-056</a>	
84	46	52	26	40 - 44	I-VM44-200-1	<a href="#">002-057</a>	
70-75	40	43	28	36 - 40	KHS-004	<a href="#">002-986</a>	
70-75	42	45	25	42	HS42/018-42K	<a href="#">007-460</a>	
70-75	42	45	25	42	HS42/062-42K	<a href="#">007-468</a>	New Style Oval Port
70-75	45	48	25	45	HS42/018-45K	<a href="#">007-461</a>	
70-75	45	48	25	45	HS42/062-45K	<a href="#">007-469</a>	New Style Oval Port
70-75	48	52	25	48	HS42/062-48K	<a href="#">007-467</a>	New Style Oval Port

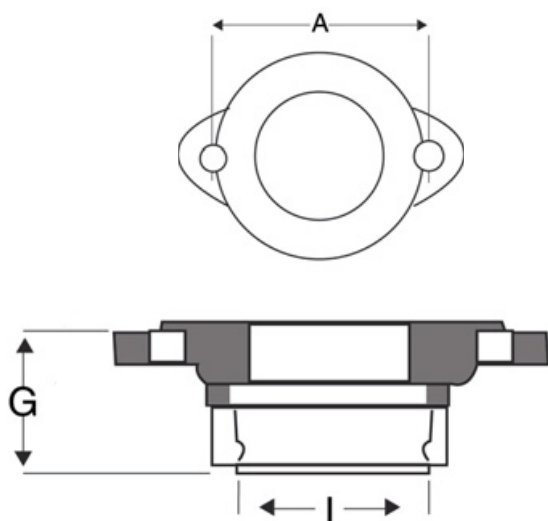

## Amal to Mikuni Rubber Mounting Flanges

Sold each. Dimensions listed are millimeters.

8.5mm Bolt Hole Center (A)	Carb Bore Size	Carb Spigot Diameter (I)	Flange Throat Depth (G)	Flange Throat Diameter	Mikuni Reference	Order No.
50.80 (2")	28	35	24	28	VM26/28	<a href="#">005-800</a>
50.80 (2")	30	40	24	30	VM30	<a href="#">005-801</a>
50.80 (2")	32	40	24	34	VM32	<a href="#">005-802</a>
65	36-38	43	28	37.5	VM36/38	<a href="#">005-810</a>

# Sudco Intake Carb Holders



005-897



005-865

## Sudco Intake Carb Holders

Use with the original OEM carburetors. *Made in Japan* to OEM specifications. Available in kits only. Order per Sudco part number.

**Stock OEM hose clamps must be used when installed.**

**Note:** Some of the applications listed require o-ring or gasket.

LH to RH - From left to right behind engine when installing.

### Honda

#### Carb Holder Kit CB750K0 Order No. 005-897

Includes qt 4 Carb Holders

LH & RH outside only, 16211-300-305 (1 & 4)

LH & RH inside only, 16212-300-305 (2 & 3)

#### Application

CB750K0 69-70

#### Carb Holder Kit CB750K1-5 Order No. 005-898

Includes qt 4 Carb Holders

LH & RH outside only, 16211-300-030 (1 & 4)

LH & RH inside only, 16212-300-030 (2 & 3)

#### Application

CB750K1-K5 71-75

CB750K 1976

CB750F Super Sport 1976

### Kawasaki

#### Carb Holder Kit Z1/KZ900/KZ1000 Order No. 005-865

Includes qt 2 LH Carb Holders and qt 2 RH Carb Holders

LH side only, 16065-029

RH side only, 16065-028

Z1/Z1A/Z1B 900 73-75

KZ900A4 1976

KZ900B1 LTD 1976

KZ1000A1/A2 77-78

KZ1000A3/A4 MKII 79-80

KZ1000B1/B2/B3/B4 LTD 77-80

KZ1000C1-C4 Police 78-81

KZ1000E1/E2 Shaft 79-80

KZ1000D1 Z1R 1978

KZ1000D3 Z1R 1980

#### Carb Holder Kit KZ1000/KZ1100 Order No. 005-866

Includes qt 4 Carb Holders

LH & RH sides 16065-1135

KZ1000J1/J2 81-82

KZ1000K1/K2 LTD 81-82

KZ1000M1/M2 CSR 81-82

KZ1000P1-P21 Police 82-02

KZ1000P24 Police 2005

KZ1000R1 Replica 1982

KZ1100A1/A2 Shaft 81-82

KZ1100B2 GPz 1982

KZ1100D1 Spectre 1982

### Kawasaki

#### Carb Holder Kit KZ1000/1100/ZX1100 Order No. 005-867

Includes qt 4 Carb Holders

LH & RH sides, 16065-1131

KZ1000J3 1983

KZ1000R2 Replica 1983

KZ1100A3 Shaft 1983

KZ1100D2 Spectre 1983

KZ1100L1 LTD 1983

ZN1100B1/B2 LTD 84-85

ZX1100A1/A2 GPz 83-84

#### Carb Holder Kit ZX1000A Order No. 005-870

Includes qt 4 Carb Holders

LH & RH sides, 16065-1130

ZX1000A1/A2 Ninja 1000R 86-87

#### Carb Holder Kit EX500 Order No. 005-871

Includes qt 2 Carb Holders

LH & RH sides, 16065-1130

EX500A1/A2/A3/A4/A5/A6/A7 87-93

EX500D1/D2/D3 Ninja 500 94-96

EX500D4-D12 Ninja 500R 97-05

EX500D6F/D7F/D8F/D9F 06-09

#### Carb Holder Kit ZX600A/B/C Order No. 005-872

Includes qt 4 Carb Holders

LH & RH sides, 16065-1129

ZX600A1/A2/A3 Ninja 600 85-87

ZX600B1 Ninja 600R 1987

ZX600C1-C10 Ninja 600R 88-97

#### Carb Holder Kit ZX900A Order No. 005-873

Includes qt 4 Carb Holders

LH & RH sides, 16065-1108

ZX900A1/A2/A3 Ninja 900R 84-86

#### Carb Holder Kit ZX1000B Order No. 005-874

Includes qt 4 Carb Holders and qt 4 Intake O-Rings

LH & RH sides, 16065-1182

Intake O-Ring, 92055-1401

ZX1000B1/B2/B3 Ninja ZX-10 88-90

#### Carb Holder Kit ZX1100C/D Order No. 005-875

Includes qt 4 Carb Holders and qt 4 Intake O-Rings

LH & RH sides, 16065-1210

Intake O-Ring, 92055-1401

ZX1100C1/C2/C3/C4 Ninja ZX-11 90-93

ZX1100D1-D9 Ninja ZX-11 93-01

#### Carb Holder Kit Order No. 005-876

Includes qt 4 Carb Holders and qt 4 Intake O-Rings

LH & RH sides, 16065-1307

Intake O-Ring, 92055-1401

ZR1100C3/C4 ZRX1100 99-00

ZX1100E1/E2/E3 GPz1100 95-97

ZX1100F1 GPz1100 (ABS) 1997

ZR1200A1/A2/A3/A4/A5 ZRX1200 01-05



005-892



005-880

## Suzuki

### Carb Holder Kit GSF600

Order No. **005-891**

Includes qt 2 LH Carb Holders, 2 RH Carb Holders and qt 4 Intake O-Rings

LH side, 1 & 2, 13101-26E01

RH side, 3 & 4, 13103-26E01

GSF600ST/SV/SW/SX/SY Bandit 96-00

GSF600SSK1/SK2/SK3 Bandit 01-03

### Carb Holder Kit GSX750

Order No. **005-892**

Includes qt 4 Carb Holders and qt 4 Intake O-Rings

LH 1 side, 13101-17C01

LH 2 side, 13102-17C01

RH 3 side, 13103-17C01

RH 4 side, 13104-17C01

GSX750FK/FL/FM/FN/FP Katana 89-93

GSX750FR/FS/FT/FV Katana 94-97

GSX-R750J/K 88-89

### Carb Holder Kit GSX-R750L/M/N

Order No. **005-893**

Includes qt 4 Carb Holders and qt 4 Intake O-Rings

LH 1 side, 13101-17D00

LH 2 side, 13102-17D00

RH 3 side, 13103-17D00

RH 4 side, 13104-17D00

GSX-R750L/M/N (49 state only) 90-92

### Carb Holder Kit GSX1100G/GSF1200

Order No. **005-894**

Includes qt 4 Carb Holders and qt 4 Intake O-Rings

LH 1 side, 13101-40C00

LH 2 side, 13102-40C00

RH 3 side, 13103-40C00

RH 4 side, 13104-40C00

GSX1100GM/GN/GP Shaft 91-93

GSX-R1100K/L/M/N 89-92

GSF1200SV/SW/SX/SY Bandit 97-00

### Carb Holder Kit GSX-R750W

Order No. **005-895**

Includes qt 4 Carb Holders and qt 4 Intake O-Rings

LH side 1 & 2, 13101-17E01

RH side 3, 13103-17E01

RH side 4, 13104-17E01

GSX-R750WP/WR/WS (49 state only) 93-95

## Yamaha

### Carb Holder Kit SR500/TT500/XT500

Order No. **005-880**

Includes qt 1 Carb Holder and qt 1 Intake Gasket

Carb Holder, 583-13565-01-00

Intake Gasket, 583-13556-01-00

SR500E/F/G/H 78-81

TT500C/D/E/F/G/H Offroad 76-81

XT500C/D/E/F/G/H Dual Sport 76-81

## Yamaha

### Carb Holder Kit FZ600

Order No. **005-881**

Includes qt 2 LH Carb Holders, qt 2 RH Carb Holders and

qt 4 Intake Gaskets

LH side, 1 & 2, 33M-13586-01-00

RH side, 3 & 4, 33M-13596-01-00

Intake Gasket, 33M-13556-00-00

FZ600S/SC/T/TC/U/UC 86-88

### Carb Holder Kit YX600

Order No. **005-882**

Includes qt 2 LH Carb Holders, qt 2 RH Carb Holders and

qt 4 Intake Gaskets

LH side 1 & 2, 33M-13586-01-00

RH side, 3 & 4, 33M-13596-01-00

Intake Gasket, 3KM-13556-00-00

YX600S/SC/T/TC/U/UC/W/WC/A/AC Radian 86-90

### Carb Holder Kit YZF750/FZR1000

Order No. **005-883**

Includes qt 2 LH Carb Holders and qt 2 RH Carb Holders

LH side, 1 & 2, 3GM-13597-00-00

RH side, 3 & 4, 3GM-13598-00-00

YZF750RF/RFC 1994

YZF750RH/RHC/RJ/RJC/RK/RKC 96-98

FZR1000W/WC/A/AC/B/BC 89-91

FZR1000D/DC/E/EC/F/FC 92-95

YZF1000R/RJC 1997

### Carb Holder Kit XS1100

Order No. **005-879**

Includes qt 2 LH Carb Holders and qt 2 RH Carb Holders

LH side, 1 & 2, 2H7-13586-00-00

RH side, 3 & 4, 2H7-13596-00-00

XJ1100J Maxim 1982

(intake gasket not available for XJ1100 model)

XS1100E/F/G/H 78-81

XS1100LG/LH Midnight Special 80-81

XS1100SF/SG/SH Special 79-81

### Carb Holder Kit TT/XT600

Order No. **005-884**

Includes qt 1 LH Carb Holder, qt 1 RH Carb

Holder and qt 2 Intake O-Rings

LH side, 43F-13586-01-00

RH side, 43F-13596-01-00

Intake O-Ring, 93210-36549

TT600N Offroad 1985

XT600L/LC/N/NC/S/SC/T/TC/U/UC/W/WC Dual 84-89

### Carb Holder Kit XS650

Order No. **005-878**

Includes qt 1 LH Carb Holder, qt 1 RH Carb Holder

LH Carb Holder, 447-13555-01-00

RH Carb Holder, 447-13565-01-00

TX650A 1974

XS650B/C/D 75-77

# Sudco Intake Carb Holders



005-885



005-950



005-955

## Yamaha

### Carb Holder Kit XT600 Order No. 005-885

Includes qt 1 LH Carb Holder, qt 1 RH Carb Holder  
and qt 2 Intake O-Rings  
LH side, 43F-13586-01-00  
RH side, 1VJ-13596-00-00  
Intake O-Ring, 93210-36549  
XT600EA/EAC/EB/EBC/ED/EDC Dual Sport 90-92  
XT600EE/EEC/EF/EFC/EG/EGC Dual Sport 93-95

### Carb Holder Kit XS650 Order No. 005-877

Includes qt 1 LH Carb Holder and qt 1RH Carb Holder  
LH Carb Holder, 3G1-13586-00-00  
RH Carb Holder, 447-13596-00-00  
XS650G/H Special II 80-81  
XS650SG/SH Special 80-81  
XS650SJ/SK Heritage Special 82-83

### Carb Holder Kit XVS650 Order No. 005-886

Includes qt 1 LH Carb Holder, qt 1 RH Carb Holder and  
qt 2 Intake O-Rings  
LH Carb Holder, 4TR-13586-01-00  
RH Carb Holder, 4TR-13596-01-00  
XVS650AK/AKC-AW/AWC V-Star 650 Classic 98-07  
XV650AWC-B/AW-B V-Star 650 Classic w/flames 2007  
XVS650AX/AXCL/AXCB V-Star 650 Classic 2008  
XVS650AXB/AXCL/AXL V-Star 650 Classic 2008  
XVS650AYCS/AYS/AYCW/AYW V-Star Classic 2009  
XVS650AZCL/AZCR V-Star 650 Classic 2010  
XVS650AZL/AZR V-Star 650 Classic 2010  
XVS650K/KC-S/SC V-Star 650 Custom 98-04  
XVS650TC-F/T-F V-Star 650 Custom w/flames 2005  
XVS650V/VC/W/WC/X/XC V-Star 650 Custom 06-08  
XVS650XCR/XR V-Star 650 Custom 2008  
XVS650YCL/YL/ZCW/ZW V-Star 650 Custom 09-10  
XVS650AB/ACB V-Star 650 Custom 2011  
XVS650T-Z V-Star 650 Midnight Custom 05-10  
XVS650ATR/ATRC-ATCB V-Star 650 Silverado 03-10

### Carb Holder Kit XS750/850 Order No. 005-888

Includes qt 3 Carb Holders  
Carb Holder, 2F3-13586-01-00  
XS750E/F 78-79  
XS750SE/SF Special 78-79  
XS850G/H 80-81  
XS850LG/LH Midnight Special 80-81  
XS850SG/SH Special 80-81

### Carb Holder Kit YZF-R1 Order No. 005-887

Includes qt 2 LH Carb Holders and qt 2 RH Carb Holders  
LH side 1 & 2, 4XV-13598-00-00  
RH side, 3 & 4, 4XV-13597-00-00  
YZF-R1K/KC/L/LC/M/MC/N/N/C 98-01  
YZF-R1SN/SNC Champions Limited Edition 2001

## Carb Holder Clamp

Fits stock carb holder. Dark green color. *Made in Japan.*  
Sold each, and set/4.

## Kawasaki

Carb Holder Clamp, each	Order No. 005-950 (45.56mm I.D.)
Carb Holder Clamp, set/4	Order No. 005-950S
Z1/A/B-900	73-75
KZ900A4/A5	76-77
KZ1000A1/A2	77-78
KZ1000A3/A3A/A4 MKII	79-80
KZ1000B1/B2/B3/B4 LTD	77-78
KZ1000D1 Z1R	1978
KZ1000D3 Z1R	1980
KZ1000E1/E2 Shaft ST	79-80

Carb Holder Clamp, each	Order No. 005-955 (52mm I.D.)
Carb Holder Clamp, set/4	Order No. 005-955S
KZ1000J1/J2/J3	81-83
KZ1000K1/K2 LTD	81-82
KZ1000M1/M2 CSR	81-82
KZ1000P1-P21 Police	82-02
KZ1000P24 Police	2005
KZ1100A1/A2/A3 Shaft	81-83
KZ1100D1/D2 Spectre	82-83
KZ1100L1 Shaft LTD	1983
ZN1100B1/B2 Shaft LTD	84-85
ZX1100A1/A2 GPz	83-84



## Carb Holder Rubber Plugs

Universal rubber plug has many uses. *Made in Japan.* Sold pk/5.

Order No. 005-860



## Sudco Carb Vacuum Fitting Cap

Replacement part for Mikuni RS Smoothbore carburetors.  
This rubber plug is found on many Yamaha models.

*Made in Japan.* Sold each.

Order No. 002-646

# Sudco Intake Carb Holder Dimensions

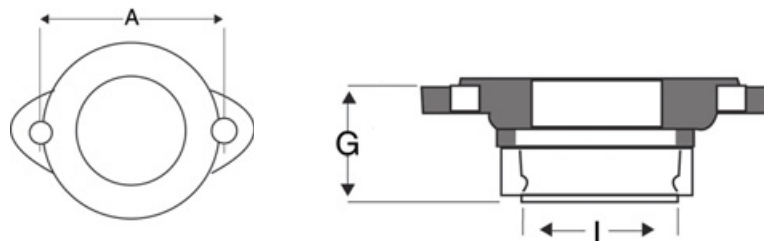

## Kawasaki

Notes	OEM Reference	Bolt (A) Center	Inner (I) Diameter	Length (G)	Offset	Port Y/N
---	16035-1135	58mm	40mm	26mm	N	N
---	16065-028	58mm	32mm	30mm	N	Y
---	16065-029	58mm	32mm	30mm	N	Y
---	16065-1131	58mm	40mm	26mm	N	N
---	16065-1130	N/A	40mm/44mm	40mm	N	N
---	16065-1129	N/A	38mm/38mm	32mm	N	N
---	16065-1108	N/A	42mm/44mm	20mm	N	N
---	16065-1182	60mm	42mm	30mm	N	Y
---	16065-1210	60mm	46mm	46mm	N	N
---	16035-1182	60mm	42mm	30mm	N	N

## Suzuki

---	13101-26E01	68mm	38mm	40mm	Y	N
---	13103-26E01	68mm	38mm	40mm	Y	N
---	13101-17C01	68mm	42mm	36mm	Y	N
---	13102-17C01	68mm	42mm	36mm	N	N
---	13103-17C01	68mm	42mm	36mm	N	N
---	13104-17C01	68mm	42mm	36mm	Y	N
---	13101-17D00	68mm	46mm	38mm	Y	N
---	13102-17D00	68mm	46mm	38mm	N	N
---	13103-17D00	68mm	46mm	38mm	N	N
---	13104-17D00	68mm	46mm	38mm	Y	Y
---	13101-40C00	68mm	42mm	40mm	Y	N
---	13102-40C00	68mm	42mm	40mm	N	N
---	13104-40C00	68mm	42mm	40mm	N	N
Angled	13101-17E01	68mm	46mm	45mm/33mm	N	N
Angled	13103-17E01	68mm	46mm	45mm/33mm	N	Y
Angled	13104-17E01	68mm	46mm	45mm/33mm	N	N

## Yamaha

Slight Offset	2F3-13586-01-00	N/A	---	---	Y	N
Slight Angle	3G1-13586-00-00	70mm	---	---	N	Y
Slight Angle	3G1-13596-00-00	70mm	---	---	N	Y
Slight Angle	447-13555-01-00	70mm	---	---	N	N
Slight Angle	447-13565-01-00	70mm	---	---	N	N
Agressive Offset	2H7-13586-00-00	65mm	---	---	Y	Y
Agressive Offset	2H7-13596-00-00	65mm	---	---	Y	Y
---	583-13565-01-00	70mm	42mm	26mm	N	N
---	33M-13586-01-00	58mm	34mm	30mm	Y	Y
---	33M-13596-01-00	58mm	34mm	30mm	Y	Y
---	3GM-13597-00-00	N/A	44mm/44mm	23mm	N	N
---	3GM-13598-00-00	N/A	44mm/44mm	23mm	N	N
Slight Offset	43F-13586-01-00	65mm	36mm	38mm	Y	Y
Slight Offset	43F-13596-01-00	65mm	36mm	38mm	Y	N
Slight Offset	1VJ-13596-01-00	65mm	36mm	38mm	Y	N
Agressive Offset	4TR-13586-01-00	65mm	32mm	50mm/75mm	Y	N
Agressive Offset	4TR-13596-01-00	65mm	32mm	50mm/75mm	Y	N
---	4XV-13598-00-00	N/A	45mm/45mm	23mm	N	N
---	4XV-13597-00-00	N/A	45mm/45mm	23mm	N	N

# KEIHIN Type Press-Fit Main Jets

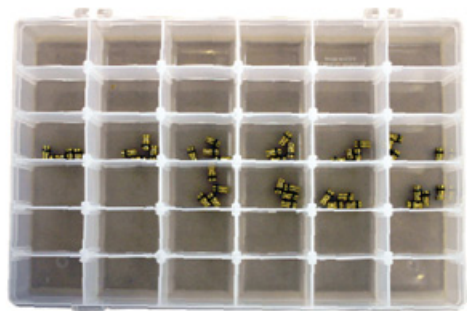

## Sudco Keihin Type Press-Fit Primary Main Jets



KEYSTER brand, aftermarket type jets.  
Dealer kit includes qt 4 jets of sizes listed below.(total 44 jets) with storage box. **Made in Japan.**

**Keihin Type Press-Fit Primary Main Jet Kit Order No. 026-090**  
Includes storage box and qt 4 each of the following size: #60, #62, #65, #68, #70, #72, #75, #82, #88, #90, #92

### Keihin Type Press Fit Primary Main Jets with O-Ring

Sold each.

Size	Order No.	OEM Ref	Size	Order No.	OEM Ref
#60	026-010	99201-601-0600	#75	026-016	99201-601-0750
#62	026-011	99201-601-0620	#82	026-017	99201-601-0820
#65	026-012	99201-601-0650	#88	026-018	99201-601-0880
#68	026-013	99201-601-0680	#90	026-019	99201-601-0900
#70	026-014	99201-601-0700	#92	026-020	99201-601-0920
#72	026-015	99201-601-0720			

## Honda

Model	Year
CB350G Super Sport	1973
CB350K0/K1/K2/K3/K4	68-73
CL350K0/K1/K2/K3/K4/K5	68-73
GL1000K Goldwing	75-79
GL1000L Goldwing LTD	1976

## Sudco Keihin Type Press-Fit Secondary Main Jets



KEYSTER brand, aftermarket type jets.  
Dealer kit includes qt 4 jets of sizes listed below.(total 68 jets) with storage box. **Made in Japan.**

**Keihin Type Press-Fit Secondary Main Jet Kit Order No. 026-091**  
Includes storage box and qt 4 each of the following size: #68, #70, #72, #75, #78, #80, #98, #100, #105, #110, #115, #120, #125, #130, #135, #140, #150

### Keihin Type Press Fit Secondary Main Jets with O-Ring

Sold each.

Size	Order No.	OEM Ref	Size	Order No.	OEM Ref
#68	026-043	99202-601-0680	#110	026-054	99202-601-1100
#70	026-044	99202-601-0700	#115	026-055	99202-601-1150
#72	026-045	99202-601-0720	#120	026-056	99202-601-1200
#75	026-046	99202-601-0750	#125	026-057	99202-601-1250
#78	026-047	99202-601-0780	#130	026-058	99202-601-1300
#80	026-048	99202-601-0800	#135	026-059	99202-601-1350
#98	026-051	99202-601-0980	#140	026-060	99202-601-1400
#100	026-052	99202-601-1000	#150	026-062	99202-601-1500
#105	026-053	99202-601-1050			

## Honda

Model	Year
CB350F/F1 Super Sport	72-74
CB350G Super Sport	1973
CB350K0/K1/K2/K3/K4	68-73
CL350K0/K1/K2/K3/K4/K5	68-73
CB400F Super Sport	75-77
CB500K0/K1/K2	71-73
CB550F Super Sport	75-77
CB550K0/K1	74-75
CB550K	1976
GL1000K Goldwing	75-79
GL1000L Goldwing LTD	1976

## Kawasaki

KZ400A1 Deluxe	1977
KZ400/D/D3/D4	74-77
KZ400S/S2/S3 Special	75-77

## Yamaha

TX500/A	73-74
XS500B	1975

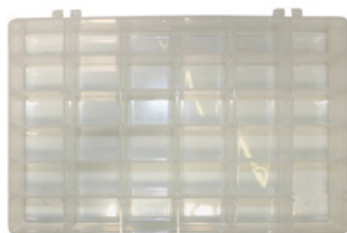

008-001



008-002

## Sudco Plastic Jet Boxes (Storage Boxes)

Two boxes available, 36 compartment and 18 compartment.  
Use for valve shim storage, small parts, electrical connectors and carburetor jets. Sold each.

Description	Order No.
Jet Box with 36 Compartments 7-1/2" L x 10-1/2" L x 1-1/4" H	008-001
Jet Box with 18 Compartments 3-1/4" L x 6-3/4" L x 1-1/2" H	008-002



## Sudco Hitachi Type Main & Pilot Jets

KEYSTER brand, aftermarket screw-in type jets for Yamaha applications. Dealer kit includes qt 4 jets of sizes listed below. (total 56 jets) with storage box. **Made in Japan.**

**Hitachi Type Main & Pilot Jet Kit** Order No. **026-190**

Includes storage box and qt 4 each size of the following:

Main Jets: #110, #112, #116, #118, #120, #122, #124, #126, #128, #130, #132, #134, Pilot Jets: #40, #41

**Hitachi Type Main Jets** Sold each.

Size	OEM Reference	Order No.
#110	4H7-14925-10-00	<b>026-110</b>
#112	4H7-14925-12-00	<b>026-111</b>
#116	4H7-14925-16-00	<b>026-113</b>
#118	4H7-14925-18-00	<b>026-114</b>
#120	4H7-14925-20-00	<b>026-115</b>
#122	4H7-14925-22-00	<b>026-116</b>
#124	4H7-14925-24-00	<b>026-117</b>
#126	4H7-14925-26-00	<b>026-118</b>
#128	4H7-14925-28-00	<b>026-119</b>
#130	4H7-14925-30-00	<b>026-120</b>
#132	4H7-14925-32-00	<b>026-121</b>
#134	4H7-14925-34-00	<b>026-122</b>

**Hitachi Type Pilot Jets** Sold each.

Size	OEM Reference	Order No.
#40	4H7-14948-40-00	<b>026-145</b>
#41	4H7-14948-41-00	<b>026-146</b>

## Yamaha

Model	Year
XJ650G/H/J/K Maxim	80-83
XJ650LH Midnight Maxim	1981
XJ650RJ Seca	1982
XJ700N/NC/S/SC Maxim	85-86
XJ750RH/RJ/RK Seca	81-83
XV700L/LC/N/NC Virago	84-85
XV700CS/CSC/CT/CTC Virago	86-87
XV700SS/SSC Virago	1986
XJ750J/K Maxim	82-83
XJ750MK Midnight Maxim	1983
XV750H/J/K Virago	81-83
XV750MK Midnight Virago	1983
XV920J/K Virago	82-83
XV920MK Midnight Virago	1983
XV920RH/RJ Euro	81-82
XV1000L/LC/N/NC	84-85
XV1100S/SC/T/TC Virago	86-87



## Sudco Hitachi Type Needle Valve Assemblies

KEYSTER brand, aftermarket type needle valve assemblies for Yamaha applications. Sold each. **Made in Japan.**

Application	OEM Reference	Order No.
XS850 (80-81)	3J3-W1496-20-00	<b>026-300</b>
XJ650/XJ750/XV750/XV920	10L-14390-02-00	<b>026-302</b>
see 10L-14390-02-00	42H-14390-00-00	<b>026-302</b>



## Sudco Hitachi Float Bowl Gaskets

Aftermarket type for Yamaha applications. Sold each. **Made in Japan.**

Application	OEM Reference	Order No.
XJ650/XJ750 (80-83)	4H7-14984-01-00	<b>026-320</b>
XV750 (81-83),XV920 (1982)	4X7-14984-01-00	<b>026-322</b>
XV1000 (84-85)	10L-14984-01-00	<b>026-324</b>
XS850 (80-81)	3J3-14984-00-00	<b>026-326</b>

## Yamaha

Model	Year	Needle Valve	Float Bowl Gasket
XJ650G/H/J/K Maxim	80-83	<b>026-302</b>	<b>026-320</b>
XJ650LH Midnight Maxim	1981	<b>026-302</b>	<b>026-320</b>
XJ650RJ Seca	1982	<b>026-302</b>	<b>026-320</b>
XJ700N/NC Maxim	1985	<b>026-302</b>	<b>026-320</b>
XJ700S/SC Maxim	1986	<b>026-302</b>	<b>026-320</b>
XJ750J/K Maxim	82-83	<b>026-302</b>	<b>026-320</b>
XJ750MK Midnight Maxim	1983	<b>026-302</b>	<b>026-320</b>
XJ750RH/RJ/RK Seca	81-83	<b>026-302</b>	<b>026-320</b>
XV750H/J/K Virago	81-83	<b>026-302</b>	<b>026-322</b>
XV750MK Midnight Virago	1983	<b>026-302</b>	<b>026-322</b>
XS850G/H	80-81	<b>026-300</b>	<b>026-326</b>
XS850LG/LH Midnight Special	80-81	<b>026-300</b>	<b>026-326</b>
XS850SG/SH Special	80-81	<b>026-300</b>	<b>026-326</b>
XV920J Virago	1982	<b>026-302</b>	<b>026-322</b>
XV920K Virago	1983	<b>026-302</b>	<b>026-324</b>
XV920MK Midnight Virago	1983	<b>026-302</b>	<b>026-324</b>
XV920RH/RJ	81-82	<b>026-302</b>	<b>026-322</b>
XV1000L/LC/N/NC Virago	84-85	<b>026-302</b>	<b>026-324</b>
XV1100S/SC/T/TC Virago	86-87	<b>026-302</b>	<b>026-324</b>

# Sudco Carburetor Hardware & O-Rings

VINTAGE  
INTAKE  
ENGINE  
SUSPENSION  
CONTROL  
ELECTRICAL  
CHEMICAL  
TOOLS  
WATERCRAFT



## Sudco Mikuni Carburetor O-Rings

Genuine OEM MIKUNI carburetor o-rings. *Made in Japan.*

### Order No. 007-945

Sudco Mikuni Carburetor Dealer O-Ring Kit  
Kit includes qt 5 each part number listed below.  
(total qt 75 o-rings and plastic storage box)

O-Ring Description	Size Inside (mm) Inside x Thickness	Mikuni Reference	Order No.
	3.55 I.D. x 1.78mm	BV32/04	<b>002-212</b>
Drain Plug	19.50 I.D. x 1.52mm	VM/28/254	<b>002-531</b>
	17.50 I.D. x 1.52mm	BNO42/64	<b>002-602</b>
	8.70 I.D. x 1.95mm	BV30/40	<b>002-617</b>
Starter Plunger	8.50 I.D. x 1.55mm	VM18/249	<b>002-672</b>
Pilot Air Screw	2.50 I.D. x 1.55mm	VM14/75	<b>002-676</b>
Fuel Joint & Needle Vlv.	7.5 I.D. x 1.53mm	KV/10	<b>002-709</b>
	19.60 I.D. x 2.43mm	VM26/227	<b>002-825</b>
Needle Valve	6.70 I.D. x 1.35mm	VM24/559	<b>002-838</b>
Pilot Air Screw	2.70 I.D. x 1.13mm	N133.037	<b>002-858</b>
Starter/Choke	10.25 I.D. x 1.35mm	N138.198	<b>007-160</b>
	1.80 I.D. x 1.15mm	N124.063	<b>007-163</b>
Fuel Joint	6.25 I.D. x 1.83mm	616-23002	<b>007-182</b>
	3.05 I.D. x 1.35mm	B30/205	<b>007-188</b>
Needle Valve	8.47 I.D. x 1.53mm	616-33003	<b>007-470</b>

## Sudco Keihin Carburetor O-Rings

Genuine OEM KEIHIN carburetor o-rings. *Made in Japan.*

### Order No. 018-905

Sudco Keihin Carburetor Dealer O-Ring Kit.  
Kit includes qt 5 of each part number listed below.  
(total qt 65 o-rings and plastic storage box)

O-Ring Description	Size (mm) Inside x Thickness	Keihin Reference	Order No.
	18.50 I.D. x 2.85mm	16173-001-0040	<b>018-664</b>
	7.90 I.D. x 1.40mm	16075-MB0-0030	<b>018-694</b>
	2.65 I.D. x 1.90mm	0901-006-6000	<b>018-722</b>
Fuel T-Joint	5.65 I.D. x 1.33mm	W9351-13057	<b>018-755</b>
Pilot Screw	2.70 I.D. x 1.20mm	16075-KG8-9010	<b>021-043</b>
M1 Needle Seat	9.10 I.D. x 1.30mm	16958-397-7710	<b>021-047</b>
U-Ring.	3.55 I.D. x 1.95mm	W9353-36000	<b>021-067</b>
Accelerator Pump	4.0 I.D. x 1.05mm	W9353-11042	<b>021-070</b>
	5.80 I.D. x 1.90mm	16178-548-0040	<b>021-071</b>
U-Ring.	6.35 I.D. x 2.95mm	W9353-6500	<b>021-097</b>
Drain Bolt	15.15 I.D. x 1.95mm	16075-935-0060	<b>021-109</b>
Choke O-Ring	8.95 I.D. x 1.35mm	0901-069-6000	<b>021-527</b>
	11.75 I.D. x 1.94mm	16978-ZB9-0050	<b>021-732</b>

## Sudco Carburetor Screws

Genuine carburetor screws in different sizes.  
Use for float bowl, top cover. Sold each.

*Made in Japan.*

CW2 = with lock washer C2 = screw only



Application	Size	Mfg. No.	Order No.
Cable Holder Screw	2.6 x 8mm	CW2=2608	<b>007-265</b>
Needle Valve Holder Screw	3 x 6.5mm	VM13/216	<b>007-174</b>
	3 x 8mm	CW2=0308	<b>002-479</b>
Throttle Valve Screw	3 x 10mm	CW2=0310	<b>002-752</b>
Top Cover Screw	4 x 8mm	CW2=0408	<b>007-175</b>
Top Cover Screw TM33	4 x 10mm	CW2=410	<b>007-626</b>
Top Cover Screw HSR42	4 x 10mm	C5-0410B	<b>007-624</b>
Torx Screw	4 x 12mm	VM38/133	<b>002-749</b>
Float Bowl Screw	4 x 12mm	CW2=0412	<b>002-748</b>
Float Bowl Screw	4 x 12mm	C2=0412-B	<b>007-201</b>
Float Bowl Screw	4 x 14mm	CW2=0414	<b>002-522</b>
Float Bowl Screw short TM33	4 x 14mm	C2=0414	<b>007-621</b>
Float Bowl Screw long TM33	4 x 16mm	C2=0416	<b>007-622</b>
Float Bowl Screw	4 x 16mm	CW2=0416	<b>002-823</b>
Float Bowl Screw	4 x 16mm	CW2=0416-B	<b>002-615</b>
Float Bowl Screw	5 x 14mm	C2=0514-B	<b>007-698</b>
Float Bowl Screw	5 x 14mm	CW2=0514	<b>002-516</b>
Float Bowl Screw	5 x 16mm	CW2=0516	<b>002-373</b>
Float Bowl Screw	5 x 18mm	CW2=0518	<b>002-719</b>



008-001

008-002

## Sudco Plastic Jet Boxes (Storage Boxes)

Two boxes available, 36 compartment and 18 compartment.  
Use for valve shim storage, small parts, electrical connectors and carburetor jets. Sold each.

Description	Order No.
Jet Box with 36 Compartments 7-1/2" L x 10-1/2" L x 1-1/4" H	<b>008-001</b>
Jet Box with 18 Compartments 3-1/4" L x 6-3/4" L x 1-1/2" H	<b>008-002</b>





040-60005



040-60033

## Nitrous Express Systems

Whether you want just a little help with your Sportbike, Street or Drag Racer, Bonneville rocket, ATV, Snowmobile or watercraft, Nitrous Express is the system Pro's use. Complete kits available.

### ATV, Offroad, Snowmobile & Personal Watercraft

Description	Order No.
1 Cylinder Piranha Nozzle 2.5 lb./2 ft. with out Fuel Pump	040-60001
1 Cylinder Piranha Nozzle 2.5 lb./2 ft. with Fuel Pump	040-60011
2 Cylinder Twin Piranha Nozzle 2.5 lb./2 ft. with Fuel Pump	040-60002
3 Cylinder Piranha Nozzle 2.5 lb./2 ft. with Fuel Pump	040-60033
4 Cylinder Piranha Nozzle 2.5 lb./2 ft. with Fuel Pump	040-60005
4 Cylinder Pro Modified/Funny Bike Piranha Nozzle 2.5 lb./2 ft. with Fuel Pump	040-60006

### Motorcycles & Sportbikes

Description	Order No.
2 Cylinder Twin Piranha Nozzles 2.5 lb./2 ft. w/Fuel Pump	040-60002
3 Cylinder Piranha Nozzles 2.5 lb./2 ft. with Fuel Pump	040-60033
4 Cylinder Piranha Nozzles 2.5 lb./2 ft. with Fuel Pump	040-60005
4 Cylinder Pro Modified/Funny Bike Piranha Nozzle 2.5 lb./2 ft. with Fuel Pump	040-60006
4 Cylinder Piranha conversion with Stainless Steel Braided Lines and Shower Heads	040-NX400S
Suzuki Hayabusa 2.5 lb./2 ft. with Fuel Pump	040-60007

### Harley-Davidson® & Cruisers

Description	Order No.
H-D® Stage One Piranha Nozzle 2.5 lb./2 ft. w/Fuel Pump	040-60022
H-D® Show Polished Dual Bottles & Billet Brackets	040-60122
2.-1.4 lb./2 ft. w/Fuel Pump	
H-D® Show Polished Dual Bottles & Billet Brackets	040-60123
2.-10 oz./2 ft. w/Fuel Pump	



## Nitrous Express Nitrous Bottles

Highest flowing bottle valve on the market.

Available in the following sizes:

### Nitrous Bottles

Description	Order No.
16 oz. Bottle with Motorcycle Valve	040-11010
10 oz. Bottle with Motorcycle Valve	040-11022
1.4 lb. Bottle with Motorcycle Valve	040-11023
1.4 lb. Bottle with Motorcycle Valve (show polished)	040-11024
2.5 lb. Bottle with Motorcycle Valve	040-11025
2.0 lb. Bottle with Motorcycle Valve	040-11030
5.0 lb. Bottle with Motorcycle Valve	040-11055

*Call sales department to order jets, replacement parts and accessories.*



# Carb Pump Diaphragm Valve Sets



007-783



007-782



007-785



007-781

## Carb Pump Diaphragm Valve Sets

Each set contains one diaphragm with rod attached, one rubber boot for rod, spring and o-ring as required. Sold as a set, three or four piece as noted. **Made in Japan.**

### Honda

**OEM Reference** 16021-ME2-771 (4 pc. set) **Order No. 007-783**  
1602-MG1-671 - Diaphragm with 55.60mm long rod, spring, rubber boot for rod, and o-ring for passageway.

Model	Year
CX650C	1983
GL650	1983
GL650I	1983
CB1000C	1983
CB1100F Super Sport	1983

**OEM Reference** 16021-679-005 (3 pc. set) **Order No. 007-782**  
Diaphragm with 54.01mm long rod, spring, rubber boot for rod.

Model	Year
CB750C Custom	80-82
CB750F Super Sport	79-82
CB750K	79-82
CB750L LTD	1979
CB750SC Nighthawk 750	82-83
CB900C Custom	80-82

**OEM Reference** 16021-MW8-000 (3 pc. set) **Order No. 007-785**

16021-MN5-0074, 16021-MT8-000, 16021-MAM-A80  
Diaphragm with 31.31mm long rod, spring, rubber boot for rod.

Model	Year
GL1500 Goldwing	88-90
GL1500A Goldwing Aspencade	91-00
GL1500I Goldwing Interstate	91-96
GL1500SE Goldwing SE	90-00



007-784

**OEM Reference** 16021-422-004 (3 pc. set) **Order No. 007-784**  
Diaphragm with 50.88mm long rod, spring, rubber boot for rod.

Model	Year
CBX1000 (1047cc) Super Sport	79-82

### Honda

**OEM Reference** 16021-413-751 (4 pc. set) **Order No. 007-781**  
16021-438-671, 16021-463-004 - Diaphragm with 54.13mm long rod, spring, rubber boot for rod.

Model	Year
CM250C Custom	1983
CB400T Hawk	80-81
CM400A Automatic	80-81
CM400C Custom	1981
CM400E	80-81
CM400T	80-81
CB450SC Nighthawk	1982
CB450T Hawk	1982
CM450C Custom	1982
CM450E	1982
CX500C Custom	80-82
CX500D Deluxe	80-81
GL500 Silverwing	81-82
GL500I Silverwing Interstate	81-82
CB900F Super Sport	81-82
GL1100 Goldwing	80-83
GL1100A Goldwing Aspencade	82-83
GL1100I Goldwing Interstate	80-83



007-780

**OEM Reference** 16021-MC9-771 (3 pc. set) **Order No. 007-780**

16021-393-004, 16021-393-014 - Diaphragm with 89.46mm long rod, spring, rubber boot for rod.

Model	Year
CB450SC Nighthawk	1983
CB450SC Nighthawk	85-86
CM450E	1983
CB750A Automatic	76-78
CB750F Super Sport	77-78
CB750K	77-78



## Sudco Mikuni Carb Slide Diaphragms

GENUINE Mikuni Carb Slide Diaphragms for models listed. Fits OEM carburetors. **Made in Japan.** Sold each.

### Suzuki

Carb Slide Diaphragm 13507-17C01, 13507-17C00  
Diaphragm rubber only, no slide body

Order No. **007-776**

Model	Year
DR-Z400EK4-EK7 (California models, E33)	04-07
DR-Z400K4/K5/K6 Offroad (California models, E33)	04-06
DR-Z400SY/SK1-SK9 Dual Sport	00-09
DR-Z400SL1/SL2 Dual Sport	11-12
DR-Z400SMK5/SMK6/SMK7/SMK8/SMK9 Supermotard	05-09
GS500EK-EK2	89-02
GS500FK4/FK5/FK6/FK7/FK8/FK9	04-09
GS500HK7/HK8/HK9 (naked)	07-09
GSX600FJ-FV Katana	88-97
GSX-R600WN/WP	92-93
GSX-R600V/W/X/Y	97-00
RF600RR/RS/RT	94-96
GSX750FK-FK2 Katana	89-02
GSX750FK3/FK4/FK5/FK6	03-06
GSX-R750J/K/L/M/N (California model)	89-92
GSX-R750WP/WR/WS (California model)	93-95
GSX-R750T/V	96-97
RF900RR/RS/RZS/RT/RV	94-97
GSX1100GM/GN/GP Shaft	91-93
GSX-R1100K/L/M/N	89-92
GSX-R1100WP/WR/WS/WT/WV/WV	93-98
GSF1200SV/SAV/SW/SX/SY/SK1/SK2 Bandit	97-02
GSF1200SK3/SK4/SK5/SK6 Bandit	03-06
VL1500W/X/Y Intruder LC	98-00
VL1500K1/K2/K3/K4 Intruder LC	01-04

### Yamaha

Carb Slide Diaphragm 41R-14940-09-00

Order No. **007-775**

Model	Year
XV535A/AC Virago	1990
XV535E/EC/F/FC/G/GC Virago	93-95
XV535H/HC/J/JC Virago	96-97
XV535SF/SFC/SG/SGC Virago	94-95
XV535SH/SHC/SJ/SJC/SK/SKC Virago	96-98
XV535L/LC/M/MC Virago 535	99-00
XVZ12TK/L/KC2 Venture	83-84
XVZ12TDK Venture Royale	1983
XVZ12DN Venture Royale	1985

### Yamaha

Carb Slide Diaphragm 2F3-14940-00-00, 2A2-14940-00-00

Order No. **007-770**

Model	Year
XS400D/E/2E/F/2F	77-79
XS750E/F	78-79
XS750SE/SF Special	78-79
XS1100E/F	78-79
XS1100SF Special	1979

Carb Slide Diaphragm 1FK-14940-09-00

Order No. **007-771**

VMX12N/NC/S/SC V-Max	85-86
VMX12U/UC/W/WC/A/AC/B/BC V-Max	88-91
VMX12D/DC/E/EC/F/FC/G/GC V-Max	92-95
VMX12H/HC/J/JC/K/KC/L/LC V-Max	95-99
VMX12M/MC/N/NC/P/PC/R/S/SC V-Max	00-04
VMX12T/TC/V/VC/W1/W1C V-Max	05-07
XVZ13T/TC/U/UC Venture	87-88
XVZ13DS/DSC/DT/DTC Venture Royale	86-87
XVZ13DU/DUC/DW/DWC Venture Royale	88-89
XVZ13DA/DAC/DB/DBC Venture Royale	90-91
XVZ13DD/DDC/DE/DEC Venture Royale	92-93

Carb Slide Diaphragm 3F7-14940-00-00, 3H5-14940-00-00

Order No. **007-772**

SR250G/H/J Exciter	80-82
SR250TH Exciter	1981
XS650G/H Special II	80-81
XS650SG/SH Special	80-81
XS650SJ/SK Heritage Special	82-83
XJ900RK Seca	1983
XJ1100J Maxim	1982
XS1100G/H	80-81
XS1100LG/LH Midnight Special	80-81
XS1100SG/SH Special	80-81

Carb Slide Diaphragm 50H-14940-00-00,

Order No. **007-773**

FJ1100L/LC/N/NC	84-85
FJ1200S/SC/T/TC	86-87
FJ1200W/WC/A/AC/B/BC/D/DC	89-92
FJ1200AD/ADC/AE/AEC (ABS)	92-93

Carb Slide Diaphragm 256-14940-00-00, 256-14940-01-00

Order No. **007-774**

XS500C/D	76-77
XS1/XS1-B/XS2-650	70-72
TX650/A	73-74
XS650B/C/D	75-77

# KEIHIN & MIKUNI Accelerator Pump Rebuild Kits

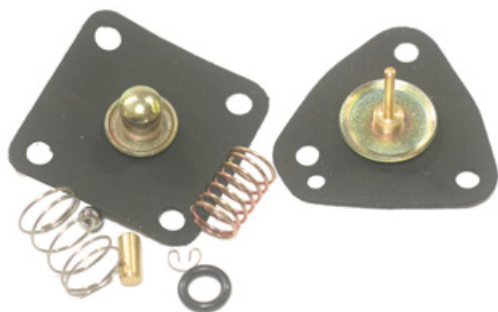

## Accelerator Pump Rebuild Kit for Kawasaki KZ650/KZ1000

Eight piece kit fits Kawasaki Vintage models listed from 1979-1981. *Made in Japan.*

Order No. **018-863**

### Kawasaki OEM Mikuni VM Carburetor

Qt	OEM Reference	Description
Qt.1	43028-1112	Carb Pump Diaphragm (square )
Qt.1	43028-1010	Carb Pump Sensor Diaphragm (triangular)
Qt.1	92081-1137	Carb Pump Sensor Diaphragm Spring
Qt.1	92081-1139	Carb Pump Diaphragm Spring
Qt.1	16038-016	Check Valve O-ring
Qt.1	92037-1123	Check Valve Clamp Spring (clip)
Qt.1	13042-1004	Check Valve Weight
Qt.1	92140-1003	Check Valve Ball (steel)

Applications, Kawasaki OEM Mikuni VM only	Year
KZ650B3/C3/D2	1979
KZ650E1 LTD	1980
KZ650F1	1980
KZ650H1 CSR	1981
KZ1000A3/A3A/A4 MKII	79-80
KZ1000B3/B4 LTD	79-80
KZ1000C2/C3/C4 Police	79-81
KZ1000D3 Z1R	1980
KZ1000E1/E2 Shaft ST	79-80



## Factory R&D P-38 Lightning Accelerator Pump Cover

Factory R&D P-38 Lightning is a high-performance, bolt-on accelerator cover plate that cures that annoying hesitation and stumbling while adding horsepower and throttle response. Sold each.

### Honda

Model	Carburetor	Year	Factory R&D No.	Order No.
CRF250R/X	FCR-MX	04-07	P-38#4	<b>024-006</b>
CRF450R	FCR-MX	02-03	P-38#3	<b>024-005</b>
CRF450R	FCR-MX	2004	P-38#9	<b>024-011</b>
CRF450R	FCR-MX	05-06	P-38#10	<b>024-012</b>
CRF450R	FCR-MX	2007	P-38#4	<b>024-006</b>
CRF450X	FCR-MX	2004	P-38#9	<b>024-011</b>
CRF450X	FCR-MX	05-06	P-38#10	<b>024-012</b>
CRF450X	FCR-MX	2007	P-38#4	<b>024-006</b>
TRX450R ATV	FCR-MX	2006	P-38#9	<b>024-011</b>



## Sudco Accelerator Pump Rebuild Kit for Kawasaki Cruisers

Five piece kit fits Kawasaki Vulcan Cruiser models listed. *Made in Japan.*

Order No. **018-864**

### Kawasaki OEM Keihin CVK Carburetor

Qt	OEM Reference	Description
Qt1	43028-0002	Diaphragm
Qt1	92081-1092	Spring
Qt1	92093-1046	O-Ring ("U" Ring)
Qt2	223D0410	Pan Head Screw 4 x 10mm

Applications: Kawasaki OEM Keihin CVK only	Year
EJ650A2/A3 W650	00-01
VN800A1/A2/A3/A4/A5/A6 Vulcan 800	95-00
VN800A7/A8/A9/A10/A11 Vulcan 800	01-05
VN800B1/B2/B3/B4/B5 Vulcan 800 Classic	96-00
VN800B6/B7/B8/B9 Vulcan 800 Classic	01-04
VN800C1/C2 Vulcan 800 Drifter	99-00
VN800E1/E2/E3/E4/E5 Vulcan 800 Drifter	01-05
VN800E6F Vulcan 800 Drifter	2006
VN1500D1/D2 Vulcan 1500 Classic	96-97
VN1500E1/E2/E3 Vulcan 1500 Classic	98-00
VN1500E4/E5 Vulcan 1500 Classic	01-02
VN1500E6/E7 Vulcan 1500 Classic	03-04
VN1500G1/G1A/G1AL/G1L Vulcan 1500 Nomad	1999
VN1500G2A/G2AL Vulcan 1500 Nomad	2000
VN1500G3/G3L Vulcan 1500 Nomad	2001

### Kawasaki

KX250F	FCR-MX	04-05	P-38#7	<b>024-009</b>
KX250F/KX450F	FCR-MX	06-07	P-38#8	<b>024-010</b>

### KTM

250/400	FCR-H	00-04	P-38#167	<b>024-014</b>
250 F	FCR-MX	03-04	P-38#167	<b>024-014</b>
520	FCR-H	00-02	P-38#167	<b>024-014</b>
525	FCR-MX	03-06	P-38#7	<b>024-009</b>

### Suzuki

RM-Z250F	FCR-MX	04-06	P-38#7	<b>024-009</b>
RM-Z450F	FCR-MX	05-07	P-38#9	<b>024-011</b>

### Yamaha

WR250F	FCR-MX	03-07	P-38#9	<b>024-011</b>
YZ250F	FCR-MX	01-02	P-38#3	<b>024-005</b>
YZ250F	FCR-MX	03-07	P-38#9	<b>024-011</b>
YZ426F	FCR-MX	01-02	P-38#3	<b>024-005</b>
WR450F	FCR-MX	03-06	P-38#9	<b>024-011</b>
WR450F	FCR-MX	2007	P-38#6	<b>024-008</b>
YZ450F	FCR-MX	03-06	P-38#9	<b>024-011</b>
YZ450F	FCR-MX	2007	P-38#6	<b>024-008</b>



018-860



018-861

## Sudco Accelerator Pump Rebuild Kits for Keihin FCR Carburetors

Genuine "KEIHIN" replacement parts. Kits include diaphragm, spring, "u-ring," o-ring, and 4 x 8mm screws. Kits available for Keihin FCR Downdraft & Horizontal carburetors, and Keihin FCR-MX carburetors. **Made in Japan.**

### Keihin FCR Downdraft & Horizontal Carb all

Order No. **018-860**

Accelerator Pump Rebuild Kit - 8 piece Kit

Qt	OEM Reference	Description
Qt1	1201-858-2400	Diaphragm
Qt1	1300-142-2000	Spring
Qt1	W9353-36000	U Ring
Qt1	W9351-19058	O-Ring
Qt1	1458-858-201	Rubber Cap
Qt3	0136-808-1100	4 x 8mm Allen Screw

### Keihin FCR - MX Carb 37, 39, 41mm all

Order No. **018-861**

Accelerator Pump Rebuild Kit - 8 piece Kit

Qt	OEM Reference	Description
Qt1	1201-858-2700	Diaphragm
Qt1	1300-142-2000	Spring
Qt1	W9353-36000	U Ring
Qt1	W9351-19058	O-Ring
Qt1	1458-858-201	Rod
Qt3	0136-808-1100	4 x 8mm Allen Screw

### Keihin FCR - MX Carb Honda 16020-KRN-671

Order No. **018-862**

Accelerator Pump Rebuild Kit - 8 piece Kit

Qt	OEM Reference	Description
Qt1	1201-858-2700	Diaphragm
Qt1	1300-142-2000	Spring
Qt1	W9353-36000	U Ring
Qt1	W9351-19058	O-Ring
Qt1	1458-858-201	Rod
Qt3	CW2=0408	4 x 8mm Screw

Model	Year
CRF250R	2004
CRF250X	04-06
CRF450R	2002

### Keihin FCR-MX Carb Suzuki 13480-35G00

Order No. **018-862**

Accelerator Pump Rebuild Kit - 8 piece Kit

Qt	OEM Reference	Description
Qt1	1201-858-2700	Diaphragm
Qt1	1300-142-2000	Spring
Qt1	W9353-36000	U Ring
Qt1	W9351-19058	O-Ring
Qt1	1458-858-201	Rod
Qt3	CW2=0408	4 x 8mm Screw

Model	Year
RM-Z450K5/K6/K7	05-07

### Keihin FCR - MX Carb Yamaha 5JG-14940-17-00

Order No. **018-862**

Accelerator Pump Rebuild Kit - 8 piece Kit

Qt	OEM Reference	Description
Qt1	1201-858-2700	Diaphragm
Qt1	1300-142-2000	Spring
Qt1	W9353-36000	U Ring
Qt1	W9351-19058	O-Ring
Qt1	5JG-14379-00-00	Starter Rod
Qt3	CW2=0408	4 x 8mm Screw

Model	Year
ATV	
YFZ450BB Bill Balance Edition	06-07
YFZ450LES Limited Edition	2004
YFZ450S/T/V/W	04-07
YFZ450SET/SPV Special Edition	05-06

Offroad	Year
YZ426FN/FP	01-02
YZ450FR	2003
YZ450FSPV 50TH Anniversary	2006
YZ450FT/FV/FW/FX/FXLFXW	05-08
YZ450FYL/FYW	2009

# KEIHIN & MIKUNI Air Cut-Off Valves Sets



010-102

010-103

010-104

010-105

010-114

## Air Cut-Off Valve Sets **NEW**

Direct OE style replacement carburetor air cut off valve set. Includes; diaphragm, spring and o-ring. Located on the side of the carburetor, the air cut off valve prevents lean fuel mixture (backfire) when decelerating. Temporarily closes the pilot jet airway to provide a richer mix as the throttle closes. Sold in sets for one carburetor.

### Honda Street

Model	Year	OEM Reference Air Cut-Off Valve	Order Number
XL250R Dual Sport	82-83	16048-KB7-90	010-105
XL250S Dual Sport	78-79	16048-413-004	010-103
XL250S Dual Sport	80-81	16048-443-901	010-104
VTR250 Interceptor	1988	16048-MM5-671	010-119
VTR250 Interceptor	89-90	16048-MR7-004	010-119
CB400A Automatic	1978	16048-413-004	010-103
CB400T	80-81	16048-443-901	010-104
CB400T1 Hawk	78-79	16048-413-004	010-103
CB400TII Hawk	1979	16048-413-004	010-103
CM400A Automatic	1979	16048-413-004	010-103
CM400A Automatic	80-81	16048-443-901	010-104
CM400C Custom	1981	16048-443-901	010-104
CM400E	80-81	16048-443-901	010-104
CM400T	1979	16048-413-004	010-103
CM400T	80-81	16048-443-901	010-104
CB450SC Nighthawk	82-83	16048-443-901	010-104
CB450SC Nighthawk	1985	16048-443-901	010-104
CB450T Hawk	1982	16048-443-901	010-104
CM450A Automatic	82-83	16048-443-901	010-104
CM450C Custom	1982	16048-443-901	010-104
CM450E	82-83	16048-443-901	010-104
CX500	78-79	16048-413-004	010-103
CX500C Custom	1979	16048-413-004	010-103
CX500C Custom	80-82	16048-443-901	010-104
CX500D Deluxe	1979	16048-413-004	010-103
CX500D Deluxe	80-81	16048-443-901	010-104
FT500 Ascot Single	82-83	16048-KB7-901	010-105
GL500 Silverwing	81-82	16048-443-901	010-104
GL500I Silverwing Interstate	81-82	16048-443-901	010-104
XL500R Dual Sport	1982	16048-KB7-901	010-105
XL500S Dual Sport	78-79	16048-443-901	010-104
CBR600F Hurricane (CA Only)	87-89	16048-MM5-671	010-119
VT600C Shadow VLX	89-97	16048-MR1-305	010-115
VT600C Shadow VLX Deluxe	93-98	16048-MR1-305	010-115
CB650	1979	16048-428-305	010-102
CB650	1980	16048-443-901	010-104
CB650C Custom	1980	16048-443-901	010-104
CX650C Custom	1983	16048-KB7-901	010-105
GL650 Silverwing	1983	16048-KB7-901	010-105
GL650I Silverwing Interstate	1983	16048-KB7-901	010-105
NT650 Hawk GT	88-91	16048-MR1-305	010-115
CB750C Custom	80-82	16048-443-901	010-104

### Honda Street

Model	Year	OEM Reference Air Cut-Off Valve	Order Number
CB750F Super Sport	1979	16048-428-305	010-102
CB750F Super Sport	80-82	16048-443-901	010-104
CB750K	1979	16048-428-305	010-102
CB750K	80-82	16048-443-901	010-104
CB750L LTD	1979	16048-428-305	010-102
CB750SC Nighthawk 750	82-83	16048-443-901	010-104
VFR750F	90-93	16048-MM5-671	010-119
VTF750R RC30	1990	16048-MR7-004	010-119
PC800 Pacific Coast	89-90	16048-MR1-305	010-115
PC800 Pacific Coast	94-98	16048-MR1-305	010-115
CB900C Custom	80-82	16048-443-901	010-104
CB900F Super Sport	81-82	16048-443-901	010-104
CB1000C Custom	1983	16048-KB7-901	010-105
CBR1000F Hurricane	87-88	16048-MM5-671	010-119
CB1100F Super Sport	1983	16048-KB7-901	010-105
GL1100 Gold Wing	80-83	16048-443-901	010-104
GL1100A Gold Wing Aspencade	82-83	16048-443-901	010-104
GL1100I Gold Wing Interstate	80-83	16048-443-901	010-104
ST1100	91-02	16048-MM5-671	010-119
ST1100A ABS	92-02	16048-MM5-671	010-119
VT1100C Shadow 1100	1987	16048-MM8-405	010-114
VT1100C Shadow 1100	88-90	16048-MM8-772	010-114
VT1100C Shadow 1100	92-96	16048-MM8-772	010-114
VT1100C Shadow 1100 Spirit	97-03	16048-MAH-670	010-114
VT1100C2 Shadow 1100 ACE	95-99	16048-MAH-670	010-114
VT1100C2 Shadow Sabre	00-03	16048-MAH-610	010-114
VT1100C2-2 Shadow 1100	1997	16048-MAH-670	010-114
VT1100C3 Shadow Aero	98-02	16048-MAH-610	010-114
VT1100D2 Shadow 1100 ACE	1999	16048-MAH-670	010-114
VT1100T Shadow ACE Tourer	98-01	16048-MAH-610	010-114

### Honda Dual Sport & Offroad

CRF230F	04-09	16048-KB7-901	010-105
XL250R Dual Sport	82-83	16048-KB7-901	010-105
XL250S Dual Sport	78-79	16048-413-004	010-103
XL250S Dual Sport	80-81	16048-443-901	010-104
XR250	1979	16048-428-305	010-102
XR250	1980	16048-443-901	010-104
XR250R	81-82	16048-443-901	010-104
XR250R	86-04	16048-KB7-901	010-105
XR350R	1985	16048-KB7-901	010-105
XL500R Dual Sport	1982	16048-KB7-901	010-105
XL500S Dual Sport	79-81	16048-443-901	010-104
XR500	79-80	16048-443-901	010-104
XR500R	81-82	16048-443-901	010-104
XR600R	88-00	16048-KB7-901	010-105



010-115



010-119



010-109



010-110



010-113

## Kawasaki Street

Model	Year	OEM Reference Air Cut-Off Valve	Order Number
EL250B2/B3 Eliminator	88-89	43028-0016	010-108
EL250E1 250HS Eliminator	91-94	43028-0016	010-108
EX250E1/E2 Ninja 250R	86-87	43028-0016	010-108
EX250F1/F2/F3 Ninja 250R	88-90	43028-0016	010-108
EX250F6-F19 Ninja 250R	92-05	43028-0016	010-108
EX250F6F/F7F Ninja 250R	06-07	43028-0016	010-108
EX250J8F/J9F Ninja 250R	08-09	43028-0016	010-108
EX250JAF/JBF/JCF Ninja 250R	10-12	43028-0016	010-108
KL600A1 KLR600 Dual Sport	1984	43028-0016	010-108
KL600B1/B2 KLR600 Dual Sport	85-86	43028-0016	010-108
KL650A1-A19 KLR650 Dual Sport	87-05	43028-0016	010-108
KL650A6F/A7 KLR650 Dual Sport	06-07	43028-0016	010-108
KL650E8F/E9F KLR650 Dual Sport	08-09	43028-0016	010-108
KL650EAF/EBF/ECF KLR650	10-12	43028-0016	010-108
KL650B2/B3 Tengai KLR650	90-91	43028-0016	010-108
KLX650C1/C2/C3/C4 Dual Sport	93-96	43028-0016	010-108
VN700A1 Vulcan 700	1985	43028-0016	010-108
VN750A2-A21 Vulcan 750	86-05	43028-0016	010-108
VN750A6F Vulcan 750	2006	43028-0016	010-108
VN800A1-A10 Vulcan 800	95-05	43028-0016	010-109
VN800B1-B10 Vulcan 800 Classic	96-05	43028-0016	010-109
VN800C1/C2 Vulcan 800 Drifter	99-00	43028-0016	010-109
VN800E1-E5 Vulcan 800 Drifter	01-05	43028-0016	010-109
VN800E6F Vulcan 800 Drifter	2006	43028-0016	010-109
ZG1000A1-A20 Concours	86-05	43028-0016	010-108
ZG1000A6F Concours	2006	43028-0016	010-108
ZL1000A1 Eliminator	1987	43028-0016	010-108
VN1500A1-A9 Vulcan 88	87-95	43028-0016	010-108
VN1500A10-A13 Vulcan 1500	96-99	43028-0016	010-108
VN1500B1/B2/B3/B4 Vulcan 88 SE	87-90	43028-0016	010-108
VN1500C3/C4 Vulcan 1500L	96-97	43028-0016	010-108
VN1500D1/D2 Vulcan 1500 Classic	96-97	43028-0016	010-108
VN1500E1-E7 Vulcan 1500 Classic	98-04	43028-0016	010-109
VN1500G Vulcan 1500 Nomad	99-01	43028-0016	010-109

## Kawasaki Dual Sport & Offroad

KLX300A2-A10 KLX300R	97-05	43028-0016	010-108
KLX300A6F KLX300R	2006	43028-0016	010-108
KLX400A1 KLX400SR Dual Sport	2003	43028-S003	010-108
KLX400A2 KLX400SR (Canada)	2004	43028-S003	010-108
KL600A1 KLR600 Dual Sport	1984	43028-0016	010-108
KL600B1/B2 KLR600 Dual Sport	85-86	43028-0016	010-108
KL650A1-A19 KLR650 Dual Sport	87-05	43028-0016	010-108
KL650A6F/A7 KLR650 Dual Sport	06-07	43028-0016	010-108
KL650E8F/E9F KLR650 Dual Sport	08-09	43028-0016	010-108
KL650EAF/EBF/ECF KLR650	10-12	43028-0016	010-108
KL650B2/B3 Tengai KLR650	90-91	43028-0016	010-108
KLX650C1/C2/C3/C4 Dual Sport	93-96	43028-0016	010-108

## Suzuki Street

Model	Year	OEM Reference Air Cut-Off Valve	Order Number
SV650X/Y/K1/K2	99-02	13480-10F00	010-113
SV650SX/SY/SK1/SK2	99-02	13480-10F00	010-113
GV700GLF/GLF2 Madura	1985	13480-05A10	010-110
VS700GLEFG/GLEFH Intruder	86-87	13480-05A10	010-110
VS700GLEPG/GLEPH Intruder	86-87	13480-05A10	010-110
VS700GLFG/GLFH Intruder	86-87	13480-05A10	010-110
VS700GLPG/GLPH Intruder	86-87	13480-05A10	010-110
VS750GLPJ/GLPK Intruder	88-89	13480-05A10	010-110
VS750GLPL/GLPM Intruder	90-91	13480-05A10	010-110
Boulevard S50K5/K6/K7 (VS800)	05-07	13480-05A10	010-120
Boulevard S50K8/K9 (VS800)	08-09	13480-05A10	010-120
VS800GLN/GLP/GLR Intruder	92-94	13480-05A10	010-120
VS800GLS/GLT/GLV Intruder	95-97	13480-05A10	010-120
VS800GLW/GLX/GLY Intruder	98-00	13480-05A10	010-120
VS800GLK1/GLK2 Intruder	01-02	13480-05A10	010-120
VS800GLK3/GLK4 Intruder	03-04	13480-05A10	010-120
VZ800V/W/X/Y Marauder	97-00	13480-05A10	010-120
VZ800K1/K2/K3/K4 Marauder	01-04	13480-05A10	010-120
VX800L/M/N/P	90-93	13480-05A10	010-120
GV1200GLF/GLF2/GLG Madura	85-86	13480-05A10	010-110
Boulevard S83K5/K6/K7 (VS1400)	05-07	13480-05A10	010-122
Boulevard S83K8/K9 (VS1400)	08-09	13480-05A10	010-122
GV1400GCG/GCH Cavalacade LX	86-87	13480-05A10	010-110
GV1400GDG/GDH/Cavalacade LX	86-87	13480-05A10	010-110
GV1400GDJ/GDK Cavalacade LX	88-89	13480-05A10	010-110
GV1400GTG/GTH Cavalacade	86-87	13480-05A10	010-110
VS1400GLFH Intruder	1987	13480-05A10	010-122
VS1400GLPH/GLPJ Intruder	87-88	13480-05A10	010-122
VS1400GLPL/GLPM/GLPN Intruder	90-92	13480-05A10	010-122
VS1400GLPP/GLPR/GLPS Intruder	93-95	13480-05A10	010-122
VS1400GLPT/GLPV/GLPW	96-98	13480-05A10	010-122
VS1400GLPX/GLPY Intruder	99-00	13480-05A10	010-122
VS1400GLPK1/GLPK2 Intruder	01-02	13480-05A10	010-122
VS1400GLPK1/GLPK2 Intruder	03-04	13480-05A10	010-122



010-120



010-122

# KEIHIN & MIKUNI Air Cut-Off Valves Sets



010-108



010-110



010-113



010-111

## Suzuki ATV

Model	Year	OEM Reference Air Cut-Off Valve	Order Number
LT-A400FK3-FK7 Eiger 4WD Automatic	03-07	13480-38F00	010-108
LT-A400FK2/FK3 Eiger 4WD Auto	02-03	13480-38F00	010-108
LT-A400FK4/FK5 Eiger 4WD Auto	04-05	13480-38F00	010-108
LT-A400FK6/FK7 Eiger 4WD Auto	06-07	13480-38F00	010-108
LT-A400FK8/FK9 Eiger 4WD Auto	08-09	13480-38F00	010-108
LT-A400K2/K3/K4 2WD Eiger Auto	02-04	13480-38F00	010-108
LT-F400K2/K3/K4 2WD Eiger	02-04	13480-38F00	010-108
LT-F400K5/K6/K7 2WD Eiger	05-07	13480-38F00	010-108
LT-F400K8 King Quad 2WD STD	2008	13480-38F00	010-108
LT-F400FK2/FK3/FK4 4WD Eiger	02-04	13480-38F00	010-108
LT-F400FK5/FK6/FK7 4WD Eiger	05-07	13480-38F00	010-108
LT-A500FK2/FK3 Vinson 4WD Auto	04-05	13480-38F00	010-108
LT-500FK6/FK7 Vinson 4WD Auto	06-07	13480-38F00	010-108
LT-F500FK3/FK4 Vinson 4WD Manual	03-04	13480-38F00	010-108
LT-F500FK5/FK6 Vinson 4WD Manual	05-06	13480-38F00	010-108
LT-F500FK7 Vinson 4WD Manual	2007	13480-38F00	010-108

## Suzuki Offroad

DR-Z400EY/EK1-EK3 (50 State)	00-03	13480-29F00	010-108
DR-Z400EK4-E7 (49 State only)	04-07	13480-29F00	010-108
DR-Z400Y/K1/K2/K3 (50 State)	00-03	13480-29F00	010-108
DR-Z400K4/K5/K6 (49 State only)	04-06	13480-29F00	010-108

Note: DR-Z models shown use Keihin FCR-H carburetors

## Yamaha Street

XT225D/DC-J/JC Serrow	92-97	3LD-1490H-00	010-110
XT225K/KC-W/WC Serrow	98-07	26H-1490H-00	010-110
XVS650A V-Star 650 Classic	98-05	22V-14940-00	010-110
XVS650K/KC-S/SC V-Star Custom	98-04	22V-14940-00	010-110
XVS650T-F V-Star Custom	2005	22V-14940-00	010-110
XVS650TC-F V-Star 650 Custom	2005	22V-14940-00	010-110
XVS650T/TC V-Star Midnight Custom	2005	22V-14940-00	010-110
XVS650AT V-Star 650 Silverado	03-05	22V-14940-00	010-110
XV750U Virago 750* (49 state only)	1988	3CF-1490H-00	010-111
* not used on CA models			
XV750W/WC-G/GC Virago 750	89-95	3CF-1490H-00	010-111
XV750H1/HC1-J1/JC1 Virago 750	96-97	3CF-1490H-00	010-111
TDM850D/DC/E/EC	92-93	3LD-1490H-00	010-110
FZS1000N/NC-T/TC FZ-1	01-05	5AP-14940-00	010-113
FZS1000SPR/SPRC FZ-1	2003	5AP-14940-00	010-113
XV1100U/UC-L/LC Virago 1100	88-99	3CF-1490H-00	010-111
XV1100S Virago 1100 Special	96-98	3CF-1490H-00	010-111
XVS1100A V-Star 1100 Classic	00-09	5EL-1490H-00	010-113

## Yamaha Street

Model	Year	OEM Reference Air Cut-Off Valve	Order Number
XVS1100L/LC-YCR/YR V-Star 1100 Custom	99-09	5EL-1490H-00	010-113
XVS1100T/TC-YCB/YB V-Star 1100 Midnight Custom	05-09	5EL-1490H-00	010-113
XVS1100ATR/ATRC-ATYCL/ATYL V-Star 1100 Silverado	03-09	5EL-1490H-00	010-113
VMX12N/NC/VVC V-Max	85-86	3LD-1490H-00	010-110
VMX12U/UC-J/JC V-Max	88-97	3LD-1490H-00	010-110
VMX12K/KC-W1/W1C V-Max	98-07	26H-1490H-00	010-110
XVZ12DKC2 Venture Royale	1984	3LD-1490 H-00	010-110
XVZ12DL/DLC/DN Venture Royale	84-85	3LD-1490H-00	010-110
XVZ12TK/KC2/L/LC Venture	83-84	3LD-1490H-00	010-110
XVZ13DS/DSC-DE/ DEC Venture Royale	86-93	3LD-1490H-00	010-110
XVZ13T/TC/U/UC Venture	87-88	3LD-1490H-00	010-110
XVZ13TFSPC/TFSP-TFMWC	02-07	5AP-14940-00	010-113
Royal Star Midnight Venture			
XVZ13CTMV/CTMV-CTMWC	06-07	5AP-14940-00	010-113
Royal Star Midnight Tour Deluxe			
XVZ13CT Royal Star Tour Deluxe	05-09	5AP-14940-00	010-113
XVZ13CTS Royal Star Tour Deluxe S	08-10	5AP-14940-00	010-113
XVZ13TF Royal Star Venture	99-09	5AP-14940-00	010-113
XVZ13TFS/TFSMC	2000	5AP-14940-00	010-113
Royal Star Venture MM			
XVZ13TFSM/TFSMC/TFSM	2000	5AP-14940-00	010-113
Royal Star Venture MM L.E.			
XVZ13TFS Royal Star Venture S	08-12	5AP-14940-00	010-113

## Yamaha Side x Side

YXR450FAVGR Rhino 450 4WD	2006	5EL-1490H-00	010-113
YXR450FAHV Rhino 450 Real Tree	2006	5EL-1490H-00	010-113
YXR450FW Rhino 450	2007	5EL-1490H-00	010-113
YXR450FHW Rhino 450 Hunter	2007	5EL-1490H-00	010-113
YXR450FSEW/FSPX Rhino 450 SE Special Edition	07-08	5EL-1490H-00	010-113
YXR450FXGR/FXR Rhino 450	2008	5EL-1490H-00	010-113
YXR450FHX Rhino 450 Hunter	2008	5EL-1490H-00	010-113
YXR450FX/FX-B/FX-C Rhino 450	2008	5EL-1490H-00	010-113
YXR450FYGR/FYR Rhino 450	2009	5EL-1490H-00	010-113
YXR450FHY Rhino 450 Hunter	2009	5EL-1490H-00	010-113

## Yamaha ATV

YFM250B Big Bear 250	07-09	5EL-1490H-00	010-113
YFM250X Bear Tracker 250 Realtree	01-02	5EL-1490H-00	010-113
YFM250X Bear Tracker 2WD	99-04	26H-1490H-00	010-110
YFM350A Bruin 350 2WD Auto	2004	5EL-1490H-00	010-113
YFM350B Bruin 350 2WD	05-06	5EL-1490H-00	010-113
YFM350ER Moto-4	87-90	3LD-1490H-00	010-110
YFM350ER Moto-4	92-95	3LD-1490H-00	010-110





010-118



## Yamaha ATV

Model	Year	OEM Reference Air Cut-Off Valve	Order Number
YFM350FA Bruin 350 4WD	04-06	5EL-1490H-00	010-113
YFM350FG Grizzly 350 4WD Hunter	08-12	5EL-1490H-00	010-113
YFM350FGI Grizzly 350 IRS 4WD	07-11	5EL-1490H-00	010-113
YFM350FH Big Bear 4WD	87-97	3LD-1490H-00	010-110
YFM350FH Big Bear 4WD	98-99	26H-1490H-00	010-110
YFM350FX Wolverine 4WD	95-97	3LD-1490H-00	010-110
YFM350FX Wolverine 4WD	98-05	26H-1490H-00	010-110
YFM350G Grizzly 350 2WD	07-11	5EL-1490H-00	010-113
YFM350U Big Bear 2WD	96-97	3LD-1490H-00	010-110
YFM350U Big Bear 2WD	98-99	26H-1490H-00	010-110
YFM350X Warrior	87-97	3LD-1490H-00	010-110
YFM350X Warrior	98-04	26H-1490H-00	010-110
YFM350X Wolverine 350 2WD	06-09	5EL-1490H-00	010-113
YFP350U Terra Pro	1988	3LD-1490H-00	010-110
YFM400A Kodiak 2WD	00-01	5EL-1490H-00	010-113
YFM400FAH Kodiak 4WD Hunter	01-02	5EL-1490H-00	010-113
YFM400FA Kodiak 4WD	00-02	5AP-14940-00	010-113
YFM400FBA Big Bear 400 4WD	07-11	5EL-1490H-00	010-113
YFM400F Big Bear 400 4WD	03-06	5EL-1490H-00	010-113
YFM400FW Kodiak 4WD	93-97	3LD-1490H-00	010-110
YFM400FW Kodiak 4WD	98-99	26H-1490H-00	010-110
YFM400M/MC/N/P Big Bear 2WD	00-02	5EL-1490H-00	010-113
YFM600FW Grizzly	98-00	4WV-14940-00	010-118
YFM600FH Grizzly Realtree	2000	4WV-14940-00	010-118
YFM600F Grizzly Realtree Hunter	2001	4WV-14940-00	010-118
YFM660R Raptor	01-05	5EL-1490H-00	010-113

## Yamaha Dual Sport & Offroad

TT225L/LC	1999	26H-1490H-00	010-110
TT-R225L/LC-S/SC	99-04	26H-1490H-00	010-110
XT225D/DC-J/JC Serow	92-97	3LD-1490H-00	010-110
XT225K/KC-JW/WC Serow	98-07	26H-1490H-00	010-110



## Sudco Air Cut-Off Valve Set

Three piece set includes **GENUINE** Keihin parts; diaphragm, spring, and o-ring. Fits Keihin FCR-MX, Kawasaki ZX900 and Yamaha Offroad with FCR-MX; WR250/400/426/450. **Made in Japan.**

Order No. **018-900**

## Kawasaki OEM Keihin with CVK Carburetor

Qt	OEM Reference	Description
1	43028-1085	Diaphragm
1	92145-1149	Spring
1	92093-1046	"U-Ring" O-ring

Applications	Year
ZX900C1/C2 Ninja ZX-9R	98-99
ZX900E1/E2 Ninja ZX-9R	00-01
ZX900F1/F2 Ninja ZX-9R	02-03

## Keihin FCR-MX37, 39, 41mm with Air Cut-Off

Qt	OEM Reference	Description
1	1201-858-2700	Diaphragm
1	1290-A19-2000	Spring
1	W9353-36000	"U-Ring" O-ring

## Yamaha OEM Keihin with FCR-MX Carburetor

Qt	OEM Reference	Description
1	5GS-14940-00-00	Diaphragm
1	5GS-14933-00-00	Spring
1	3TJ-14536-40-00	"U-Ring" O-ring

Applications	Year
--------------	------

ATV	Year
YFZ450S/T/V/W/W-B	04-07
YFZ450LES Limited Edition	2004
YFZ450SET/SPV/SEW/SPX	05-08
Special Edition	
YFZ450BBV/BBW	06-07
Bill Ballance Edition	
YFZ450SE2W/SP2X	07-08
Special Edition II	
YFZ450XL/XGY/YL/YW	08-09
YFZ450YL/YW	2009
YFZ450RYW/RYL	2009

Offroad	Year
WR250FN-FY	01-09
WR250FA/FB	11-12
WR400FM	2000
WR426FN/FP	01-02
WR450FR-FY/FA	03-11

# Fuel Injection Controller & Air/Fuel Ratio Monitor



## Dynatek (F.I.) Fuel Injection Controller

The Dyna Fuel Injection controller is a plug-in module that offers 3 user selectable base fuel curves. Designed to improve engine operation and can be modified to suit a wide variety of modifications. These adjustments are made via 3 potentiometers that adjust the fuel curve in the proper ranges for the application. Fuel mixture can be enriched or leaned as required. The Dyna F.I. Controller use the factory connectors for easy installation and there is no PC required for tuning or adjusting the fuel curves. There are no modifications to the stock ECU and removing the Dyna F.I. Controller returns the vehicle to the factory settings. Available for the following models:

### Metric Cruiser

#### Honda

Model	Year	Dynatek No.	Order No.
VTX1800 (all C, N & Retro models)	02-08	DFCM-1	<b>618-991</b>

#### Kawasaki

VN1500 Vulcan Classic, Vulcan Drifter	99-08	DFCM-2	<b>618-992</b>
VN1500 Vulcan Mean Streak & Nomad	99-08	DFCM-2	<b>618-992</b>
VN1600 Vulcan 1600 Mean Streak	04-08	DFCM-3	<b>618-993</b>
VN2000 Vulcan 2000	04-08	DFCM-4	<b>618-994</b>

#### Suzuki

VL800 Boulevard C50	05-08	DFCM-5	<b>618-995</b>
VZ800 Boulevard M50	05-08	DFCM-5	<b>618-995</b>
VL1500 Boulevard C90	05-09	DFCM-6	<b>618-996</b>
VZ1600K4 Marauder	03-08	DFCM-3	<b>618-993</b>

#### Yamaha

XV1700 Road Star Warrior	02-09	DFCM-7	<b>618-997</b>
--------------------------	-------	--------	----------------

### ATV

#### Bombardier

Model	Year	Dynatek No.	Order No.
Outlander 800	06-09	DFCA-5	<b>618-895</b>

#### Honda

TRX680 Rincon	06-09	DFCA-1	<b>618-891</b>
---------------	-------	--------	----------------

#### Polaris

500 EFI	2006	DFCA-6	<b>618-896</b>
700 Twin EFI	2004	DFCA-7	<b>618-897</b>
700 Twin EFI	05-08	DFCA-8	<b>618-898</b>
800 Twin EFI	05-08	DFCA-9	<b>618-899</b>

#### Suzuki

LT-R450	06-09	DFCA-2	<b>618-892</b>
LT700 King Quad	05-07	DFCA-3	<b>618-893</b>

#### Yamaha

YFM700 Raptor	06-09	DFCA-4	<b>618-894</b>
---------------	-------	--------	----------------

## K&N Air/Fuel Ratio Monitor

The K&N Air/Fuel Ratio Monitor is a precision instrument designed to aid the performance enthusiast make correct jetting decisions. The monitor measures the oxygen content of the exhaust gas and displays the relative air/fuel ratio information on an LED display. This device is the most economical exhaust analyzer available, enabling a tuner to see at a glance the air/fuel ratio of the engine at any load or throttle position. Two styles of monitor available, rectangular and round.

### Rectangular Mount Air/Fuel Ratio Monitor **005-202**

Mounts on any flat surface with an attached pedestal.  
Ideal for motorcycles or quick testing.

### Round Mount Air/Fuel Ratio Monitor **005-200**

Mounts in a 2" hole like a standard gauge for a permanent professional look

### Replacement Parts

Weld-on Sensor Fitting and Plug Kit (no sensor)	<b>005-275</b>
Sensor Fitting only (no sensor)	<b>005-280</b>
Sensor Plug only (no sensor)	<b>005-281</b>





## Sudco Pilot Screw Kit for Suzuki

GENUINE replacement parts. Four piece kit includes pilot screw, spring, washer and o-ring. Individual parts are also available.

Order No. **007-947**

Individual Parts (each)	Order No.
Pilot Screw	<b>007-632</b>
Spring	<b>007-631</b>
Washer	<b>002-856</b>
O-Ring	<b>002-858</b>

Model	Year
DR250 Offroad with TM33 Pumper Carb	90-93
DR350 Offroad with TM33 Pumper Carb	90-99
GSX-R1100W	93-98
GS1000/GS1100/GS1150	80-85



## Sudco Keihin FCR-MX Pilot Screw

Stock replacement pilot screw for Keihin FCR-MX carburetors. Sold each

Order No. **021-729**

Individual Parts (each)	Order No.
Keihin FCR-MX Pilot Screw Spring	<b>021-041</b>
Keihin FCR-MX Pilot Screw Washer	<b>021-045</b>
Keihin FCR-MX Pilot Screw O-Ring	<b>021-043</b>



## Tokyo mods FCR-MX Fuel Mixture Screw

Easily adjust the fuel mixture on your Keihin FCR carburetor. Dual O-rings to keep it in place. Machined from 6061 aluminum.

Application	Color	Order No.
Keihin FCR-MX	Red	<b>024-200R</b>
Keihin FCR-MX	Blue	<b>024-200B</b>
Keihin FCR-MX	Black	<b>024-200K</b>
Keihin FCR-MX	Mag	<b>024-200M</b>



**021-921**



**021-922**

## Sudco Blaster/Banshee Carburetor Caps

Sold as kits for Yamaha YFS200 Blaster, and YFZ350 Banshee.

YFZ350 Banshee Kit  
Includes 2 caps, 2 cable adjuster screws and 2 locknuts. Order No. **021-921**

YFZ200 Blaster Kit  
Includes 1 cap, 1 cable adjuster screw and 1 locknut. Order No. **021-922**

Individual Replacement Parts

Description	Order No.
Cable Adjuster Screw with Locknut	<b>021-273</b>
Top Cap only VM34/27 (each)	<b>002-066</b>



## Motion Pro Yamaha Banshee/Blaster Idle Kit

Kit includes drill bit, taper thread tap, 2 idle adjuster screws with lock nuts and installation instructions. Install a standard Mikuni idle adjuster screw into Yamaha YFS200 Blaster and YFZ350 Banshee carburetors.

Order No. **021-920**

Individual Parts (each)	Order No.
Idle Adjuster Screw only	<b>002-184</b>
Idle Adjuster Screw Locknut only	<b>002-065</b>



## Sudco Banshee Carburetor Cable Kits

Fits stock thumb throttle. Sold as a kit for Yamaha YFZ350 Banshee. Two kits available.

YFZ350 Banshee Carburetor Cable Kit without Idle Screws

Order No. **021-923**  
Includes 2 caps, 2 cable adjuster screws, 2 locknuts and throttle cable for stock thumb throttle.

YFZ350 Banshee Carburetor Cable Kit with Idle Screws

Order No. **021-924**  
Includes 2 caps, 2 cable adjuster screws, 4 locknuts, throttle cable for stock thumb throttle and idle screws.

Individual Replacement Parts

Description	Order No.
Cable Adjuster Screw with Locknut	<b>021-273</b>
Idle Adjuster Screw only	<b>002-184</b>
Idle Adjuster Screw Locknut only	<b>002-065</b>
Top Cap only VM34/27 (each)	<b>002-066</b>
Throttle Cable for stock Thumb Throttle	<b>021-278</b>

# Sudco Carburetor Rebuild Kits

## Sudco Carburetor Rebuild Kits

Each kit contains genuine Keihin and Mikuni parts to rebuild one carburetor body. **Made in Japan.** **Note: 018-851 and 018-852** rebuild kits include parts for 4 carb bodies.

H - Horizontal Carburetor

D - Downdraft Carburetor

### Keihin

Application	Order No.
26-33 CR Special (4 carb bodies)	018-851
35-39 CR Special (4 carb bodies)	018-852
28-33 FCR-D	018-865
28-33 FCR-H	018-865
35-39 FCR-D	018-866
41 FCR-D	018-867
35-39 FCR-H	018-870
41 FCR-H	018-871

### Mikuni

Application	Order No.
HS40 (TM40-6)	002-985
HSR42/45	002-989
HSR48	002-982
TM33-6012 Pumper	025-661
TM36-68	007-940
VM26-606 with side choke	025-660
Yamaha OEM BSR44 for YXR660 Rhino	025-662

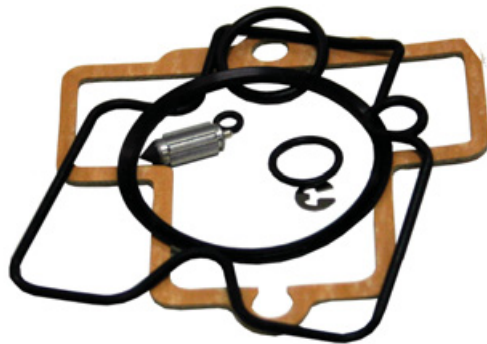

018-866



002-985

## Sudco Watercraft Carburetor Rebuild Kits

Each kit contains genuine Keihin and Mikuni parts to rebuild one carburetor body. **Made in Japan.** See Watercraft section for additional details and replacement parts.

### Keihin

Application	Keihin No.	Order No.
CDK28mm	9000-981-0100	025-625
CDKII 38, 40, 42	1000-A47-0100	025-627

### Mikuni

Application	Mikuni No.	Order No.
BN34, BN38 & BN44 Round Pump Carb	MK-BN38/44	025-650
BN38, BN44 Square Pump Carb	MK-BN38/44 SPR	025-651
BN38I, BN40I Square Pump Carb	MK-BN38/44 SPR	025-651
BN46 Square Pump Carb	MK-BN38/44 SPR	025-651
BN44I Square Pump Carb, Yamaha	MK-BN44I	025-653
BN46I, Sea Doo	MK-BN46I	025-654



025-651



025-653

## Vintage Street Carburetor Repair Kits

Each kit contains necessary parts to rebuild one OEM carburetor body.  
**Made in Japan. Note- Check all parts before installation.**



025-610

### Honda

Model	Carburetor	Year	Order No.
CB72 Hawk 250	PW22	61-66	<a href="#">025-610</a>
CL72 Scrambler 250		62-65	<a href="#">025-611</a>
CB77 Super Hawk 305	PW26	61-68	<a href="#">025-610</a>
CL77 Scrambler 305		65-68	<a href="#">025-611</a>
CB350F Super Sport	20mm	72-74	<a href="#">025-609</a>
CB400F Super Sport		75-77	<a href="#">025-612</a>
CB750K0/K1/K2	28mm	69-72	<a href="#">025-613</a>

### Kawasaki

S1A/S1B/S1C-250	VM22SC	73-75	<a href="#">025-680</a>
KH250A5	VM22SC	1976	<a href="#">025-680</a>
S2/S2A-350	VM24SC	72-73	<a href="#">025-681</a>
S3/S3A-400	VM26SC	74-75	<a href="#">025-682</a>
KH400	VM26SC	76-78	<a href="#">025-682</a>
H1/A/C-500 Mach III	VM28SC	69-72	<a href="#">025-603</a>
H1B/D/E/F-500	VM28SC	73-75	<a href="#">025-601</a>
H2/A-750 Mach IV	VM30SS	72-73	<a href="#">025-602</a>
Z1/A/B-900	VM28SS	73-75	<a href="#">025-600</a>
KZ1000A1/A2	VM26SS	77-78	<a href="#">025-604</a>
KZ1000A3/A3A MKII	VM28SS	1979	<a href="#">025-605</a>
KZ1000A4 MKII	VM28SS	1980	<a href="#">025-606</a>
KZ1000B1/B2 LTD	VM26SS	77-78	<a href="#">025-604</a>
KZ1000B3 LTD	VM26SS	1979	<a href="#">025-605</a>
KZ1000B4 LTD	VM28SS	1980	<a href="#">025-606</a>
KZ1000C1/C1A Police	VM26SS	1978	<a href="#">025-604</a>
KZ1000C2 Police	VM26SS	1979	<a href="#">025-606</a>
KZ1000C3/C4 Police	VM28SS	80-81	<a href="#">025-606</a>
KZ1000D1 Z1R	VM28SS	1978	<a href="#">025-604</a>
KZ1000D3 Z1R	VM28SS	1980	<a href="#">025-606</a>
KZ1000E1/E2 Shaft ST	VM28SS	79-80	<a href="#">025-605</a>
KZ1000J1/J2	BS34	81-82	<a href="#">025-614</a>
KZ1000K1/K2 LTD	BS34	81-82	<a href="#">025-614</a>
KZ1000M1/M2 CSR	BS34	81-82	<a href="#">025-614</a>
KZ1000P1-P21 Police	BS34	82-02	<a href="#">025-614</a>
KZ1000R1/R2 Replica	BS34	82-83	<a href="#">025-614</a>



### Suzuki

Model	Carburetor	Year	Order No.
GT380L/M/A/B Sebring	VM24SC	74-77	<a href="#">025-425</a>
GT750L/M/A/B Lemans	BS	74-77	<a href="#">025-426</a>

### Yamaha

RD350/A/B	VM28SC	73-75	<a href="#">025-623</a>
RD400C/D/E	VM28SC	76-78	<a href="#">025-624</a>



025-600



025-426

# ATV Carburetor Repair Kits



025-001



025-607

## Shindy Products ATV Carburetor Repair Kits

Complete kits to rebuild one **OEM carburetor**. Each kit contains necessary gaskets, o-rings, needle valve or needle valve set and jets. Carburetor Repair Kits for YFM660 Raptor and Kawasaki KVF650 kits contain parts for two carburetors. **Made in Japan.**

### Honda

Model	Carburetor	Year	Order No.
ATC70	PB13	78-85	025-001
ATC90	PB15	70-71	025-003
ATC90K1/K2/K3	PB15	72-75	025-003
ATC90	PB15	76-78	025-003
TRX90 Fourtrax 90		93-98	025-084
ATC110	PB18	79-83	025-005
ATC110	PB18	84-85	025-061
ATC125M	PB20	84-85	025-062
TRX125 Fourtrax	PB	85-86	025-050
TRX125 Fourtrax	PB18	87-88	025-063
ATC185	PD	1980	025-009
ATC185S	PD	81-83	025-009
ATC200	PD	81-82	025-008
ATC200	PD	1983	025-009
ATC200E Big Red	PD22	82-83	025-064
ATC200ES Big Red	PD22	1984	025-064
ATC200M	PD22	84-85	025-064
ATC200S	PD22	84-86	025-065
ATC200X	PD24	83-85	025-012
ATC200X	PD	86-87	025-014
TRX200 Fourtrax 200	PD20	90-91	025-066
TRX200D Fourtrax 200 Type II		1991	025-066
TRX200D Fourtrax 200 Type II	PD	92-93	025-067
TRX200D Fourtrax 200 Type II		94-97	025-068
TRX200SX Fourtrax	PD22	87-88	025-069
ATC250R	PE27	81-82	025-017
ATC250R	PE30	83-84	025-018
ATC250R	PE37	1985	025-019
ATC250ES Big Red	QA27	85-87	025-029
ATC250SX	QA27	1985	025-070
TRX250 Fourtrax 250	QA27	1985	025-071
TRX250 Fourtrax 250	QA27	86-87	025-072
TRX250EX Sportrax 250EX	PD	01-04	025-085
TRX250R Fourtrax 250R	PJ34	86-87	025-060
TRX250R Fourtrax 250R	PJ34	1988	025-073
TRX250X	QB29	1988	025-075
TRX300 Fourtrax 300	VE29	1991	025-074
TRX300 Fourtrax 300	VE32	1992	025-076
TRX300 Fourtrax 300	VE32	93-95	025-078
TRX300EX Fourtrax 300EX	QB	93-98	025-081
TRX300FW Fourtrax 300 4x4	VE33	1988	025-075
TRX300FW Fourtrax 300 4x4	VE29	91-92	025-076
TRX300FW Fourtrax 300 4x4	VE32	93-95	025-078
ATC350X	QA31	1985	025-035
TRX350 Fourtrax 4x4	QA31	86-87	025-079

### Honda

Model	Carburetor	Year	Order No.
TRX350FE Fourtrax Rancher 4x4 ES	VE	00-03	025-082
TRX350FM Fourtrax Rancher 4x4	VE	00-03	025-082
TRX350TE Fourtrax Rancher ES	VE	00-03	025-082
TRX350TM Fourtrax Rancher	VE	00-03	025-082
TRX350D Fourtrax Foreman 4x4		87-89	025-079
TRX400EX Fourtrax 400EX	QB	99-00	025-087
TRX400EX Sportrax 400EX		01-04	025-087
TRX400FA Fourtrax Rancher AT		04-05	025-088
TRX400FGA Fourtrax Rancher AT GPscope		04-05	025-088
TRX400FW Fourtrax Foreman	VE	95-00	025-080
TRX450ES Fourtrax Foreman ES	VE	98-01	025-083
TRX450FE Fourtrax Foreman ES	VE	02-03	025-083
TRX450FM Fourtrax Foreman S	VE	02-03	025-083
TRX450S Fourtrax Foreman S	VE	98-01	025-083
TRX500FA Fourtrax Rubicon	VE	01-04	025-086
TRX650FA Fourtrax Rincon		03-05	025-089
TRX650FGA Fourtrax Rincon GPscope		03-05	025-089

### Kawasaki

KLF220A1-A11 Bayou 220	VM24SS	88-98	025-607
KLF250A1/A2/A3/A6F/A7F Bayou	VM24SS	03-07	025-675
KSF250A!-A11 Mojave 250	CVK34	87-97	025-618
KLF300A1/A2 Bayou 300	CVK32	86-87	025-615
KLF300B2-B8 Bayou 300	CVK32	89-95	025-616
KLF300C1-C7 Bayou 300 4x4	CVK32	89-95	025-617
KVF300A1-A4 Prairie	CVK32	99-02	025-621
KVF360A1/A2/A3 Prairie 360 4x4	CVK34	03-05	025-676
KVF360A6F/A7F Prairie 360 4x4	CVK34	06-07	025-676
KVF360B1/B2/B3 Prairie 360	CVK34	03-05	025-676
KVF360B6F/B7F Prairie 360	CVK34	06-07	025-676
KVF360C1 Prairie 360 4x4	CVK34	2003	025-676
KVF360C2/C3 Prairie 360 4x4	CVK34	04-05	025-676
Hardwoods Green HD			
KVF360C6F/C7F Prairie 360 4x4	CVK34	06-07	025-676
Hardwoods Green HD			
KLF400B1/B2/B3 Bayou 400 4x4	CVK32	93-95	025-619
KLF400B4-B7 Bayou 400 4x4	CVK32	96-99	025-620
KVF400D1-D4 Prairie 400	CVK34	99-02	025-622
KVF650 (for 2 carbs)		02-07	025-677
KVF650A1/A2 Prairie 650 4x4	CVKR-D32	02-03	025-677
KVF650B1/B2 Prairie 650 4x4	CVKR-D32	02-03	025-677
KVF650D1/D6F/D7F (for 2 carbs)	CVKR-D32	02-03	025-677
Brute Force 4x4			
KVF650E Brute Force 650 4x4	CVKR-D	05-07	025-677
Hardwoods Green HD			



025-702



025-416

## Polaris

Model	Carburetor	Year	Order No.
Trail Blazer		90-95	025-701
Trail Blazer 2x4		89-93	025-701
Trail Boss 4x4		89-93	025-701
Trail Boss		89-99	025-701
Xplorer 300		96-99	025-702
Xpress 300		96-99	025-702
4x4 300		94-95	025-702
2x4 300		94-95	025-702
Trail Boss 4x4 350L	VM34SS	92-93	025-703
Trail Boss 2x4 350L	VM34SS	92-93	025-703
Sportsman 4x4		1993	025-703
Xplorer 400 4x4		1995	025-704
Sport 400		94-95	025-704
4x4 400L		1994	025-704
2x4 400L		1994	025-704
Sportsman 4x4		94-95	025-704
Trail Blazer		96-00	025-705
Xplorer 4x4		2000	025-705
Scrambler 400 2x4		00-01	025-706
Scrambler 400 4x4		98-00	025-706
Scrambler 400L		1997	025-706
Xplorer 400		97-02	025-707
Scrambler 500	BSR33	2000	025-708
Scrambler 500 2x4	BSR33	01-02	025-708
Scrambler 500 4x4	BSR33	01-02	025-708
Scrambler 500 4x4 Freedom	BSR33	2002	025-708
Sportsman 500	BSR33	2002	025-708

## Suzuki

LT80H-W Quadrunner	VM16SH	87-98	025-416
ALT125D/E/F/G		83-86	025-407
LT125D/E/F/G/H		83-87	025-407
LT-F160M/N/P/R/S/T/V/W	VM20SS	91-98	025-414
LTF230G/H		86-87	025-410
LT230GEF/GEG Quadrunner		85-86	025-410
LT230EK-EP Quadrunner	VM24SS	89-93	025-411
LT230SF-SJ Quadrunner		85-88	025-402
LT-F250L-T Quadrunner	BST31SS	90-96	025-413
LT-F250FX-FK2 Quadrunner		99-02	025-417
LT250RF/RG Quadracer	TM34SS	85-86	025-405
LT-F250J/K Quadrunner	BST31SS	88-89	025-412
LT-4WDH/J/K		87-89	025-412
LT4WDL-WDT		90-96	025-413
LT-F4WDXM-WDXW King Quad	BST31SS	91-98	025-415
LT-A400FK2-FK7 Eiger 4WD Auto	CVK32	02-07	025-419
LT-F400K2/K3/K4 Eiger 2WD Auto	CVK32	02-04	025-419
LT-F400FK2-FK7 Eiger 4WD	CVK32	02-07	025-419

## Suzuki

Model	Carburetor	Year	Order No.
LT-F400K2-K7 Eiger 2WD	CVK32	02-04	025-419
LT-F400K2/K3/K4 Eiger 2WD	CVK32	02-04	025-419
LT-F400K7 Eiger 2WD	CVK32	2007	025-419
LTF500FW-FK2 Quadrunner	BSR	98-02	025-418



025-211

## Yamaha

YFM80D/E/F Badger		92-01	025-218
YFM80 Raptor		02-04	025-218
YFM200DXS-DXW Moto-4		86-89	025-219
YFS200U-P Blaster	VM26	88-02	025-210
YFB250D/E/F/G/H Timberwolf		92-95	025-215
YFB250UH/UJ/UK Timberwolf		96-98	025-215
YFB250FWTimberwolf		94-98	025-215
YFM250W/A/B Moto-4		89-91	025-211
YFM250X Beartracker		99-04	025-224
YFM350F/FW Big Bear		89-92	025-213
YFM350ER Moto-4		89-93	025-213
YFM350XU-XR Warrior	36	88-02	025-216
YFZ350T-P Banshee	VM26	88-02	025-217
YFM400FWE/FWF Kodiak		93-94	025-213
YFM400FWG Kodiak		1995	025-213
YFM400F Kodiak 4WD		94-98	025-220
YFM400F Kodiak 4WD	BSR33	00-04	025-221
YFM450 Kodiak	BSR33	03-04	025-225
YFM600FW Grizzly		98-01	025-222
YFM660FP/FPS/FR/FS/FAT Grizzly	BSR42	02-05	025-226
YFM660 Grizzly	BSR42	02-05	025-226
YFM660R Raptor (for 2 carbs)	BSR33	01-04	025-223

# Offroad Carburetor Repair Kits



020-112



007-951

## Sudco Offroad Carb Repair Kits

Sudco Carb Repair Kits include GENUINE replacement parts for one OEM carburetor. These kits do not include jets, jet needles or needle jets. *Made in Japan.*

### Honda

Model	Carburetor	Year	Order No.
CR85R	PWK28	05-08	020-112
CR85RB	PWK28	05-08	020-112
CR125R	PJ34	85-89	020-115
CR125R	PJ34 & 36	90-99	020-313
CR250R	PJ36	1985	020-115
CR250R	PJ38	86-89	020-115
CR250R	PJ38	90-96	020-314
CR250R	PJ38	97-98	—
CR250R	PWK38	99-00	—
CRF450R	FCR-MX40	02-03	020-315
CR500R	PJ38	85-89	020-115
CR500R	PJ38	90-01	020-314

### Kawasaki

KX85A1/A2/A3/A4	PWK28	01-04	020-112
KX85A5/A6F/A7F/A8F/A9F	PWK28	05-09	020-112
KX85A9FA Monster Energy	PWK28	2009	020-112
KX85AAF/ABF/ACF	PWK28	10-12	020-112
KX100D1/D2/D3/D4	PWK28	01-04	020-112
KX100D5/D6F/D7F/D8F/D9F	PWK28	05-09	020-112
KX100D9FA Monster Energy	PWK28	2009	020-112
KX100DBF/DCF/DDF	PWK28	11-13	020-112
KX125F1/G1/H1/H2	PWK35	88-91	020-110
KX125J1/J2/K1/K2	PWK36	92-95	020-110
KX125K3/K4	PWK35	96-97	020-110
KDX200E1-E6	PWK35	89-94	020-110
KDX200H1-H11	PWK35	95-05	020-110
KDX200H6F	PWK35	2006	020-110
KDX220A4-A12	PWK33	97-05	020-110
KDX250D1/D2/D3/D4	PWK38	91-94	020-110
KX250F1	PWK39	1988	020-110
KX250G1/H1/H2/J1/J2	PWK38	89-93	020-110
KX250K1/K2/K3/K4	PWK38	94-97	020-110
KX250N1/N2/T6F/T7F (KX250F)	FCR37MX	04-07	020-317
KXF250A2 Tecate 2 ATV	PWK35	1988	020-110
KX450T6F/T7F (KX450F)	FCR40MX	06-07	020-317
KX500D1/E1-E16	PWK39	88-04	020-110

## Keihin

Model	Carburetor	Year	Order No.
FCR-MX37, 39 & 41mm			020-319
FCR-MX37, 39 & 41mm w/Air Cut Valve & Hot Start			020-320
FCR-MX37, 39 & 41mm w/Air Cut Valve & Hot Start/TPS			020-321
PJ34-38mm			020-115
PWK28mm			020-112
PWK33-41mm			020-110
PWK39mm Snowmobile			020-111
PWM38mm			020-120

## KTM

85 SX	PWK28	03-12	020-112
105 SX	PWK28	04-12	020-112

## Mikuni

VM26-606 spigot with side choke	VM26		025-660
TM33-8012 Pumper	TM33		025-661
TMS38 with 3.5 needle valve	TMS38		007-950
TMX35-1 with 3.5 needle valve			007-950
TMX38-18 & TMX38-27 w/3.5 N/V			007-950
TMS38 w/1.8 N/V	TMS38		007-951
TMX35-1, TMX38-18 & TMX38-27w/1.8 N/V			007-951
TMX35-1, TMX38-18 & TMX38-27w/1.8 N/V			007-951

## Suzuki

RM100K3	PWK28	2003	020-112
RM125J/K/L/M/N/P	TMS36	88-93	007-950
RM125R/S/T/V	PJ34 or 36	94-97	020-110
DR200G/H/J Offroad	TM26	86-88	025-661
DR250L/M/N/P Offroad	TM33	90-93	025-661
DR-Z250K1-K7 Offroad (49 state)	TM28SS	01-07	025-661
RM250J/K/L/M/N	TMS38	88-92	007-950
RM250P/R/S/T	PJ38	93-96	020-115
RM250V	PWK38	1997	020-110
RMX250K/L/M/N Offroad	TMS38	89-92	007-950
RMX250P/R/S/T/V/W Offroad	PJ38	93-98	020-115
RM-Z250K4/K5	FCR37MX	04-05	020-317
DR350L/M/N/P/R/S/T Offroad	TM33	90-96	025-661
DR350V/W/X Offroad (49 state)	TM33	97-99	025-661
RM-Z450K5/K6/K7	FCR40MX	05-07	020-317





020-120

## Yamaha

Model	Carburetor	Year	Order No.
YZ85P/R/S/T/W	PWK28	02-08	020-112
YZ125W/A/B/D/E1/F1	TMS36	89-94	007-950
YZ250FN/FP	FCR37MX	01-02	020-323
YZ250W/A/B/D/E1/F1	TMS38	89-94	007-950
YZ250G1	PWK38	1995	020-110
YZ250H1/J1/K1	PWM38	96-98	020-120
WR400FK/FLOffroad	FCR39-H	98-99	020-324
WR400FM Offroad	FCR39MX	2000	020-323
YZ400FK/FL	FCR39-H	98-99	020-324
WR426FN/FP	FCR39MX	01-02	020-323
YZ426FN/FP	FCR39MX	01-02	020-323
WR450FR/FS	FCR39MX	03-04	020-325
YZ450FR/FS	FCR39MX	03-04	020-325



## YXR660 Rhino Carburetor Rebuild Kit

Kit contains GENUINE Mikuni parts, all the necessary parts, diaphragms and gaskets to rebuild the Yamaha Rhino BSR carburetor. Sold as a kit. *Made in Japan.* Order No. **025-662**

## Yamaha Side x Side

Model	Carburetor	Year
YXR660FAS/FAT/FAV Rhino 660	BSR42	04-06
YXR660FAHS/FAHT Rhino 660	BSR42	04-05
Hardwoods Camo Hunter Edition		
YXR660FAHV Rhino 660	BSR42	2006
4WD Hunter		
YXR660FASEV Rhino 660 4WD	BSR42	2006
Special Edition		
YXR660FAVGR Rhino 660 4WD	BSR42	2006
YXR660FHW	BSR42	2007
YXR660FDUW	BSR42	2007
YXR660FSEW	BSR42	2007
YXR660FW	BSR42	2007



025-825

## Shindy Products Offroad Carburetor Repair Kits

Complete kits to rebuild one **OEM carburetor**. Each kit contains necessary gaskets, o-rings, needle valve or needle valve set and jets. *Made in Japan.*

## Honda

Model	Carburetor	Year	Order No.
CR80R	PE28	96-02	025-801
CR85R	PE28	03-04	025-801
CR125R	TMX36	00-01	025-802
CR125R	TMX38	02-03	025-803
CR250R	PJ38	99-00	025-804
CR250R	TMX38S	01-03	025-805
CRF250	FCR-MX	2004	025-806
CRF250R	FCR-MX	2005	025-807
CRF250R	FCR-MX	06-08	025-808
CRF450R	FCR-MX	02-04	025-809
CRF450R	FCR-MX	05-06	025-810
CRF450R	FCR-MX	07-08	025-811

## Kawasaki

KX85A1/A2/A3/A4/A5	PWK28	01-05	025-861
KX125L3	TMX36	2001	025-862
KX125L4	TMX38	2002	025-862
KX125M1/M2/M3	TMX38	03-05	025-863
KX250F	FCR-MX	04-08	025-865
KX250L2/L3/L4	PWK38S	00-02	025-864
KX250M1/M2	PWK38S	03-04	025-864
KX450F	FCR-MX	06-08	025-866

## Suzuki

RM85K2/K3/K4/K5/K6	PE28	02-06	025-841
RM125K1/K2/K3/K4/K5	TMX38S	01-05	025-842
RM250K1/K2/K3/K4/K5/K6	PWK38S	01-06	025-843
RMZ250	FCR-MX	05-06	025-865
RMZ250	FCR-MX	07-09	025-844
RMZ450	FCR-MX	05-07	025-845

## Yamaha

YZ80J1/K1/L/M1/N1	VM26	97-01	025-821
YZ85P/R/S	PWK28	02-04	025-822
YZ125L/M	TMX	99-00	025-823
YZ125P/R/S1	TMX38S	02-04	025-824
YZ250F	FCR-MX	01-02	025-827
YZ250F	FCR-MX	03-06	025-828
YZ250F	FCR-MX	07-08	025-829
YZ250M1/N	PWK38	00-01	025-825
YZ250P/R/S1	PWK38S	02-04	025-826
YZ426F	FCR-MX	00-02	025-830
YZ450F	FCR-MX	03-04	025-831
YZ450F	FCR-MX	05-08	025-832

# Carburetor Float & Float Pin

002-114



002-605



007-727

## Sudco Mikuni & Keihin Carburetor Float & Pin

Genuine Mikuni & Keihin carburetor float and pin.

Sold each. *Made in Japan.*

Parts are sold separately, order by **SUDCO** part number.

### Honda Offroad

Model	Year	Float	Float Pin
CR80R	84-02	018-397	018-670
CR80RB	96-02	018-397	018-670
CR85R	03-06	018-397	018-670
CR85RB	03-06	018-397	018-670
CR125R	84-99	018-110	018-670
CRF150R/RB	07-09	018-202	018-670
CRF150R/RB	2012	018-202	018-670
CR250R	84-00	018-110	018-670
CRF250R	04-05	018-202	018-670
CRF250X	04-09	018-202	018-670
CRF450R	02-06	018-202	018-670
CRF450X	05-09	018-202	018-670
CRF450X	2012	018-202	018-670
CR500R	84-01	018-110	018-670

### Kawasaki Street

A7-350 Avenger 2-stroke rotary valve	66-71	002-114	002-605
A7SS-350 Avenger SS	70-71	002-114	002-605
H1D/E/F-500 2-stroke triple	73-75	002-114	002-605
KH500A8 2-stroke triple	1976	002-114	002-605
H2/A/B/C-750 2-stroke triple	72-75	002-114	002-605
KZ650H2/H3 CSR	82-83	007-727	002-605
KZ700A1	1984	007-727	002-605
H2/A/B/C-750 2-stroke triple	72-75	002-114	002-605
KZ750K1/K2 LTD (2-cylinder)	83-84	007-727	002-605
KZ750L3	1983	007-727	002-605
KZ750M1 CSR (2-cylinder)	1982	007-727	002-605
KZ750R1 GPz	1982	007-727	002-605
ZX750A1/A2/A3 GPz	83-85	007-727	002-605
ZX750K1/K2 Ninja ZX-7R	92-93	021-051	018-670
ZX750M1/M2 Ninja ZX-7R	94-95	021-051	018-670
KZ1000J1/J2/J3	81-83	007-727	002-605
KZ1000K1/K2 LTD	81-82	007-727	002-605
KZ1000M1/M2 CSR	81-82	007-727	002-605
KZ1000P1-P21 Police	82-02	007-727	002-605
KZ1000P24 Police	2005	007-727	002-605
KZ1000R1/R2 Replica	82-83	007-727	002-605
KZ1100A1/A2/A3 Shaft	81-83	007-727	002-605
KZ1100D1/D2 Spectre	82-83	007-727	002-605
KZ1100L1 LTD	1983	007-727	002-605
ZN1100B1/B2 LTD Shaft	84-85	007-727	002-605

## Kawasaki Dual Sport & Offroad

Model	Year	Float	Float Pin
KX80L1/L2	88-89	018-397	018-670
KX80N1/N2	88-89	018-397	018-670
KX85A1/A2/A3/A4/A5/A6F/A7F/A8F/A9F	01-09	018-397	018-670
KX85AAF/ABF/ACF	10-12	018-397	018-670
KX100D1/D2/D3/D4/D5/D6F/D7F/D8F/D9F	01-09	018-397	018-670
KX100DBF/DCF/DDF	11-13	018-397	018-670
KX125F1/G1/H1/H2/J1/J2	88-93	018-110	018-670
KX125K1/K2	94-95	018-110	018-670
KDX200C3	1988	018-110	018-670
KDX200E1-E11	89-05	018-110	018-670
KDX200H6F	2006	018-110	018-670
KDX220A4-A12	97-05	018-110	018-670
F11/A/B-250	73-75	002-114	002-605
F21M 238 Greenstreak		002-114	002-605
F4-250	69-70	002-114	002-605
KDX250D1/D2/D3/D4	91-95	018-110	018-670
KE250B1/B2/B3	77-79	002-114	002-605
KX250F1/G1/H1/H2/K1/K2	88-95	018-110	018-670
KX250N1/N2/N3 (KX250F)	04-06	018-202	018-670
KX250T6F/T7F/T8F KX250F	07-08	018-202	018-670
KX250W9F/ XAFB KX250F	09-10	018-202	018-670
KX450D6F/D7F/D8F	06-08	018-202	018-670
KX500D1/E1-E7	88-95	018-110	018-670

## Keihin

CR Special 26-39		018-672	018-670
FCR33/35/37/39/41		021-051	018-670
FCR-MX37/39/41		018-202	018-670
PJ34/38		018-110	018-670
PE20/22		018-396	018-670
PE24		018-397	018-670
PE36		018-789	018-670
PE38		018-788	018-670
PWM38		018-202	018-670
PWK28		018-397	018-670
PWK33/35/36/38/41		018-110	018-670

## Mikuni

Model	Year	Float	Float Pin
HSR42/45/48		007-497	002-107
RS34/36/38/40 Radial Slide Smoothbore		007-141	002-605
TM36/TM40		007-141	002-605
TM33		007-606	002-605
VM33 Smoothbore		002-501	002-605
VM29 Smoothbore		002-501	002-107
VM24/26 Roundslide (flange & clamp-on)		002-114	002-107
VM20 Roundslide (flange mount)		002-725	002-107
VM18 Roundslide		007-290	002-107

## Suzuki Street

GS250TT/TX	80-81	007-727	002-605
GS300LZ/LD	82-83	007-727	002-605
GS300LF	1985	007-727	002-605
GT380J/K/L/M/A/B	72-77	002-114	002-605
GS450ED	1983	007-727	002-605
GS450GAZ/GAD Automatic	82-83	007-727	002-605
GS450GAF Automatic	1985	007-727	002-605
GS450LD	1983	007-727	002-605
GS450LF/LG/LH/LJ	85-88	007-727	002-605
GS450TXD	1983	007-727	002-605
GS550ET	1980	007-727	002-605
GS550LT/LX/LZ	80-82	007-727	002-605
GS550MZ	1982	007-727	002-605
GS550TX	1981	007-727	002-605
GT550J/K/L/M/A/B	72-77	002-114	002-605
GR650D/XD Tempter	1983	007-727	002-605
GS650EX/EZ	81-82	007-727	002-605
GS650GX/GZ/GD	81-83	007-727	002-605
GS650GLX/GLZ/GLD	81-83	007-727	002-605
GS650MD Katana	1983	007-727	002-605
GS700EF/ESF	1985	007-727	002-605
GS750ET/EX/EZ	80-82	007-727	002-605
GS750ED/ESD	1983	007-727	002-605
GS750LT/LX	80-81	007-727	002-605
GS750SD Katana	1983	007-727	002-605
GS750TZ/TD	82-83	007-727	002-605
GS850GT/GX/GZ/GD	80-83	007-727	002-605
GS850GLT/GLX/GLZ/GLD	80-83	007-727	002-605
GS1000ET	1980	007-727	002-605
GS1000GT/GX	80-81	007-727	002-605
GS1000GLT/GLX	80-81	007-727	002-605
GS1000ST	1980	007-727	002-605
GS1000SZ Katana	1982	007-727	002-605
GS1100ET/EX/EZ	80-82	007-727	002-605
GS1100ED/ESD	1983	007-727	002-605
GS1100GKZ/GK2/GKD/GKE	82-84	007-727	002-605
GS1100GLZ/GLD	82-83	007-727	002-605
GS1100LT	1980	007-727	002-605
GS1100SD	1983	007-727	002-605
GS1150ES3/ESE/EF/ESF/EF2	83-85	007-727	002-605
GS1150/EG/ESG	1986	007-727	002-605

## Suzuki Offroad

Model	Year	Float	Float Pin
RM125R/S/T/V	94-97	018-110	018-670
RM125X/Y	99-00	018-110	018-670
RM250R/S/T/V/W/X/Y	94-00	018-110	018-670
RM-Z250K4/K5/K6/K7/K8/K9	04-09	018-202	018-670
RM-Z450K5/K6/K7	05-07	018-202	018-670

## Yamaha Street

SR250G/H/J Exciter	80-82	002-114	002-605
SR250TH Exciter II	1981	002-114	002-605
XS400J/K Maxim	82-83	007-727	002-605
XS400RJ/RK Seca	82-83	007-727	002-605
XS500C	1976	002-114	002-605
FJ600L/LC/N/NC	84-85	007-727	002-605
XS1/XS1B/XS2-650	70-72	002-114	002-605
TX650/A	73-74	002-114	002-605
XS650B/C/D/E/F	75-79	002-114	002-605
XS6502F	1979	002-114	002-605
XS650G/H Special II	80-81	007-727	002-605
XS650SE/SF Special	78-79	002-114	002-605
XS650SG/SH Special	80-81	007-727	002-605
XS650SJ/SK Heritage Special	82-83	007-727	002-605
XJ700XN/XNC/XS/XSC Maxim X	85-86	007-727	002-605
<b>007-727 and 002-605 will not fit XJ700N/NC/S/SC (85-86) Maxim applications with Hitachi carbs. Verify carb body identification before ordering.</b>			
TX750/A	73-74	002-114	002-605
XJ900RK Seca	1983	007-727	002-605
FJ1100L/LC/N/NC	84-85	007-727	002-605
XJ1100J Maxim	1982	007-727	002-605
XS1100H	1981	007-727	002-605
XS1100LH Midnight Special	1981	007-727	002-605
XS1100SH Special	1981	007-727	002-605
FJ1200S/SC/T/TC	86-87	007-727	002-605
FJ1200W/WC/A/AC/B/BC/D/DC	89-92	007-727	002-605
FJ1200AD/ADC/AE/AEC	92-93	007-727	002-605

## Yamaha Offroad

WR250FN-FV	01-06	018-202	018-670
WR250FA/FB	11-12	018-202	018-670
YZ250FN-FY	01-09	018-202	018-670
WR400FM	2000	018-202	018-670
WR426FN/FP	01-02	018-202	018-670
YZ426FM/FN/FP	00-02	018-202	018-670
WR450FR/FS/FT/FV/FW/FX/FY	03-09	018-202	018-670
WR450FA	2011	018-202	018-670
YZ450FR/FS/FT/FV	03-06	018-202	018-670
YZ450FSPV	2006	018-202	018-670

# KEIHIN Needle Valve & Needle Valve Sets



018-881



018-882



021-860



021-862



018-880



018-884

## Sudco Keihin Needle Valve Sets

Genuine OEM KEIHIN needle valve w/clip, needle valve seat, filter, o-ring for seat and screw for needle seat. Fits OEM carburetors listed. Sold as a set. **Made in Japan.**

Model applications begin on page 251.

### Husqvarna

Model	Year	OEM Reference	Order No.
SMR630 Replica	2004	8000 98272	<b>018-881</b>

### Kawasaki

KLX400B1 (KLX400R)	1993	16030-S009	<b>018-881</b>
clip for 16030-S009		16030-S010	
ZX600D1-D4 Ninja ZX-6	90-93	16030-1072	<b>018-886</b>
ZX600E1-E10 Ninja ZX-6	93-02	16030-1072	<b>018-886</b>
ZX60E11/E12 ZZR600	03-04	16030-1072	<b>018-886</b>
ZX600F1/F2/F3 Ninja ZX-6R	95-97	16030-1083	<b>018-887</b>
ZX750H1/H2 Ninja ZX-7	89-90	16030-1068	<b>018-887</b>
ZX750J1/J2 Ninja ZX-7	91-92	16030-1068	<b>018-887</b>
ZX750K1/K2 Ninja ZX-7R	91-92	16030-1073	<b>018-887</b>
ZX750L1/L2/L3 Ninja ZX-7	93-95	16030-1068	<b>018-887</b>
ZX750M1/M2 Ninja ZX-7R	93-94	16030-1073	<b>018-887</b>
ZX900C1/C2 Ninja ZX-9R	98-99	16030-1077	<b>018-886</b>
ZX900F1/F2 Ninja ZX-9R	02-03	16030-1077	<b>018-886</b>
ZX1000B1/B2/B3 Ninja ZX-10	88-90	16030-1068	<b>018-887</b>
ZX1100C1-C4 Ninja ZX-11	90-93	16030-1069	<b>018-886</b>
ZX1100D1-D9 Ninja ZX-11	93-01	16030-1077	<b>018-886</b>
ZX1200C1-C4 ZZR1200	02-05	16030-1077	<b>018-886</b>

### Suzuki

DR-Z400EY-EK7	00-07	13371-29F00	<b>018-881</b>
DR-Z400Y/K1-K6	00-06	13371-29F00	<b>018-881</b>

When ordering for DRZ400, check that carburetor is Keihin FCR.

### Yamaha

WR250FN/FP	01-02	5BE-14107-00-00	<b>018-881</b>
YZ250FN/FP	01-02	5BE-14107-00-00	<b>018-881</b>
WR400FK/FL/FM	98-00	5BE-14107-00-00	<b>018-881</b>
YZ400FK/FL	98-99	5BE-14107-00-00	<b>018-881</b>
WR426FN/FP	01-02	5BE-14107-00-00	<b>018-881</b>
YZ426FM/FN/FP	00-02	5BE-14107-00-00	<b>018-881</b>
YZF600R	95-07	4JH-14107-00-00	<b>018-882</b>



## Sudco Keihin Needle Valves

Genuine OEM KEIHIN Needle Valves, with clip. Available for Keihin Aftermarket (genuine) and Keihin OEM (genuine) carburetors. Sold each. **Made in Japan.**

Model applications begin on page 251.

### Honda

Model	Year	OEM Reference	Order No.
CR85R/RB	05-08	16011-KBA-850	<b>018-885</b>
CR250R	84-98	16011-HA2-671	<b>018-883</b>
CRF250R	04-05	16011-KZ3-J11	<b>018-884</b>
CRF450R	02-05	16011-KZ3-J11	<b>018-884</b>
CRF250R/CRF450R	06-09	16011-MEN-851	<b>018-884</b>
CRF250X/CRF450X	07-09	16011-MEN-851	<b>018-884</b>
		16011-382-004	<b>018-880</b>
CBR600F2/F3/F4 Hurricane	91-00	16155-MN9-004	<b>021-860**</b>
		16155-397-971	<b>021-861</b>
		16155-413-751	<b>021-862</b>

\*\* Keyster (Not OEM)

### Husqvarna

TE610 FCR-MX Carbs	2006	8000 A5629	<b>018-884</b>
--------------------	------	------------	----------------

### Kawasaki

EX500 with CVK	87-09	16030-1007	<b>018-880</b>
PWK & FCR-MX		16030-1057	<b>018-884</b>
VN750 Vulcan with CVK	86-87	16030-1057	<b>018-884</b>
ZRX1200	(all)	16030-1057	<b>018-884</b>
KX85/KX100 with PWK28	01-09	16030-1064	<b>018-885</b>

### KTM

Keihin PWK & FCR-MX	5461020000	<b>018-884</b>
Keihin PWK28		<b>018-885</b>

### Suzuki

RM85	02-09	13370-03B00	<b>018-885</b>
GSF600 Bandit with CVK		13370-26E00	<b>018-880</b>
RM250 with PJ Carb	93-96	13370-28E00	<b>018-883</b>
RM-Z250 with FCR-MX	07-09	13370-29F00	<b>018-884</b>
RM-Z450 with FCR-MX	05-07	13370-29F00	<b>018-884</b>
RM125 with PWK Carb		13370-43D30	<b>018-884</b>
RM-Z250 with FCR-MX	04-06	K1603-01057	<b>018-884</b>
RM100 with PWK28	2003	K1603-01064	<b>018-885</b>

### Triumph

CVK Carburetor	T1241033	<b>018-884</b>
----------------	----------	----------------

### Yamaha

PWK/PWM & FCR-MX Carbs	4MX-14392-00-00	<b>018-884</b>
PWK28, YZ85	03-13 5PA-14392-00-00	<b>018-885</b>

Photo courtesy of Sunstar Sprockets



007-953, 007-954



007-959



007-960



007-955



007-957

## Sudco Mikuni Needle Valve Assemblies

Genuine OEM "MIKUNI" replacement needle valve assemblies.

**Made in Japan.** Order by Sudco part number.

**Model applications begin on page 251.**

### Honda

Model/Application	Year	Size	OEM Reference	Order No.
CR125R	02-07	3.8	16011-KZ4-A92	002-877
CR250R	01-07	3.8	16011-KZ4-A92	002-877

### Kawasaki

H1-500/H2-750	(all)	2.5	16030-005	007-955
KZ750 2-cyl.	76-80	2.0	16030-026	007-976
KZ900/1000	76-80	2.3	16030-027	007-966
KZ650	77-80	2.0	16030-1001	007-958
KZ1000/1100	81-85	2.5	16030-1016	007-956
KX125	82-87	3.3	16030-1020	007-959
KXT250A/B Tecate	84-87	3.3	16030-1020	007-959
KLF220ABayou 220	88-02	1.5	16030-1066	007-967
KX125	01-05	3.8	16030-1096	002-877

### Polaris

ATV (screw-in type) Assy.		2.5	3130360	007-964
			3130047-washer	002-188

### Suzuki

RM60K3/K4	03-04	2.5	KK160-30005	007-955
DR350S Dual Sport	90-99	1.5	13370-02D00	007-971
GS500E	89-00	1.5	13370-02D00	007-971
LT-4WDL 4x4	90-96	1.5	13370-05320	007-967
DR-Z250K Offroad	01-07	1.8	13370-05530	007-502
(49 State model, E3-E28)				
see 13370-44500		2.0	13370-11400	007-957
see 13370-43B00		3.3	13370-14300	007-959
see 13370-41500		2.5	13370-18010	---
GS550	77-79	2.3	13370-18111	007-966
GS1000	77-78	2.3	13370-18111	007-966
see 13370-05320		1.5	13370-19B00	007-967
LS650	88-06	2.5	13370-24C80	007-970
RM125/RM250	89-92	3.5	13370-26C00	002-466
see 13370-41500		2.5	13370-32210	---
RM125	00-07	3.3	13370-36F00	007-954
see 13370-24C80		2.5	13370-37400	007-970
GT750 Lemans	72-73	2.5	13370-41500	---
LT250R/LT500R Quadracer		3.3	13370-43B00	007-959
see 13370-05320		1.5	13370-43250	007-967
see 13370-48B00		2.8	13370-43410	---
see 13370-02D00		1.5	13370-44B00	007-971
GS750E	80-82	2.0	13370-44500	007-957
GS850G	80-83	2.0	13370-44500	007-957

## Suzuki

Model/Application	Year	Size	OEM Reference	Order No.
see 13370-18111		2.3	13370-45010	007-966
GT380	72-73	2.0	13370-48051	007-958
see 13370-46E20			13370-46E00	007-972
see 13370-46E20			13370-46E10	007-972
GSX-R1100	93-98		13370-46E20	007-972
GS550LF/LG	85-86	2.8	13370-48B00	---
GSX1100F Katana		2.8	13370-48B00	---
GT750 Lemans	74-77	2.0	13372-31210	007-976

## Yamaha

XS750/XS1100	77-79	2.0	1J7-14190-20-00	007-976
YFZ350 Banshee	87-06	2.8	1UA-14190-28-00	007-978
YFM350X Warrior	87-04	2.5	1UY-14107-25-00	007-977
XS400 Maxim & Seca		2.0	11H-14107-20-00	007-957
XS650	72-79	2.0	168-14190-20-00	007-958
XS1B-650	1971	2.5	168-14190-25-00	007-955
see 23L-14107-25-00		2.5	168-14190-25-00	007-955
DT250		2.8	168-14190-28-00	007-963
YFS200 Blaster	88-06	2.8	2MA-14107-28-00	007-979
RD250, RD350, RD400	73-78	2.5	23L-14107-25-00	007-955
IT465H, YZ465		3.5	23X-14107-35-00	007-960
IT490, YZ490, WR500Z	82-93	3.5	23X-14107-35-00	007-960
IT250G/H/J/K	80-83	3.0	24X-14107-30-00	007-962
YZ125	77-88	3.3	24X-14107-33-00	007-961
YZ250	74-77	3.3	24X-14107-33-00	007-961
FJ600L/LC/N/NC	84-85	2.0	25G-14107-20-00	007-503
FJ1100	84-85	2.3	25G-14107-23-00	007-504
FJ1200	86-87	2.3	25G-14107-23-00	007-504
FJ1200	89-93	1.5	3CF-14107-15-00	007-980
YZ125/YZ250	89-94	3.5	3JD-14107-35-00	002-466
YZ125	95-08	3.8	4PE-14107-38-00	002-877



## Genuine Mikuni Needle Valve Seat Filter

Used on the following Mikuni carburetors: RS34, RS36, RS38 & RS40 Smoothbore, VM29, VM33 Smoothbore, TM33 Pumper and OEM push type needle valve assembly. Sold each. Needle Valve Assembly not included. **Made in Japan.**

Order No. **002-606**

### OEM reference for Needle Valve Seat Filter

Kawasaki 14043-1010	Late model KZ1000/1100
Suzuki 13376-19F00	GS series - GS750/1000/1100
Yamaha 1J7-14994-00-00	XS1100 Series

# Sudco Float Bowl O-Rings



007-508

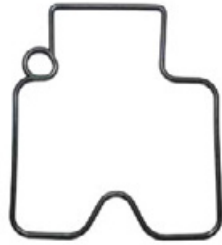

021-055



021-875



021-876

## Sudco Float Bowl O-Rings

OEM (genuine) replacements. Sold each. *Made in Japan.*

**Model applications begin on page 251.**

### Arctic Cat

Model	Year	OEM Reference	Order No.
DVX400	04-07	4505-111	<b>007-756</b>
DVX400 Sport (Tony Stewart)	2007	4505-111	<b>007-756</b>

### Honda

XL250	72-76	16010-329-305	<b>021-889</b>
CB750C/F/K/SC	79-83	16010-425-305	<b>021-883</b>
GL1100 Goldwing	80-83	16010-463-004	<b>021-883</b>
CB550SC Nighthawk		16010-MA6-305	<b>021-880</b>
CB700SC Nighthawk		16010-MA6-305	<b>021-880</b>
TRX90 Fourtrax & Sportrax	(all)	16163-GBG-960	<b>021-884</b>
TRX400EX Fourtrax & Sportrax	(all)	16163-HM7-700	<b>021-882</b>
VT600C Shadow (after 1999)		16163-HM7-700	<b>021-882</b>
CR85R/RB	05-07	16163-KBA-850	<b>018-406</b>
CB750K	77-78	16163-KCS-920	<b>021-886</b>
GL1500C Valkyrie	97-03	16163-KEA-000	<b>021-874</b>
CR250R	97-98	16163-KZ3-B10	<b>021-872</b>
CR125R	00-01	16163-KZ4-A92	_____
CR250R	01-03	16163-KZ4-A92	_____
CR125R	84-99	16163-KZ4-J01	<b>018-113</b>
CR250R	81-96	16163-KZ4-J01	<b>018-113</b>
CR500R	84-01	16163-KZ4-J01	<b>018-113</b>
CR125R	02-07	16163-KZ4-L22	<b>007-753</b>
CR250R	04-07	16163-KZ4-L22	<b>007-753</b>
VT1100 Shadow		16163-MAH-750	<b>021-885</b>
GL1500 Goldwing		16163-MAH-750	<b>021-885</b>
VTR1000F Superhawk	98-03	16163-MBB-640	<b>021-873</b>
CRF150R	07-08	16163-MEB-671	<b>021-731</b>
CRF150RB	2008	16163-MEB-671	<b>021-731</b>
CRF250R/X	all	16163-MEB-671	<b>021-731</b>
CRF450R/X	all	16163-MEB-671	<b>021-731</b>
CBR600F2/F3/F4 Hurricane	91-00	16163-MZ5-920	<b>021-871</b>
CBR900RR	93-99	16163-MZ5-920	<b>021-871</b>

### Husqvarna

CR125/WR125 with TMX Carb	_____
CR250/WR250 with TMX Carb	_____
TE250 with FCR-MX Carb	<b>021-731</b>
TE450 with FCR-MX Carb	8000 A5632 <b>021-731</b>
SMR630 with FCR41 Carb	<b>021-055</b>

### Keihin

CR Special 29/31/33/35/37/39mm	0901-811-6000	<b>018-668</b>
FCR-37/39/41mm	1202-846-6000	<b>021-055</b>
FCR-MX37/39/41mm	1202-896-6000	<b>021-731</b>
PE20 - 24	W1354-042-9900	<b>018-406</b>
PWK28mm	W1354-042-9900	<b>018-406</b>
PJ/PWK35/36/38/39	16163-ND4-7510-M	<b>018-113</b>
PWM38	16163-ND4-7510-M	<b>018-113</b>

## Kawasaki

Model	Year	OEM Reference	Order No.
KX80	88-00	92055-1389	<b>018-406</b>
KX85/KX100	01-13	92055-1389	<b>018-406</b>
KLX110A1-CCF	02-12	11060-170	<b>021-884</b>
KX125/250	88-97	11009-1716	<b>018-113</b>
KX125	03-05	92055-0001	<b>007-753</b>
KDX200	88-06	11009-1716	<b>018-113</b>
KL250G Super Sherpa	00-03	92055-1575	<b>021-875</b>
KX250	98-07	11060-1254	<b>021-872</b>
KX250N1/N2 (KX250F)	04-05	92055-0066	<b>021-731</b>
KX250T6F/T7F/T8F (KX250F)	06-08	92055-0066	<b>021-731</b>
KLX400A1 Dual Sport	2003	92055-S058	<b>007-756</b>
KLX400B1 w/FCR39H Carb	2003	11061-S092	<b>021-055</b>
KSF400A1-A6F (ATV)	03-06	92055-S058	<b>007-756</b>
KX450D6F/D7F/D8F (KX450F)	06-08	92055-0066	<b>021-731</b>
EX500A1-D9F	87-09	92055-1222	<b>021-887</b>
ZX600F Ninja ZX-6R	95-97	92055-1426	<b>021-888</b>
KZ750E/H/N	80-83	16019-024	<b>021-889</b>
ZX750H/J/L ZX7	89-95	92055-1426	<b>021-888</b>
ZX750K1-M2 Ninja ZX-7R	92-94	11061-S092	<b>021-055</b>
ZX750P1-P8 Ninja ZX-7R	96-03	92055-1426	<b>021-888</b>

## KTM

Models with standard PWK Carb	54531610000	<b>018-113</b>
Non Air Striker, no hole on o-ring		
Models with PWK AG Carb	54831010000	<b>021-872</b>
Quad Vent/Air Striker with hole on o-ring		
Models with FCR-MX Carb	FCR-MX	<b>021-731</b>

## Mikuni

HSR42/HSR45/HSR48	616-94028	<b>007-472</b>
RS34/RS36/RS38/RS40 (1, 3, & 4)	616-94020	<b>007-140</b>
RS34/RS36/RS38/RS40 (2)	616-94021	<b>007-197</b>
TM33-8012	619-94012	<b>007-508</b>
TM36/TM40	616-94021	<b>007-197</b>
TMS38	TMX38-252	<b>002-484</b>
TMX35-1	TMX38-252	<b>002-484</b>
TMX38-2, TMX-38-5	616-93054	<b>007-753</b>
TMX38-1	616-93036	_____
TMX38-18, TMX38-27	TMX38-252	<b>002-484</b>

## Suzuki

RM85	02-12	13251-03B00	<b>018-406</b>
RM100K3	2003	K9205-51389	<b>018-406</b>
DR-Z110K3/K4/K5	03-05	K1106-01700	<b>021-884</b>
RM125K1-K7	01-08	13251-36F00	<b>007-753</b>
RM125R/S/T/V/W	94-98	13696-28E00	<b>018-113</b>
DR250 Offroad w/TM33	90-93	13251-27A00	<b>007-508</b>
DR-Z250	01-07	13258-04F00	<b>007-756</b>
DR-Z250K Offroad w/TM33	01-07	13251-27A00	<b>007-508</b>
GZ250 X-K9	99-10	13258-04F00	<b>007-756</b>
LT-F250	99-01	13258-04F00	<b>007-756</b>
LT-F250F	99-02	13258-04F00	<b>007-756</b>
LT-Z250 K4-K9	04-09	13258-04F00	<b>007-756</b>
RM250P/R/S/T/V	93-97	13696-28E00	<b>018-113</b>
RM250W/X/Y/K1-K8	98-08	13696-44E00	<b>021-872</b>

# Sudco Float Bowl O-Rings & Top Cover O-Rings



018-406

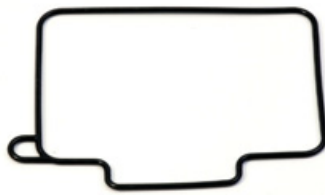

007-753

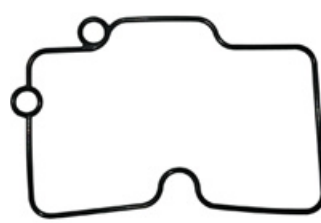

021-731



007-756

## Suzuki

Model	Year	OEM Reference	Order No.
RM-Z250K4/K5/K6	04-06	K9205-50066	021-731
RM-Z250K7/K8	07-08	13251-35G00	021-731
LT-F300F	00-02	13258-04F00	007-756
DR350 Offroad w/TM33	90-99	13251-27A00	007-508
DR-Z400S	01-09	13258-04F00	007-756
DR-Z400SL1	2011	13258-04F00	007-756
DR-Z400SM	05-08	13258-04F00	007-756
DR-Z400 SMK5/SMK7 Supermotard	05-07	13258-04F00	007-756
DR-Z400 SY-SK7 Dual Sport	01-07	13258-04F00	007-756
DR-Z400 w/FCR39-H Carb	00-07	13251-29F00	021-055
LT-Z400K3-K8 QuadSport	03-08	13258-04F00	007-756
RM-Z450K5/K6/K7/K8	05-08	13251-35G00	021-731
GS500F	04-09	13258-04F00	007-756
GS500 FK4-FK7	04-07	13258-04F00	007-756
GSF600S Bandit	96-03	13258-26E00	021-887
GSX600F Katana	99-06	13258-04F00	007-756
GSX600 FW-FK6	98-06	13258-04F00	007-756
SV650	99-02	13258-33E00	021-877
GSX-R600	97-00	13258-33E00	021-877
GSX750 FW-FK6	98-06	13258-04F00	007-756
GSX-R750	85-86	13251-42A00	021-875
GSX-R750	88-95	13258-44B00	021-876
GSX-R750	96-99	13258-33E00	021-877
VL800	01-05	13258-33E00	021-877
GSF1200 SK1-SK5 Bandit	01-05	13258-04F00	007-756
GSF1200S	01-05	13258-04F00	007-756
VL1500	98-04	13258-33E00	021-877

## Triumph

Models with Keihin CVK Carburetors	T1241036	021-887
Models with Mikuni CV Carburetors	1240060	021-876

## Yamaha

YZ85	93-11	5PA-14984-00-00	018-406
YZ125	99-09	5ET-1416A-00-00	007-753
WR250F	01-11	5JG-14984-00-00	021-731
YFM250	05-07	5DM-14561-00-00	007-756
YZ250	95-98	4MX-14984-00-00	018-113
YZ250	99-13	4JT-14984-00-00	021-872
YZ250F	03-12	5JG-14984-00-00	021-731
YFM350	96-07	2LN-14147-00-00	021-875
WR400FK/FL	98-99	3TJ-14984-40-00	021-055
YFM400	01-04	5DM-14561-00-00	007-756
YZ400FK/FL	98-99	3TJ-14984-40-00	021-055
WR426F	01-02	5JG-14984-00-00	021-731
YZ426F	00-02	5JG-14984-00-00	021-731
WR450	03-11	5JG-14984-00-00	021-731
YFM450	03-04	5DM-14561-00-00	007-756
YFZ450	04-08	5JG-14984-00-00	021-731
YXR450 Rhino 450 4WD	2006	5DM-14561-00-00	007-756
YZ450F	03-09	5JG-14984-00-00	021-731
TX500/A	73-74	93210-67232-00-00	021-889
XS500B	1975	93210-67232-00-00	021-889
FZR600	89-99	3GM-14997-00-00	_____

## Yamaha

Model	Year	OEM Reference	Order No.
YFM600 Grizzly	98-01	4WV-14147-20-00	021-876
YFM660 Grizzly	02-06	5DM-14561-00-00	007-756
YFM660 Raptor	01-05	5DM-14561-00-00	007-756
YXR660 Rhino	04-07	5DM-14561-00-00	007-756
YZF600R	95-07	4JH-14984-00-00	021-888
VMX12 V-Max	86-07	22V-14147-00-00	_____
XV1600	99-03	5DM14561-00-00	007-756
XV1700	04-06	5DM-14561-00-00	007-756
YZF-R1	99-01	4XV-14562-00-00	021-877



007-755



007-754

## Sudco TMX Top Cover O-Rings

Replacement top cover O-Rings for OEM TMX carburetor. **Made in Japan.** Sold each.

See page 190-191 for Mikuni TMX replacement parts.

## Honda

Model	Year	OEM Reference	Order No.
CR125R	00-01	_____	007-755
CR125R	02-03	_____	007-754
CR250R	01-03	_____	007-755

## Husqvarna

CR125/WR125 w/TMX	_____	007-755
CR250/WR250 w/TMX	_____	007-755

## Kawasaki

KX125L3/L4	01-02	_____	007-755
KX125M1/M2/M3	03-05	_____	007-754

## Suzuki

RM125K1/K2/K3/K4	01-04	13258-36F00	007-754
------------------	-------	-------------	---------

## Yamaha

YZ125G/H1/J1/K1	95-98	4PE-14147-00	007-755
YZ125L/M/N/P/R	99-03	5ET-14147-00	007-754
YZ125S1/T1/V/W1/X1	04-08	5ET-14147-00	007-754
YZ125Y/Z/A1/B1/D2	09-13	5ET-14147-00	007-754



# Sudco Float Bowl Gaskets



021-895



002-607



007-990

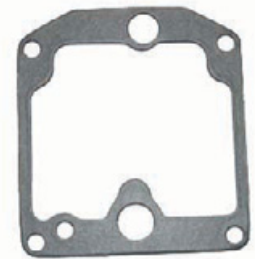

007-994

## Sudco Float Bowl Gaskets

OEM (genuine) replacements. Sold each. *Made in Japan.*  
Model applications begin on page 251.

### Honda

Model	Year	OEM Reference	Order No.
CT70	1978	16010-102-305	021-896
CT90	69-77	16010-102-305	021-896
CB750	69-76	16129-268-004	021-895

### Kawasaki

KLT200A1/A2	81-82	11009-1028	021-895
KX125	78-81	11009-1079	002-101
KX60	83-03	11009-1147	007-250
KX65	all	11009-1147	007-250
KLX250A	79-80	11009-1156	007-996
KX80	80-87	11009-1178	007-251
KL250A	80-82	11009-1184	007-991
see 11060-1607		11009-1241	007-990
KD80N	88-90	11009-1250	007-282
KX125	82-87	11009-1275	002-700
KZ650, KZ1000	79-80	11009-1562	007-997
KZ650, KZ1000	77-78	11009-1563	007-994
KLF220/KLF250		11009-1676	007-999
KZ1000J/K/M/R	81-83	11060-1607	007-990
H1-500	69-75	16019-008	002-099
H2-750	72-75	16019-008	002-099
S2/S2A-350 <b>NEW</b>	72-73	16019-013	007-987
S3/S3A-400 <b>NEW</b>	74-75	16019-013	007-987
KH400A <b>NEW</b>	76-78	16019-013	007-987
Z1-900 frame 00001 to 32817	73-74	16019-019	007-992
S1/S1A/S1B-250/KH250 <b>NEW</b>	73-76	16019-021	007-988
Z1-900 from frame 32818 on	74-75	16019-025	007-993
KX250	78-82	16019-028	002-102
KZ750B1-B4 2-cylinder	76-79	16019-029	007-989

### Mikuni

VM29 Smoothbore	VM26/258	002-502
VM33 Smoothbore	VM30/257	002-607
TM24, 20mm flange	VM20/492	007-250
TM28	VM26/228	007-251
TM32, TM34, TM36, TM38	VM34/374	002-700
VM18	VM17/161	007-283
22/26 - 34mm flange	VM30/103	002-099
28mm spigot	VM28/129	002-361
30 small body	VM30/172	002-103
30 - 34mm spigot (without baffle plate)	VM34/30	002-100
30 - 34mm spigot (with baffle plate)	VM34/71	002-101
36 - 44mm spigot	VM36/20	002-102

## Polaris

Model	Year	OEM Reference	Order No.
Mikuni VM Zinc Carburetors		3130020	002-099

## Suzuki

GT250K Hustler	73-77	13251-11010	002-009
LT500RQuad racer	all	13251-14300	002-700
DS80	83-00	13251-03410	007-282
see 13251-03410		13251-23011	007-282
see 13251-03410		13251-23010	007-282
RM80	86-89	13251-29630	007-251
GT750K/L/M/A Lemans <b>NEW</b>	73-77	13251-31210	007-989
DR250	82-85	13251-32410	007-996
DR370/DR400		13251-32410	007-996
GT380	73-77	13251-33110	002-099
GN250, LS650 Savage		13251-38300	007-991
RM250	76-80	13251-40600	002-102
GS550/750	77-79	13251-43010	007-994
GS850	80-83	13251-44080-H17	007-990
GS1150		13251-44080-H17	007-990
see 13251-44080-H17		13251-44080	007-990
see 13251-43010		13251-47010	007-994
RM250	88-92	13696-26C00	002-484
RM60	03-05	K1100-91147	007-250

## Yamaha

XV1000	84-85	10L-14984-01-00	026-324
XJ650L Seca Turbo		16G-14147-00-00	---
AT1-125MX	69-73	156-14184-00-00	002-009
YCS1/YCS1C	1968	164-14184-00-00	007-282
XR750/1100	78-79	2A2-14984-01-00	007-991
SR500E/F	78-79	2H0-14184-00-00	007-996
YFB250 Timberwolf	92-00	24W-14184-00-00	007-999
XS650/TX650 <b>NEW</b>	70-78	256-14984-01-00	007-989
R5-350	70-72	278-14184-00-00	002-361
XS1100	80-81	3F7-14984-00-00	007-990
YZ125/250	89-94	3JE-14147-00-00	002-484
XS850	80-81	3J3-14984-00-00	026-326
FJ1100/FJ1200	all	3XW-14984-00-00	---
YFZ350 Banshee	all	304-14184-00-00	007-250
YZ250/YZ360	1974	310-14184-00-00	002-101
RD250/350/400		360-14184-01-00	007-995
YZ400	76-79	363-14184-00-00	002-102
XJ550 Maxim & Seca	81-83	46X-14984-00-00	007-998
see 46X-14984-00-00		4G0-14984-00-00	007-998
XJ650/XJ750	80-83	4H7-14984-01-00	026-320
XV750	81-83	4X7-14984-01-00	026-322
XV920	1982	4X7-14984-01-00	026-322
YZ100	77-83	537-14184-00-00	002-103



# Needle Valve Sets, Needle Valves, Gaskets & O-Rings

## Honda Street

Model	Year	Needle Valve Assy	Needle Valve	Float Bowl Gasket/O-Ring
C70 Passport	80-83	—	—	021-884
CT70H/HK1 Trail 70H	70-73	—	—	021-896
CT70K1/K2/K3/K4 Trail 70	72-75	—	—	021-896
CT70 Trail 70	76-77	—	—	021-896
CT70 Trail 70	80-82	—	—	021-884
CT70	91-94	—	—	021-884
CT90K1/K2/K3/K4 Trail 90	69-73	—	—	021-896
CT90K5/K6 Trail 90	74-75	—	—	021-896
CT90 Trail 90	76-77	—	—	021-896
CT90 Trail 90	78-79	—	—	021-884
ST90/K1/K2 TrailSport 90	73-75	—	—	021-896
XL100	77-78	—	018-880	021-886
XL100S	79-85	—	018-880	021-886
CB125S	78-82	—	018-880	021-886
CB125S	84-85	—	021-861	021-886
CB125TT	1990	—	021-862	—
CH125	1984	—	021-862	—
CH150	1985	—	021-861	021-886
CH150D	1985	—	021-861	021-886
CT125 Trail 125	1977	—	—	—
MT125R	1978	—	018-883	018-113
NSF100	2006	—	—	021-886
NX125	88-90	—	021-862	021-886
SL125/K1/K2 Motosport 125	71-73	—	—	—
XL125/K1	74-75	—	—	—
XL125 Carb ID 065C	1976	—	—	—
XL125 Carb ID PD65A	1976	—	018-880	021-886
XL125	77-78	—	018-880	021-886
XL125S	79-82	—	018-880	021-886
XL125S	84-85	—	018-880	021-886
CA175K3 Touring 175	1970	—	—	—
CB175K3 Super Sport	1969	—	—	—
CB175K4-K7 Super Sport 175	70-73	—	—	—
CL175K3 Scrambler 175	1970	—	—	—
CL175K4-K7 Scrambler 175	70-73	—	—	—
SL175K/K1 Motosport 175	70-72	—	—	—
CM185T Twinstar	78-79	—	018-880	021-886
XL185S	79-82	—	018-880	021-886
XL185S	1983	—	021-861	—
CB200K	1974	—	—	—
CB200T	75-76	—	—	—
CL200 Scrambler	1974	—	—	—
CM200T Twinstar	80-82	—	018-880	021-886
XL200R	83-84	—	021-861	021-886
CRF230L Dual Sport	08-09	—	—	021-880
CRF230M	2009	—	—	021-880
CB72 Hawk 250	61-66	—	—	021-895
CL72 Scrambler 250	62-65	—	—	021-895
CB250 Nighthawk 250	91-97	—	021-861	021-882
CB250 Nighthawk 250	99-06	—	021-861	021-882
CH250	1985	—	021-862	—
CH250	1990	—	021-862	—
CM250C	82-83	—	021-862	021-883
CMX250C Rebel	85-87	—	021-861	—
CMX250CD Rebel 250 Limited	1986	—	021-861	—
CMX250C Rebel	96-06	—	021-861	021-882
CMX250C2	99-00	—	021-861	021-882
NSS250	03-06	—	021-862	—
NSS250A	03-06	—	021-862	—
NSS250AS	04-06	—	021-862	—
NSS250S	04-06	—	021-862	—
NX250	88-90	—	021-862	—
PS250	05-06	—	021-862	—
XL250K/K1/K2 Motosport	72-75	—	—	021-889
XL250	1976	—	—	021-889
XL250S	78-81	—	018-880	021-886
XL250R	82-83	—	021-861	021-886
XL250R	84-87	—	018-880	021-886
XR250L	91-96	—	021-862	021-886
CB77 Super Hawk 305	61-68	—	—	021-895
XL350	76-78	—	018-880	—
XL350R	84-85	—	018-880	—

## Honda Street

Model	Year	Needle Valve Assy	Needle Valve	Float Bowl Gasket/O-Ring
CB400A Automatic	1978	—	018-880	021-883
CB400F Super Sport (4 cyl)	75-77	—	—	—
CB400T1 Hawk	78-79	—	018-880	021-883
CB400T11 Hawk	78-79	—	018-880	021-883
CB400T Hawk	80-81	—	021-862	021-883
CM400A Automatic	1979	—	018-880	021-883
CM400A Automatic	80-81	—	021-862	021-883
CM400C Custom	1981	—	021-862	021-883
CM400E	80-81	—	021-862	021-883
CM400T	1979	—	018-880	021-883
CM400T	80-81	—	021-862	021-883
CB450SC Nighthawk	82-83	—	021-862	021-883
CB450SC Nighthawk	1985	—	021-862	021-883
CB450SC Nighthawk	1986	—	021-861	021-883
CB450T Hawk	1982	—	021-862	021-883
CM450A Automatic	82-83	—	021-862	021-883
CM450C Custom	1982	—	021-862	021-883
CM450E	82-83	—	021-862	021-883
CMX450C	86-87	—	021-861	—
CB500/K1/K2 (4 cyl)	71-73	—	—	—
CX500	78-79	—	018-880	021-883
CX500C Custom	1979	—	018-880	021-883
CX500C Custom	80-82	—	021-862	021-883
CX500D Deluxe	1979	—	018-880	021-883
CX500D Deluxe	80-82	—	021-862	021-883
FT500 Ascot	82-83	—	021-861	021-883
GB500	89-90	—	021-862	021-880
GL500 Silverwing	81-82	—	021-862	021-883
GL500I Silverwing Interstate	81-82	—	021-862	021-883
VF500C Magna	84-85	—	018-880	—
VF500F Interceptor	84-85	—	018-880	—
XL500S	79-81	—	018-880	021-886
XL500R	1982	—	021-861	021-886
CB550F Super Sport	75-77	—	—	—
CB550K/K1	74-75	—	—	—
CB550	1976	—	—	—
CB550K	77-78	—	018-880	—
CB550SC Nighthawk	1983	—	021-862	021-880
CB600F	2004	—	—	021-871
CB600F	2006	—	—	021-871
CBR600F2 Hurricane	91-94	—	021-860	021-871
CBR600F3 Hurricane	95-98	—	021-862	021-871
CBR600F4 Hurricane	99-00	—	021-862	021-871
CBR600SE	1998	—	021-862	021-871
CBR600SJR Replica	1996	—	021-862	—
VT600C Shadow	88-89	—	018-880	021-885
VT600C Shadow	91-97	—	018-880	021-885
VT600C Shadow	99-03	—	021-860	021-882
VT600CD Shadow VLX	93-98	—	018-880	021-885
VT600CD Shadow VLX Deluxe	99-03	—	021-860	021-882
VT600CD2 Shadow VLX Deluxe	99-00	—	021-860	021-882
XL600R	83-87	—	018-880	—
CB650	79-80	—	018-880	—
CB650	81-82	—	021-862	021-883
CB650C Custom	1980	—	018-880	—
CB650C Custom	81-82	—	021-862	021-883
CB650SC Nighthawk	1982	—	021-862	021-883
CB650SC Nighthawk	83-85	—	021-862	021-880
CX650C Custom	1983	—	021-862	021-883
GL650 Silverwing	1983	—	021-862	021-883
GL650I Silverwing Interstate	1983	—	021-862	021-883
NT650 Hawk GT	88-91	—	018-880	021-885
NX650	88-89	—	021-860	—
XR650L Dual Sport	93-09	—	021-860	—
CB700SC Nighthawk	84-85	—	021-862	021-880
CB700SC Nighthawk	1986	—	018-880	021-880
VF700C Magna	84-86	—	018-880	021-885
VT700C Shadow	86-87	—	018-880	021-885
CB750 Nighthawk 750	91-93	—	021-862	021-880
CB750 Nighthawk 750	95-03	—	021-862	021-880

VINTAGE  
INTAKE  
ENGINE  
SUSPENSION  
CONTROL  
ELECTRICAL  
CHEMICAL  
TOOLS  
WATERCRAFT



# Needle Valve Sets, Needle Valves, Gaskets & O-Rings

## Honda ATV

Model	Year	Needle Valve Assy	Needle Valve	Float Bowl Gasket/O-Ring
TRX450S Fourtrax Foreman S	98-01	_____	<b>021-861</b>	<b>021-882</b>
TRX500FA Foreman Rubicon	01-03	_____	_____	<b>021-882</b>

## Honda Dual Sport & Offroad

CRF50F	04-09	_____	_____	_____
CRF50F	11-12	_____	_____	_____
XR50R	00-03	_____	_____	_____
Z50A Mini Trail 50	76-78	_____	_____	_____
Z50R	79-89	_____	_____	_____
Z50R	91-99	_____	_____	_____
Z50RD	1986	_____	_____	_____
ZB50	1988	_____	_____	<b>021-884</b>
CR60R	1983	_____	<b>018-885</b>	_____
CRF70F	04-09	_____	_____	<b>021-884</b>
CRF70F	11-12	_____	_____	<b>021-884</b>
CT70H/HK1 Trail 70H	70-73	_____	_____	<b>021-896</b>
CT70K1/K2/K3/K4 Trail 70	72-75	_____	_____	<b>021-896</b>
CT70 Trail 70	76-77	_____	_____	<b>021-896</b>
CT70 Trail 70	78-79	_____	_____	_____
CT70 Trail 70	80-82	_____	_____	<b>021-884</b>
CT70	91-94	_____	_____	<b>021-884</b>
XR70R	97-03	_____	_____	<b>021-884</b>
XL75	77-79	_____	_____	_____
XR75/K1/K2	73-75	_____	_____	_____
XR75	76-78	_____	_____	_____
CR80R	80-95	_____	<b>018-885</b>	_____
CR80R	96-02	_____	<b>018-885</b>	<b>018-406</b>
CR80RB Expert	96-02	_____	<b>018-885</b>	<b>018-406</b>
CRF80F	04-09	_____	_____	_____
CRF80F	11-12	_____	_____	_____
XL80S	80-85	_____	_____	_____
XR80	79-84	_____	_____	_____
XR80R	85-86	_____	_____	_____
XR80R	87-88	_____	_____	_____
XR80R	90-91	_____	_____	_____
XR80R	93-03	_____	_____	_____
CR85R	03-07	_____	<b>018-885</b>	<b>018-406</b>
CR85RB Expert	03-07	_____	<b>018-885</b>	<b>018-406</b>
CT90K1/K2/K3/K4 Trail 90	69-73	_____	_____	<b>021-896</b>
CT90K5/K6 Trail 90	74-75	_____	_____	<b>021-896</b>
CT90 Trail 90	76-77	_____	_____	<b>021-896</b>
CT90 Trail 90	78-79	_____	_____	<b>021-883</b>
ST90/K1/K2 TrailSport 90	73-75	_____	_____	<b>021-896</b>
CRF100F	04-09	_____	<b>018-880</b>	<b>021-886</b>
SL100/K1/K2/K3 Motosport 100	70-73	_____	_____	_____
XL100/K1	74-75	_____	_____	_____
XL100	1976	_____	_____	_____
XL100	77-78	_____	<b>018-880</b>	<b>021-886</b>
XL100S	79-85	_____	<b>018-880</b>	<b>021-886</b>
XR100	81-84	_____	<b>018-880</b>	<b>021-886</b>
XR100R	85-97	_____	<b>018-880</b>	<b>021-886</b>
XR100R	98-03	_____	<b>018-880</b>	<b>021-886</b>
CT110 Trail 110	80-84	_____	_____	<b>021-884</b>
CT110 Trail 110	1986	_____	_____	<b>021-884</b>
CR125R	81-83	_____	_____	<b>018-113</b>
CR125R	84-99	_____	<b>018-883</b>	<b>018-113</b>
CR125R	00-01	<b>002-877</b>	_____	_____
CR125R	02-07	<b>002-877</b>	_____	<b>007-753</b>
NX125	88-90	_____	<b>021-862</b>	<b>021-886</b>
XL125 Carb ID PD65A	1976	_____	<b>018-880</b>	<b>021-886</b>
XL125	77-78	_____	<b>018-880</b>	<b>021-886</b>
XL125S	79-82	_____	<b>018-880</b>	<b>021-886</b>
XL125S	84-85	_____	<b>018-880</b>	<b>021-886</b>
CRF150F	03-09	_____	_____	<b>021-886</b>
CRF150R	07-09	_____	_____	<b>021-731</b>
CRF150R	2012	_____	_____	<b>021-731</b>
CRF150RB	07-09	_____	_____	<b>021-731</b>
CRF150RB	2012	_____	_____	<b>021-731</b>
XL185S	79-82	_____	<b>018-880</b>	<b>021-886</b>
XL185S	1983	_____	<b>021-861</b>	<b>021-886</b>
XR185	1979	_____	<b>018-880</b>	<b>021-886</b>
TLR200 Reflex	86-87	_____	_____	_____

## Honda Dual Sport & Offroad

Model	Year	Needle Valve Assy	Needle Valve	Float Bowl Gasket/O-Ring
TR200 Fatcat	1986	_____	<b>021-862</b>	<b>021-886</b>
TR200 Fatcat	1987	_____	<b>021-861</b>	<b>021-886</b>
XL200R	83-84	_____	<b>021-861</b>	<b>021-886</b>
XR200	80-84	_____	<b>018-880</b>	<b>021-886</b>
XR200R	81-88	_____	<b>018-880</b>	<b>021-886</b>
XR200R	90-97	_____	<b>018-880</b>	<b>021-886</b>
XR200R	98-02	_____	_____	<b>021-886</b>
CRF230F	03-07	_____	_____	<b>021-886</b>
CRF230L	08-09	_____	_____	<b>021-880</b>
CRF230M	2009	_____	_____	<b>021-880</b>
CR250R	81-83	_____	_____	<b>018-113</b>
CR250R	84-96	_____	<b>018-883</b>	<b>018-113</b>
CR250R	97-98	_____	<b>018-883</b>	<b>021-872</b>
CR250R	99-00	_____	<b>018-884</b>	<b>018-113</b>
CR250R	01-03	<b>002-877</b>	_____	_____
CR250R	04-07	<b>002-877</b>	_____	<b>007-753</b>
CRF250R	04-09	_____	<b>018-884</b>	<b>021-731</b>
CRF250X	04-09	_____	<b>018-884</b>	<b>021-731</b>
CRF250X	2012	_____	<b>018-884</b>	<b>021-731</b>
NX250	88-90	_____	<b>021-862</b>	_____
XL250K/K1/K2 Motosport	72-75	_____	_____	<b>021-889</b>
XL250 Motosport	1976	_____	_____	<b>021-889</b>
XL250S	78-81	_____	<b>018-880</b>	<b>021-886</b>
XL250R	82-83	_____	<b>021-861</b>	<b>021-886</b>
XL250R	84-87	_____	<b>018-880</b>	<b>021-886</b>
XR250L	91-96	_____	<b>021-862</b>	<b>021-886</b>
XR250	79-80	_____	<b>018-880</b>	<b>021-886</b>
XR250R	81-82	_____	<b>018-880</b>	<b>021-886</b>
XR250R	84-85	_____	<b>018-880</b>	_____
XR250R	86-04	_____	<b>018-880</b>	<b>021-886</b>
XL350	76-78	_____	<b>018-880</b>	_____
XL350R	84-85	_____	<b>018-880</b>	_____
XR350R	83-85	_____	<b>018-880</b>	_____
XR400R	96-04	_____	<b>018-883</b>	<b>021-886</b>
CR450R	1981	_____	_____	<b>018-113</b>
CRF450R	02-08	_____	<b>018-884</b>	<b>021-731</b>
CRF450X	05-09	_____	<b>018-884</b>	<b>021-731</b>
CRF450X	2012	_____	<b>018-884</b>	<b>021-731</b>
CR500R	84-01	_____	<b>018-883</b>	<b>018-113</b>
XL500S	79-81	_____	<b>018-880</b>	<b>021-886</b>
XL500R	1982	_____	<b>021-861</b>	<b>021-886</b>
XR500	79-80	_____	<b>018-880</b>	<b>021-886</b>
XR500R	81-82	_____	<b>018-880</b>	<b>021-886</b>
XR500R	83-84	_____	<b>018-880</b>	_____
XL600R	83-87	_____	<b>018-880</b>	_____
XR600R	85-87	_____	<b>018-880</b>	_____
XR600R	88-00	_____	<b>018-883</b>	<b>021-886</b>
NX650	88-89	_____	<b>021-860</b>	<b>021-880</b>
XR650L Dual Sport	93-09	_____	<b>021-860</b>	<b>021-880</b>
XR650L Dual Sport	2012	_____	<b>021-860</b>	<b>021-880</b>
XR650R	00-07	_____	<b>018-883</b>	<b>021-880</b>

## Kawasaki Street

G3SS/A/B/C/D-90	69-74	_____	_____	<b>007-988</b>
KZ200A1/A2	78-79	_____	_____	<b>021-895</b>
A1/A1SS250 Samurai	1968	_____	_____	_____
EL250B2/B3 Eliminator	88-89	_____	<b>018-880</b>	<b>021-887</b>
EL250E1/E2/E3/E4 Eliminator	91-94	_____	<b>018-880</b>	<b>021-887</b>
EX250E1/E2 Ninja 250R	86-87	_____	<b>018-880</b>	<b>021-887</b>
EX250F2/F3/F4 Ninja 250R	88-90	_____	<b>018-880</b>	<b>021-887</b>
EX250F6-F19 Ninja 250R	92-05	_____	<b>018-880</b>	<b>021-887</b>
EX250F6F/F7F Ninja 250R	06-07	_____	<b>018-880</b>	<b>021-887</b>
EX250J8F/J9F Ninja 250R	08-09	_____	<b>018-880</b>	<b>021-887</b>
EX250JAF/JBF/JCF Ninja 250R	10-12	_____	<b>018-880</b>	<b>021-887</b>
KH250A5 (2-stroke triple)	1976	_____	_____	<b>007-988</b>
KL250A1/A1A/A2 Dual Sport	78-79	_____	<b>018-880</b>	<b>021-889</b>
KL250A3/A4/A5 Dual Sport	80-82	_____	_____	<b>007-991</b>
KL250D2-D22 KLR250	85-05	_____	<b>018-880</b>	<b>021-887</b>
KLX250H6F/H7F Dual Sport	06-07	_____	<b>018-880</b>	<b>021-887</b>

VINTAGE  
INTAKE  
ENGINE  
SUSPENSION  
CONTROL  
ELECTRICAL  
CHEMICAL  
TOOLS  
WATERCRAFT





# Needle Valve Sets, Needle Valves, Gaskets & O-Rings

## Kawasaki Dual Sport & Offroad

Model	Year	Needle Valve Assy	Needle Valve	Float Bowl Gasket/O-Ring
KDX200C3	1988	—	018-884	018-113
KDX200E1-E6	89-94	—	018-884	018-113
KDX200H1-H11	95-05	—	018-884	018-113
KDX200H6F	2006	—	018-884	018-113
KDX220A4-A12	97-05	—	018-884	018-113
F4-250 Sidewinder	69-70	007-955	—	002-099
F11/A/B-250 Enduro	73-75	007-955	—	002-099
KE250B1/B2/B3	77-79	007-955	—	—
KDX250A1	1980	—	—	002-102
KDX250B1/B2/B3/B4	81-84	—	—	002-102
KDX250D1/D2/D3/D4	91-94	—	018-884	018-113
KL250A1/A1A/A2	78-79	—	018-880	021-889
KL250A3/A4/A5	80-82	—	—	007-991
KL250D2-D22 KLR250	85-05	—	018-880	021-887
KLX250D2/D3/D4 Offroad	94-96	—	018-880	021-887
KLX250H6F/H7F KLX250S	06-07	—	018-880	021-887
KLX250T9F/T9FL KLX250S	2009	—	018-880	021-887
KLX250TAF/TAFL KLX250S	2010	—	018-880	021-887
KLX250W9F/W9FL KLX250SF	2009	—	018-880	021-887
KLX250WAF/WAFL KLX250SF	2010	—	018-880	021-887
KX250A4/A5/A6/A7	78-81	—	—	002-102
KX250B1	1982	—	—	002-102
KX250C1/C2	83-84	—	—	002-102
KX250D1/D2	85-86	—	—	—
KX250E1	1987	—	—	002-102
KX250F1/G1	88-89	—	018-884	018-113
KX250H1/H2	90-91	—	018-884	018-113
KX250J1/J2	92-93	—	018-884	018-113
KX250K1/K2/K3/K4	94-97	—	018-884	018-113
KX250K5	1998	—	018-884	021-872
KX250L1/L2/L3/L4	99-02	—	018-884	021-872
KX250M1/M2	03-04	—	018-884	021-872
KX250R1/R6F/R7F	05-07	—	018-884	021-872
KX250N1/N2 (KX250F)	0405	—	018-884	021-731
KX250T6F/T7F/T8F (KX250F)	06-08	—	018-884	021-731
KX250W9F/XAFB (KX250F)	09-10	—	018-884	021-731
KLX300A2-A10 Offroad	97-05	—	018-880	021-887
KLX300A6F	2006	—	018-880	021-887
F9/A/B/C-350	72-75	007-955	—	—
KLX400A1 KLX400SR Dual Sport	2003	—	—	007-756
KLX400B1 KLX400R w/FCR-H	2003	018-881	018-884	021-055
KX400/A2	7576	—	—	002-102
KDX400A1/A2	7980	—	—	002-102
KDX420B1	1981	—	—	002-102
KX420A1/A2	80-81	—	—	002-102
KDX450A1	1982	—	—	002-102
KLX450A8F/A9F	08-09	—	018-884	021-731
KX450D6F/D7F/D8F (KX450F)	06-08	—	018-884	021-731
KX500A1	1983	—	—	002-102
KX500A2	1984	007-959	—	002-700
KX500B1/B2	85-86	—	—	—
KX500C1	1987	—	—	002-102
KX500D1	1988	—	018-884	018-113
KX500E1-E16	89-04	—	018-884	018-113
KL600A1/B1/B2 KLR600	84-86	—	018-884	021-887
KL650A10-A19 KLR650	87-05	—	018-884	021-887
KL650A6F/A7F KLR650	06-07	—	018-884	021-887
KL650B2/B3 Tengai KLR650	90-91	—	018-884	021-887
KL650E8F/E9F KLR650	08-09	—	018-884	021-887
KL650EAF-EDF KLR650	10-13	—	018-884	021-887
KLX650A1/A2/A3 Offroad	93-95	—	018-884	021-887
KLX650C1C4 Dual Sport	93-96	—	018-884	021-887
KLX650D1 Offroad	1996	—	018-884	021-887

## Suzuki Street

Model	Year	Needle Valve Assy	Needle Valve	Float Bowl Gasket/O-Ring
GN125Z/D	82-83	007-957	—	—
GN125EM-EV	91-97	007-957	—	—
GN250Z/D	82-83	007-970	—	007-991
GN250F	1985	007-970	—	007-991
GN250J	1988	007-970	—	007-991
GS250TT/TX	80-81	007-957	—	—
GT250K/L/M/A/B Hustler	73-77	007-966	—	002-099
GZ250X/Y	99-00	—	—	007-756
GZ250K1-K9	01-09	—	—	007-756
GZ250L0 Marauder	2010	—	—	007-756
GS300LZ/LD	82-83	007-957	—	—
GS300LF	1985	007-957	—	—
T350III Rebel	69-70	—	—	002-099
T350R/J Rebel	71-72	—	—	002-099
GT380K/L/M/A/B Sebring	73-77	—	—	002-099
DR-Z400SY-SK9 Dual Sport	00-09	—	—	007-756
DR-Z400SL1/SL2 Dual Sport	11-12	—	—	007-756
DR-Z400SM Supermotard	05-09	—	—	007-756
GN400T/XT/XX/TX/TX	80-82	—	—	007-991
GS400B/XB	1977	—	—	007-989
GSF400FM/FN/FP Bandit	91-93	—	—	021-876
GS450ED	1983	007-957	—	—
GS450GAZ/GAD Automatic	82-83	007-957	—	—
GS450GAF Automatic	1985	007-957	—	—
GS450LD	1983	007-957	—	007-990
GS450LF/LG/LH/LJ	85-88	007-957	—	007-990
GS450TXD	1983	007-957	—	007-990
GS500EK-EY	89-00	007-971	—	021-876
GS500EK1/EK2	01-02	—	—	021-876
GS500FK4-FK9	04-09	—	—	007-756
GS500HK7/HK8/HK9 Naked	07-09	—	—	007-756
GT500A/B Titan	76-77	—	—	002-099
T500R/J/K/L/M Titan	71-75	—	—	002-099
GS550B/C/EC	77-78	007-966	—	007-994
GS550N/EN/LN	1979	007-966	—	007-994
GS550ET	1980	007-957	—	007-990
GS550ED/ESD	1983	—	—	—
GS550ES3/ESE/EF/ESF/ESG	83-86	—	—	—
GS550LT/LX/LZ	80-82	007-957	—	007-990
GS550LD	1983	—	—	—
GS550LF/LG	85-86	—	—	—
GS550MZ	1982	007-957	—	007-990
GS550TX	1981	007-957	—	007-990
GT550J Indy (marked 34013/34014)	1972	—	—	002-009
GT550J Indy (marked 34015)	1972	—	—	002-009
GT550K/L/M/A/B Indy	73-77	007-966	—	002-099
GSF600ST-SX Bandit	96-99	—	018-880	021-887
GSF600SY/SK1-SK3 Bandit	00-03	—	018-880	021-887
GSX600FJ/FK Katana	88-89	007-957	—	021-875
GSX600FL-FT Katana	90-96	—	—	021-876
GSX600FV Katana (49 state)	1997	—	—	021-876
GSX600FV Katana (Ca.)	1997	—	—	021-876
GSX600FW/FX/FY Katana	98-00	—	—	007-756
GSX600FK1-FK6 Katana	01-06	—	—	007-756
GSX-R600V/W/X/Y	97-00	—	—	021-877
GR650D/XD Tempter	1983	007-957	—	007-990
GS650EX/EZ	81-82	007-957	—	007-990
GS650GX/GZ/GD	81-83	007-957	—	007-990
GS650GLX/GLZ/GLD	81-83	007-957	—	007-990
GS650MD Katana	1983	007-957	—	007-990
Boulevard S40K5-K9 (LS650)	05-09	007-970	—	007-991
Boulevard S40L1/L2 (LS650)	11-12	007-970	—	007-991
LS650FG/FH Savage	86-87	007-970	—	007-991
LS650PG/PH/PJ Savage	86-88	007-970	—	007-991
LS650PS-PK4 Savage	95-04	007-970	—	007-991
SV650X/Y/K1/K2	99-02	—	—	021-877
SV650SX/SY/SK1/SK2	99-02	—	—	021-877
GS700EF/ESF	1985	007-957	—	007-990
GV700GLF Madura	1985	007-957	—	—
GV700GLF2 Madura	1985	007-957	—	—
GS750B/C/EC	77-78	007-966	—	007-994
GS750N/EN/LN	1979	007-966	—	007-994

# Needle Valve Sets, Needle Valves, Gaskets & O-Rings

## Suzuki Street

Model	Year	Needle Valve Assy	Needle Valve	Float Bowl Gasket/O-Ring
GS750ET/EX/EZ	80-82	007-957	—	007-990
GS750ED/ESD	1983	007-957	—	007-990
GS750LT/LX	80-81	007-957	—	007-990
GS750TZ/TD	82-83	007-957	—	007-990
GS750SD Katana	1983	007-957	—	007-990
GSX750FK-FV Katana	89-97	—	—	021-876
GSX750FW/FX/FY Katana	98-00	—	—	007-756
GSX750FK1-FK6 Katana	01-06	—	—	007-756
GSX-R750G/H	86-87	007-957	—	021-875
GSX-R750RG	1986	007-957	—	021-875
GSX-R750J/K	88-89	—	—	021-876
GSX-R750L/M/N (49 state)	90-92	007-972	—	021-876
GSX-R750L/M/N (Ca.)	90-92	—	—	021-876
GSX-R750WP/WR/WS (49 state)	93-95	007-972	—	021-876
GSX-R750WP/WR/WS (Ca.)	93-95	—	—	021-876
GSXR750TV	96-97	—	—	021-877
GT750J/K Lemans	72-73	—	—	002-099
GT750L/M/A/B Lemans	74-77	007-976	—	007-989
VL800K1/K2/K3/K4 Volusia	01-04	—	—	021-877
VL800ZK Volusia Limited Edition	01-05	—	—	021-877
VS800GLN/GLP/GLR Intruder	92-94	—	—	—
VS800GLS/GLT/GLV Intruder	95-97	—	—	—
VS800GLW/GLX/GLY Intruder	98-00	—	—	—
VS800GLK1/GLK2 Intruder	01-02	—	—	—
VX800L/M/N/P	90-93	—	—	—
VZ800V/W/X/Y Marauder	97-00	—	—	—
VZ800K1/K2 Marauder	01-02	—	—	—
GS850GN	1979	007-966	—	007-994
GS850GT/GX/GZ/GD	80-83	007-957	—	007-990
GS850GLT/GLX/GLZ/GLD	80-83	007-957	—	007-990
GS1000C/EC/N/EN	78-79	007-966	—	007-994
GS1000ET	1980	007-957	—	007-990
GS1000GT/GX	81-82	007-957	—	007-990
GS1000GLT/GLX	81-82	007-957	—	007-990
GS1000LN	1979	007-966	—	007-994
GS1000SN	1979	007-966	—	007-994
GS1000ST	1980	007-957	—	007-990
GS1000SZ Katana	1982	007-957	—	007-990
GS1100ET/EX/EZ/ED/ESD	80-83	007-957	—	007-990
GS1100GZ/GLZ/GD/GLD	82-83	007-957	—	007-990
GS1100GKZ/GK2/GKD/GKE	82-84	007-957	—	007-990
GS1100LT	1980	007-957	—	007-990
GS1100SD Katana	1983	007-957	—	007-990
GSX1100FJ-FP Katana	88-93	—	—	021-875
GSX1100GM/GN/GP Shaft	91-93	007-971	—	021-876
GSX-R1100G/H/J	86-88	007-957	—	021-875
GSX-R1100K/L/M/N	89-92	—	—	021-876
GSX-R1100WP-VWV	93-98	007-972	—	021-876
GS1150ES3/ESE/EF/ESF	83-85	007-957	—	007-990
GS1150EF2/EG/ESG	85-86	007-957	—	007-990
GSF1200K1-K5 Bandit	01-05	—	—	007-756
GSF1200SAV Bandit S	1997	007-972	—	021-876
GSF1200SV-SY Bandit S	97-00	007-972	—	021-876
GSF1200SK1-SK5 Bandit S	01-05	—	—	007-756
GV1200GLF/GLG Madura	85-86	007-957	—	—
GV1200GLF2 Madura	1985	007-957	—	—
VL1500LCV-LCK4 Intruder LC	98-04	—	—	021-877

## Suzuki ATV

LT185E/F/G/H Quadrunner	84-87	—	—	—
LT230EH/EJ/EK/EL Quadrunner	87-90	—	—	—
LT230EM/EN/EP Quadrunner	91-93	—	—	—
LT230GEF/GEG Quadrunner	85-86	—	—	—
LT230SF/SG/SH/SJ Quadrunner	85-88	—	—	—
LT-F230G/H	86-87	—	—	—
LT250EFF/EFQ Quadrunner	85-86	—	—	—
LT250RF/RG Quadrunner	85-86	007-959	—	002-700
LT250RH/RJ/RK Quadrunner	87-89	007-959	—	002-700
LT250RL/RM/RN Quadrunner	90-92	007-959	—	002-700
LT250SK/SL Quad Sport	89-90	—	—	—
LT-F250FX/FY/FK1/FK2	99-02	007-959	—	—

## Suzuki ATV

Model	Year	Needle Valve Assy	Needle Valve	Float Bowl Gasket/O-Ring
LT-F250FX Quad Runner 4WD	1999	007-957	—	021-875
LT-F250FY Quad Runner 4WD	2000	—	—	007-756
LT-F250FK1/FK2 Quad Runner 4WD	01-02	—	—	007-756
LT-F250J/K Quad Runner 2WD	88-89	007-957	—	—
LT-F250L/M/N/P Quad Runner 2WD	90-93	007-957	—	—
LT-F250R-X Quad Runner 2WD	94-99	007-957	—	—
LT-F250Y/K1 Quad Runner 2WD	00-01	—	—	007-756
LT-Z250K4-K9 Quad Sport Z250	04-09	—	—	007-756
LT-4WDH/WDJ/WDK 4x4	87-89	007-967	—	—
LT-4WDL/M/N/P/R/S/T 4x4	90-96	007-957	—	—
LT-300EH/EJ/EK Quadrunner	87-89	—	—	—
LT-300EH/EJ/EK Quadrunner	87-89	—	—	—
LT-F300FX King Quad 4WD (Ca.)	1999	—	—	021-875
LT-F300FX King Quad 4WD 49 state	1999	007-957	—	021-875
LT-F300FY/FK1/FK2 King Quad 4WD	00-02	—	—	007-756
LT-F4WDXM/N/P/R King Quad 300	91-94	—	—	—
LT-F4WDXS/T/V/W King Quad 300	95-98	—	—	—
LT-F4WDXW/WDW	97-98	—	—	—
LT-A400FK2/FK3 Eiger Auto 4WD	02-03	—	018-884	021-887
LT-A400FK4/FK5 Eiger Auto 4WD	04-05	—	—	021-887
LT-A400FCK3 Eiger Auto 4WD	2003	—	—	021-887
LT-A400FCK4 Eiger Auto 4WD	2004	—	—	021-887
LT-A400K2-K5 Eiger Auto 2WD	02-05	—	—	021-887
LT-F400FK2/FK3/FK4 Eiger 4WD	02-04	—	—	021-887
LT-F400K2/K3/K4/K5 Eiger 2WD	02-05	—	—	021-887
LT-400K2/K3 Eiger 2WD	02-03	—	—	021-887
LT-Z400K3/K4/K5/K6 Quad Sport	03-06	—	—	007-756
LT-A500FK2/FK3 Vinson 4WD	02-03	—	018-884	021-887
LT-A500FK4/FCK4 Vinson 4WD	2004	—	018-884	021-887
LT-F500FK3 Vinson Manual 4WD	2003	—	018-884	021-887
LT-F500FK4 Vinson Manual 4WD	2004	—	018-884	021-887
LT500RH/RJ/RK/RL Quadzilla	87-90	007-959	—	007-700

## Suzuki Dual Sport & Offroad

RM60K3/K4	03-04	007-955	—	007-250
RM65K3/K4/K5	03-05	002-892	—	007-250
DS80D-Y	83-00	—	—	007-282
RM80T/X/Z/D/E/F	80-85	—	—	007-251
RM80G/H/J/K	86-89	—	—	007-251
RM80L-K1	90-01	—	—	—
RM85K2/K3/K4/K5/K6/K7/K8	02-08	—	018-885	018-406
RM85LK3-LK8	03-08	—	018-885	018-406
RV90J/K/L/M/A/B Rover	72-77	—	—	007-282
DR100D/E/F/G/H/J/K/L	83-90	007-967	—	—
RM100K3	2003	—	018-885	018-406
SP100D	1983	007-967	—	—
TS100C/N/T/X	78-81	007-966	—	002-009
DR-Z110K3/K4/K5	03-05	—	—	021-884
DR125G/H/J	86-88	007-967	—	—
DR125SER-SET Dual Sport	94-96	007-957	—	021-875
DR-Z125K3-K9	03-09	—	—	—
DR-Z125LK3-LK9	03-09	—	—	—
RM125E/F/G	84-86	007-959	—	002-700
RM125H (up to engine no.106550)	1987	007-959	—	002-700
RM125H	1987	007-959	—	—
RM125J/K/L/M/N/P	88-93	002-466	—	002-484
RM125R/S/T/V/W	94-98	—	018-884	018-113
RM125X/Y	99-00	—	018-884	021-872
RM125K1-K8	01-08	007-954	—	007-753
SP125G/H/J	86-88	007-967	—	—
TC125K/L/M/A/B Prospector	73-77	—	—	002-009
TS125R/J/K/L/M/A/B Duster	71-77	—	—	002-009
TS125C/N/T/X	78-81	007-966	—	002-009
DS185C/N/T	78-80	—	—	007-251
TC185L/M/A/B/C/N Ranger	74-77	—	—	002-009
TS185R/J/K/L/M Sierra	71-75	—	—	002-009
TS185A Sierra	1976	—	—	007-251
TS185B/C/N	77-79	—	—	007-251





# Needle Valve Sets, Needle Valves, Gaskets & O-Rings

## Yamaha Street

Model	Year	Needle Valve Assy	Needle Valve	Float Bowl Gasket/O-Ring
FZR750RT/RU	87-88	---	---	---
TX750/A	73-74	007-958	---	007-989
TZ750A Road Racer (2-stroke)	1974	007-962	---	---
TZ750D Road Racer (2-stroke)	1977	007-962	---	---
XJ750J/K Maxim	82-83	026-302	---	026-320
XJ750MK Midnight Maxim	1983	026-302	---	026-320
XJ750RH/RJ/RK Seca	81-83	026-302	---	026-320
XS750D/2D	1977	007-976	---	007-989
XS750E/F	78-79	007-976	---	007-991
XS750SE/SF Special	78-79	007-976	---	007-991
XV750H/J/K Virago	81-83	026-302	---	026-322
XV750MK Midnight Virago	1983	026-302	---	026-322
XV750U/UC-G/GC Virago	88-95	007-980	---	---
XV750H1/HC1/J1/JC1 Virago	96-97	007-980	---	---
XV750K1/KC1 Virago	1998	007-980	---	---
XS850G/H	80-81	026-300	---	026-326
XS850LG/LH Midnight Special	80-81	026-300	---	026-326
XS850SG/SH Special	80-81	026-300	---	026-326
XJ900RK Seca	1983	---	---	---
XV920J Virago	1982	026-302	---	026-322
XV920K Virago	1983	026-302	---	026-324
XV920MK Midnight Virago	1983	026-302	---	026-324
FZ1000S/SC/T/TC FZ1	04-05	---	---	007-756
FZ1000S1S FZ1	2004	---	---	007-756
FZR1000T/TC/U/UC	87-88	---	---	---
FZR1000W/W-F/FC	89-94	---	---	---
FZS1000N/NC-T/TC FZ1	01-05	---	---	007-756
FZS1000SPR/SPRC FZ1	2003	---	---	007-756
XV1000L/LC/N/NC Virago 1000	84-85	026-302	---	026-324
YZF-R1K/KC-N/NC YZF-R1	98-01	---	---	021-877
YZF1000RK/RKC YZF-R1	1998	---	---	021-877
YZF-R1SN/SNC YZF-R1	2001	---	---	021-877
FJ1100L/LC/N/NC	84-85	007-504	---	---
XJ1100J Maxim	1982	007-503	---	007-990
XS1100E/F	78-79	007-976	---	007-991
XS1100G/H	80-81	007-503	---	007-990
XS1100LG/LH Midnight Special	80-81	007-503	---	007-990
XS1100SF Special	1979	007-976	---	007-991
XS1100SG/SH Special	80-81	007-503	---	007-990
XV1100S/SC/T/TC Virago 1100	86-87	026-302	---	026-324
XV1100U/UC-L/LC Virago 1100	88-99	007-980	---	---
XVS1100A V-Star 1100 Classic	99-09	---	---	007-756
XVS1100 V-Star 1100 Custom	---	---	---	007-756
XVS1100T/V V-Star 1100 Custom	---	---	---	007-756
XVS1100T V-Star Midnight Custom	---	---	---	007-756
XVS1100A V-Star 1100 Silverado	---	---	---	007-756
FJ1200S/SC/T/TC	86-87	007-504	---	---
FJ1200W/WC/A/AC	89-90	007-980	---	---
FJ1200B/BC/D/DC	91-92	007-980	---	---
FJ1200AD/ADC/AE/AEC (ABS)	92-93	007-980	---	---
VMX12N/NC-W/W1 V-Max	85-07	---	---	---
XVZ13 Venture & Venture Royale	86-93	---	---	---
XVZ13 Venture & Venture Royale	86-93	---	---	---
XVZ13AH/AHC Royal Star	1996	007-980	---	---
XVZ13ATH/ATHC Royal Star Tour	96-98	007-980	---	---
XVZ13AL/ALC-AN/ANC	99-01	007-980	---	---
XVZ1300C Midnight Tour Deluxe	06-07	---	---	021-877
XVZ1300TF Royal Star Midnight Venture	02-07	---	---	021-877
XVZ1300CT Royal Star Tour Deluxe	05-09	---	---	021-877
XVZ1300C Royal Star Tour Deluxe S	08-10	---	---	021-877
XVZ1300TF Royal Star Venture	99-09	---	---	021-877
XVZ1300TF Royal Star Venture MM	2000	---	---	021-877
XVZ1300TFSM Royal Star Venture MM	2000	---	---	021-877
XVZ1300TFS Royal Star Venture S	08-12	---	---	021-877
XV1600ALE Road Star L.E.	2003	---	---	007-756
XV1600ALM Road Star	99-03	---	---	007-756
XV1600ASM Road Star MM Limited	2000	---	---	007-756
XV1600AS Midnight Star	01-03	---	---	007-756

## Yamaha Street

Model	Year	Needle Valve Assy	Needle Valve	Float Bowl Gasket/O-Ring
XV1600ATL Road Star Silverado L.E.	2003	---	---	007-756
XV1600AT Road Star Silverado	99-03	---	---	007-756
XV1700A Road Star Midnight	04-07	---	---	007-756
XV1700A Road Star Silverado	04-07	---	---	007-756
XV1700A Road Star	04-07	---	---	007-756
XV1700AT Road Star Silverado	04-07	---	---	007-756

## Yamaha ATV

Model	Year	Needle Valve Assy	Needle Valve	Float Bowl Gasket/O-Ring
YFA1W Breeze Moto-4	1989	---	---	007-999
YFA1B-YFA1H Breeze Moto-4	91-96	---	---	007-999
YFA1J-YFA1S/SC Breeze Moto-4	97-04	---	---	007-999
YFM125S/GT/GV Grizzly 125	04-06	---	---	007-999
YFM125GHT Grizzly 125 Hunter	2005	---	---	007-999
YFM125RAL/RAW Raptor 125	2011	---	---	007-756
YT125G/H/J/K/L/N Tri-Moto	80-85	---	---	007-250
YT175J/K Tri-Moto	82-83	---	---	007-250
YFM200N Moto-4	1985	---	---	007-999
YFM200DXS-DXW Moto-4	86-89	---	---	007-999
YFS200U-V/SEV Blaster	88-06	007-979	---	007-250
YTM200K/L/N Tri-Moto	83-84	---	---	007-999
YTM200N Tri-Moto	1985	---	---	007-999
YTM200EK/EL/ERN Tri-Moto	83-85	---	---	007-999
YFM225S/T/U Moto-4	86-88	---	---	007-999
YTM225DRN/DRS Tri-Moto	85-86	---	---	007-999
YTM225DXK/DXL/DXN Tri-Moto	83-85	---	---	007-999
YFU1TW/YFU1W Pro-Hauler	1989	---	---	007-999
YFB250D/E/F/G/H Timberwolf	92-96	---	---	007-999
YFB250FWF/FWG Timberwolf	94-95	---	---	007-999
YFB250FVH/FWJ Timberwolf	96-97	---	---	007-999
YFB250FWK-FWM Timberwolf	98-00	---	---	007-999
YFB250UH/UJ/UK Timberwolf	96-98	---	---	007-999
YFM250BT/BV Bruin 250	05-06	---	---	007-756
YFM250W/A/B Moto-4	89-91	---	---	007-756
YFM250BW/BX Big Bear 250	07-08	---	---	007-756
YFM250BY Big Bear 250	2009	---	---	007-756
YFM250RSP2X Raptor 250 S.E.II	2008	---	---	007-756
YFM250RSPX Raptor 250 S.E.	2008	---	---	007-756
YFM250RX/RXGY/RXL Raptor 250	2008	---	---	007-756
YFM250RSE2Y Raptor 250	2009	---	---	007-756
YFM250RSEY Raptor 250	2009	---	---	007-756
YFM250RYL/RYW/RZW Raptor 250	09-10	---	---	007-756
YFM250RAL/RAW Raptor 250	2011	---	---	007-756
YFM250RSPA Raptor 250 S.E.	2011	---	---	007-756
YFM350AS Bruin 350 Auto 2WD	2004	---	---	007-756
YFM350BA Bruin 2WD	05-06	---	---	007-756
YFM350FAHS Bruin 350 Auto 4x4	2004	---	---	007-756
YFM350FA Bruin 4WD Hunter	04-06	---	---	007-756
YFM350FG Grizzly 350 4WD	09-11	---	---	007-756
YFM350FGI Grizzly 350 IRS	07-11	---	---	007-756
YFM350FG Grizzly 350 4WD	07-10	---	---	007-756
YFM350G Grizzly 350 2WD	07-11	---	---	007-756
YFM350R Raptor 350	04-11	---	---	007-756
YFM350X Wolverine 350 2WD	06-09	---	---	007-756
YFM350AS Bruin 350 Auto 2WD	04-05	---	---	---
YFM350BAT Bruin 350 2WD	2005	---	---	---
YFM350ERD-ERG Moto-4	92-95	007-977	---	---
YFM350ER Moto-4	87-90	007-977	---	---
YFM350FAHS Bruin 350 Auto	04-05	---	---	---
YFM350FAS Bruin 350 Auto 4x4	2004	---	---	---
YFM350FAT Bruin 350 Auto 4x4	2005	---	---	---
YFM350FWBJ Big Bear 4WD	1997	---	---	021-875
YFM350FWT-FWJ Big Bear	87-97	007-977	---	---
YFM350FXG Wolverine	1995	007-977	---	---
YFM350FXH-FXT Wolverine	96-05	---	---	021-875
YFM350S/RT Raptor 350	04-05	---	---	---
YFM350UH/UJ/UK Big Bear 2WD	96-98	007-977	---	---

VINTAGE  
INTAKE  
ENGINE  
SUSPENSION  
CONTROL  
ELECTRICAL  
CHEMICAL  
TOOLS  
WATERCRAFT



# Needle Valve Sets, Needle Valves, Gaskets & O-Rings

## Yamaha Dual Sport & Offroad

Model	Year	Needle Valve Assy	Needle Valve	Float Bowl Gasket/O-Ring
WR250FA	2011	---	018-884	021-731
YZ250FN/FP (YZ250F)	01-02	018-881	018-884	021-731
YZ250FR-FX (YZ250F)	03-08	---	018-884	021-731
YZ250FSPV 50Th Anniversary	2006	---	018-884	021-731
YZ250FYL/FYW (YZ250F)	2009	---	018-884	021-731
YZ250FZL/FZW (YZ250F)	2010	---	018-884	021-731
YZ250FAB/FAL (YZ250F)	2011	---	018-884	021-731
YZ250FBL/FBW (YZ250F)	2012	---	018-884	021-731
YZ250A	1974	007-961	---	002-101
YZ250B	1975	007-961	---	---
YZ250C/D	76-77	007-961	---	002-102
YZ250E/F/G/H	78-81	007-960	---	002-102
YZ250J/K/L/M/S/T/U	82-88	007-960	---	002-102
YZ250W/A/B/D/E1/F1	89-94	002-466	---	002-484
YZ250G1/H1/J1/K1	95-98	---	018-884	018-113
YZ250L1/M1/N1/P/R/S1/T1/V	99-06	---	018-884	021-872
YZ250W1/X1/Y1/Z1/A1/B2	07-12	---	018-884	021-872
YZ250WRW/WRA	89-90	002-466	---	002-484
DT360A Enduro	1974	007-955	---	---
MX360/A	73-74	007-961	---	002-101
RT1/RT1B-360 Enduro	70-71	007-961	---	002-009
RT2/RT3-360 Enduro	72-73	007-961	---	002-009
RT1M/RT1MX-360	70-71	007-961	---	002-009
RT2MX-360	1972	007-961	---	002-101
YZ360A	1974	007-961	---	002-101
YZ360B	1975	007-961	---	---
IT400C/D/E/F	76-79	007-960	---	002-102
MX400B	1975	007-960	---	002-102
YZ400C/D/E/F	76-79	007-960	---	002-102
WR400FK/FL	98-99	018-881	018-884	021-055
WR400FM	2000	018-881	018-884	021-731
YZ400FK/FL (YZ400F)	98-99	018-881	018-884	021-055
IT425G	1980	007-960	---	002-102
WR426FN/FP	01-02	018-881	018-884	021-731
YZ426FM/FN/FP (YZ426F)	00-02	018-881	018-884	021-731
WR450FR-FY	03-09	---	018-884	021-731
WR450FA	2011	---	018-884	021-731
YZ450FR-FX (YZ450F)	03-08	---	018-884	021-731
YZ450FSPV 50Th Anniversary	2006	---	018-884	021-731
YZ450FXL/FXW (YZ450F)	2008	---	018-884	021-731
YZ450FYL/FYW (YZ450F)	2009	---	018-884	021-731
IT465H/J	81-82	007-960	---	002-102
YZ465G/H	80-81	007-960	---	002-102
IT490K/L	83-84	007-960	---	002-102
YZ490J/K/L/N/S/T/U/W/A	82-90	007-960	---	002-102
SC500/A Scrambler	73-74	007-960	---	002-102
WR500ZD/ZE	92-93	007-960	---	002-102
TT500C/D	76-77	007-955	---	---
TT500E/F/G/H	78-81	007-963	---	---
XT500E/F Dual Sport	78-79	---	---	007-996



VINTAGE

INTAKE

ENGINE

SUSPENSION

CONTROL

ELECTRICAL

CHEMICAL

TOOLS

WATERCRAFT

# Fuel Valves



## Pingel Power-Flo™ Fuel Valves

People who demand performance demand Pingel® Products. Pingel Fuel Valves provide more fuel flow than OEM petcocks. This is a must with drag racing and high performance applications. Manufactured from billet with high quality stainless steel components. Power-Flo™ fuel valves feature highly polished aluminum or highly polished chrome-plated brass finishes with either 1/4"NPT, 3/8"NPT or HD metric thread 22mm. 5/16" outlet in single, dual or triple with or without reserve. Fuel Valves listed sold each.

Fuel Valve Pingel No.	Reserve	Inlet	Outlet 5/16"	Order No.	Fuel Valve Pingel No.	Reserve	Inlet	Outlet 5/16"	Order No.
1211-AH (Hex)	Yes	3/8" NPT	Single	<b>009-303</b>	4211-AH	Yes	3/8" NPT	Single	<b>009-304</b>
1211-CH6	Yes	3/8" NPT	Single	<b>009-320</b>	4211-CH6	Yes	3/8" NPT	Single	<b>009-323</b>
1311-AH (Hex)	Yes	22mm Metric	Single	<b>009-300</b>	4311-AH	Yes	22mm Metric	Single	<b>009-301</b>
1311-CH	Yes	22mm Metric	Single	<b>009-328</b>	4321-CH	Yes	22mm Metric	Single	<b>009-324</b>
3110-D-AH	No	1/4" NPT	Dual	<b>009-309</b>	6111-AH	Yes	1/4" NPT	Single	<b>009-307</b>
3110-D-AH16A	No	1/4" NPT	Dual	<b>009-331</b>	6210-AH	No	3/8" NPT	Single	<b>009-314</b>
3210-D-AH	No	3/8" NPT	Dual	<b>009-310</b>	6211-AH	Yes	3/8" NPT	Single	<b>009-305</b>
3211-D-AH	Yes	3/8" NPT	Dual	<b>009-311</b>	6211-CH	Yes	3/8" NPT	Single	<b>009-336</b>
32GSXR	No	3/8" NPT	Dual	<b>009-312</b>	6211-CR	Yes	3/8" NPT	Single	<b>009-337</b>
3311-D-AH	Yes	22mm Metric	Dual	<b>009-334</b>	6311-AH	Yes	22mm Metric	Single	<b>009-302</b>
4110-AH61A	No	1/4" NPT	Single	<b>009-338</b>	6381-CH	Yes	22mm Metric	Single	<b>009-327</b>
4111-CH3	Yes	1/4" NPT	Single	<b>009-322</b>	8210-T-AH	No	3/8" NPT	Triple	<b>009-316</b>



## Fuel Valve Adapter Plates

2 bolt tank pattern adapter plates to NPT. The adapter plate is bolted to the tank with the fuel valve threaded into or onto the plate. Adapter plates come complete with gasket, screws, copper sealing washers and hylomar sealer.

Description	Pingel No.	Order No.
<b>1/4" NPT</b>		
34mm bolt center	A1601C	<b>009-369</b>
<b>3/8" NPT</b>		
34mm bolt center	A1602C	<b>009-350</b>
44mm bolt centers	A1702C	<b>009-352</b>
44mm with offset center hole	A1702C-O	<b>009-353</b>
46mm bolt centers	A1802C	<b>009-355</b>
50mm bolt centers	A1902C	<b>009-357</b>
Blank, drill your own	A1902C-B	<b>009-359</b>



## Chrome Plated Adapter Nuts

The adapter nut is threaded onto the tank with the fuel valve threaded into the nut. Adapter comes with nylon gasket. Sold each.

Description	Pingel No.	Order No.
Adapts 13/16" or 20mm diameter threaded male tank bung to 1/4" NPT valves	A2000C	<b>009-370</b>
Adapts 7/8" or 22mm diameter threaded male tank bung to 3/8" NPT valves	A2001C	<b>009-365</b>
Adapts 15/16" or 24mm diameter threaded male tank bung to 3/8" NPT valves	A2002C	<b>009-366</b>
Adapts 11/16" or 18mm diameter threaded male tank bung to 1/4" NPT valves	A2003C	<b>009-371</b>
Adapts 22mm diameter threaded male tank bung to 22mm NPT valves	A3001C	<b>009-368</b>

## Honda

Model	Year	Fuel Valve Pingel No.	Reserve	Number of Outlets	Size of Outlets	Order No.	Description/Notes	Adapter Pingel No.	Order No.
CB550		6111-AH	Yes	Single	5/16" /straight	<b>009-307</b>	Adapter nut required	A2000C	<b>009-370</b>
CBR600F2/F3 Hurricane	91-98	3311-D-AH	Yes	Dual	5/16" /straight	<b>009-334</b>	Adapter included	—	—
CBR600F4 Hurricane		3311-D-AH	Yes	Dual	5/16" /straight	<b>009-334</b>	Adapter included	A2003C	<b>009-370</b>
CB750F Super Sport		6111-AH	Yes	Single	5/16" /straight	<b>009-307</b>	Adapter nut required	—	—
VF750C Magna		4321-CH	Yes	Single	3/8" /straight	<b>009-324</b>	Adapter included	—	—
VF750S Sabre		6111-AH	Yes	Single	5/16" /straight	<b>009-307</b>	Adapter nut required	A2000C	<b>009-370</b>

## Honda

Model	Year	Fuel Valve Pingel No.	Reserve	Number of Outlets	Size of Outlets	Order No.	Description/Notes	Adapter Pingel No.	Order No.
CBR900RR	93-99	3311-D-AH	Yes	Dual	5/16" /straight	009-334	Adapter included	_____	_____
CB1100F Super Sport	1983	6111-AH	Yes	Single	5/16" /straight	009-307	Adapter nut required	A2000C	009-370
CBX	79-81	6111-AH	Yes	Single	5/16" /straight	009-307	Adapter nut required	A2003C	009-371
CBX	1982	6111-AH	Yes	Single	5/16" /straight	009-307	Adapter nut required	A2000C	009-370
VT1100 Aero		6381-CH	Yes	Single	3/8" /90° down	009-327	Adapter included	_____	_____
VT1100 Shadow		4111-CH3	Yes	Single	5/16" /straight	009-322	Adapter included	_____	_____
VT1100 Shadow ACE		6381-CH	Yes	Single	3/8" /90° down	009-327	Adapter included	_____	_____
VT1100 Shadow Spirit		6381-CH	Yes	Single	3/8" /90° down	009-327	Adapter included	_____	_____
GL1500 Valkyrie	97-01	1311-CH	Yes	Single	5/16" /straight	009-328	Adapter included	_____	_____

## Kawasaki

S1A/S1B/S1C-250	73-75	8210T-AH	No	Triple	5/16" /straight	009-316	Adapter nut required	A2001C	009-365
KH250A5	1976	8210T-AH	No	Triple	5/16" /straight	009-316	Adapter nut required	A2001C	009-365
S2/S2A-350	72-73	8210T-AH	No	Triple	5/16" /straight	009-316	Adapter nut required	A2001C	009-365
S3/S3A-400	74-75	8210T-AH	No	Triple	5/16" /straight	009-316	Adapter nut required	A2001C	009-365
KH400A3/A4/A5	76-78	8210T-AH	No	Triple	5/16" /straight	009-316	Adapter nut required	A2001C	009-365
H1/H1A/H1B/H1C-500	69-72	8210T-AH	No	Triple	5/16" /straight	009-316	Adapter nut required	A2002C	009-366
H2/H2A/H2B/H2C-750	72-75	8210T-AH	No	Triple	5/16" /straight	009-316	Adapter nut required	A2002C	009-366
Z1/A/B-900, KZ900A4/A5	73-77	6311-AH	Yes	Single	5/16" /straight	009-302	Adapter included	_____	_____
		3311-D-AH	Yes	Dual	5/16" /straight	009-334	Adapter included	_____	_____
ZX900 Ninja ZX-9R	98-01	4121-AH	Yes	Single	5/16" /straight	009-306	Adapter plate required	A1601C	009-369
KZ1000 w/thread on valve		6311-AH	Yes	Single	5/16" /straight	009-302	Adapter included	_____	_____
		3311-D-AH	Yes	Dual	5/16" /straight	009-334	Adapter included	_____	_____
KZ1000/1100 w/bolt on vlv.		6211-AH	Yes	Single	5/16" /straight	009-305	Adapter plate required	A1702C	009-352
		3211-D-AH	Yes	Dual	5/16" /straight	009-311	Adapter plate required	A1702C	009-352
ZG1000 Concours	2004	6211-CH (Hex)	Yes	Single	5/16" /straight	009-336	Adapter plate required	A1702C	009-352
		6211-CR (Round)	Yes	Single	5/16" /straight	009-337	Adapter plate required	A1702C	009-352
KZ1300A	79-82	6211-AH	Yes	Single	5/16" /straight	009-305	Adapter plate required	A1702C	009-352
VN1500 Vulcan		1211-CH6	Yes	Single	5/16" /straight	009-320	Adapter included	_____	_____

## Suzuki

GSF600/1200 Bandit		4211-AH	Yes	Single	5/16" /straight	009-304	Adapter plate required	A1602C	009-350
		3211-D-AH	Yes	Dual	5/16" /straight	009-311	Adapter plate required	A1602C	009-350
GS750/1000/1100E	79-83	6211-AH	Yes	Single	5/16" /straight	009-305	Adapter plate required	A1702C	009-352
Order adapter plate required		3211-D-AH	Yes	Dual	5/16" /straight	009-311	Adapter plate required	A1902C	009-357
GS1150E	84-85	6211-AH	Yes	Single	5/16" /straight	009-305	Adapter plate required	A1702C	009-352
Order adapter plate required		3211-D-AH	Yes	Dual	5/16" /straight	009-311	Adapter plate required	A1902C	009-357
GSX-R750	86-95	32GSXR-D-AH	No	Dual	3/8" /90° down	009-312	Adapter plate required	A1702C-0	009-353
GSX-R750	96-98	32GSXR-D-AH	No	Dual	3/8" /90° down	009-312	Adapter plate required	A1602C	009-350
GSX-R1100	86-98	32GSXR-D-AH	No	Dual	3/8" /90° down	009-312	Adapter plate required	A1702C-0	009-353
GSX1100F Katana		3211-D-AH	Yes	Dual	5/16" /straight	009-311	Adapter plate required	A1702C	009-352
Order adapter plate required							Adapter plate required	A1902C	009-357

## Triumph

All Models	92-99	6211-AH	Yes	Single	5/16" /straight	009-305	Adapter plate required	A1602C	009-350
		6211-CH	Yes	Single	5/16" /straight	009-336	Adapter plate required	A1602C	009-350
All Models	04-05	6211-CH	Yes	Single	5/16" /straight	009-336	Adapter plate required	A1602C	009-350
		6211-CR	Yes	Single	5/16" /straight	009-337	Adapter plate required	A1602C	009-350

## Yamaha

YZ85	02-07	4110-D-AH61A	No	Single	5/16" /straight	009-338	Adapter included	_____	_____
YFS200 Blaster ATV	98-06	4110-D-AH61A	No	Single	5/16" /straight	009-338	Adapter included	_____	_____
YZ250F	01-07	4110-D-AH61A	No	Single	5/16" /straight	009-338	Adapter included	_____	_____
YFM350 Warrior ATV	87-94	4110-D-AH61A	No	Single	5/16" /straight	009-338	Adapter included	_____	_____
YFM350 Raptor ATV	05-06	4110-D-AH61A	No	Single	5/16" /straight	009-338	Adapter included	_____	_____
YFZ350 Banshee ATV	87-05	3210-D-AH	No	Dual	5/16" /straight	009-310	Adapter plate required	A1602C	009-350
		3110-D-AH61A	No	Dual	5/16" /straight	009-331	Adapter included	_____	_____
		3211-D-AH	Yes	Dual	5/16" /straight	009-311	Adapter plate required	A1602C	009-350
		4110-D-AH61A	No	Single	5/16" /straight	009-338	Adapter included	_____	_____
YZ400F/YZ426/YZ450	98-07	4110-D-AH61A	No	Single	5/16" /straight	009-338	Adapter included	_____	_____
YFZ450 ATV	04-06	4110-D-AH61A	No	Single	5/16" /straight	009-338	Adapter included	_____	_____
YFM660R Raptor ATV	01-05	4110-D-AH61A	No	Single	5/16" /straight	009-338	Adapter included	_____	_____
XVS650 V-Star Street		4211-CH6	Yes	Single	5/16" /straight	009-323	Adapter included	_____	_____
FZR1000 Street	87-95	6211-AH	Yes	Single	5/16" /straight	009-305	Adapter plate required	A1602C	009-350
		3211-D-AH	Yes	Dual	5/16" /straight	009-311	Adapter plate required	A1602C	009-350
YZF-R1 Street		4211-AH	Yes	Single	5/16" /straight	009-304	Adapter plate required	A1602C	009-350
XVZ13 Royal-Star Street		4211-CH6	Yes	Single	5/16" /straight	009-323	Adapter included	_____	_____
XVZ1600 Road Star		4211-CH6	Yes	Single	5/16" /straight	009-323	Adapter included	_____	_____



# Fuel Petcock Repair Kits



009-405



009-402

## Fuel Petcock Repair Kits

Kit contains all necessary o-rings and diaphragms to rebuild one fuel petcock. Sold in kits. **Made in Japan.** Note: Does not include plastic diaphragm spacer block. **Kawasaki & Yamaha applications with an asterisk \* may require longer bolts.**

### Honda Street

Model	Year	Fuel Petcock Repair Kit	Diaphragm Only
VTR250 Interceptor	88-90	009-405	—
CB450SC Nighthawk	85-86	009-405	—
CMX450C Custom	86-87	009-405	—
CX500C Custom	81-82	009-405	—
CX500D Deluxe	81-82	009-405	—
FT500 Ascot	82-83	009-405	—
GL500I Silverwing Interstate	81-82	009-405	—
VT500C Shadow	83-86	009-405	—
VT500FT Ascot	1984	009-405	—
CB550SC Nighthawk	1983	009-405	—
XL600V Transalp	89-90	009-405	—
CB650SC Nighthawk	83-85	009-405	—
CX650C Custom	1983	009-405	—
GL650I Silverwing Interstate	1983	009-405	—
CB700SC Nighthawk	84-86	009-405	—
VF700S Sabre	84-85	009-405	—

### Kawasaki Street

EX250E1/E2 Ninja 250R	86-87	009-421	009-502
EX250F2-F6F Ninja 250R	88-06	—	009-505
KZ250L1 CSR	1982	009-410	—
KZ250W1 LTD	1983	009-410	—
S1A/B/C-250 (two stroke triple)	73-75	009-414	—
KH250A5 (two stroke triple)	1976	009-414	—
EX305B1 GPz	1983	009-410	—
KZ305A1/A2 CSR	81-82	009-410	—
KZ305B1 LTD	1982	009-410	—
KZ305B LTD Belt (manual, US Model)	87-88	009-410	—
KZ305B LTD Belt (vacuum, Calif. model)	87-88	009-421	009-502
S2/A-350 (two stroke triple)	72-73	009-414	—
S3/A-400 (two stroke triple)	74-75	009-414	—
KH400A3/A4 (two stroke triple)	76-77	009-414	—
KZ440A1/A2/A3/A4 LTD	80-83	009-402	009-501
KZ440B1/B2	80-81	009-402	009-501
KZ440D1/D2/D3/D4/D5 LTD Belt	80-83	009-402	009-501
KZ440G1	1982	009-402	009-501
EN450A1/A2/A3/A4/A5/A6 LTD 454	85-90	009-421	009-502
EN500A1-A7 Vulcan 500	90-96	009-421	009-502
EN500C1-C10 Vulcan 500 LTD	96-05	009-435	009-506
EX500A1/A2/A3/A4/A5/A6/A7	87-93	009-421	009-502
EX500D1-D12 Ninja 500	94-05	009-421	009-502
KZ550A1/A2/A3/A4	80-83	009-402	009-501
KZ550C1/C2/C3/C4 LTD	80-83	009-402	009-501

## Kawasaki Street

Model	Year	Fuel Petcock Repair Kit	Diaphragm Only
KZ550D1 GPz	1981	009-402	009-501
KZ550F1/F2 Spectre & LTD	83-84	009-421	009-502
KZ550H1/H2 GPz	82-83	009-421	009-502
KZ550M1 LTD	1983	009-421	009-502
ZR550B1/B2	90-91	009-435	009-506
ZR550B3/B4 (Canadian models)	92-93	009-435	009-506
ZX550A1/A2 GPz	84-85	009-421	009-502
KL600A1 KLR600	1984	009-410	—
KL600B1/B2 KLR600	85-86	009-410	—
ZL600A1/A2 Eliminator	86-87	009-402	009-501
ZL600B2/B3 Eliminator 600	96-97	009-402	009-501
ZX600A1/A2/A3 Ninja 600R	85-87	009-421	009-502
ZX600B1 Ninja 600RX	1987	009-421	009-502
ZX600C1-C10 Ninja 600R	88-97	—	009-502
ZX600D1/D2/D3/D4 Ninja ZX-6	90-93	009-429	009-505
ZX600E1-E10 Ninja ZX-6	93-02	009-425	—
ZX600F1/F2/F3 Ninja ZX-6R*	95-97	009-424	—
KL650A1-A19 KLR650	87-05	009-421	009-502
KL650A6F/A7F KLR650	06-07	009-421	009-502
KL650B2 Tengai KLR650	1990	009-421	009-502
KZ650B3	1979	009-403	009-500
KZ650E1/F1	1980	009-403	009-500
KZ650H1 CSR	1981	009-402	009-501
KZ650H2/H3 CSR	82-83	009-403	009-500
KZ700A1	1984	009-403	009-500
VN700A1 Vulcan	1985	009-421	009-502
ZN700A1/A2 LTD	84-85	009-421	009-502
KZ750B1/B2/B3/B4 (2 cylinder)	76-79	009-414	—
KZ750E1/E2/E3	80-82	009-403	009-500
KZ750F1 LTD	1983	009-421	009-502
KZ750G1 LTD (2 cylinder)	1980	009-414	—
KZ750H1/H2/H3/H4 LTD	80-83	009-403	009-500
KZ750K1 LTD (2 cylinder)	1983	009-402	009-501
KZ750K2 LTD (2 cylinder, Canadian model)	1984	009-402	009-501
KZ750L3	1983	009-403	009-500
KZ750M1 CSR (2 cylinder)	1982	009-402	009-501
KZ750N1/N2 Spectre	82-83	009-421	009-502
KZ750R1 GPz	1982	009-403	009-500
VN750A2-A21 Vulcan	86-05	009-421	009-502
VN750A6F Vulcan	2006	009-421	009-502
ZR750C1/C2	91-92	009-435	009-506
ZR750C3 (Canadian model)	1993	009-435	009-506
ZR750F2 ZR-7	2000	009-435	009-506
ZX750A1/A2/A3 GPz	83-85	009-403	009-500
ZX750F1/F2/F3/F4 Ninja 750R	87-90	009-429	009-505
ZX750H2 Ninja ZX-7	1990	009-425	—
ZX750J1/J2 Ninja ZX-7	91-92	009-425	—
ZX750K1/K2 Ninja ZX-7R	91-92	009-425	—
ZX750L1/L2/L3 Ninja ZX-7	93-95	009-425	—
ZX750M1/M2 Ninja ZX-7R	93-94	009-425	—
Z1/A/B-900	73-75	009-414	—



009-403



009-424

## Kawasaki Street

Model	Year	Fuel Petcock Repair Kit	Diaphragm Only
KZ900A4/A5	76-77	009-414	—
KZ900B1 LTD	1976	009-414	—
ZL900A1/A2 Eliminator	85-86	009-408	009-500
ZX900A1/A2/A3 Ninja	84-86	009-403	009-500
ZX900B1/B2/B3/B4 Ninja ZX-9R*	94-97	009-424	—
KZ1000A1	1977	009-414	—
KZ1000A2/A2A	1978	009-413	—
KZ1000A3/A3A/A4 MKII	79-80	009-413	—
KZ1000B1/B2/B3/B4 LTD	77-80	009-414	—
KZ1000C1 Police (manual petcock)	1978	009-414	—
KZ1000C1A-C4 Police (vacuum petcock)	78-81	009-413	—
KZ1000D1 Z1R	1978	009-414	—
KZ1000D3 Z1R	1980	009-414	—
KZ1000E1/E2 Shaft ST	79-80	009-407	—
KZ1000G1 LTD Classic	1980	009-414	—
KZ1000J1/J2	81-82	009-407	—
KZ1000K1/K2 LTD	81-82	009-403	009-500
KZ1000M1/M2 CSR	81-82	009-403	009-500
KZ1000P1-P21 Police	82-02	009-403	009-500
KZ1000P24 Police	2005	009-403	009-500
KZ1000R1/R2 Replica	82-83	009-407	—
ZG1000A1-A20 Concours	86-05	009-408	009-500
ZL1000A1 Eliminator	1987	009-408	009-500
ZX1000A1/A2 Ninja 1000R	86-87	009-408	009-500
KZ1100A1/A2/A3 Shaft	81-83	009-407	—
KZ1100D1/D2 Spectre	82-83	009-403	009-500
KZ1100L1 LTD	1983	009-403	009-500
ZN1100B1/B2 LTD 1100	84-85	009-403	009-500
ZR1100A1/A2	92-93	009-435	009-506
ZR1100A3/A4 (Canadian model)	94-95	009-435	009-506
ZR1100C3/C4 ZRX1100	99-00	—	—
ZX1100A1/A2 GPZ	83-84	009-414	—
ZX11000C1/C2/C3/C4 Ninja ZX-11	90-93	009-425	—
ZX11000D1-D9 Ninja ZX-11	93-01	009-425	—
ZX1100E1/E2/E3 GPz	95-97	009-425	—
ZX1100F1 GPz (ABS)	1996	009-425	—

## Kawasaki ATV

KLT110A1/A2/A3	84-86	009-410	—
KLT160A1	1985	009-410	—
KLT185A1/A2	86-87	009-410	—
KLF300A1/A2 Bayou	86-87	009-410	—
KVF400A1/A2 Prairie 400 4x4*	97-98	009-424	—
KVF400C1/C2/C3/C4 Prairie 400 4X4*	99-02	009-424	—
KVF400B1/D1/D2/D3/D4 Prairie 400*	98-02	009-424	—

Kawasaki applications with an asterisk \* may require longer bolts

## Kawasaki Dual Sport & Offroad

Model	Year	Fuel Petcock Repair Kit	Diaphragm Only
KX65A1/A2/A3/A4/A5/A6*	00-05	009-424	—
KX85A1/A2/A3/A4/A5*	01-05	009-424	—
KD80N1/N2/N3	88-90	009-410	—
KX100C1/C2/C3*	98-00	009-424	—
KX100D1/D2/D3/D4/D5*	01-05	009-424	—
KX125J1/J2/K1/K2/K3/K4/K5*	92-98	009-424	—
KX125L1/L2/L3/L4*	99-02	009-424	—
KL250D1-D22 KLR250	85-05	009-410	—
KLX250D2/D3/D4*	94-96	009-424	—
KX250J1/J2*	92-93	009-424	—
KX250K1/K2/K3/K4/K5*	94-98	009-424	—
KX250L1/L2/L3/L4*	99-02	009-424	—
KLX300A2-A10*	97-05	009-424	—
KLX300A6F*/A7F	06-07	009-424	—
KL600A1 KLR600	1984	009-410	—
KL600B1/B2 KLR600	85-86	009-410	—
KL650A1-A19 KLR650	87-05	009-421	009-502
KL650A6F/A7F KLR650	06-07	009-421	009-502
KL650B2 Tengai KLR650	1990	009-421	009-502

## Suzuki Street

GS300LZ/LD	82-83	009-475	009-503
GS300LF	1985	009-475	009-503
GS400B/XB/C/XC	77-78	009-479	009-504
GS425N/EN/LN	1979	009-479	009-504
GS450ED	1983	009-475	009-503
GS450GAZ/GAD Automatic	82-83	009-475	009-503
GS450GAF Automatic	1985	009-475	009-503
GS450LD	1983	009-475	009-503
GS450LF/LG/LH/LJ	85-88	009-475	009-503
GS450TX/TZ	81-82	009-475	009-503
GS450TXZ/TXD	82-83	009-475	009-503
GS550ES3/ESE/EF/ESF/ESG	83-86	009-475	009-503
GS550LT	1980	—	009-504
GS550LX/LZ	81-82	009-475	009-503
GS550LF/LG	85-86	009-475	009-503
GS550MZ Katana	1982	009-475	009-503
GS550TX	1981	009-475	009-503
GSF600ST/SV/SW/SX/SY Bandit	96-00	009-435	009-506
GSF600SK1/SK2/SK3 Bandit	01-03	009-435	009-506
GSX600FJ-FV Katana	88-97	009-437	009-508
GSXR600WN/WP	92-93	009-480	009-504
GSX-R600W/WX/Y	97-00	009-455	009-507
GR650D/XD Tempter	1983	009-475	009-503
GS650EX/EZ	81-82	009-475	009-503
GS650GX/GZ/GD	81-83	009-475	009-503
GS650GLX/GLZ/GLD	81-83	009-475	009-503
GS650MD Katana	1983	009-475	009-503
GS700EF/ESF	1985	009-475	009-503
GS750B/C/EC/N/EN	77-79	009-479	009-504

# Fuel Petcock Repair Kits

## Suzuki Street

Model	Year	Fuel Petcock Repair Kit	Diaphragm Only
GS750ET	1980	————	009-504
GS750EX/EZ/ED/ESD	81-83	009-475	009-503
GS750LT	1980	————	009-504
GS750LX	1981	009-475	009-503
GS750SD Katana	1983	009-475	009-503
GS750TZ/TD	82-83	009-475	009-503
GSX750FK-FV Katana	89-97	009-437	009-508
GSX-R750RG	1986	009-475	009-503
GSX-R750G/H	86-87	009-475	009-503
GSX-R750J/K/L/M/N	88-92	009-480	009-504
GSX-R750WP	1993	009-480	009-504
GSX-R750TV	96-97	009-455	009-507
GS850GN/GT/GX	79-81	009-479	009-504
GS850GLT	1980	————	009-504
GS850GLX/GLZ/GLD	81-83	009-475	009-503
GS1000C/EC/N/EN/SN	78-79	009-479	009-504
GS1000ET	1980	————	009-504
GS1000GT/GX	80-81	009-479	009-504
GS1000GLT	1980	————	009-504
GS1000GLX	1981	009-475	009-503
GS1000ST	1980	————	009-504
GS1000SZ	1982	009-475	009-503
GS1100ET	1980	————	009-504
GS1100EX/EZ/ED/ESD	81-83	009-475	009-503
GS1100GZ/GLZ/GD/GLD	82-83	009-475	009-503
GS1100GKZ/GK2/GKD/GKE	82-84	009-475	009-503
GS1100LT	1980	————	009-504
GS1100SD Katana	1983	009-475	009-503
GSX1100FJ/FK/FL/FM/FN/FP Katana	88-93	009-440	009-509
GSX-R1100G/H/J	86-88	009-475	009-503
GSX-R1100K/L/M/N	89-92	009-480	009-504
GSX-R1100WP/WR	93-94	009-480	009-504
GS1150ES3/ESE/EF/ESF	83-85	009-475	009-503
GSF1200SV/SAV/SW/SX/SY Bandit	97-00	009-435	009-506

## Suzuki Dual Sport & Offroad

DR250L/M/N/P Offroad	90-93	009-424	————
DR250SEP/SER/SES Dual Sport	93-95	009-427	————
DR350L-X Offroad	90-99	009-424	————
DR350SP-SEX Dual Sport	93-99	009-427	————

## Yamaha Street

SR250G/H/J Exciter	80-82	009-402	009-501
SR250TH Exciter	1981	009-402	009-501
XS360C/D/2D	76-77	009-400	009-504
XS400D	1977	009-400	009-504
XS400E/F/2F/G/H	78-81	009-403	009-500
XS400SG/SH Special	80-81	009-403	009-500
XS400J/K Maxim	82-83	009-402	009-501
XS400RJ/RK Seca	82-83	009-402	009-501
SR500E/F/G/H	78-81	009-400	009-504
XS500E	1978	009-400	009-504
XV535A/AC Virago	1990	009-443	————
XV535E/EC-L/LC Virago	93-99	009-443	————
XV535SF/SFC-SJ/SJC Virago	94-97	009-443	————
XJ550H/J/K Maxim	81-83	009-402	009-501
XJ550RH/RJ/RK Seca	81-83	009-402	009-501
XZ550RJ/RK Vision	82-83	009-402	009-501
FJ600L/LC/N/NC	84-85	009-402	009-501
FZ600S/SC/T/TC/U/UC	86-88	009-427	009-506
FZR600W/WC/A/AC*	89-90	009-424	————
FZR600RA/RAC-RL/RLC*	90-99	009-424	————
SRX600S/SC	1986	009-402	009-501

## Yamaha Street

Model	Year	Fuel Petcock Repair Kit	Diaphragm Only
XJ600SD/SDC-SK/SKC Seca II	92-98	009-445	009-506
XJ650G/H/J/K Maxim	80-83	009-402	009-501
XJ650LH Midnight Maxim	1981	009-402	009-501
XJ650RJ Seca	1982	009-402	009-501
XS650E	1978	009-400	009-504
XS6502F	1979	009-403	009-500
XS650G/H Special II	80-81	009-403	009-500
XS650SH/SJ/SK Heritage	81-83	009-403	009-500
XJ700N/NC/S/SC Maxim	85-86	009-403	009-500
XJ700XN/XNC/XS/XSC Maxim X	85-86	009-403	009-500
XV700L/LC/N/NC Virago	84-85	009-402	009-501
XV700CS/CSC/CT/CTC Virago	86-87	009-402	009-501
XV700SS/SSC Virago	1986	009-402	009-501
XJ750RH/RJ/RK Seca	81-83	009-402	009-501
XS750D/2D/E/F	77-79	009-400	009-504
XS750SE after frame no. 311211	1978	009-403	009-500
XS750SF	1979	009-403	009-500
XV750H/J/K Virago	81-83	009-402	009-501
XV750MK Midnight Virago	1983	009-402	009-501
XV750U/UC-K1/KC1 Virago	88-98	009-442	————
XS850SG/SH Special	80-81	009-403	009-500
XJ900RK Seca	1983	009-403	009-500
XV920J/K Virago	82-83	009-402	009-501
XV920MK Midnight Virago	1983	009-402	009-501
XV920RH/RJ/RK	81-83	009-402	009-501
XS1100E/F/G/H	78-81	009-400	009-504

## Yamaha ATV

YF60S Moto-4	1985	009-424	————
YT60L/N Tri-Zinger	84-85	009-424	————
YFM80N/S/T/U Moto-4	85-88	009-424	————
YFM80D/E/F/G/H Moto-4	92-96	009-424	————
YFM80J/K/L/M/MC/N/NC Badger	97-01	009-424	————
YFM80WP/WR/WS Raptor	02-04	009-424	————
YFM80RT Raptor RT/ RV	05-06	009-424	————
YFM100T/U/W/A/B Champ	87-91	009-424	————
YFA1W/A/B/D/E/F/G/H/J Breeze	89-97	009-424	————
YFA1K-S/SC Breeze	98-04	009-424	————
YFM125S/GT Grizzly 125	04-05	009-424	————
YFM125GHT Grizzly 125 Hunter	2005	009-424	————
YFM200N Moto-4	1985	009-424	————
YFM200DXS/DXT/DXU/DXW Moto-4	86-89	009-424	————
YFS200U/W/A/B/D/E/F/G Blaster	88-95	009-424	————
YFS200H/J/K/L/M/N Blaster	96-01	009-424	————
YFS200P/R/S/T/V Blaster	02-06	009-424	————
YTM200K/L/N Tri-Moto	83-85	009-424	————
YTM200EK/EL Tri-Moto	83-84	009-424	————
YTM200ERN Tri-Moto	1985	009-424	————
YFM225S/T/U Moto-4	86-88	009-424	————
YTM225DXK/DXL/DXN Tri-Moto	83-85	009-424	————
YTM225DRN/DRS Tri-Moto	85-86	009-424	————
YFU1W (230cc) Pro-Hauler	1989	009-424	————
YFU1TW (230cc) Pro-Hauler	1989	009-424	————
YFB250D/E/F/G/H Timberwolf	92-96	009-424	————
YFB250UH/UJ/UK Timberwolf	96-98	009-424	————
YFB250FWF/FWG/FWH Timberwolf	94-96	009-424	————
YFB250D/E/F/G/H Timberwolf	92-96	009-424	————
YFB250UH/UJ/UK Timberwolf	96-98	009-424	————
YFB250FWF/FWG/FWH Timberwolf	94-96	009-424	————
YFB250FWJ/FWK Timberwolf	97-98	009-424	————
YFB250FWL/FWM Timberwolf 4WD	99-00	009-424	————

Yamaha applications with an asterisk \* may require longer bolts



## Yamaha ATV

Model	Year	Fuel Petcock Repair Kit	Diaphragm Only
YFM250W/A/B Moto-4	89-91	009-424	_____
YFM250XL/XLC/XM/XMC Beartracker	99-00	009-424	_____
YFM250XN/XP Beartracker 2WD	01-02	009-424	_____
YFM250XHN Beartracker Real Tree Hunter	2001	009-424	_____
YFM250XHP Bear Tracker	2002	009-424	_____
YFM350ERT/ERU/ERW/ERA Moto-4	87-90	009-424	_____
YFM350ERD/ERE/ERF/ERG Moto-4	92-95	009-424	_____
YFM350FWT-FWJ Big Bear	87-97	009-424	_____
YFM350FWBJ/FWBK/FWBKC Big Bear 4x4	97-98	009-424	_____
YFM350FWBL/FWBLC Big Bear 4WD	1999	009-424	_____
YFM350FHL/FHLC Big Bear 4WD Hunting	1999	009-424	_____
YFM350FXG/FXH/FXJ/FXK Wolverine	95-98	009-424	_____
YFM350FXL/FXLC/FXM/FXMC	99-00	009-424	_____
YFM350FXN/FXNC Wolverine	2001	009-424	_____
YFM350S/T Raptor 350	04-05	009-424	_____
YFM350UH/UJ/UK/UL/ULC Big Bear 2WD	96-99	009-424	_____
YFM350XT-XS/XSC Warrior	87-04	009-424	_____
YFZ350T-T Banshee	87-05	009-424	_____
YFZ350LES Banshee Limited Edition	2004	009-424	_____
YFZ350SET Banshee SE	2005	009-424	_____
YFM400FWE-FWJ Kodiak	93-97	009-424	_____
YFM400FWK/FWL/FWLC Kodiak	98-99	009-424	_____
YFM400FVN Buckmaster 4WD	00-01	009-424	_____
YFM400NM/NMC/NN/NHN Big Bear 2WD	00-01	009-424	_____
YFM600FWAK/FWAL/FWALC Grizzly	98-99	009-424	_____
YFM600FWAM/FWAMC Grizzly	2000	009-424	_____
YFM600HM/HMC Grizzly Hunting	2000	009-424	_____
YFM600FWAN/FWAHN	2001	009-424	_____
Grizzly Hunter Edition			
YFM660FHP Grizzly Hunter Edition	2002	009-424	_____
YFM660FP/FPS/FR/FS Grizzly 600	02-04	009-424	_____
YFM660FHRWL Grizzly Wetlands	2003	009-424	_____
YFM660FHRH Grizzly Real Tree HH	2003	009-424	_____
YFM660FRGY Grizzly 660 4x4 Metallic	2003	009-424	_____
YFM660RN/RNC/RP/RR/RS Raptor	01-04	009-424	_____
YFM660RT Raptor 660	2005	009-424	_____
YFM660RBP Raptor Limited Edition	2002	009-424	_____
YFM660RLER/RLES Limited Edition	03-04	009-424	_____
YFM660RSET Raptor 660 SE	2005	009-424	_____

## Yamaha Dual Sport & Offroad

PW80E-T Y-Zinger	93-05	009-424	_____
YZ80E1/F1/G1/H1/J1/K1/L1/M1/N1	93-01	009-424	_____
YZ85P/R/S/T	02-05	009-424	_____
TT90RM/RMC Offroad	2000	009-424	_____
TT-R90N/P/R/S/ES/ET Offroad	01-05	009-424	_____
RT100A Offroad	1990	009-424	_____
RT100D/E/F/G/H/J/K/L/M	92-00	009-424	_____
TT125RM/RMC	2000	009-424	_____
TT-R125LWM/N/LN/P/LPC	00-02	009-424	_____
TT-R125ER/ES/ET	03-05	009-424	_____
TT-R125LR/LER/LS/LES/LT/LET	03-05	009-424	_____
YZ125D1/E1/F1/G1/H1/K1	92-98	009-424	_____
YZ125L/M/N/P/R/S1/T1	99-05	009-424	_____
TW200B/BC-T1/T1C Trailway	91-05	009-424	_____
TT225L/LC/RM/RMC	99-00	009-424	_____
TT-R225N/NC/P/PC/R/RC/S/SC	01-04	009-424	_____
XT225D/DC-T/TC Serrow (Dual)	92-05	009-424	_____
TT-R230T/TC	2005	009-424	_____
TT-R250N/NC-T/TC	01-05	009-424	_____
WR250ZD/ZE/ZF/ZG/ZH/ZJ Offroad	92-97	009-424	_____
WR250FN/FP/FR/FS	01-04	009-424	_____
YZ250E1/F1/G1/H1/J1/K1	93-98	009-424	_____

## Yamaha Dual Sport & Offroad

Model	Year	Fuel Petcock Repair Kit	Diaphragm Only
YZ250L/M/N/P/R/S1/T1	99-05	009-424	_____
YZ250FP/FR/FS/FT Offroad 4-Stroke	02-05	009-424	_____
XT350F/FC-M/MC Dual Sport	94-00	009-424	_____
YZ400FK/FL Offroad 4-stroke	98-99	009-424	_____
WR400FK/FL/FM Offroad 4-stroke	98-00	009-424	_____
WR426FN/FP Offroad 4-stroke	01-02	009-424	_____
YZ426FN/FP Offroad 4-stroke	01-02	009-424	_____
WR450FR/FS/FT	03-05	009-424	_____
YZ450FR/FS/FT	03-05	009-424	_____
WR500ZD/ZE	92-93	009-424	_____



### Quick Disconnect Inline Fuel Couplers

For quick disconnections between tanks, pumps, filter and carbs. Two types available, single straight-thru and shut-off.

Description	Order No.
Straight-Thru, no-shut-off with 5/16" fuel line fitting	009-170
Shut-off with 5/16" fuel line fitting	009-171



950-700



950-701



### Motion Pro Inline Fuel Valves

Ideal for use on ATV's and other vehicles where inline fuel control is necessary. Not recommended for engines above rate size. Sold each.

Description	Order No.
Inline Fuel Valve for 3/16" I.D. Fuel Valve, up to 200cc	950-700
Inline Fuel Valve for 5/16" I.D. Fuel Valve, up to 300cc	950-701
Inline Fuel Valve for 1/4" I.D. Fuel Valve, up to 300cc	950-702
Inline Fuel Valve with 1/4" threaded pipe and 1/4" barb end	950-707



### K&N Fuel Line "T" Sold each

High flow, durable, lightweight, easy to use. One size fits 1/4" to 3/8" I.D. hose. Color: Black, Height: 0.999 in (25 mm), Length: 1.575 in (40 mm), Material Used: Plastic

Order No. 81-0270

VINTAGE  
INTAKE  
ENGINE  
SUSPENSION  
CONTROL  
ELECTRICAL  
CHEMICAL  
TOOLS  
WATERCRAFT

# Fuel Filters & Fuel Line Fittings



## 90° Angle Fuel Filters

Description	Order No.
1/4" fitting x 1.7" body (sintered bronze element)	009-215
1/4" fitting x 2" body (micron bronze insert)	009-216
1/4" fitting x 2.2" body (micron poly screen)	009-217



## Motion Pro Fuel Line Fittings Kit

This Fuel Line Fittings Kit contains a wide selection of Y and T fittings, hose clamps, o-clips and O-clip Pincher tool in an ABS plastic case. Ideal for the shop mechanic. Individual replacement parts are available to replenish the kit.

Order No. **950-462**



## Fuel Filters

"Economical, high quality, see through design."

### Street Filters- Sintered Bronze Element

Description	Order No.
1/4" fitting x 2" body "Slim Line"	009-200
1/4" fitting x 3" body "High Capacity"	009-202

### Competition Filters- Stainless Steel Element

Description	Order No.
3/16" fitting x 1.13" diameter	009-205
1/4" fitting x 1.3" diameter	009-210
5/16" fitting x 1.5" diameter	009-212



## Aluminum Body Fuel Filters

Super short polished aluminum body with cleanable bronze element

Description	Order No.
5/16" fitting, single inlet, single outlet	009-220
5/16" fitting, double inlet, double outlet	009-221



## Steel O-Clip Pincer Tool

Used to install and remove O-clips, PVC coated grip.

Order No. **950-774**



## Sudco Fuel & Vacuum Hose Clips

OEM sized fuel and vacuum hose clips. Sold pk/5.

**Made in Japan.**

Description	Order No.
1/4" (6mm) I.D.	009-090
9/32" (7mm) I.D.	009-091
5/16" (8mm) I.D.	009-092
3/8" (9mm) I.D.	009-093



## Brass T-Fittings *Sold each*

Description	Order No.
1/4" Brass Fuel T	009-100
3/8" Brass Fuel T	009-102
.17" Brass Fuel T	009-101



## Motion Pro® Premium (Tygon) Fuel Hose

These premium quality fuel lines from Motion Pro are resistant to swelling, hardening, direct sunshine, and cracking. Flexible in temperatures -35° F to + 165° F. Stretches easily over most common motorcycle fuel fittings or petcocks. **Made in the U.S.A.** Sold pre-cut foot or cut to length.

**Not for fuel with greater than 10% methanol/alcohol content.**

Description	Order No.
Gray 3/16" (5mm) I.D.	009-029
Gray 1/4" (6mm) I.D.	009-030
Gray 5/16" (8mm) I.D.	009-031
Clear 3/16" (5mm) I.D.	009-040
Clear 1/4" (6mm) I.D.	009-041
Clear 5/16" (8mm) I.D.	009-042

## Yellow Tygon Fuel Hose

Sold pre-cut foot or cut to length.

**Not for fuel with greater than 10% methanol/alcohol content.**

Description	Order No.
3/16" (5mm) I.D. Yellow	009-034
1/4" (6mm) I.D. Yellow	009-035



## Polyurethane Fuel, Vent Hose & Primer Hose

Sold pre-cut foot or cut to length.

**Not for fuel with greater than 10% methanol/alcohol content.**

Description	Order No.
Red 1/4" ID x 3/8" OD	009-070R
Red 5/16" ID x .473" OD	009-071R
Red 3/8" ID x 9/16" OD	009-072R
Yellow 1/4" ID x 3/8" OD	009-070Y
Yellow 5/16" ID x .473" OD	009-071Y
Yellow 3/8" ID x 9/16" OD	009-072Y
Blue 5/16" ID x .473" OD	009-071B
Blue 3/8" ID x 9/16" OD	009-072B
Green 5/16" ID x .473" OD	009-071G
Green 3/8" ID x 9/16" OD	009-072G
Clear 5/16" ID x .473" OD	009-071C
Clear 3/8" ID x 9/16" OD	009-072C



## Stainless Steel Hose Protectors

Protection for fuel hose. Sold each. **Hose not included.**

Description	Order No.
1-1/2" Diameter	009-085
1.0" Diameter	009-086
7/16" Diameter	009-087
3/8" Diameter	009-088



## Polyurethane Fuel, Vent Hose & Primer Hose

Sold pre-cut foot or cut to length.

**Not for fuel with greater than 10% methanol/alcohol content.**

Description	Order No.
Blue Vent Hose 6/32" (4mm) I.D.	009-005
Blue Primer Hose 1/8" (3mm) I.D.	009-010
Purple Fuel Hose 1/4" (6mm) I.D.	009-015
Blue Fuel Hose 1/4" (6mm) I.D.	009-020
Clear Fuel Hose 1/4" (6mm) I.D.	009-021
Black (Opaque) Fuel Hose 1/4" (6mm) I.D.	009-022



## Sudco Gray Fuel Hose with Red Stripe

Kitaco brand fuel hose, gray with red stripe. Highest quality fuel hose available. This hose is found on many ATV, motocross and offroad Keihin carburetors. Sold pre-cut only, 1 meter length. **Made in Japan.**

**Not for fuel with greater than 10% methanol/alcohol content.**

Description	Order No.
5/32" (3.5mm) I.D.	009-060M
7/32" (5mm) I.D.	009-061M
9/32" (7mm) I.D.	009-062M
5/16" (8.0mm) I.D.	009-063M



## Keihin Clear Pink Overflow Hose

Sold pre-cut foot only.

Genuine (Plas-Tech) replacement hose. This hose is found on many ATV, motocross and offroad Keihin carburetors. **Made in Japan.**

Description	Order No.
1/8" (3mm) I.D. Keihin No. 95003-05033	018-538



## Mikuni Clear Pink Overflow Hose

Sold pre-cut foot only.

Description	Order No.
1/8" (3mm) I.D. Mikuni No. VM14/49	002-755



## Mikuni Black Vent Hose

Sold pre-cut foot only.

Description	Order No.
6/32" (4mm) I.D. Mikuni No. 888-24011	002-478

# Air Filters



005-192

## K&N OE Replacement Air Filters

K&N replacement air filters are designed to fit right into your stock airbox. Pre-oiled and ready for installation. Filters can be cleaned and reused again and again. K&N's unique accordion screen/fabric grid design will supply more air. Increased air flow means increased engine performance. **Made in the USA.** Sold each.

### Ducati

Model	Year	K&N No.	Order No
600SS	91-99	DU-0900	005-192
M600 Monster	93-01	DU-0900	005-192
620 Sport	2003	DU-9098	005-665
750 Paso	87-88	DU-0900	005-192
750SS	91-98	DU-0900	005-192
750SS	1999	DU-9098	005-665
750SS	2002	DU-9098	005-665
M750 Monster	1996	DU-9098	005-665
M750 Monster	97-98	DU-0900	005-192
M750 Monster	99-01	DU-9098	005-665
Monster 750 Dark	99-00	DU-9098	005-665
800 Sport	2003	DU-9098	005-665
800SS	03-05	DU-9098	005-665
900 Super Light	91-97	DU-0900	005-192
900SS	91-98	DU-0900	005-192
900SS	1999	DU-9098	005-665
900SS FE	1998	DU-0900	005-192
900SS I.E.	00-01	DU-9098	005-665
900SS I.E.	2002	DU-0900	005-192
Monster 900	93-98	DU-0900	005-192
Monster 900	99-00	DU-9098	005-665
Monster 900 City	1999	DU-9098	005-665
Monster 900 Cromo	1999	DU-9098	005-665
Monster 900 Cromo	00-01	DU-0900	005-192
Monster 900 Dark	2000	DU-9098	005-665
Monster 900 Dark I.E.	2002	DU-9098	005-665
Monster 900 I.E.	00-02	DU-9098	005-665
Monster M900S	99-00	DU-9098	005-665
ST4 916	99-03	DU-9098	005-665
ST2 944	97-03	DU-9098	005-665
ST3 992	04-05	DU-9098	005-665
ST4S 996	01-05	DU-9098	005-665
1000SS	03-05	DU-9098	005-665

### Harley-Davidson®

XL883C Sportster Custom	2003	HD-1388	005-378
XL883R Sportster	02-03	HD-1388	005-378
XLH883 Sportster Custom	99-02	HD-1388	005-378
XLH883 Sportster	88-03	HD-1388	005-378
XLH883 Sportster Deluxe	88-95	HD-1388	005-378
XLH883 Sportster Hugger	88-03	HD-1388	005-378
XLH883R Sportster	2000	HD-1388	005-378
XLH1200 Sportster	88-02	HD-1388	005-378
1340 FLH Electra Glide Special	1984	HD-2084	005-382
1340 FLHS	1984	HD-2084	005-382
1340 FLHTC Electra Glide Classic	84-85	HD-2084	005-382
1340 FLHX	1984	HD-2084	005-382

### Honda

CBR600F3 Hurricane	95-98	HA-6095	005-370
CBR600F4i Hurricane	01-05	HA-6001	005-706
CBR600RR	03-05	HA-6003	005-707
CB700SC Nighthawk	84-86	HA-7084	005-372
CB750A Automatic	76-78	HA-0100	005-357
CB750C Custom	80-82	HA-1079	005-362
CB750F Super Sport	75-78	HA-0100	005-357
CB750F Super Sport	79-82	HA-1079	_____
CB750K0/K1-K5	69-75	HA-0100	005-357
CB750 K	76-78	HA-0100	005-357
CB750K	79-82	HA-1079	_____
CB750L LTD	1979	HA-1079	_____
CB750SC Nighthawk	82-83	HA-1079	_____
VT750 Shadow ACE Deluxe	98-00	HA-7500	005-708
VT750 Shadow ACE Deluxe	01-03	HA-7500	005-708
VT750 Shadow Deluxe	98-01	HA-7500	005-708
VT750 Shadow Spirit	98-03	HA-7500	005-708
VFR750F	90-97	HA-0003	005-356
VFR800 Interceptor	02-05	HA-8098	005-710
VFR800A (ABS) Interceptor	02-05	HA-8098	005-710
VFR800FI Interceptor	98-01	HA-8098	005-710
CB900C Custom	80-82	HA-1079	_____
CB900F Super Sport	81-82	HA-1079	_____
CBR900RR	93-99	HA-9092-A	005-376
CBR929RR	00-01	HA-9200	005-711
CBR954RR	02-03	HA-9502	005-712
CB1000C Custom	1983	HA-1079	_____
CB1100F Super Sport	1983	HA-1079	_____
CBR1100X Blackbird	97-98	HA-1197	005-613
ST1100	91-02	HA-1191	005-702
ST1100A (ABS)	92-02	HA-1191	005-702
GL1200 Goldwing	1984	HA-8084	005-374
GL1200A Goldwing Aspencade	84-87	HA-8084	005-374
GL1200I Goldwing Interstate	84-87	HA-8084	005-374
GL1500 Goldwing	88-90	HA-8088	005-709
GL1500A Aspencade	91-00	HA-8088	005-709
GL1500I Interstate	91-96	HA-8088	005-709
GL1500SE Goldwing SE	90-00	HA-8088	005-709
GL1500C Valkyrie	97-01	HA-1596	005-704
GL1500CF Valkyrie Interstate	99-01	HA-1596	005-704
GL1500CT Valkyrie Tourer	97-00	HA-1596	005-704
GL1800 Goldwing	01-05	HA-1801	005-705
GL1800A Goldwing	01-05	HA-1801	005-705
VTX1800	02-03	HA-1802	_____

### Kawasaki

EX500A1-A7	87-93	KA-5087	005-559
EX500D1/D2/D3 Ninja 500	94-96	KA-5087	005-559
EX500D4-D12 Ninja 500R	97-05	KA-5087	005-559
EX500D6F Ninja 500R	2006	KA-5087	005-559
H1/A/B/C/D/E/F-500	69-75	KA-1000	005-351
KZ550H1/H2 GPz	82-83	KA-1700	_____
ZX600E1-E10 Ninja ZX-6	93-02	KA-6093	005-393
ZX600E11/E12 ZZR600	03-04	KA-6093	005-393
ZX600F1/F2/F3 Ninja ZX-6R	95-97	KA-6095	005-395
ZX600K1 Ninja ZX-6RR	2003	KA-6003	005-716
ZX600M1 Ninja ZX-6RR	2004	KA-6003	005-716
ZX636B1/B2 Ninja ZX-6R	03-04	KA-6003	005-716
H2/A/B/H2C-750 Mach IV	72-75	KA-1100	005-554
ZX750L1/L2/L3 Ninja ZX-7	93-95	KA-0007	005-391
ZX750M1/M2 Ninja ZX-7R	93-94	KA-0007	005-391
ZX750N1 Ninja ZX-7RR	1996	KA-7596	005-718
ZX750P1-P8 Ninja ZX-7R	96-03	KA-7596	005-718
VN800A1-A11 Vulcan 800	95-05	KA-8095	005-719
VN800B1-B10 Vulcan 800 Classic	96-05	KA-8095	005-719
VN800C2 Vulcan 800 Drifter	2000	KA-8095	005-719
VN800E1-E6F Vulcan 800 Drifter	01-06	KA-8095	005-719
Z1/A/B-900	73-75	KA-0800	005-350
ZX900B1/B2/B3/B4 Ninja ZX-9R	94-97	KA-9094	005-672
KZ1000J1/J2/J3	81-83	KA-1600	005-557

## Kawasaki

Model	Year	K&N No.	Order No.
KZ1000K1/K2 LTD	81-82	KA-1600	<b>005-557</b>
KZ1000M1/M2 CSR	81-82	KA-1600	<b>005-557</b>
KZ1000P1-P21 Police	82-02	KA-1600	<b>005-557</b>
KZ1000P24 Police	2005	KA-1600	<b>005-557</b>
KZ1000R1/R2 Replica	82-83	KA-1600	<b>005-557</b>
ZX1000C1/C2 Ninja ZX-10R	04-05	KA-1004	<b>005-713</b>
KZ1100A1/A2/A3 Shaft	81-83	KA-1600	<b>005-557</b>
KZ1100D1/D2 Spectre	82-83	KA-1600	<b>005-557</b>
KZ1100L1 LTD	1983	KA-1600	<b>005-557</b>
ZX1200A1-A6 Ninja ZX-12R	00-05	KA-1299-1	<b>005-714</b>
VN1500D1/D2 Vulcan 1500 Classic	96-97	KA-1596	<b>005-715</b>
VN1500E1-E5 Vulcan Classic	98-02	KA-1596	<b>005-715</b>
VN1500G1/G1A/G2A Vulcan Nomad	99-00	KA-1596	<b>005-715</b>
VN1500J1/J2 Vulcan Drifter	99-00	KA-1596	<b>005-715</b>
VN1500L1-L3 Vulcan Nomad F.I.	00-02	KA-1596	<b>005-715</b>
VN1500N1-N3 Vulcan Classic F.I.	00-02	KA-1596	<b>005-715</b>
VN1500R1/R2 Vulcan Drifter	01-02	KA-1596	<b>005-715</b>

## Suzuki

GS500EK-EK2	89-02	SU-5589	<b>005-568</b>
GS500FK4/FK5	04-07	SU-5589	<b>005-568</b>
GSF600T/V/W/X Bandit	96-99	SU-7593	<b>005-580</b>
GSF600Y/K1/K2/K3 Bandit	00-03	SU-6000	<b>005-732</b>
GSX600FJ-FK6 Katana	88-06	SU-7592	<b>005-579</b>
GSX-R600WN/WP	92-93	SU-7593	<b>005-580</b>
GSX-R600V/W/X/Y (CA & USA models)	97-00	SU-7596	<b>005-345</b>
GSX-R600K1/K2/K3	01-03	SU-7500	<b>005-734</b>
GSX-R600K4/K5	04-05	SU-7504	<b>005-735</b>
DL650K4/K5/K6/K7 V-Storm	04-07	SU-1002	<b>005-729</b>
SV650X/Y/K1/K2	99-02	SU-6599	<b>005-639</b>
SV650K3/K4/K5/K6/K7	03-07	SU-6503	<b>005-733</b>
SV650SX/SY/SK1/SK2	99-02	SU-6599	<b>005-639</b>
SV650SK3/SK4/SK5 /SK6/SK7	03-07	SU-6503	<b>005-733</b>
GSX750F Katana	89-06	SU-7592	<b>005-579</b>
GSX-R750WP/WR/WS	93-95	SU-7593	<b>005-580</b>
GSX-R750T/V/W/X	96-99	SU-7596	<b>005-345</b>
GSX-R750Y/K1/K2/K3	00-03	SU-7500	<b>005-734</b>
GSX-R750K4/K5	04-05	SU-7504	<b>005-735</b>
Boulevard C50 800	05-08	SU-8001	<b>005-748</b>

## Suzuki

Model	Year	K&N No.	Order No.
VL800 Intruder	01-05	SU-8001	<b>005-748</b>
DL1000K2/K3/K4/K5 V-Storm	02-05	SU-1002	<b>005-729</b>
GSX-R1000K1/K2/K3/K4	01-04	SU-7500	<b>005-734</b>
SV1000K3/K4	03-04	SU-6503	<b>005-733</b>
SV1000SK3/SK4/SK5	03-05	SU-6503	<b>005-733</b>
TL1000RW/RX/RV/RK1/RK2/RK3	98-03	SU-1098	<b>005-670</b>
GSX1100FJ-FP Katana	88-93	SU-7592	<b>005-579</b>
GSX-R1100WP/WR/WS/WT/WV/WW	93-98	SU-7593	<b>005-580</b>
GSF1200SAV/SV-SY Bandit	97-00	SU-7593	<b>005-580</b>
GSF1200SK1-SK5 Bandit	01-05	SU-6000	<b>005-732</b>
GSX1300RX-RK7 Hayabusa	99-07	SU-1399	<b>005-673</b>
VL1500L Intruder	98-04	SU-1598	<b>005-730</b>

## Yamaha

YZF-R6	99-05	YA-6001	<b>005-741</b>
XJ650G/H/J/K Maxim	80-83	YA-1650	<b>005-591</b>
XJ650LH Midnight Special	1981	YA-1650	<b>005-591</b>
XJ650RJ Seca	1982	YA-1650	<b>005-591</b>
XS650C/D/E/F/2F	76-79	YA-1152	—
XS650SE/SF	78-79	YA-1152	—
XVS650L-P/PC V-Star	99-02	YA-6598	<b>005-742</b>
XVS650AK/AKC-AP/APC V-Star Classic	98-02	YA-6598	<b>005-742</b>
XV700L/LC/N/NC Virago	84-85	YA-1186	<b>005-739</b>
XV700CS/CSC/CT/CTC Virago	86-87	YA-1186	<b>005-739</b>
XV700SS/SSC Virago	1986	YA-1186	<b>005-739</b>
XV750 Virago	88-97	YA-1186	<b>005-739</b>
XV1000L/LC/N/NC Virago	84-85	YA-1186	<b>005-739</b>
YZF-R1	99-01	YA-1098	<b>005-637</b>
YZF-R1	02-03	YA-1002	<b>005-736</b>
YZF-R1	04-05	YA-1004	<b>005-737</b>
XV1100 Virago	86-99	YA-1186	<b>005-739</b>
XVZ13 Venture & Venture Royale	86-93	YA-1283	<b>005-587</b>
XVZ1300 Royal Star	96-02	YA-1595	<b>005-740</b>
XVZ1300 Royal Star Tour Deluxe	2000	YA-1595	<b>005-740</b>
XVZ1300 Royal Star Tour Classic	2000	YA-1595	<b>005-740</b>





005-600



005-146



005-700

## K&N ATV OE Replacement Air Filters

K&N ATV air filters boost performance and are ideal for extended use in dusty or off-road racing or riding. Designed to replace your factory air filter. **Made in the USA.** Sold each.

### Honda

Model	Year	K&N Ref.	Order No.	Precharger
ATC250R (clamp-on type)	81-82	RU-1780	005-127	005-452
TRX250R	86-89	HA-4250	005-146	_____
TRX300 Fourtrax 300	88-97	HA-3093	005-645	_____
TRX300 Fourtrax 300	98-00	HA-3098	005-646	_____
TRX350 Rancher	00-05	HA-3500	005-647	_____
TRX350 Rancher 4x4	00-05	HA-3500	005-647	_____
TRX350 Rancher 4x4 ES	00-05	HA-3500	005-647	_____
TRX350 Rancher ES	00-05	HA-3500	005-647	_____
TRX400EX Fourtrax 400EX	99-00	HA-4099	005-625	005-489
TRX400EX Sportrax 400EX	01-05	HA-4099	005-625	005-489
TRX450R	04-05	HA-4504	005-699	_____
TRX500 Foreman	2005	HA-5000	005-649	_____
TRX500 Foreman 4x4	2005	HA-5000	005-649	_____
TRX500 Foreman 4x4 ES	2005	HA-5000	005-649	_____
TRX500 Foreman Rubicon	00-05	HA-5000	005-649	_____
TRX500 Foreman Rubicon	00-05	HA-5000	005-649	_____
GP Scape				
TRX650 Rincon	03-05	HA-5000	005-649	_____
TRX650 Rincon GP Scape	04-05	HA-5000	005-649	_____

### Kawasaki

KSF250A Mojave 250	87-04	KA-2587	005-650	_____
KEF300A1-A6 Lakota 300	95-00	KA-2587	005-650	_____
KEF300B1-B3 Lakota Sport	01-03	KA-2587	005-650	_____
KLF300B1-B17 Bayou 300	88-04	KA-4093	005-652	_____
KLF300C1-C16 Bayou 4x4	89-04	KA-4093	005-652	_____
KVF300A1-A4 Prairie 4x4	99-02	KA-4093	005-652	_____
KVF300B1-B4 Prairie 300	99-02	KA-4093	005-652	_____
KLF400B1-B7 Bayou 4x4	93-99	KA-4093	005-652	_____
KSF400A KFX400	03-05	SU-4002	005-731	_____
KVF400A1/A2 Prairie 4x4	97-98	KA-4093	005-652	_____
KVF400B1 Prairie 400	1998	KA-4093	005-652	_____
KVF400C1-C4 Prairie 4x4	99-02	KA-4093	005-652	_____
KVF400D1-D4 Prairie 400	99-02	KA-4093	005-652	_____

### Suzuki

Model	Year	K&N Ref.	Order No.	Precharger
LT160	2004	SU-1691	005-655	_____
LT-F160	91-01	SU-1691	005-655	_____
LT230EH-EP	87-93	SU-2391	005-656	_____
LT230GEF/GEG	85-86	SU-2391	005-656	_____
LTF230G/H	86-87	SU-2391	005-656	_____
LT-Z400K QuadSport	03-05	SU-4002	005-731	_____
LT-A500	00-01	SU-5098	005-658	_____
LTF500F	98-02	SU-5098	005-658	_____

### Yamaha

YFA1 Breeze	89-04	YA-2088	005-150	_____
YFM125 Grizzly	04-07	YA-2088	005-150	_____
YFS200 Blaster	88-06	YA-2088	005-150	_____
YFM350FX Wolverine	94-05	YA-4350	005-153	_____
YFM350X Warrior	87-04	YA-4350	005-153	_____
YFM350 Raptor	04-07	YA-4350	005-153	_____
YFZ350 Banshee	87-06	YA-3502	005-152	_____
YFM400FW Kodiak	93-99	YA-2597	005-659	_____
YFZ450R	04-07	YA-4504	005-700	005-486
YFM600 Grizzly	97-01	YA-4350	005-153	_____
YFM660 Raptor	01-05	YA-6601	005-743	_____



005-743



005-450



005-452



005-454



005-489

## K&N ATV Precharger

K&N Precharger is a specially designed filter wrap made to extend the service interval of your K&N Air Filter when used in very dusty conditions. Made from durable polyester material containing uniform micron openings. The Precharger will stop dirt particles as small as .500" diameter, yet only adds a 10% restriction to the airflow of the filter. The Precharger is designed to be run dry and can be cleaned with K&N Filter Cleaner. The Precharger is custom made to fit each application. Elastic openings assure that the Precharger will stay in place. Sold each.

### Universal Fit

Description	K&N No.	Order No.
3.5" round x 4" length	RU-0500PK	005-450
3.5" round x 5" length	RU-0510PK	005-452
3.5" round x 6" length	RU-0520PK	005-454
5.5" round x 5" length	22-8016PK	005-489



## Pro-Vents Filtered Airbox Screen

Pro-Vents are easily installed and improve air box breathing. Universal applications. (ATV's, Dual Sport, Offroad) Sold each.

Order No. 005-201





## K&N Custom Clamp On Air Filter Sets

RC oval/chrome end and RU rubber end clamp on filters.  
Fits Keihin and Mikuni carburetors listed.  
Sold each. **Bold Red part numbers are sold in sets.** (pk/2)  
**Made in the USA.**

### Harley- Davidson®

Application	Year	Carburetor	Flange Dimension	Filter Dimension	K&N No.	Order No.
Sportster/Big Twin		VM38, 39, 41	2-7/16" / straight	round / 2"	RC-0850	<b>005-100</b>
		TM38, 39, 41	2-7/16" / straight	round / 2"	RC-0850	<b>005-100</b>
Sportster/Big Twin		VM40-44	2-3/4" / straight	round / 2"	RC-0920	<b>005-101</b>
Sportster/Big Twin		HS40	2-1/8" / offset	round / tapered	_____	<b>007-216</b>
		chrome bonnet for <b>005-216</b>			_____	<b>007-215</b>
XR750/1000		VM38, 41	2-7/16" / 10 °	oval / 7"	RU-1240	<b>005-175</b>
		TM38, 41	2-7/16" / 10 °	oval / 7"	RU-1240	<b>005-175</b>
XR750/1000		VM38, 41	2-7/16" / 20 °	oval / 5"	RU-1370	<b>005-332</b>
		TM38, 41	2-7/16" / 20 °	oval / 5"	RU-1370	<b>005-332</b>

### Honda Street

CBR600F2 (motorcycle only)	91-94	FCR32, 33	2-1/8" / offset	oval / 2-3/4"	RU-3000	<b>005-178</b>
		FCR32, 33	2-1/8" / offset	oval / 2-3/4"	RU-3010	<b>005-179</b>
CBR600F2 (motorcycle & cars)	91-94	FCR32, 33			RU-2852	<b>005-187</b>
CBR900RR	93-99	FCR39,41	2-7/16" / dual	pyramid	RU-2952	<b>005-174</b>

### Honda ATV

ATC90	70-78	VM24-VM28	1-11/16" / 40 °	tapered / 4"	R-1100	<b>005-105</b>
ATC110	79-85	VM24-VM28	1-11/16" / 40 °	tapered / 4"	R-1100	<b>005-105</b>
ATC185/S	80-83	VM24-VM28	1-11/16" / 40 °	tapered / 4"	R-1100	<b>005-105</b>
ATC250R	81-84	VM30-VM34	2-1/4" / straight	round / 4"	RU-0600	<b>005-113</b>
		TM32, TM34	2-1/4" / straight	round / 4"	RU-0600	<b>005-113</b>
ATC250R	81-84	PJ34	2-1/4" / straight	round / 4"	RU-0600	<b>005-113</b>
		TM36, TM38	2-7/16" / straight	round / 4"	RU-0800	<b>005-116</b>

### Honda Offroad

XR185	1979	VM28, TM28	1-11/16" / straight	round / 4"	RU-0200	<b>005-112</b>
XR200	1983	VM28, TM28	1-11/16" / straight	round / 4"	RU-0200	<b>005-112</b>

### Kawasaki Street

ZX600 Ninja ZX-6	88-94	FCR35	2-7/16" / dual	pyramid	RU-2952	<b>005-174</b>
ZX1000B1/B2/B3 Ninja ZX-10	88-90	FCR37, 39, 41	2-7/16" / dual	pyramid	RU-2952	<b>005-174</b>
ZX1100C/DNinja ZX-11*	91-01	FCR37, 39, 41	2-7/16" / dual	pyramid	RU-2952	<b>005-174</b>

(\*mini sprints only\*- ZX1100)

### Kawasaki ATV

KLT200A/B	81-83	VM28, TM28	1-11/16" / straight	round / 4"	RU-0200	<b>005-112</b>
-----------	-------	------------	---------------------	------------	---------	----------------

### Norton

Commando 750/850 (single carb)		VM, TM34	2-1/4" / offset	round / 2-1/2"	RU-0650	<b>005-185</b>
Commando 750/850 (single carb)		VM, TM36, 38	2-7/16" / straight	round / 2"	RC-0850	<b>005-100</b>



## Suzuki

Application	Year	Carburetor	Flange Dimension	Filter Dimension	K&N No.	Order No.
GSX-R750		RS36, 40	2-1/8" / straight	tapered / oval	RC-0981	<b>005-121</b>
		RS36, 40	2-1/8" / straight	tapered / oval	RU-0981	<b>005-744</b>
GSX-R750	93-95	FCR39, 41	2-3/8" / dual	straight / oval	RU-2922	<b>005-184</b>
GSX-R750W (liquid cooled)		FCR37, 39, 41	2-3/8" / dual	straight / oval	RU-3092	<b>005-340</b>
GSX-R1100		RS36, 41	2-1/8" / straight	tapered / oval	RC-0981	<b>005-121</b>
GSX-R1100W (liquid cooled)	93-97	FCR39, 41	2-3/8" / dual	straight / oval	RU-2922	<b>005-184</b>
		FCR37, 39, 41	2-3/8" / dual	straight oval	RU-3092	<b>005-340</b>

## Suzuki ATV

LT230		VM28, TM28	1-11/16" / straight	round / 4"	RU-0200	<b>005-112</b>
LT250		VM, TM, PJ	2-7/16" / 20 °	round / 6"	RU-1770	<b>005-123</b>
		PWK 36-41				

## Triumph

T120, T10, TR6, TR7		VM30, 32, 34 PJ, PWK 36-41	2-1/4" / offset	round / 1"	SU-305	<b>005-111</b>
---------------------	--	-------------------------------	-----------------	------------	--------	----------------

## Yamaha

RD350	73-75	VM, TM 30-34	2-1/4" / straight	round 4"	RU-0600	<b>005-113</b>
		PJ 30-34	2-1/4" / straight	round 4"	RU-0600	<b>005-113</b>
RZ350	84-85	VM, TM 30-34	2-1/4" / straight	round 4"	RU-0600	<b>005-113</b>
		PJ 30-34	2-1/4" / straight	round 4"	RU-0600	<b>005-113</b>
RD400	76-78	VM, TM 30-34	2-1/4" / straight	round 4"	RU-0600	<b>005-113</b>
		PJ 30-34	2-1/4" / straight	round 4"	RU-0600	<b>005-113</b>
FZR400R	88-90	FCR 32-33	2-1/8" / offset	oval / 4"	RC-2890	<b>005-170</b>
		FCR 32-33	2-1/8" / offset	oval / 4"	RC-2900	<b>005-171</b>
FZR600R	89-99	FCR 32-33	2-1/8" / offset	oval / 4"	RC-2890	<b>005-170</b>
		FCR 32-33	2-1/8" / offset	oval / 4"	RC-2900	<b>005-171</b>
FZR750RT/RU	87-88	FCR 37, 39, 41	2-7/16" / straight	round / 4"	RU-0800	<b>005-116</b>
FZR1000RT/RU	87-88	FCR37, 39, 41	2-7/16" / straight	round / 4"	RU-0800	<b>005-116</b>
FZR1000	89-95	FCR37, 39, 41	2-3/8" / straight	oval / 3"	RU-3092	<b>005-340</b>
		FCR37, 39, 41	2-7/16" / straight	round / 5"	RU-0810	<b>005-182</b>

## Yamaha ATV

YTM200 Tri-Moto		VM, TM28-30	1-11/16" / straight	round / 4"	RU-0200	<b>005-112</b>
YFZ350 Banshee	87-06	OEM VM26SS	1-3/4" / 10"	round / 6"	RU-1050	<b>005-124</b>
		OEM VM26SS	1-11/16" / straight	round / 5"	RU-0210	<b>005-318</b>
YFZ350 Banshee	87-06	TM28, PWK28	2-1/16" / 17.5 °	round / 5"	RU-1780	<b>005-127</b>
		TM28, PWK28	2-1/16" / 10 °	round / 6"	RU-1070	<b>005-173</b>
YFZ350 Banshee	87-06	VM30-34	2-1/4" / 5 °	round / 5"	RB-0610	<b>005-310</b>
		TM32-34	2-1/4" / straight	round / 6"	RU-0620	<b>005-320</b>
		PWK33, 35 PJ34				
YFZ350 Banshee	87-06	VM, TM	2-7/16" / straight	round / 6"	RU-3030	<b>005-663</b>
		PJ, PWK39	2-7/16" / straight	round / 4"	RU-0800	<b>005-116</b>

## Karts/ Micro Sprints & Flat Track Bikes

		VM, TM, PJ	2-1/4" / straight	round / 4"	RU-0600	<b>005-113</b>
		PWK 30-35	2-1/4" / 5"	round / 5"	RB-0610	<b>005-310</b>
		PWK 30-35	2-1/4" / 6"	round / 6"	RU-0620	<b>005-320</b>
		VM, TM, PJ	2-7/16" / 20 °	round / 4"	RU-1750	<b>005-176</b>
		PWK 36-41	2-7/16" / 20 °	round / 5"	RU-1760	<b>005-177</b>
		PWK 36-41	2-7/16" / 20 °	round / 6"	RU-1770	<b>005-123</b>
		PWK 36-41	2-7/16" / 10 °	oval / 7"	RU-1240	<b>005-175</b>
		PWK 36-41	2-7/16" / straight	round / 6"	RU-1000	<b>005-328</b>
		PWK 36-41	2-7/16" / 20 °	oval / 5"	RU-1370	<b>005-332</b>
		PWK 36-41	2-7/16" / 20 °	oval / 7"	RU-1390	<b>005-333</b>
		PWK 36-41	2-7/16" / straight	round / 6"	RU-0820	<b>005-114</b>
		PWK 38, 39	2-7/16" / offset	round / 5-1/2" x 4"	RU-0880	<b>005-324</b>
		VM40, 44	2-3/4" / 10 °	round / 6"	RU-1470	<b>005-126</b>



## K&N Custom Clamp On Air Filter Sets

RC oval/chrome end and RU rubber end clamp on filters.  
Use with stock carburetors, airbox removed on models listed.  
Sold in a pk/2, pk/4 and each as indicated. **Made in the USA.**

Qt	Filter Style or Position	Flange Angle	K&N No.	Order No.
Pk/4	Oval	Offset	RC-2454	<b>005-722</b>
Pk/4	Oval	Offset	RC-0984	<b>005-720</b>
Pk/4	Oval	Offset	RC-1824	<b>005-721</b>
Pk/2	Oval	Dual	RU-2922	<b>005-184</b>
			RU-2852	<b>005-187</b>



005-720

### Honda

Application	Year	K&N Ref.	Order No.
CB750C Custom	80-82	RC-0984	<b>005-720</b>
CB750F Super Sport	79-82	RC-0984	<b>005-720</b>
CB750K	79-82	RC-0984	<b>005-720</b>
CB750L LTD	1979	RC-0984	<b>005-720</b>
CB750SC Nighthawk	82-83	RC-0984	<b>005-720</b>
CB900C Custom	80-82	RC-0984	<b>005-720</b>
CB900F Super Sport	81-82	RC-0984	<b>005-720</b>
CB1000C Custom	1983	RC-0984	<b>005-720</b>
CB1100F Super Sport	1983	RC-0984	<b>005-720</b>

### Kawasaki

KZ550H1/H2 GPz	82-83	RC-1824	<b>005-721</b>
ZX550A1/A2 GPz	84-85	RC-1824	<b>005-721</b>
ZL600A1/A2 Eliminator	85-86	RC-1824	<b>005-721</b>
ZL600B2/B3 Eliminator	96-97	RC-1824	<b>005-721</b>
ZX600A1/A2/A3 Ninja 600R	85-87	RC-1824	<b>005-721</b>
ZX600B1 Ninja 600RX	1987	RC-1824	<b>005-721</b>
ZX600C1-C10 Ninja 600R	88-97	RC-1824	<b>005-721</b>
KZ750E1/E2/E3	80-82	RC-1824	<b>005-721</b>
KZ750FI LTD	1983	RC-1824	<b>005-721</b>
KZ750H1/H2/H3/H4 LTD	80-83	RC-1824	<b>005-721</b>
KZ750L3	1983	RC-0984	<b>005-720</b>
KZ750N1/N2 Spectre	82-83	RC-0984	<b>005-720</b>
KZ750R1 GPz	1982	RC-0984	<b>005-720</b>
ZX750A1/A2/A3 GPz	83-85	RC-0984	<b>005-720</b>
Z1/A/B-900	73-75	RC-2454	<b>005-722</b>
KZ900A4/A5	76-77	RC-2454	<b>005-722</b>
KZ900B1 LTD	1976	RC-2454	<b>005-722</b>
KZ1000A1/A2	77-78	RC-2454	<b>005-722</b>
KZ1000A3/A4 MKII	79-80	RC-2454	<b>005-722</b>
KZ1000B1/B2/B3/B4 LTD	77-80	RC-2454	<b>005-722</b>
KZ1000C1-C4 Police	78-81	RC-2454	<b>005-722</b>
KZ1000D1 Z1R	1978	RC-2454	<b>005-722</b>
KZ1000D3 Z1R	1980	RC-2454	<b>005-722</b>
KZ1000E1/E2 Shaft ST	79-80	RC-2454	<b>005-722</b>
KZ1000J1/J2/J3	81-83	RC-0984	<b>005-720</b>
KZ1000K1/K2 LTD	81-82	RC-0984	<b>005-720</b>
KZ1000M1/M2 CSR	81-82	RC-0984	<b>005-720</b>
KZ1000P1-P17 Police	82-99	RC-0984	<b>005-720</b>
KZ1000R1/R2 Replica	82-83	RC-0984	<b>005-720</b>
ZG1000A Concours	86-02	RC-1824	<b>005-721</b>
ZL1000A1 Eliminator	1987	RC-1824	<b>005-721</b>
KZ1100A1/A2/A3 Shaft	81-83	RC-0984	<b>005-720</b>
KZ1100B1/B2 GPz	81-82	RC-0984	<b>005-720</b>
KZ1100D1/D2 Spectre	82-83	RC-0984	<b>005-720</b>
KZ1100L1 LTD	1983	RC-0984	<b>005-720</b>
ZN1100B1/B2 LTD Shaft	84-85	RC-0984	<b>005-720</b>
ZX1100A1/A2 GPz	83-84	RC-2454	<b>005-722</b>

### Suzuki

Application	Year	K&N Ref.	Order No.
GSX600FJ/FK Katana	88-89	RC-1824	<b>005-721</b>
GSX600FL-FK2 Katana	90-02	RU-2922	<b>005-184</b>
GS700EF/ESF	1985	RC-0984	<b>005-720</b>
GS750B/C/EC/N/EN/L	77-79	RC-2454	<b>005-722</b>
GS750ET/EX/EZ	80-82	RC-0984	<b>005-720</b>
GS750ED/ESD	1983	RC-0984	<b>005-720</b>
GS750LT/LX	80-81	RC-0984	<b>005-720</b>
GS750SD Katana	1983	RC-0984	<b>005-720</b>
GS750TZ/TD	82-83	RC-0984	<b>005-720</b>
GSX750FK-FK2 Katana	89-02	RU-2922	<b>005-184</b>
GSX-R750G/RG/H	86-87	RC-1824	<b>005-721</b>
GSX-R750J/K/L/N	88-92	RU-2922	<b>005-184</b>
GS850GT/GLT~GD/GLD	80-83	RC-0984	<b>005-720</b>
GS1000C/EC/N/EN/LN	78-79	RC-2454	<b>005-722</b>
GS1000GT/GLT/GX/GLX	80-81	RC-0984	<b>005-720</b>
GS1000ST	1980	RC-0984	<b>005-720</b>
GS1000SZ Katana	1982	RC-0984	<b>005-720</b>
GS1100ET/EX/EZ/ED	80-83	RC-0984	<b>005-720</b>
GS1100GZ/GLZ/GD/GLD	82-83	RC-0984	<b>005-720</b>
GS1100GKZ/GK2/GKD/GKE	82-84	RC-0984	<b>005-720</b>
GS1100LT	1980	RC-0984	<b>005-720</b>
GS1100SD Katana	1983	RC-0984	<b>005-720</b>
GSX1100FJ~FP Katana	88-93	RC-1824	<b>005-721</b>
GSX-R1100G/H/J	86-88	RC-1824	<b>005-721</b>
GSX-R1100K/L/M/N	89-92	RU-2922	<b>005-184</b>
GS1150ESE/ESF/ESG	84-86	RC-0984	<b>005-720</b>
GS1150EF/EG	85-86	RC-0984	<b>005-720</b>
GS1150ES3/EF2	84-85	RC-0984	<b>005-720</b>
GSF1200SV~SY/SAV Bandit	97-00	RU-2922	<b>005-184</b>

### Yamaha

FZR400R	88-90	RC-1824	<b>005-721</b>
FJ600L/LC/N/NC	84-85	RC-1824	<b>005-721</b>
FZ600S/SC/T/TC/U/UC	86-88	RC-1824	<b>005-721</b>
FZR600R	89-99	RU-2852	<b>005-187</b>
XJ600 Seca II	92-98	RC-1824	<b>005-721</b>
YX600 Radian	86-90	RC-1824	<b>005-721</b>
XJ650G/H/J/K Maxim	80-83	RC-1824	<b>005-721</b>
XJ650LH Midnight Maxim	1981	RC-1824	<b>005-721</b>
FZX700 Fazer	86-87	RC-1824	<b>005-721</b>
XJ700 Maxim	85-86	RC-1824	<b>005-721</b>
XJ750J/K Maxim	82-83	RC-1824	<b>005-721</b>
XJ750 Midnight Maxim	1983	RC-1824	<b>005-721</b>
XJ750RH/RJ/RK Seca	81-83	RC-1824	<b>005-721</b>
XJ900RK Seca	1983	RC-1824	<b>005-721</b>
XJ1100J Maxim	1982	RC-0984	<b>005-720</b>
XS1100F/G/H	79-81	RC-0984	<b>005-720</b>
XS1100LG/LH Midnight Special	80-81	RC-0984	<b>005-720</b>
XS1100SF/SG/SH Special	79-81	RC-0984	<b>005-720</b>



005-749



005-121



005-744



005-140

## K&N Universal Clamp-On Air Filters

K&N Universal Air Filters are designed and manufactured for a variety of applications. Regardless of the angle, offset, or diameter of the air intake, there is probably a K&N Universal air filter available for your equipment. Sold each.

Mounting Flange Inside Dimension	Filter Outside Diameter	Filter Length	Flange Length	Flange Angle	Flange Type	K&N No.	Order No.
1-3/4"	3-1/2"	6"	5/8"	10 °	centered	RU-1050	005-124
2-1/16"	3-1/2"	5"	5/8"	—	centered	RU-0510	005-724
2-1/16"	3-1/2"	6"	5/8"	—	centered	RU-0520	005-725
2-1/16"	3-1/2"	5"	3/4"	10 °	angled	RU-1060	005-726
2-1/8"	3"	4"	5/8"	—	offset	RU-0981	005-744
2-1/8"	3"	4"	5/8"	—	offset	RC-0981	005-121
2-1/4"	3-1/2"	5"	5/8"	—	centered	RU-0610	005-638
2-1/4"	3-1/2"	5"	5/8"	5 °	angled	RB-0610	005-310
2-1/4"	3-1/2"	6"	3/4"	10 °	angled	RU-1090	005-728
2-1/4"	3-1/2"	5"	3/4"	10 °	angled	RU-1080	005-727
1-11/16"	3"	2-3/4"	5/8"	—	centered	RC-1070	005-110
1-11/16"	2"	2-3/4"	5/8"	—	offset	RC-1820	005-140
2-7/16"	3-3/4"	2-3/4"	5/8"	—	centered	RU-2780	005-188
2-1/4"	3"	4-1/2"	5/8"	—	centered	RC-2340	005-749



## K&N Filtercharger® Oil

The only oil specially formulated to work with in combination with the cotton fabric in K&N Filtercharger® elements providing outstanding air filtration. When used as directed, it quickly penetrates the filter pleats, where it remains suspended in the cotton fabric unit until the element is cleaned with K&N Air Filter Cleaner.

Air Filter Oil	K&N No.	Order No.
6-1/2 oz. aerosol can	99-0504	005-530
12 oz. aerosol can	99-0516	005-532
8 oz. squeeze bottle	99-0533	005-534

## Air Filter Cleaner & Degreaser

32 fl. oz. squirt bottle	99-0621	005-520
--------------------------	---------	---------

The only cleaner formulated for K&N Filtercharger® elements. **Note:** Not to be used on polished anodized aluminum.

## K&N Recharger® Filter Care Service Kit

This six step maintenance system is designed to recharge any K&N Filtercharger® Air Filter. It restores air flow efficiency so your Filtercharger® performs like new.

Recharger® Filter Care Service Kit	K&N No.	Order No.
Kit includes 6-1/2 oz. aerosol spray oil, 12 oz. filter cleaner and service decal.	99-5000	005-540

## Recharger® Filter Care Service Kit

Kit includes 8 oz. squeeze oil, 12 oz. filter cleaner and service decal. Same as 005-540 except has squeeze bottle instead of spray can.	99-5050	005-541
--	---------	---------

# Air Filters & Air Filter Gaskets



**PRO-SEAL™**



## PC Racing Flo Air Filters

PC Racing's Flo® X filters have a patent-pending design that includes two Foam Filterskins®. The main filter incorporates a bonded two layer precision foam and proper density for maximum performance. Made with the highest quality materials to last for years.

### Honda

Model	Year	Flo Air Filter No.	Order No.	Pro Seal Gasket No.	Order No.
CR80R	86-02	PCF3X	<b>005-793</b>	PC7	_____
CR85R	03-07	PCF3X	<b>005-793</b>	PC7	_____
CR125R	89-01	PCF1X	<b>005-791</b>	PC1	<b>945-041</b>
CR125R	02-07	PCF1X	<b>005-791</b>	PC16	_____
CR250R	88-01	PCF1X	<b>005-791</b>	PC1	<b>945-041</b>
CR250R	02-07	PCF1X	<b>005-791</b>	PC16	_____
CRF250R	04-09	PCF2X	<b>005-792</b>	PC15	_____
CRF250X	04-09	PCF2X	<b>005-792</b>	PC15	_____
CRF450R	02-08	PCF2X	<b>005-792</b>	PC15	_____
CRF450X	05-09	PCF2X	<b>005-792</b>	PC15	_____
CR500R	89-01	PCF1X	<b>005-791</b>	PC1	<b>945-041</b>

### Kawasaki

KX65	00-11	PCF4X	<b>005-794</b>	PC6	<b>945-046</b>
KX80	91-00	PCF4X	<b>005-794</b>	PC6	<b>945-046</b>
KX85	01-11	PCF4X	<b>005-794</b>	PC6	<b>945-046</b>
KX100	95-11	PCF4X	<b>005-794</b>	PC6	<b>945-046</b>
KX125	87-89	_____	_____	PC9	<b>945-049</b>
KX125	90-91	PCF1X	<b>005-791</b>	PC1	<b>945-041</b>
KX125	94-07	PCF1X	<b>005-791</b>	PC1	<b>945-041</b>
KDX200	89-96	_____	_____	PC9	<b>945-049</b>
KDX220	97-04	_____	_____	PC9	<b>945-049</b>
KDX250	91-94	_____	_____	PC9	<b>945-049</b>
KLX250R	94-96	_____	_____	PC9	<b>945-049</b>
KX250	87-89	_____	_____	PC9	<b>945-049</b>
KX250	90-91	_____	_____	PC1	<b>945-041</b>
KX250	94-07	PCF1X	<b>005-791</b>	PC1	<b>945-041</b>
KX250F	04-05	PCF1X	<b>005-791</b>	PC17	_____
KX250F	06-11	PCF2X	<b>005-792</b>	PC18	<b>945-050</b>
KLX300R	97-07	_____	_____	PC9	<b>945-049</b>
KLX400R	2003	_____	_____	PC9	<b>945-049</b>
KLX450R	08-09	PCF2X	<b>005-792</b>	_____	_____
KX450F	06-11	PCF2X	<b>005-792</b>	PC18	_____
KX500	87-04	_____	_____	PC9	<b>945-049</b>
KLX650R	93-96	_____	_____	PC9	<b>945-049</b>

## PC Racing Pro-Seal™ Air Filter Gasket

PC Racing's Pro-Seal is the answer for a perfect filter to air box seal. Eliminates the use of grease. This neoprene gasket adheres to the rim inside the air box and creates a larger sealing surface. Perfect sealing time after time.

### KTM

Model	Year	Flo Air Filter No.	Order No.	Pro Seal Gasket No.	Order No.
85 SX	04-07	PCF5X	_____	PC5	<b>945-045</b>
125 SX	98-06	PCF5X	_____	PC5	<b>945-045</b>
200	98-07	PCF5X	_____	PC5	<b>945-045</b>
250 SX/SX-F	98-06	PCF5X	_____	PC5	<b>945-045</b>
250 XC/XC-F	98-07	PCF5X	_____	PC5	<b>945-045</b>
250/300	90-97	PCF1X	<b>005-791</b>	PC1	<b>945-041</b>
300	03-07	PCF5X	_____	PC5	<b>945-045</b>
360	96-97	PCF1X	<b>005-791</b>	PC1	<b>945-041</b>
380	98-02	PCF5X	_____	PC5	<b>945-045</b>
400	98-02	PCF5X	_____	PC5	<b>945-045</b>
450 SX/SX-F	03-06	PCF5X	_____	PC5	<b>945-045</b>
450 XC	03-07	PCF5X	_____	PC5	<b>945-045</b>
520 XC	98-02	PCF5X	_____	PC5	<b>945-045</b>
525 XC	98-02	PCF5X	_____	PC5	<b>945-045</b>

### Suzuki

RM65	03-06	PCF4X	<b>005-794</b>	PC6	<b>945-046</b>
RM80	86-01	PCF4X	<b>005-794</b>	_____	_____
RM85	02-11	PCF4X	<b>005-794</b>	_____	_____
RM100	2003	PCF4X	<b>005-794</b>	PC6	<b>945-046</b>
RM125	04-07	PCF1X	<b>005-791</b>	PC3	<b>945-043</b>
RM250	03-08	PCF1X	<b>005-791</b>	PC3	<b>945-043</b>
RMX250	96-99	_____	_____	PC9	<b>945-049</b>
RM-Z250	04-11	PCF1X	<b>005-791</b>	PC17	_____
RM-Z250	2007	PCF1X	<b>005-791</b>	_____	_____
DR-Z400	00-07	_____	_____	PC9	<b>945-049</b>
RMZ450	05-11	PCF1X	<b>005-791</b>	PC3	<b>945-043</b>

### Yamaha

YZ80	93-01	PCF4X	<b>005-794</b>	PC6	<b>945-046</b>
YZ85	02-11	PCF4X	<b>005-794</b>	PC6	<b>945-046</b>
YZ125	93-09	PCF1X	<b>005-791</b>	_____	_____
WR250F	01-07	PCF1X	<b>005-791</b>	_____	_____
YZ250	93-09	PCF1X	<b>005-791</b>	PC3	<b>945-043</b>
YZ250F	01-11	PCF1X	<b>005-791</b>	PC3	<b>945-043</b>
WR400F	98-00	PCF1X	<b>005-791</b>	_____	_____
YZ400F	98-99	PCF1X	<b>005-791</b>	PC3	<b>945-043</b>
WR426F	01-02	PCF1X	<b>005-791</b>	PC3	<b>945-043</b>
YZ426F	00-02	PCF1X	<b>005-791</b>	PC3	<b>945-043</b>
WR450F	01-02	PCF1X	<b>005-791</b>	_____	_____
YZ450F	03-08	PCF1X	<b>005-791</b>	PC3	<b>945-043</b>



## PC Racing Filterskins™

Filterskins are an extremely thin but durable air filter cover. While allowing maximum airflow, an oiled Filterskin will catch 90% of the dirt that tries to pass through the air filter. Between races or between rides, simply pull off a dirty Filterskin and slide on a clean one. Filterskins are extremely elastic and each size will expand over a wide range of air filters sizes. Sold each.

Diameter	Length	Order No.	Applications
3" - 4"	3" - 4"	<a href="#">945-030</a>	Small & short filters, short clamp-on and pod, KX60
3" - 5"	5" - 8"	<a href="#">945-032</a>	Small & tall filters, tall clamp-on and pod, Honda Fourtrax & Pilot, Yamaha Banshee/Warrior.
3" - 5"	5" - 8"	<a href="#">945-032</a>	
5" - 6"	2" - 5"	<a href="#">945-034</a>	Honda XR's & ATC's, Hon/Suz/Yam 80cc MXers, Kaw KLR,
5" - 6"	2" - 5"	<a href="#">945-034</a>	Yam Blaster & Breeze, Suz DR'S & 200-250 Quads
6" - 8"	4" - 7"	<a href="#">945-036</a>	Honda CR's, Kaw KDX/KLX, KX, KTM/91, Suz DRZ, RM, RMX,
6" - 8"	4" - 7"	<a href="#">945-036</a>	LT500 Quad, Yam WR/YZ
		<a href="#">945-038</a>	Quick Release, see <a href="#">945-036</a> , same applications



## Pro-Seal™ Airbox Kits for Honda CR/CRF

In addition to filling the gap between the air filter and airbox, this special Pro-Seal™ is cut around and the same height as the nipples inside the airbox. This creates a perfectly flat sealing surface for the air filter. This flat sealing surface eliminates the tendency that the nipples have of pulling the filter away from the cage when the filter is tightened. The Air Boot Gasket is waterproof and has memory, so it will have the same perfect seal if you take your airbox apart again. The Air Boot plate will not flex or distort and in conjunction with the Air Boot Gasket creates a perfect seal for the lifetime of the motorcycle. Sold as kits, includes the following: 1/4" thick neoprene Pro-Seal™ Air Filter Gasket, 1/8" thick 6061 T6 Red Anodized Air Boot Plate, 1/8" thick neoprene Air Boot Gasket and longer Air Boot Screws.

Application	Order No.
CR125R, CR250R (02-05)	<a href="#">945-060</a>
CRF450R (2002)	<a href="#">945-061</a>

## PC Racing Carburetor Vent Systems

PC Racing's carburetor vent system routes the venting hoses from the carburetor upward to a foam filter equipped vent box inside the airbox. This allows fuel to drain free without hesitation and ensures continual airflow into the carburetor. Prevents fuel from vapor-lock in the standard vent hoses. Another function of the vent system is keeping water out of the vent hose in stream crossings and when washing your bike. Vent Systems are available for single and dual carburetors.

### Carburetor Vent System: Single Carburetor (Black)

Applications: All single carbureted 2 and 4-stroke ATV's, karts, motorcycles, and snowmobiles with motorcycle style carburetors.

Order No. [945-003](#)

### Carburetor Vent System: Dual Carburetor (Blue)

Applications: All dual carbureted 2 and 4-stroke ATV's, karts, motorcycles, and snowmobiles with motorcycle style carburetors. This system works great on Yamaha YFZ350 Banshee.

Order No. [945-010](#)



- Prevents bogging
- Washable filter
- Prevents flooding
- Fits all carburetors
- Velcro-mounted vent box

# Gasket Sets



## Vesrah Engine Gasket Sets

Gasket sets are available in complete and top end sets.

**Made in Japan** to OEM specifications. **Please call for availability.**

### Honda Street

Model	Year	Complete	Top End
XL80S	80-85	<b>608-083</b>	<b>609-083</b>
XL100S	79-85	<b>608-084</b>	_____
CB92 Benley Super Sport 125	59-62	<b>608-140</b>	_____
CB92R Benley Super Racer 125	61-62	<b>608-140</b>	_____
XL200R	83-84	<b>608-070</b>	_____
CB72 Hawk 250	61-66	<b>608-160</b>	_____
CB250	93-07	<b>608-1179</b>	<b>609-5179</b>
CMX250C Rebel	96-12	<b>608-1179</b>	<b>609-5179</b>
CMX250C Rebel	99-12	<b>608-1179</b>	<b>609-5179</b>
CMX250C2 Rebel	99-00	<b>608-1179</b>	<b>609-5179</b>
XL250R Dual Sport	85-87	<b>608-1079</b>	<b>609-5079</b>
XR250L Dual Sport	91-96	<b>608-1079</b>	<b>609-5079</b>
CB77 305 Super Hawk 305	61-68	<b>608-162</b>	_____
CL77 Scrambler 305	65-68	<b>608-162</b>	_____
CB350G	1973	<b>608-012</b>	_____
CB350/K1-K4 Super Sport	68-73	<b>608-012</b>	_____
CL350/K1-K5 Scrambler	68-73	<b>608-012</b>	_____
SL350 Moto Sport	1970	<b>608-012</b>	_____
CB400A Automatic	1978	<b>608-053</b>	_____
CB400F Super Sport	75-77	<b>608-170</b>	_____
CB400T1 Hawk	78-79	<b>608-053</b>	_____
CB400TII Hawk	78-79	<b>608-053</b>	_____
CB400T Hawk	80-81	<b>608-053</b>	_____
CM400A Automatic	79-81	<b>608-053</b>	_____
CM400C Custom	1981	<b>608-053</b>	_____
CM400E	80-81	<b>608-053</b>	_____
CM400T	79-81	<b>608-053</b>	_____
CB450K1-K7 Super Sport	68-74	<b>608-0152</b>	_____
CL450K1-K6 Scrambler	68-74	<b>608-0152</b>	_____
CX500	78-79	<b>608-052</b>	_____
CX500C Custom	79-82	<b>608-052</b>	_____
CX500D Deluxe	79-81	<b>608-052</b>	_____
GB500	89-90	<b>608-1138</b>	<b>609-5138</b>
GL500 Silverwing	81-82	<b>608-052</b>	_____
GL500I Silverwing Interstate	81-82	<b>608-052</b>	_____
XL500S	79-81	<b>608-059</b>	_____
CB550/K1	74-75	_____	<b>609-050</b>
CB550K	76-78	_____	<b>609-050</b>
CB550F Super Sport	75-77	_____	<b>609-050</b>
CB550SC Nighthawk	1983	<b>608-1072</b>	<b>609-5072</b>
CBR600F Hurricane	87-90	<b>608-1119</b>	<b>609-5119</b>
CBR600F2 Hurricane	91-94	<b>608-1160</b>	<b>609-5160</b>
CBR600F3 Hurricane	95-98	<b>608-1180</b>	<b>609-5180</b>
CBR600SE	1998	<b>608-1180</b>	<b>609-5180</b>
CBR600SJR Replica	1996	<b>608-1180</b>	<b>609-5180</b>
VT600C Shadow VLX	91-97	<b>608-1148</b>	<b>609-5148</b>
VT600C Shadow VLX	99-06	_____	<b>609-5176</b>
VT600CD Shadow VLX Deluxe	93-94	<b>608-1148</b>	<b>609-5148</b>
VT600CD Shadow VLX	95-06	_____	<b>609-5176</b>
VT600CD2 Shadow VLX	99-00	_____	<b>609-5176</b>
XL600R	83-87	<b>608-1081</b>	<b>609-5081</b>

### Honda Street

Model	Year	Complete	Top End
CB650SC Nighthawk	83-85	<b>608-1072</b>	<b>609-5072</b>
CX650C Custom	1983	<b>608-094</b>	<b>609-094</b>
GL650 Silverwing	1983	<b>608-094</b>	<b>609-094</b>
NT650 Hawk GT	88-90	_____	<b>609-5123</b>
NX650	88-89	_____	<b>609-5122</b>
XR650L Dual Sport	93-12	<b>VG-1152-M</b>	<b>609-5122</b>
CB700SC Nighthawk	84-86	<b>608-1073</b>	_____
VF700C Magna	84-85	_____	_____
VF700F Interceptor	84-85	<b>608-078</b>	<b>609-078</b>
VF700S Sabre	84-85	_____	_____
VFR700F/F2 Interceptor	86-87	_____	<b>609-5105</b>
VT700C Shadow	83-85	<b>608-093</b>	_____
CB750 Nighthawk 750	91-03	<b>608-1165</b>	<b>609-5165</b>
CB750A Automatic	76-78	<b>608-048</b>	<b>609-045</b>
CB750C Custom	80-82	<b>608-056</b>	<b>609-055</b>
CB750F Super Sport	75-78	<b>608-048</b>	<b>609-045</b>
CB750F Super Sport	79-82	<b>608-056</b>	<b>609-055</b>
CB750K	70-73	<b>608-0156</b>	<b>609-017</b>
CB750K4/K5	74-75	<b>608-048</b>	<b>609-045</b>
CB750/K	76-78	<b>608-048</b>	<b>609-045</b>
CB750K	79-82	<b>608-056</b>	<b>609-055</b>
CB750L LTD	1979	<b>608-056</b>	<b>609-055</b>
CB750SC Nighthawk	82-83	<b>608-056</b>	<b>609-055</b>
VF750C Magna	94-02	_____	<b>609-5170</b>
VF750C2 Magna	97-99	_____	<b>609-5170</b>
VF750CD Magna Deluxe	95-96	_____	<b>609-5170</b>
VF750F Interceptor	83-84	<b>608-078</b>	<b>609-078</b>
VF750S V45 Sabre	82-83	_____	_____
VFR750F	90-97	<b>608-1149</b>	<b>609-5149</b>
VT750C Shadow	1983	<b>608-093</b>	_____
PC800 Pacific Coast	89-90	_____	<b>609-5177</b>
PC800 Pacific Coast	94-98	_____	<b>609-5177</b>
CB900C Custom	80-82	<b>608-057</b>	_____
CB900F Super Sport	81-82	<b>608-057</b>	_____
CBR900RR	93-95	<b>608-1171</b>	<b>609-5171</b>
CBR900RR	96-98	<b>608-1186</b>	<b>609-5186</b>
CB1000	94-95	_____	<b>609-5173</b>
CBR1000F Hurricane	87-88	<b>608-1141</b>	<b>609-5141</b>
CB1000R	09-11	<b>608-1073</b>	<b>609-5173</b>
CB1000RA	09-10	<b>608-1073</b>	<b>609-5173</b>
CB1000R	09-11	<b>608-1073</b>	<b>609-5173</b>
CB1000RB	09-10	<b>608-1073</b>	<b>609-5173</b>
CBR1000F Hurricane	90-91	<b>608-1142</b>	_____
CBR1000F Hurricane	93-96	<b>608-1172</b>	<b>609-5172</b>
GL1000K Goldwing	75-79	_____	<b>609-046</b>
GL1000L Goldwing LTD	1975	_____	<b>609-046</b>
VF1000F Interceptor	1984	_____	<b>609-5075</b>
CB1100F Super Sport	1983	<b>608-097</b>	<b>609-097</b>
CBR1100XX Blackbird	97-03	_____	_____
GL1100 Goldwing	80-83	<b>608-067</b>	_____
GL1100A Goldwing Aspencade	82-83	<b>608-067</b>	_____
GL1100I Goldwing Interstate	80-83	<b>608-067</b>	_____
VF1100C V65 Magna	83-86	<b>608-1077</b>	<b>609-5077</b>
VF1100S V65 Sabre	84-85	<b>608-1077</b>	<b>609-5077</b>
VT1100C Shadow 1100	85-90	<b>608-1091</b>	_____
GL1200 Goldwing	1984	_____	<b>609-5106</b>
GL1200A Goldwing Aspencade	1984	_____	<b>609-5106</b>
GL1200I Goldwing Interstate	85-87	<b>608-1107</b>	<b>609-5106</b>
GL1200I Goldwing Interstate	1984	_____	<b>609-5106</b>
GL1200I Goldwing Interstate	85-87	<b>608-1107</b>	<b>609-5106</b>
GL1200L Goldwing LTD	1985	<b>608-1107</b>	<b>609-5106</b>
GL1500 Goldwing	88-90	<b>608-1150</b>	<b>609-5150</b>
GL1500A Goldwing Aspencade	91-99	<b>608-1150</b>	<b>609-5150</b>
GL1500C Valkyrie	97-00	<b>608-1150</b>	<b>609-5150</b>
GL1500C Valkyrie	02-03	<b>608-1150</b>	<b>609-5150</b>
GL1500CD Valkyrie	01-03	<b>608-1150</b>	<b>609-5150</b>
GL1500CF Valkyrie Interstate	99-01	<b>608-1150</b>	<b>609-5150</b>
GL1500CT Valkyrie Tourer	97-00	<b>608-1150</b>	<b>609-5150</b>
GL1500I Goldwing Interstate	91-96	<b>608-1150</b>	<b>609-5150</b>
GL1500SE Goldwing SE	92-00	<b>608-1150</b>	<b>609-5150</b>

## Honda ATV

Model	Year	Complete	Top End
TRX70 Fourtrax 70	86-87	<b>608-1060</b>	————
ATC90/K1/K2/K3	70-75	<b>608-045</b>	————
ATC90	76-78	<b>608-045</b>	————
TRX90 Fourtrax 90	93-98	<b>608-1166</b>	————
TRX90 Fourtrax 90	99-01	<b>VG-1195-M</b>	<b>609-5195</b>
TRX90 Sportrax 90	02-13	<b>VG-1195-M</b>	<b>609-5195</b>
ATC110	79-83	<b>608-017</b>	<b>609-0570</b>
ATC110	84-85	<b>608-080</b>	<b>609-0570</b>
ATC125M	1984	<b>608-081</b>	————
ATC125M	86-87	<b>608-1094</b>	————
TRX125 Fourtrax 125	85-86	<b>608-086</b>	————
TRX125 Fourtrax 125	87-88	<b>608-1094</b>	————
ATC185S	81-83	<b>608-063</b>	————
ATC200	81-83	<b>608-063</b>	————
ATC200E Big Red	82-83	<b>608-068</b>	<b>609-5015</b>
ATC200ES Big Red	1984	<b>608-079</b>	<b>609-5015</b>
ATC200M	84-85	<b>608-068</b>	<b>609-5015</b>
ATC200S	84-86	<b>608-065</b>	<b>609-5015</b>
ATC200X	83-85	<b>608-065</b>	<b>609-5015</b>
ATC200X	86-87	————	<b>609-5085</b>
TRX200	1984	<b>608-079</b>	<b>609-5015</b>
TRX200 Fourtrax 200	90-91	————	<b>609-5085</b>
TRX200D Fourtrax 200 Type II	91-97	————	<b>609-5085</b>
TRX200SX Fourtrax 200 SX	86-88	————	<b>609-5085</b>
ATC250ES Big Red	1985	<b>608-088</b>	————
ATC250ES Big Red	86-87	<b>608-090</b>	————
ATC250R	81-84	<b>608-064</b>	<b>609-064</b>
ATC250R	85-86	<b>608-1194</b>	<b>609-5194</b>
ATC250SX	1985	<b>608-088</b>	————
ATC250SX	86-87	<b>608-090</b>	————
FL250 Odyssey	78-84	<b>608-082</b>	————
TRX250 Fourtrax 250	85-87	<b>608-090</b>	————
TRX250 Recon	97-01	<b>608-1184</b>	<b>609-5184</b>
TRX250EX Sportrax 250EX	01-02	<b>608-1203</b>	<b>609-5203</b>
TRX250EX Sportrax 250EX	03-08	<b>608-1204</b>	<b>609-5204</b>
TRX250R Fourtrax 250R	86-89	<b>608-1096</b>	<b>609-5096</b>
TRX250TE Fourtrax Recon ES	02-12	<b>608-1200</b>	<b>609-5200</b>
TRX250TM Fourtrax Recon	02-12	<b>608-1200</b>	<b>609-5200</b>
TRX250X Fourtrax 250X	87-88	<b>608-1095</b>	<b>609-5095</b>
TRX250X Fourtrax 250X	91-92	<b>608-1095</b>	<b>609-5095</b>
TRX250X Fourtrax 250X	09-12	<b>608-1204</b>	<b>609-5204</b>
TRX300 Fourtrax 300	88-98	<b>608-1125</b>	<b>609-5125</b>
TRX300 Fourtrax 300	99-00	————	<b>609-5125</b>
TRX300EX Fourtrax 300EX	93-00	<b>608-1169</b>	<b>609-5095</b>
TRX300EX Sportrax 300EX	01-08	<b>608-1169</b>	<b>609-5095</b>
TRX300X Fourtrax 300X	2009	<b>608-1169</b>	<b>609-5095</b>
TRX300FW Fourtrax 300 4x4	1988	<b>608-1125</b>	<b>609-5125</b>
TRX300FW Fourtrax 300 4x4	90-98	<b>608-1125</b>	<b>609-5125</b>
TRX300FW Fourtrax 300 4x4	99-00	————	<b>609-5125</b>
ATC350X	85-86	<b>608-1061</b>	<b>609-5061</b>
FL350R Odyssey	1985	————	————
TRX350 Fourtrax 4x4	86-87	<b>608-1062</b>	<b>609-5061</b>
TRX350D Fourtrax Foreman 4x4	87-89	<b>608-1062</b>	<b>609-5061</b>
FL400R Pilot	89-90	<b>608-1137</b>	————
TRX400EX Fourtrax 400EX	99-00	<b>608-1192</b>	<b>609-5192</b>
TRX400EX Sportrax 400EX	01-04	<b>608-1192</b>	<b>609-5192</b>
TRX400EX Sportrax 400EX	2005	————	————
TRX400FM Fourtrax Foreman	2002	<b>608-1188</b>	<b>609-5188</b>
TRX400FW Fourtrax Foreman	95-01	<b>608-1188</b>	<b>609-5188</b>
TRX400FW Fourtrax Foreman	2003	<b>608-1188</b>	<b>609-5188</b>
TRX500FA Fourtrax Rubicon	01-12	<b>608-1209</b>	<b>609-5209</b>
TRX500FGA Fourtrax Rubicon	04-08	<b>608-1209</b>	<b>609-5209</b>

## Honda Dual Sport & Offroad

CRF50F	04-12	<b>VG-1216-M</b>	<b>VG-5216-M</b>
XR50R	00-03	————	<b>609-5154</b>
Z50R	92-00	————	<b>609-5154</b>
CT70	91-94	<b>608-1155</b>	<b>609-5155</b>
XR70R	97-03	<b>608-1155</b>	<b>609-5155</b>
XR75/K1/K2	73-75	<b>608-050</b>	————

## Honda Dual Sport & Offroad

Model	Year	Complete	Top End
XR75	1976	<b>608-050</b>	————
CRF50F	04-12	<b>VG-1216-M</b>	<b>VG-5216-M</b>
XR50R	00-03	————	<b>609-5154</b>
Z50R	92-00	————	<b>609-5154</b>
CT70	91-94	<b>608-1155</b>	<b>609-5155</b>
XR70R	97-03	<b>608-1155</b>	<b>609-5155</b>
XR75/K1/K2	73-75	<b>608-050</b>	————
XR75	1976	<b>608-050</b>	————
XR75	77-78	<b>608-083</b>	<b>609-083</b>
CR80R	1984	————	<b>609-099</b>
CR80R	1986	————	<b>609-5064</b>
CR80R	90-91	<b>608-1131</b>	<b>609-5131</b>
CR80R	92-02	<b>608-1156</b>	<b>609-5156</b>
CRF80F	04-12	<b>VG-1218-M</b>	<b>VG-5218-M</b>
XL80S	80-85	<b>608-083</b>	<b>609-083</b>
XR80	79-84	<b>608-083</b>	<b>609-083</b>
XR80R	85-88	<b>608-083</b>	<b>609-083</b>
XR80R	90-91	<b>608-083</b>	<b>609-083</b>
XR80R	92-02	<b>608-1167</b>	<b>609-5167</b>
CR85R	03-07	<b>608-1202</b>	<b>609-5202</b>
CR85RB	03-07	<b>608-1202</b>	<b>609-5202</b>
CRF100F	04-12	<b>VG-1219-M</b>	<b>VG-5219-M</b>
XL100S	79-85	<b>608-084</b>	————
XR100	81-84	<b>608-084</b>	————
XR100R	85-91	<b>608-084</b>	————
XR100R	92-03	<b>608-1157</b>	<b>609-5157</b>
CR125R	1983	<b>608-076</b>	<b>609-076</b>
CR125R	87-89	<b>608-1113</b>	<b>609-5113</b>
CR125R	90-98	<b>608-1132</b>	————
CR125R	1999	————	<b>609-5190</b>
CR125R	00-02	<b>608-1196</b>	<b>609-5196</b>
CR125R	2003	————	————
CR125R	2004	————	————
CR125R	05-07	————	————
TLR200 Reflex	86-87	<b>608-070</b>	————
XL200R	83-84	<b>608-070</b>	————
XR200 dual rear shock model	80-84	<b>608-070</b>	————
XR200R	81-83	<b>608-070</b>	————
XR200R	1985	<b>608-1083</b>	————
XR200R	86-88	<b>608-070</b>	————
XR200R	90-91	<b>608-1146</b>	————
XR200R	94-02	<b>608-1175</b>	<b>609-5175</b>
CRF230F	03-05	<b>608-1205</b>	<b>609-5205</b>
CR250R	1986	————	<b>609-5066</b>
CR250R	1987	<b>608-1098</b>	<b>609-5098</b>
CR250R	1988	————	<b>609-5133</b>
CR250R	89-91	<b>608-1134</b>	<b>609-5134</b>
CR250R	92-99	<b>608-1158</b>	<b>609-5158</b>
CR250R	00-01	<b>608-1198</b>	<b>609-5198</b>
CR250R	02-04	<b>608-1199</b>	<b>609-5199</b>
CR250R	05-07	<b>VG-1220-M</b>	<b>VG-5220-M</b>
CRF250R	04-07	<b>VG-1224-M</b>	<b>VG-5224-M</b>
CRF250R	08-09	<b>VG-1228-M</b>	<b>VG-5228-M</b>
CRF250X	04-12	<b>VG-1224-M</b>	<b>VG-5224-M</b>
XL250R	85-87	<b>608-1079</b>	<b>609-5079</b>
XR250L	91-96	<b>608-1079</b>	<b>609-5079</b>
XR250R	85-95	<b>608-1079</b>	<b>609-5079</b>
XR250R	96-99	<b>608-1182</b>	<b>609-5182</b>
XR250R	00-04	<b>608-1197</b>	<b>609-5197</b>
XR400R	96-03	<b>608-1183</b>	<b>609-5183</b>
CRF450R	02-07	<b>VG-1201-M</b>	<b>VG-5201-M</b>
CRF450R	09-12	<b>VG-1234-M</b>	<b>VG-5234-M</b>
CRF450X	05-12	<b>VG-1225-M</b>	<b>VG-5225-M</b>
CR500R	87-88	<b>608-1099</b>	————
CR500R	89-01	<b>608-1135</b>	<b>609-5135</b>
XR500	79-80	<b>608-059</b>	————
XL500S Dual Sport	79-81	<b>608-059</b>	————
XR500R	81-82	<b>608-059</b>	————
XR500R	83-84	<b>608-1084</b>	<b>609-5084</b>
XL600R Dual Sport	83-87	<b>608-1081</b>	<b>609-5081</b>



# Gasket Sets

## Honda Dual Sport & Offroad

Model	Year	Complete	Top End
XR600R	85-87	608-1081	609-5081
XR600R	88-00	608-1120	609-5120
XR650L Dual Sport	93-12	VG-1226-M	609-5122

## Kawasaki Street

AR50A1	1982	608-412	_____
AR80A1	1982	608-413	_____
KZ200A1/A2	78-79	608-624	_____
KL250D2-D22 KLR250	85-05	608-4017	609-8017
S1A/B/C-250 (2 stroke triple)	73-75	608-650	_____
KH250A5 (2 stroke triple)	1976	608-650	_____
S2-350/A (2 stroke triple)	72-73	608-655	_____
S3/S3A-400 (2 stroke triple)	74-75	608-656	_____
KH400A3/A4/A5 (2 stroke triple)	76-78	608-656	_____
KZ400B1/B2	78-79	608-0497	_____
KZ400C1	1978	608-0497	_____
KZ400H1 LTD	1978	608-0497	_____
KZ440A1/A2/A3/A4 LTD	80-83	608-0457	_____
KZ440B1/B2	80-81	608-0457	_____
KZ440D1/D2/D3/D4/D5 LTD Belt	80-83	608-0457	_____
EN500A1-A7 Vulcan 500	90-96	608-4018	_____
EN500C1-C10 Vulcan 500 LTD	96-05	608-4018	_____
EN500C6F Vulcan 500 LTD	2006	608-4018	_____
EX500A1-A7	87-93	608-4018	_____
EX500D1/D2/D3 Ninja 500	94-96	608-4018	_____
EX500D4-D12 Ninja 500R	97-05	608-4018	_____
H1/A/B/C-500	69-72	608-0421	_____
H1D/E/F-500 (2 stroke triple)	73-75	608-0421	_____
KH500A8 (2 stroke triple)	1976	608-0421	_____
KZ550C4 LTD	1983	608-0464	609-0864
KZ550D1 GPz	1981	608-0455	609-0855
KZ550F2 LTD Shaft	1984	_____	609-643
KZ550H1/H2 GPz	82-83	608-640	_____
ZR550B1/B2/B3 Zephyr	90-92	608-4045	609-8045
ZX550A1/A2/A3 GPz	84-86	_____	609-643
ZX600A1/A2/A3 Ninja 600R	85-87	608-4011	609-8011
ZX600C1-C10 Ninja 600R	88-97	608-4011	609-8011
ZX600E1-E10 Ninja ZX-6	93-02	608-4075	609-8075
ZX600E11/E12 ZZR600	03-04	608-4075	609-8075
KL650A1-A19 KLR650	87-05	_____	609-8021
KL650B2/B3 Tengai KLR650	90-91	_____	609-8021
KL650E8F-ECF KLR650	08-12	VG-4108-M	VG-8108-M
KZ650B1/B2/B2A	77-78	608-0481	609-0881
KZ650B3	1979	608-0482	609-0882
KZ650C1/C2 Custom	77-78	608-0481	609-0881
KZ650C3 Custom	1979	608-0482	609-0882
KZ650D1/D1A SR	1978	608-0481	609-0881
KZ650D2 SR	1979	608-0482	609-0882
KZ650E1 LTD	1980	608-0482	609-0882
KZ650F1	1980	608-0482	609-0882
H2/A-750 (2 stroke triple)	72-73	608-665	_____
H2B/H2C-750 (2 stroke triple)	74-75	608-665	_____
KZ750E1/E2/E3	80-82	608-0448	_____
KZ750F1 LTD Shaft	1983	608-631	609-631
KZ750H1/H2/H3 LTD	80-82	608-0448	_____
KZ750H4 LTD	1983	608-631	609-631
KZ750L3	1983	608-631	609-631
KZ750N1/N2 Spectre	82-83	608-631	609-631
ZX750A1/A2/A3 GPz	83-85	608-631	609-631
ZX750F1/F2/F3/F4 Ninja 750R	87-90	608-4031	609-8031
ZX750H1/H2 Ninja ZX-7	89-90	608-4046	609-8046
Z1A/B-900	74-75	608-618	609-0824
KZ900A4/A5	76-77	608-618	609-0824
KZ900B1 LTD	1976	608-618	609-0824
ZL900A1/A2 Eliminator	85-86	_____	_____
ZX900A1/A2/A3 Ninja 900R	84-86	608-4008	_____
KZ1000A1/A2/A2A	77-78	608-0436	609-0836
KZ1000A3/A3A/A4 MKII	79-80	608-619	609-611
KZ1000B1/B2 LTD	77-78	608-0436	609-0836
KZ1000B3/B4 LTD	79-80	608-619	609-611

## Kawasaki Street

Model	Year	Complete	Top End
KZ1000C1/C1A Police	1978	608-0436	609-0836
KZ1000C2/C3/C4 Police	79-81	608-619	609-611
KZ1000D1 Z1R	1978	608-0436	609-0836
KZ1000D3 Z1R	1980	608-619	609-611
KZ1000E1/E2 Shaft ST	79-80	_____	609-611
KZ1000G1 LTD Classic	1980	608-619	609-611
KZ1000J1/J2/J3	81-83	608-620	609-0839
KZ1000K1/K2 LTD	81-82	608-620	609-0839
KZ1000M1/M2 CSR	81-82	608-620	609-0839
KZ1000P1-P24 Police	82-05	608-620	609-0839
KZ1000R1/R2 Replica	82-83	608-620	609-0839
ZG1000A1-A13 Concours	86-98	608-4009	_____
ZG1000A14-A20 Concours	99-05	608-4076	609-8076
ZG1000A6F Concours	2006	608-4076	609-8076
ZL1000A1 Eliminator	1987	_____	_____
ZX1000A1/A2 Ninja 1000R	86-87	608-4009	_____
ZX1000B1/B2/B3 Ninja ZX-10	88-90	608-4032	609-8032
KZ1100A1/A2/A3 Shaft	81-83	608-621	609-0847
KZ1100B1/B2 GPz	81-82	608-621	609-0847
KZ1100D1/D2 Spectre	82-83	608-621	609-0847
KZ1100L1 LTD Shaft	1983	608-621	609-0847
ZN1100B1/B2 LTD Shaft	84-85	608-642	609-0847
ZX1100A1/A2 GPz	83-84	608-642	609-0847
ZX1100C1/C2/C3 Ninja ZX-11	90-93	608-4047	609-8047
ZX1100D1-D9 Ninja ZX-11	93-01	608-4047	609-8047
ZX1100E1/E2/E3 GPz1100	95-97	608-4047	609-8047
ZX1100F1 GPz1100 (ABS)	1996	608-4047	609-8047
ZG1200B1-B17 Voyager XII	87-03	608-4048	609-8048
KZ1300A1/A2/A3/A4	79-82	608-4010	609-8010
KZ1300B2 Touring	1980	608-4010	609-8010

## Kawasaki ATV

KSF80A1/A2/A3 KFX80	03-06	608-3106	VG-7106
KLT110A1/A2/A3	84-86	608-636	_____
KLT160A1	1985	608-638	_____
KLF185A1/A2/A3/A4 Bayou	85-88	608-639	_____
KLT185A1/A2	86-87	608-639	_____
KLT200A1/A2/A3/A4/A4A	81-83	608-624	_____
KLT200B1	1983	608-625	609-625
KLT200C1/C2	83-84	608-625	609-625
KLF220A1-A15 Bayou 220	88-02	608-4028	_____
KSF250A1-A17 Mojave	87-03	608-4022	_____
KSF250A18 KFX250 Mojave	2004	608-4022	_____
KXF250A1/A2 Tecate 4	87-88	608-4025	_____
KXT250B1/B2 Tecate 3	86-87	608-4002	_____
KEF300A1-A6 Lakota 300	95-00	608-4029	609-8029
KEF300B1/B2/B3 Lakota Sport	01-03	608-4029	609-8029
KLF300B1-B17 Bayou 300	88-04	608-4029	609-8029
KLF300C1-C16 Bayou 4x4	89-04	608-4030	609-8029
KVF300A1-A4 Prairie 300 4x4	99-02	VG-4074-M	VG-8074-M
KVF300 B1-B4 Prairie 300	99-02	VG-4074-M	VG-8074-M
KVF360A1/A2/A3 Prairie 360 4x4	03-05	VG-4083-M	VG-8083-M
KVF360B1-B9F Prairie 360	03-09	VG-4083-M	VG-8083-M
KVF360A6F-ACF	06-12	VG-4083-M	VG-8083-M
KVF360C6F-CAF Hardwoods	06-10	VG-4083-M	VG-8083-M
KVF360CAF-CBF Realtree	10-11	VG-4083-M	VG-8083-M
KLF400B1-B7 Bayou 4x4	93-99	608-4056	_____
KSF400A1-A6F KFX400	03-06	VG-4085-M	VG-8085-M

## Kawasaki Dual Sport & Offroad

KX60A1/A2	83-84	_____	609-634
KX60B1-B19	85-03	608-4000	_____
KX65A1/A2/A3/A4/A5/A6	00-05	608-4078	609-8078
KX65A6F-AD	06-13	_____	609-8078
KX80G1/G2	86-87	_____	609-8004
KX80J2	1987	_____	609-8004
KX80L1/L2	88-89	608-4024	_____
KX80N1/N2 Big Wheel 80	88-89	608-4024	_____
KX80R1-R7	91-97	608-4034	609-8034



**Kawasaki Dual Sport & Offroad**

Model	Year	Complete	Top End
KX80T1-T4	91-94	608-4034	609-8034
KX80W1/W2/W3	98-00	608-4069	609-8069
KX85A1/A2/A3/A4/A5	01-05	608-4079	609-8079
KX85A6F-ACF	06-12	_____	609-8079
KX100B5/B6/B7	95-97	608-4055	609-8055
KX100C1/C2/C3	98-00	608-4070	609-8070
KX100D1/D2/D3/D4/D5	01-05	608-4070	609-8070
KX100D6F-DCF	06-12	_____	609-8070
KX125A/A3	74-76	608-645	_____
KX125F1/G1	88-89	608-4035	609-8035
KX125H1/H2	90-91	608-4036	_____
KX125K1	1994	608-4057	_____
KX125K2/K3/K4	95-97	608-4062	_____
KX125K5/L1	98-99	608-4065	609-8065
KDX200E1-E6	89-94	608-4040	609-8040
KDX200H1-H11	95-06	608-4064	609-8064
KDX200H6F	2006	608-4064	609-8064
KDX220A4-A12	97-05	608-4071	609-8071
KDX250B2/B3/B4	91-93	_____	609-630
KDX250D1/D2/D3	91-93	608-4059	_____
KL250D2-D22 KLR250	85-05	608-4017	609-8017
KX250B1	1982	_____	609-630
KX250D1/D2	85-86	608-4002	_____
KX250F1/G1	88-89	608-4042	609-8042
KX250H1/H2	90-91	608-4043	609-8043
KX250J1	1992	608-4051	609-8043
KX250J2	1993	_____	609-8054
KX250K1	1994	608-4058	609-8054
KX250K2/K3	95-96	608-4063	609-8063
KX250K4/K5	97-98	608-4066	609-8063
KX250L1/L2	99-00	608-4066	609-8063
KX250M1/M2	01-02	608-4077	609-8077
KX500A1/A2	83-84	608-641	_____
KX500B2/C1	86-87	608-4007	_____
KX500E1-E16	89-04	608-4026	609-8026
KL650A1-A19 KLR650	87-05	_____	609-8021
KL650B2/B3 Tengai KLR650	90-91	_____	609-8021
KLR650E8F-ECF KLR650	08-12	VG-4108-M	VG-8108-M

**Suzuki Street**

SP100D Dual Sport	1983	608-0396	_____
DR200SET/V/W/X/Y	96-00	_____	609-7117
DR250SL Dual Sport	1990	608-3072	_____
DR250SM/SN Dual Sport	91-92	608-3080	609-7080
DR250SEP/SER Dual Sport	93-94	608-3086	609-7086
DR250SES Dual Sport	1995	608-3107	609-7086
DR350SL Dual Sport	1990	608-3073	_____
DR350SM/SN/SP Dual Sport	91-93	608-3077	609-7077
DR350SER Dual Sport	1994	608-3111	609-7104
DR350SES/T/V/W/X Dual	95-99	608-3111	609-7104
GT380 J/K/L/M/A/B Sebring	72-77	_____	_____
GS400B/XB/C/XC	77-78	_____	_____
GS450ET/EX/EZ	80-82	_____	_____
GS450LT/LX	80-81	_____	_____
GS450ST/SX	80-81	_____	_____
GS450TX	1981	_____	_____
GS500EK/EL/EM/EN	89-92	608-3074	609-7074
GS500EP/ER/ES	93-95	608-3074	609-7074
T500R/J/K/L/M Titan	71-75	608-0329	_____
GT500A/B	76-77	608-0329	_____
GS550B/C/EC/N/EN/ET	77-80	608-0345	_____
GS550LN/LT/LX/LZ	79-82	608-0345	_____
GSF600ST/SV Bandit	96-97	608-3097	_____
GSF600SW/SX/SY Bandit	98-00	608-3128	609-7128
GSF600SK1/SK2/SK3 Bandit	01-03	608-3128	609-7128
G SX600FJ/FK/FL Katana	88-90	608-3044	_____
G SX600FM/FN/FP Katana	91-93	608-3097	_____
G SX600FR/FS Katana	94-95	608-3097	_____
G SX600FT/FV Katana	96-97	608-3097	_____
G SX600FW/FX/FY Katana	98-00	608-3128	609-7128

**Suzuki Street**

Model	Year	Complete	Top End
G SX600FK1/FK2/FK3 Katana	01-03	608-3128	609-7128
G SX600FK4-K6 Katana	04-06	608-3128	609-7128
G SX-R600V/W/X/Y	97-00	_____	_____
DR650SL/SM/SN/SP Dual	90-93	608-3082	_____
DR650SER/SES Dual Sport	94-95	608-3082	_____
LS650FG/FH Savage	86-87	608-3049	_____
LS650PG/PH/PJ Savage	86-88	608-3049	_____
LS650PS-PK4	95-04	608-3049	_____
GS750ET/EX	80-81	_____	609-0759
GS750EZ	1982	_____	_____
GS750ED/ESD	1983	608-3003	609-7003
GS750LT/LX	80-81	_____	609-0759
GS750TZ/TD	82-83	_____	_____
GS750SD Katana	1983	608-3002	609-7002
G SX750FK Katana	1989	608-3045	_____
G SX750FL/FM/FN/FP Katana	90-93	608-3060	609-7060
G SX750FR/FS/FT/FV Katana	94-97	608-3060	609-7060
G SX750FW/FX/FY Katana	98-00	608-3129	609-7129
G SX750FK1/FK2/FK3 Katana	01-03	608-3129	609-7129
G SX750FK4-K6 Katana	04-06	608-3129	609-7129
G SX-R750G	1986	608-3021	_____
G SX-R750J/K	88-89	608-3045	_____
G SX-R750L	1990	_____	609-7061
G SX-R750M/N	91-92	608-3083	_____
G SX-R750WP/WR/WS	93-95	608-3098	609-7098
G SX-R750TV/W/X	96-99	_____	_____
VS750GLPJ/K/L/M Intruder	88-91	_____	609-7064
GS850GN/GT/GX	79-81	608-440	_____
GS850GZ/GD	82-83	_____	_____
GS850GLT/GLX	80-81	608-440	_____
GS850GLZ/GLD	82-83	_____	_____
RF900RR/RS/RT/RV	94-97	608-3115	_____
RF900RZS	1995	608-3115	_____
GS1000C/EC/N/EN/ET	78-80	608-0352	_____
GS1000LN	1979	608-0352	_____
GS1000SN/ST	79-80	608-0352	_____
GS1100ET/EX	80-81	608-421	_____
GS1100EZ	1982	608-0380	_____
GS1100ED/ESD	1983	608-429	_____
GS1100GZ/GD	82-83	608-430	_____
GS1100GLZ/GLD	82-83	608-430	_____
GS1100GKZ/GK2/GKD/GKE	82-84	608-430	_____
GS1100LT	1980	608-421	_____
GS1100SD Katana	1983	608-429	_____
G SX1100FJ/FK/FL Katana	88-90	608-3062	609-7062
G SX1100FM/FN Katana	91-92	608-3076	609-7076
G SX1100GM/GN Shaft	91-92	608-3085	609-7085
G SX-R1100G/H	86-87	608-3024	609-7024
G SX-R1100J	1988	608-3046	609-7046
G SX-R1100K/L/M/N	89-92	608-3063	609-7063
G SX-R1100WP/WR/WS	93-95	608-3099	609-7099
G SX-R1100WT/WV/WWW	96-98	608-3099	609-7099
GS1150ES3/ESE/EF/ESF/EF2	83-85	608-3027	_____
GSF1200SV/SW/SX/SY Bandit	97-00	608-3124	609-7124
GSF1200SK1/SK2 Bandit	01-02	608-3124	609-7124
VS1400GLFH Intruder	1987	608-3065	_____
VS1400GLPH/GLPJ Intruder	87-88	608-3065	_____
VS1400GLPL/M/N/P/R/S	90-95	608-3065	_____
VS1400GLPT/V/W/X/Y	96-00	608-3065	_____
VS1400GLPK1/K2/K3 Intruder	01-03	608-3065	_____

**Suzuki ATV**

ALT50D/E	83-84	608-0392	609-0792
LT50E/F/G/H/J/K/L Quadrunner	84-90	608-0392	609-0792
LT-A50K2/K3/K4/K5	02-05	608-3131	609-7131
LT80H/J/K/L/M/N/P/R Quadrunner	87-94	608-3048	609-7048
LT80S/T/V/W/X/Y Quadrunner	95-00	608-3106	609-7106
LT80K1/K2/K3/K4 Quadrunner	01-04	608-3106	609-7106
ALT125D/E/F/G	83-86	608-423	_____
LT125D/E/F/G/H	83-87	608-423	_____

# Gasket Sets

## Suzuki ATV

Model	Year	Complete	Top End
LT160EK/EL/EM/EN	89-92	608-3092	609-7092
LT-F160M/N/P/R/S/T/V	91-97	608-3092	609-7092
LT-F160W/X/Y/K1 Quadrunner	98-01	608-3092	609-7092
LT-F160K3	2003	608-3092	609-7092
ALT185E/F	84-85	608-435	————
LT185E/F/G/H	84-87	608-435	————
LT-F230G/H	86-87	608-436	————
LT230EH/EJ/EK/EL	87-90	608-436	————
LT230EM/EN/EP	91-93	608-436	————
LT230GEF/GEG	85-86	608-436	————
LT230SF/SG/SH/SJ	85-88	608-3015	————
LT-4WDH/J/K/L Quadrunner	87-90	608-3025	609-7025
LT-4WDM/N P/R Quadrunner	91-94	608-3025	609-7025
LT-4WDS Quadrunner	1995	608-3110	609-7025
LT-4WDT/V/W Quadrunner	96-98	608-3108	609-7108
LT-F250J/K/L/M/N/P/R	88-94	608-3025	609-7025
LT-F250S/T/V/W/X/Y/K1	95-01	608-3108	609-7108
LT-F250F X-K2	99-02	608-3108	609-7108
LT-F250K2-K9/L0/L1/L2 Ozark	02-12	VG-3136-M	VG-7136-M
LT250EFF/EF	85-86	608-438	————
LT250RF/RG Quad Racer	85-86	608-439	609-7017
LT250RH/RJ/RK Quad Racer	87-89	608-3057	609-7057
LT250RL/RM/RN Quad Racer	90-92	608-3057	609-7057
LT-F4WDXM/N/P King Quad	91-93	608-3095	609-7095
LT-F4WDXR/S/T/V/W	94-98	608-3109	609-7109
LT-Z400K3-K9/L0/L1/L2 QuadSport	03-12	VG-4085-M	VG-8085-M
LT500RJ/RK/RL Quadracer	88-90	608-3066	609-7066
LT-F500F W-K2 Quadrunner	98-02	608-3127	609-7127
LT-F500F K3-K7Vinson 4WD	03-07	608-3127	609-7127

## Suzuki Dual Sport & Offroad

JR50C/N/T/X/Z/D/E/F/G/H/J	78-88	————	609-0792
JR50K/L/M/N/P/R/S/T/V/W/X/Y	89-00	————	609-0792
JR50 K1-K6	01-06	————	609-0792
RM80G/H/J	86-88	608-3038	————
RM80K	1989	608-3047	————
RM80L	1990	————	————
RM80M/N/P/R/S/T/V	91-97	608-3068	609-7068
RM80W/X/Y/K1	98-01	608-3068	609-7068
DR100D/E/F/G/H/J/K/L	83-90	608-0396	————
SP100D Dual Sport	1983	608-0396	————
RM125G	1986	608-3031	————
RM125K	1989	608-3052	————
RM125L	1990	608-3053	609-7053
RM125M	1991	————	609-7069
RM125N/P/R/S/T	92-96	608-3078	609-7078
RM125V	1997	————	609-7118
RM125W/X/Y	98-00	608-3125	————
RM125K1/K2/K3	01-03	608-3133	————
RM125 K4-K9	04-09	608-3134	609-7134
DR200SET/V/W/X/Y	96-00	VG-3117-M	609-7117
DR200SEK1-SEK9	01-09	VG-3117-M	609-7117
DR250SL Dual Sport	1990	608-3072	————
DR250SM/SN Dual Sport	91-92	608-3080	609-7080
DR250SEP/SER Dual Sport	93-94	608-3086	609-7086
DR250SES Dual Sport	1995	608-3107	609-7086
DR-Z250K1-K7	01-07	VG-3150-M	VG-7150-M
RM250E/F	84-85	608-3020	609-7020
RM250K	1989	608-3055	609-7055
RM250L	1990	608-3056	609-7055
RM250M	1991	608-3071	609-7071
RM250N/P	92-93	608-3081	609-7081
RM250R/S/T/V	94-95	608-3094	609-7094
RM250W	1998	608-3126	609-7126
RM250X/Y	99-00	608-3130	609-7130
RM250 K1-K9	01-09	608-3132	609-7132
RMX250P/R/S/T	93-96	608-3103	609-7103
RMX250V/W	97-98	608-3120	609-7103
RM-Z250K5/K6	05-06	VG-3149-M	VG-7149-M

## Suzuki Dual Sport & Offroad

Model	Year	Complete	Top End
RM-Z250K7/K8/K9	07-09	VG-3154-M	VG-7154-M
DR350SL Dual Sport	1990	608-3073	————
DR350SM/SN/SP Dual Sport	91-93	608-3077	609-7077
DR350SER Dual Sport	1994	————	609-7104
DR350SES/T/V/W/X Dual Sport	95-99	608-3111	609-7104
RM500D	1983	608-426	————
DR650SL/SM/SN/SP Dual	90-93	608-3082	————
DR650SER/SES Dual Sport	94-95	608-3082	————

## Yamaha Street

YSR50T/U/W/A/B/D	87-92	608-2057	————
TW200U/UC/W/WC/A/AC	88-90	————	609-6088
TW200B/BC/-H/HC Trailway	91-96	————	609-6088
TW200 J/JC-P/PC Trailway	97-02	————	609-6129
XT225D/DC-P/PC Serrow	92-02	608-2077	609-6076
RD350/A/B	73-75	608-0251	609-205
RZ350L/N/NC/NCII	84-85	608-255	————
XT350N/NC-B/BC Dual Sport	85-91	————	609-6062
XT350D/DC-M/MC Dual Sport	92-00	608-2113	609-6113
FZR400U/SUC/W/SWC/A/SAC	88-90	608-2091	————
RD400C/D/E/F	77-79	608-0261	————
SR500E/F/G/H	78-81	608-231	609-231
XT500C/D/E/F/G Dual Sport	76-81	608-231	609-231
XV500K Virago	1983	————	609-6023
XV535T/TC/U/UC Virago	87-88	608-2078	————
XV535E/EC-J/JC Virago	93-97	608-2078	————
XV535SF/SFC-SJ/SJC Virago	94-97	608-2078	————
XV535K/KC/L/LC/M/MC	98-00	————	————
XJ550H/J/K Maxim	81-83	608-253	609-253
XJ550RH/RJ/RK Seca	81-83	608-253	609-253
XT550J/K Dual Sport	82-83	608-240	————
XZ550RJ Vision	1982	608-2025	————
FJ600L/LC/N/NC	84-85	————	————
FZ600S/SC/T/TC/U/UC	86-88	————	————
FZR600W/WC/AC	89-90	608-2092	————
FZR600RA/RAC-RL/RLC	90-99	608-2092	————
SRX600S/SC	1986	608-254	609-254
XJ600SD/SDC-SK/SKC Seca II	92-98	————	609-6115
XT600L/LC Dual Sport	1984	608-254	609-254
XT600T/TC Dual Sport	1987	608-254	609-254
XT600EA/EAC/EB/EBC/ED/EDC	90-92	608-2080	609-6080
YX600S/SC/T/TC/U/UC Radian	86-88	608-2063	————
YX600W/WC/A/AC Radian	89-90	608-2063	————
XJ650G/H Maxim	80-81	608-2016	609-6016
XJ650LH Midnight Maxim	1981	608-2016	609-6016
XJ650LJ/LK Seca Turbo	82-83	608-2017	609-6017
XJ650RJ Seca	1982	608-2016	609-6016
XS650B/C/D/E/F	75-79	608-0282	————
XS650G/H Special II	80-81	608-0282	————
XS6502F	1979	608-0282	————
XS650SE/SF/SG/SH Special	78-81	608-0282	————
XS650SJ/SK Heritage Special	82-83	608-251	609-251
FZ700T/TC	1987	608-2064	609-6064
FZ750N/S/SC	85-86	608-2064	609-6064
FZ750U/UC	1988	608-2064	609-6064
FZR750RT/RU	87-88	608-2064	609-6064
XJ750J/K Maxim	82-83	608-2014	————
XJ750MK Midnight Maxim	1983	608-2014	————
XJ750RH/RJ/RK Seca	81-83	608-2014	————
XV750H/J/K Virago	81-83	608-249	609-249
XV750MK Midnight Virago	1983	608-249	609-249
XV750U/UC/M/WC Virago	88-89	608-2081	————
XV750A/AC/B/BC/D/DC Virago	90-92	608-2081	————
YZF750RF/RFC	1994	————	609-6122
YZF750RH/RHC/RJ/RJC/RK/RKC	96-98	————	609-6122
XS850G/H	80-81	608-2000	————
XS850LG/LH Midnight Special	80-81	608-2000	————
XS850SG/SH Special	80-81	608-2000	————
XV920J/K Virago	82-83	608-248	————
XV920MK Midnight Virago	1983	608-248	————
XV920RH/RJ Virago	81-82	608-248	————
FZR1000U/UC	1988	————	609-6082

## Yamaha Street

Model	Year	Complete	Top End
FZR1000W/WC/A/AC/B/BC	89-91	608-2094	_____
FZR1000D/DC/E/EC	92-93	608-2118	609-6118
FZR1000F/FC/G/GC	94-95	608-2118	609-6118
GTS1000AE/AEC/AF/AFC	93-94	608-2118	609-6118
XV1000L/LC/N/NC Virago	84-85	608-2050	_____
FJ1100L/LC/N/NC	84-85	608-2056	_____
XJ1100J Maxim	1982	608-0297	_____
XS1100E/F/G/H	78-81	608-250	609-250
XS1100LG/LH Midnight Special	80-81	608-250	609-250
XS1100SF/SG/SH Special	79-81	608-250	609-250
XV1100U/JC-F/FC Virago	88-94	608-2050	_____
XV1100G/GC/H/HC/J/JC Virago	95-97	608-2123	_____
XV1100K/KC/L/LC Virago	98-99	608-2123	_____
XV1100SH/SHC/SJ/SJC Virago	96-97	608-2123	_____
XV1100SK/SKC Virago	1998	608-2123	_____
FJ1200S/SC/T/TC	86-87	_____	_____

## Yamaha ATV

YFM80N/S/T/U Moto-4	85-88	608-2074	609-6074
YFM80D/E/F/G/H/J/K Badger	92-98	608-2074	609-6074
YFM80L/M/MC/N/NC Badger	99-01	608-2074	609-6074
YFM200N Moto-4	1985	608-238	_____
YFM200DXS/DXT Moto-4	86-87	608-2089	609-6089
YFM200DXU/DXW Moto-4	88-89	608-2089	609-6089
YFS200U-P Blaster	88-02	608-2095	609-6095
YFS200R/S/T/V	03-06	VG-2145	VG-6145
YFS200SEV	2006	VG-2145	VG-6145
YTM200EK/EL/ERN	83-85	608-238	_____
YFM225S/T/U Moto-4	86-88	_____	609-6076
YTM225DRN Tri-Moto	1985	608-239	_____
YTM225DRS Tri-Moto	1986	_____	609-6076
YTM225DXK/DXL/DXN Tri-Moto	83-85	608-239	_____
YTZ250N/S Tri-Z	85-86	608-2058	_____
YFM350ERT-ERA Moto-4	87-90	608-2060	609-6060
YFM350ERD Moto-4	1992	608-2060	609-6060
YFM350ERE/ERF/ERG Moto-4	93-95	608-2107	609-6107
YFM350FHL/FHLC Wolverine	1999	608-2139	609-6107
YFM350FWT/U/W/A/B Big Bear	87-91	608-2060	609-6060
YFM350FWD-FWJ Big Bear	92-97	608-2107	609-6107
YFM350FWBJ/FWBK Big Bear	97-98	608-2125	_____
YFM350FWBKC Big Bear	1998	608-2125	_____
YFM350FWBL/FWBLC Big Bear	1999	608-2139	609-6107
YFM350FXG-FXK Wolverine	95-98	608-2125	_____
YFM350UH/UJ/UK Big Bear	96-98	608-2107	609-6107
YFM350UL/ULC Big Bear	1999	608-2139	609-6107
YFM350XT/XU/XW/XA/XB Warrior	87-91	608-2060	609-6060
YFM350XD-XP/XPC Warrior	92-04	608-2107	609-6107
YFM350 S-V Raptor 350	04-06	VG-2147	VG-6147
YFM350R T-Y Raptor 350	05-09	VG-2147	VG-6147
YFP350U Terapop	1988	_____	609-6060
YFZ350T/U/W/A/B Banshee	87-91	608-2059	609-6059
YFZ350D-P Banshee	92-02	608-2141	609-6141
YFZ350R/S/T/V Banshee	03-09	VG-2148	VG-6148
YFZ350LER/LES Banshee	03-04	VG-2148	VG-6148
YFZ350RB Banshee	2003	VG-2148	VG-6148
YFM400FM/FMC Big Bear 4WD	2000	608-2139	609-6107
YFM400FP Big Bear 4WD Realtree	2002	608-2139	609-6107
YFM400FWR Big Bear	2003	608-2139	609-6107
YFM400FHM Big Bear	2000	608-2139	609-6107
YFM400FHP Big Bear 400	2002	608-2139	609-6107
YFM400FWR Big Bear	2003	608-2139	609-6107
YFM400FWM/MC Big Bear 4WD	2000	608-2139	609-6107
YFM400FWE/F/G/H/J/K Kodiak	93-98	608-2107	609-6107
YFM400FWM/MC Big Bear 4WD	2000	608-2139	609-6107
YFM400FWNN Big Bear 4WD	2001	608-2139	609-6107
YFM400FWNHN Big Bear	2001	608-2139	609-6107
Buckmaster 4WD			
YFM400NM/NMC/N Big Bear 2W	01-02	608-2139	609-6107
YFM400NR Big Bear 2WD	2003	608-2139	609-6107
YFM400NHN Big Bear 2WD	2001	608-2139	609-6107
YFM400FS/FT/FV Big Bear 4x4	04-06	608-2139	609-6107
YFM400F S-T Big Bera 4x4	10-12	608-2139	609-6107

## Yamaha Dual Sport & Offroad

Model	Year	Complete	Top End
PW50H/J/K Y-Zinger	81-83	608-2021	_____
PW50N Y-Zinger	85-86	608-2021	_____
PW50A-B Y-Zinger Mini	90-12	608-2021	_____
TT-R50E V-B	06-12	VG-2149	VG-6149
YZ60H/J/K	81-83	608-252	609-252
PW80G/H/J/K/L/M1/N1/P	95-02	608-2022	609-6022
YZ80	87-92	608-2070	609-6070
YZ80	93-01	608-2104	609-6104
YZ85 P-A	02-11	VG-2149	VG-6149
TT-R125 M/ML-S	00-04	VG-2163	VG-6163
TT-R125 S-W	04-07	VG-2163	VG-6163
TT-R125X/Y	08-09	VG-2171	VG-6171
TT-R125L M-V	00-06	VG-2163	VG-6163
TT-R125L X	2008	VG-2171	VG-6171
TT-R125LE S-W	04-07	VG-2163	VG-6163
TT-R125LE X-B	08-12	VG-2171	VG-6171
YZ125W	1989	608-2071	_____
YZ125B	1991	_____	609-6098
YZ125D1	1993	608-2102	609-6102
YZ125F1/G1/H1/J1	94-97	608-2119	609-6119
YZ125K1	1998	VG-2133	609-6133
YZ125L1/M1/N1/P/R/S1	99-04	608-2138	609-6133
YZ125 T-B1	05-12	VG-2161	VG-6161
TW200U/UC/H/HC Trailway	88-96	_____	609-6088
TW200 J/JC-B1 Trailway	97-12	_____	609-6129
TT225S/T	86-87	608-2077	609-6076
TT-R225L/LC/M/MC/N/NC	99-01	_____	609-6130
XT225D/DC-H/HC Serrow	92-96	608-2077	609-6076
XT225J/JC-W/WC Serrow	97-07	_____	609-6130
IT250H/J/K	81-83	608-246	_____
YZ250U/W	88-89	_____	609-6072
YZ250G1	1995	608-2124	609-6124
YZ250H1	1996	608-2126	609-6124
YZ250J1	1997	608-2131	_____
YZ250K1	1998	608-2134	609-6134
XT350N/NC-A/AC Dual Sport	85-91	_____	609-6062
XT350D/DC-M/MC Dual Sport	92-00	608-2113	609-6113
IT490K	1983	608-247	_____
YZ490J/K	82-83	608-247	_____
TT500C/D/E/F/G/H	76-81	608-231	609-231
WR500ZD	1992	608-2114	609-6114
XT500C/D/E/F/G/H Dual Sport	76-81	608-231	609-231
XT550J/K Dual Sport	82-83	608-240	_____
XT600L/LC Dual Sport	1984	608-254	_____
XT600T/TC Dual Sport	1987	608-254	_____
XT600EA/EAC/EB/EBC/ED/EDC	90-92	608-2080	609-6080



# Gasket Sets

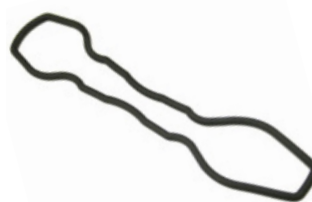
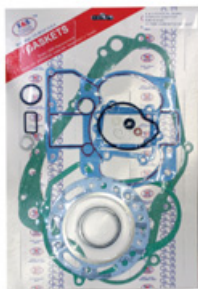

650-001



650-005

## K&S Engine Gasket Sets

Quality gasket sets from K&S International available in complete and top end sets.

### Suzuki ATV

Model	Year	Complete	Top End
LT250RJ/RK/RL Quadracer	88-92	<b>608-970</b>	<b>609-970</b>
LT500RH/RJ/RK/RL/RM Quadracer	88-90	<b>608-971</b>	————

### KTM

50 Mini Adventure	02-03	<b>608-933</b>	————
50 SXR Adventure	97-99	<b>608-931</b>	————
50 SX/SXR Pro	97-01	<b>608-932</b>	————
50 SXPro Jr.	01-03	<b>608-934</b>	————
60 SX	98-00	<b>608-935</b>	————
125 EXC/MXC/SX	98-03	<b>608-936</b>	————
200 EXC/MXC/SX	98-03	<b>608-937</b>	————

### Yamaha ATV & Offroad

YFS200 U-V Blaster	88-07	<b>608-928</b>	————
YZ250	99-04	<b>608-926</b>	<b>609-926</b>
YFZ350 Banshee	87-06	<b>608-929</b>	————
YFM660RN/RNC/RP/RPB Raptor	01-02	<b>608-927</b>	————
YFM660R N/RRC/RS/RT Raptor	01-05	<b>608-927</b>	————
YFM660RLER/RLES	03-04	<b>608-927</b>	————
Raptor 660R Limited Edition Blk			
YFM660RSET Raptor SE	2005	<b>608-927</b>	————

## Cylinder Head O-Rings

Kawasaki models. Sold each. *Made in Japan.*

### Kawasaki

OEM Ref. 92055-062 Order No. **650-001**

Model	Year
Z1/A/B-900	73-75
KZ900A4/A5	76-77
KZ900B1 LTD	1976
KZ1000A1/A2	77-78
KZ1000A3/A3A/A4 MKII	79-80
KZ1000B1/B2/B3/B4 LTD	77-80
KZ1000C1/C1A/C2/C3/C4 Police	78-81
KZ1000D1 Z1R	1978
KZ1000D3 Z1R	1980
KZ1000E1/E2 Shaft ST	79-80
KZ1000G1 LTD Classic	1980

OEM Ref. 11009-1208 Order No. **650-005**

Model	Year
KZ1000J1/J2/J3	81-83
KZ1000K1/K2 LTD	81-82
KZ1000M1/M2 CSR	81-82
KZ1000P1-P21 Police	82-02
KZ1000P24 Police	2005
KZ1000R1/R2 Replica	82-83
KZ1100A1/A2/A3 Shaft	81-83
KZ1100B1/B2 GPz	81-82
KZ1100D1/D2 Spectre	82-83
KZ1100L1 LTD	1983
ZN1100B1/B2 LTD Shaft	84-85
ZX1100A1/A2 GPz	83-84





644-1022



645-1028

## Vesrah Base & Head Gaskets

Replacement base and head gaskets for applications listed.  
Sold each. *Made in Japan.*

### Honda Street

Model	Year	Base Gskt	Head Gskt
CB600F (599)	2006	_____	<b>644-1096</b>
CBR600F3 Hurricane	95-98	_____	<b>644-1096</b>
CBR600SE Hurricane	1998	_____	<b>644-1096</b>
CBR600SJ Replica	1996	_____	<b>644-1096</b>
NT650 Hawk GT	88-91	_____	<b>644-1073</b>
NX650	88-89	_____	<b>644-1081</b>
VFR700F Interceptor	1986	_____	<b>644-1047</b>
VFR700F2 Interceptor	86-87	_____	<b>644-1047</b>
CB750 Nighthawk	91-03	_____	<b>644-1099</b>
CB750A Automatic	76-78	<b>645-1028</b>	<b>644-1022</b>
CB750C Custom	80-82	_____	<b>644-1023</b>
CB750F Super Sport	75-76	<b>645-1028</b>	_____
CB750F Super Sport	79-82	_____	<b>644-1023</b>
CB750/K1/K2/K3/K4/K5	69-75	<b>645-1028</b>	_____
CB750K	76-78	<b>645-1028</b>	<b>644-1022</b>
CB750K	79-82	_____	<b>644-1023</b>
CB750L LTD	1979	_____	<b>644-1023</b>
CB750SC Nighthawk	82-83	_____	<b>644-1023</b>
VF750C Magna	94-03	_____	<b>644-1078</b>
VF750C2 Magna	97-00	_____	<b>644-1078</b>
VF750CD Magna Deluxe	95-96	_____	<b>644-1078</b>
VFR750F Interceptor	1986	_____	<b>644-1047</b>
VFR750F	90-97	_____	<b>644-1078</b>
VFR1000F Interceptor	1984	_____	<b>644-1063</b>
VFR1000R	1985	_____	<b>644-1063</b>
VF1100C V65 Magna	83-86	_____	<b>644-1065</b>
VF1100S V65 Sabre	84-85	_____	<b>644-1065</b>

### Honda ATV

ATC185	1980	_____	<b>644-1028</b>
ATC185S	81-83	_____	<b>644-1028</b>
ATC200	81-83	_____	<b>644-1028</b>
ATC200E	82-83	_____	<b>644-1028</b>
ATC200ES	1984	_____	<b>644-1028</b>
ATC200M	84-85	_____	<b>644-1028</b>
ATC200S	84-86	_____	<b>644-1028</b>
ATC200X	83-85	_____	<b>644-1028</b>
ATC200X	86-87	_____	<b>644-1035</b>
TRX200 Fourtrax	1984	_____	<b>644-1028</b>
TRX200 Fourtrax 200	90-91	<b>645-1058</b>	<b>644-1035</b>
TRX200D Fourtrax Type II	91-97	<b>645-1058</b>	<b>644-1035</b>
TRX200SX Fourtrax	86-88	<b>645-1058</b>	<b>644-1035</b>
ATC250ES	85-86	<b>645-1026</b>	<b>644-1020</b>
ATC250ES	1987	_____	<b>644-1020</b>
ATC250R	85-86	<b>645-1025</b>	<b>644-1008</b>
ATC250SX	85-86	<b>645-1026</b>	<b>644-1020</b>
TRX250 Fourtrax 250	85-87	<b>645-1026</b>	<b>644-1020</b>
TRX250R Fourtrax 250R	86-89	<b>645-1025</b>	<b>644-1044</b>
TRX250X	87-88	_____	<b>644-1042</b>
TRX300 Fourtrax 300	88-00	<b>645-1026</b>	<b>644-1020</b>
TRX300EX Fourtrax 300EX	93-00	_____	<b>644-1042</b>
TRX300EX Sportrax 300EX	01-08	_____	<b>644-1042</b>
TRX300FW Fourtrax 300 4x4	1988	<b>645-1026</b>	<b>644-1020</b>
TRX300FW Fourtrax 300 4x4	90-00	<b>645-1026</b>	<b>644-1020</b>
ATC350X	85-86	_____	<b>644-1027</b>
FL350R Odyssey	1985	_____	<b>644-1045</b>

### Honda ATV

Model	Year	Base Gskt	Head Gskt
TRX350 Fourtrax 4x4	86-87	_____	<b>644-1027</b>
TRX350D Fourtrax Foreman 4x4	87-89	_____	<b>644-1027</b>
TRX400EX Fourtrax 400EX	99-00	<b>645-1061</b>	_____
TRX400EX Sportrax 400EX	01-12	<b>645-1061</b>	_____

### Honda Dual Sport & Offroad

CRF50	04-09	_____	<b>644-1084</b>
XR50R	00-03	_____	<b>644-1084</b>
Z50R	92-00	_____	<b>644-1084</b>
CRF70	04-09	_____	<b>644-1087</b>
XR70R	97-03	_____	<b>644-1087</b>
CT70	91-94	_____	<b>644-1087</b>
CR80R	86-91	_____	<b>644-1025</b>
CR80R	92-02	<b>645-1055</b>	<b>644-1085</b>
CR80RB	00-02	<b>645-1055</b>	<b>644-1085</b>
CRF80	04-12	_____	<b>644-1086</b>
XR80R	93-03	_____	<b>644-1086</b>
CRF100	04-09	_____	<b>644-1088</b>
XR100R	92-03	_____	<b>644-1088</b>
CR125R	1986	_____	<b>644-1026</b>
CR125R	90-99	<b>645-1057</b>	<b>644-1089</b>
XL185S	79-83	<b>645-1051</b>	_____
XR185	1979	<b>645-1051</b>	_____
TLR200 Reflex	86-87	<b>645-1051</b>	_____
TR200 Fatcat	86-87	<b>645-1058</b>	<b>644-1035</b>
XL200R	83-84	<b>645-1051</b>	<b>644-1028</b>
XR200	80-84	<b>645-1051</b>	<b>644-1028</b>
XR200R	81-83	<b>645-1051</b>	<b>644-1028</b>
XR200R	84-85	<b>645-1008</b>	<b>644-1028</b>
XR200R	86-88	<b>645-1051</b>	<b>644-1028</b>
XR200R	90-91	<b>645-1051</b>	<b>644-1028</b>
XR200R	94-02	<b>645-1059</b>	_____
CR250R	1984	<b>645-1009</b>	_____
CR250R	89-91	_____	<b>644-1083</b>
CR250R	92-01	<b>645-1060</b>	<b>644-1092</b>
CR250R	05-07	_____	<b>HG-1105</b>
XL250S	78-81	_____	<b>644-1009</b>
XL250R	82-83	_____	<b>644-1009</b>
XL250R	84-87	<b>645-1008</b>	<b>644-1039</b>
XR250	79-80	_____	<b>644-1009</b>
XR250L	91-96	<b>645-1008</b>	<b>644-1039</b>
XR250R	81-82	_____	<b>644-1009</b>
XR250R	84-95	<b>645-1008</b>	<b>644-1039</b>
XR250R	96-04	<b>645-1008</b>	<b>644-1039</b>
XR400R	96-01	<b>645-1061</b>	<b>644-1094</b>
CR500R	1984	<b>645-1014</b>	<b>644-1012</b>
CR500R	85-86	<b>645-1032</b>	<b>644-1010</b>
CR500R	89-01	<b>645-1062</b>	<b>644-1095</b>
XR500R	83-84	<b>645-1017</b>	_____
XL600R	83-87	<b>645-1017</b>	<b>644-1040</b>
XR600R	85-87	<b>645-1017</b>	<b>644-1040</b>
XR600R	88-00	<b>645-1017</b>	<b>644-1097</b>
XR650L	93-12	<b>645-1017</b>	<b>644-1081</b>

# Base & Head Gaskets



609-880

## Kawasaki Street

(Requires qt 2 for applications in red - Street only)

Model	Year	Base Gskt	Head Gskt
EN450A1-A6 LTD 454	85-90	645-4029	644-4030
EN500A1-A7 Vulcan 500	90-96	645-4029	644-4030
EN500C1-D9F Vulcan 500 LTD	96-09	645-4029	644-4030
EX500A1-A7	87-93	645-4029	644-4030
EX500D1/D2/D3 Ninja 500	94-96	645-4029	644-4030
EX500D4-D9F Ninja 500R	97-09	645-4029	644-4030
ZL600A1/A2 Eliminator	86-87	645-4034	644-4035
ZL600B2/B3 Eliminator 600	96-77	645-4034	644-4035
ZX600A1/A2/A3 Ninja 600R	85-87	645-4034	644-4035
ZX600B1 Ninja 600RX	1987	645-4034	644-4035
ZX600C1-C10 Ninja 600R	88-97	645-4034	644-4035
KZ650H1/H2/H3 CSR	81-83	645-4013	_____
KZ700A1	1984	645-4013	_____
ZN700A1/A2 LTD Shaft	84-85	645-4013	_____
KZ750E1/E2/E3	80-82	645-4013	644-4015
KZ750F1	1983	645-4013	644-4015
KZ750H1/H2/H3/H4 LTD	80-83	645-4013	644-4015
KZ750L3	1983	645-4013	644-4015
KZ750N1/N2 Spectre	82-83	645-4013	644-4015
KZ750R1 GPz	1982	645-4013	644-4015
ZR750C1/C2/C3	91-92	645-4013	_____
ZX750A1/A2/A3 GPz	83-85	645-4013	644-4015
ZX750E1/E2 GPz Turbo	84-85	645-4013	_____
Z1900 (1 piece head gasket)	1973	645-4022	609-880
Z1A/B-900	74-75	645-4022	644-4021
KZ900A4/A5	76-77	645-4022	644-4021
KZ900B1 LTD	1976	645-4022	644-4021
ZL900A1/A2 Eliminator	85-86	645-4041	_____
ZX900A1/A2/A3 Ninja 900	84-86	645-4041	_____
KZ1000A1/A2/A2A	77-78	645-4022	644-4022
KZ1000A3/A3A/A4 MKII	79-80	645-4022	644-4022
KZ1000B1/B2 LTD/B3/B4 LTD	77-80	645-4022	644-4022
KZ1000C1/C1A/C2/C3/C4 Police	78-81	645-4022	644-4022
KZ1000D1 Z1R	1978	645-4022	644-4022
KZ1000D3 Z1R	1980	645-4022	644-4022
KZ1000E1/E2 Shaft ST	79-80	645-4022	644-4022
KZ1000G1 LTD Classic	1980	645-4022	644-4022
KZ1000J1/J2/J3	81-83	645-4016	644-4023
KZ1000K1/K2 LTD	81-82	645-4016	644-4023
KZ1000M1/M2 CSR	81-82	645-4016	644-4023
KZ1000P1-P21 Police	82-02	645-4016	644-4023
KZ1000P24 Police	2005	645-4016	644-4023
KZ1000R1/R2 Replica	82-83	645-4016	644-4023
ZG1000A1-A6F Concours	86-06	645-4041	_____
ZL1000A1 Eliminator	1987	645-4041	_____
ZX1000A1/A2 Ninja 1000R	86-87	645-4041	_____
ZX1000B1/B2/B3 Ninja ZX-10	88-90	645-4041	_____
KZ1100A1/A2/A3 Shaft	81-83	645-4016	644-4024
KZ1100B1/B2 GPz	81-82	645-4016	644-4024
KZ1100D1/D2 Spectre	82-83	645-4016	644-4024
KZ1100L1 LTD Shaft	1983	645-4016	644-4024
ZN1100B1/B2 LTD Shaft	84-85	645-4016	644-4016
ZR1100C3/C4 ZRX1100	99-00	645-4041	644-4047
ZX1100A1/A2 GPz	83-84	645-4016	644-4016
ZX1100C1-C4 Ninja ZX-11	90-93	645-4041	644-4047
ZX1100D1-D9 Ninja ZX-11	93-01	645-4041	644-4047
ZX1100E1/E2/E3 GPz	95-97	645-4041	644-4047
ZX1100F1 GPz (ABS)	1996	645-4041	644-4047

## Kawasaki ATV

Model	Year	Base Gskt	Head Gskt
KLF220A1-A15 Bayou 220	88-02	645-4046	644-4051
KSF250A1-A17 Mojave 250	87-03	645-4030	644-4029
KSF250A18 KFX250 Mojave	2004	645-4030	644-4029
KEF300A1-A6 Lakota 300	95-00	645-4048	644-4053
KEF300B1/B2/B3 Lakota Sport	01-03	645-4048	644-4053
KLF300A1/A2 Bayou	86-87	645-4048	_____
KLF300B1-B17 Bayou 300	88-04	645-4048	644-4053
KLF300C1-C17 Bayou 300 4x4	89-05	645-4048	644-4053
KVF300A1-A4 Prairie 300 4x4	99-02	645-4048	644-4053
KVF300B1/B2/B3/B4 Prairie 300	99-02	645-4048	644-4053
KLF400B1-B7 Bayou 400 4x4	93-99	645-4049	_____

## Kawasaki Offroad

Model	Year	Base Gskt	Head Gskt
KX60A1/A2	83-84	645-4001	_____
KX60B1-B15	85-99	645-4001	644-4001
KX60B16/B17/B18/B19	00-03	_____	644-4001
KDX80B3	1983	645-4001	_____
KDX80C1/C2/C3/C4 /C5	84-88	645-4001	_____
KX80R1-R7	91-97	645-4044	644-4039
KX80T1/T2/T3/T4	91-94	645-4044	644-4039
KX80W1/W2/W3	98-00	_____	644-4039
KX100B5/B6/B7	95-97	645-4044	644-4039
KX100D1-D5	01-05	_____	HG-4049
KX100 D6F-D8F	06-08	_____	HG-4049
KX100 D9F-DCF	09-12	_____	HG-4049
KX125C1/D2/E1	84-86	645-4004	_____
KX125F1/G1	88-89	645-4036	_____
KX125H1/H2	90-91	645-4037	644-4041
KX125K2/K3/K4	95-97	645-4045	644-4050
KX125L1/L2/L3/L4	99-02	_____	644-4050
KL250D2-D22 KLR250	85-05	645-4030	644-4029
KX250D2	1986	645-4023	644-4045
KX250F1/G1	88-89	645-4039	644-4045
KX250H1/H2	90-91	645-4040	644-4045
KX250K2/K3/K4/K5	95-98	645-4047	644-4052
KX250L1/L2/L3/L4	99-02	645-4047	644-4052
KX250M1	2003	645-4047	644-4052
KX500A1/A2/B1	83-85	645-4011	_____
KX500E1-E14	89-02	645-4050	644-4055

## Suzuki Street

Model	Year	Base Gskt	Head Gskt
GSF600ST-SK5 Bandit	96-03	_____	_____
GSX600FJ-FY Katana	88-00	_____	_____
GSX600FK1-FK6 Katana	01-06	_____	_____
GSX750FK-FK6 Katana	89-06	_____	_____
GS-XR750G/H	86-87	_____	644-3033
GS-XR750J/K	88-89	_____	644-3033
GS-XR750L	1990	_____	_____
GS1000C/EC/N	78-79	645-3004	644-3003
GS1000EN/ET	80-81	645-3004	644-3003
GS1000GT/GX	80-81	645-3004	644-3003
GS1000GLT/GLX	80-81	645-3004	644-3003
GS1000LN	1979	645-3004	644-3003
GS1000SN/ST	79-80	645-3004	644-3003
GS1100ED/ESD	1983	645-3005	644-3004
GS1100SD Katana	1983	645-3005	644-3004
GS1100GKZ/GKD/	82-83	_____	644-3005
GS1100GZ/GLZ/GD/GLD	82-83	_____	644-3005
GSX1100FJ-FN Katana	88-92	_____	_____
GSX1100GM/GN/GP Shaft	91-93	_____	_____
GSX-R1100G/H/J	86-88	_____	_____
GSX-R1100K/L/M/N	89-92	645-3044	_____
GSX-R1100WP-/MW	93-98	_____	_____

## Suzuki ATV

Model	Year	Base Gskt	Head Gskt
LT-F230G/H	86-87	645-3010	_____
LT230EH/EJ/EK/EL	87-90	645-3010	_____
LT230EM/EN/EP	91-93	645-3010	_____
LT230GEF/GEG	85-86	645-3010	_____
LT230SF/SG/SH/SJ	85-88	645-3010	_____
LT-4WDH/J/K/L Quadrunner	87-90	645-3010	_____
LT-4WDM/N P/R Quadrunner	91-94	645-3010	_____
LT-4WDS Quadrunner	1995	645-3010	_____
LT-4WDT/V/W Quadrunner	96-98	645-3010	_____
LT-F250J/K/L/M/N/P	88-93	645-3010	_____
LT-F250R/S/T/V/W/X/Y/K1	94-01	645-3010	_____
LT-F250 K2-L2 Ozark	02-12	645-3010	_____
LT-F250FX/FY/FK1/FK2 Quad	99-02	645-3010	_____
LT250RH/RJ/RK Quad Racer	87-89	645-3049	644-3055
LT250RL/RM/RN Quad Racer	90-92	645-3049	644-3055
LT-Z250 K4-K9 QuadSport	04-09	645-3010	_____
LT500RJ/RK/RL Quad Racer	88-90	645-3055	644-3064

## Suzuki Dual Sport & Offroad

Model	Year	Base Gskt	Head Gskt
RM60K3	2003	_____	644-4001
RM125K/L/M	89-91	645-3046	_____
RM125N/P/R/S/T	92-96	645-3046	_____
RM125V/W/X/Y	97-00	645-3046	_____
RM125K1/K2/K3	01-03	645-3046	_____
DR200SE T-K3 Dual Sport	96-03	645-3010	_____
DR250L/M/N/P Offroad	90-93	645-3053	_____
DR250SL/SM/SN	90-92	645-3053	_____
DR250SEP/SER/SES Dual Sport	93-95	645-3053	_____
RM250E/F	84-85	645-3015	644-3013
DR350L-X Offroad	90-99	645-3053	_____
DR350SL/SM/SN/SP Dual Sport	90-93	645-3053	_____
DR350SER-SEX Dual Sport	94-99	645-3053	_____

## Yamaha Street

Model	Year	Base Gskt	Head Gskt
QT50		645-2001	_____
DT125		645-2046	_____
RD125LC (non USA model)	82-84	645-2048	_____
TW200 Trailway	88-96	645-2026	644-2024
TW200 Trailway	97-12	645-2027	644-2024
RD350LC (non USA model)	1985	645-2005	644-2005
RZ350L/N/NC/NCII	83-84	645-2005	644-2005
RD400C/D/E/F	76-79	645-2004	644-2004
SR500E/F/G/H	78-81	645-2035	644-2035
XT500C/D/E/F/G/H	76-82	645-2035	644-2035
FZR600W/WC/A/AC	89-90	645-2051	_____
FZR600RA/RAC-RL/RLC	90-99	645-2051	_____
XS650B/C/D/E/F/2F	76-79	645-2036	644-2036
XS650G/H Special	80-81	645-2036	644-2036
XS650SE/SF/SG/SH Special	78-81	645-2036	644-2036
XS650SJ/SK Heritage Special	82-83	645-2036	644-2036
FZ700T/TC	1987	645-2041	_____
FZ750N/S/SC	85-86	645-2041	_____
FZ750U/UC	1988	645-2041	_____
FZR750RT/RU	87-88	645-2041	_____
YZF750RF/RFC	1994	645-2061	644-2066
YZF750RH/RHC/RJ/RJC/RK/RKC	96-98	645-2061	644-2066
FZR1000U/UC	1988	645-2049	_____
FZR1000	92-95	645-2052	_____
GTS1000	93-94	645-2052	_____
FJ1100L/LC/N/NC	84-55	645-2038	_____
XS1100J Maxim	1982	_____	_____
XS1100E/F/G/H	78-81	_____	644-2026
XS1100LG/LH Midnight Special	80-81	_____	644-2026
XS1100SF/SG/SH Special	79-81	_____	644-2026
FJ1200 S/SC, T/TC	86-87	_____	644-2063
FJ1200W/WC-D/DC	89-92	_____	644-2063
FJ1200A D/DC, E/EC	92-93	_____	644-2063

## Yamaha ATV

Model	Year	Base Gskt	Head Gskt
YFM200N Moto-4	1985	645-2026	644-2024
YFM200DXS/DXT Moto-4	86-87	645-2026	644-2024
YFM200DXU/DXW Moto-4	88-89	645-2026	644-2024
YFS200U-T/SEV Blaster	88-06	645-2048	644-2064
YTM200K/L/N Tri-Moto	83-84	645-2026	644-2024
YTM200N Tri-Moto	1985	645-2026	644-2024
YTM200EK/EL/ERN Tri-Moto	83-85	645-2026	644-2024
YTM225DRN/DRS Tri-Moto	85-86	645-2027	644-2025
YTM225DXK/DXL/DXN Tri-Moto	83-85	645-2027	644-2025
YFB250D/E/F/G/H/J Timberwolf	92-97	645-2027	_____
YFB250FWF-FWM/MC 4WD	94-00	645-2027	_____
YFB250UH/UJ/UK Timberwolf	96-98	645-2027	_____
YFM250M/MC Bear Tracker	2000	645-2027	_____
YFM250XL/XLC/XM/XMC	99-00	645-2027	_____
Beartracker			
YFM250XN/XHN/XP/XR/XS	01-04	645-2027	_____
Beartracker			
YFM350S Raptor	2004	645-2057	644-2046
YFM350RSET/RESV Raptor 350	05-06	645-2057	644-2046
YFM350R T-Y Raptor	05-09	645-2057	644-2046
YFM350ERD-ERG Moto-4	92-95	645-2057	644-2046
YFM350FAS Bruin 350 Auto 4x4	2004	645-2057	644-2046
YFM350FAHS Bruin 350 Auto 4x4	2004	645-2057	644-2046
Hardwood Camo			
YFM350FHL/FHLC Wolverine	1999	645-2057	644-2046
YFM350FWD-FWJ Big Bear	92-97	645-2057	644-2046
YFM350FWBJ-FWL/LC Big Bear	97-99	645-2057	644-2046
YFM350FXP/FXR Wolverine	02-03	645-2057	644-2046
YFZ350T/U/W/A/B Banshee	87-91	645-2058	644-2048
Yfz350D-V Banshee Limited	92-06	_____	644-2048
YFZ350LER/LES Banshee Limited	03-04	_____	644-2048
YFZ350RB Banshee Limited	2003	_____	644-2048
YFZ350SET/SEV Banshee SE	05-06	_____	644-2048
YFZ350SPV Banshee SP	2006	_____	244-2048
YFM400S Big Bear 400 2WD	2004	645-2057	644-2046
YFM400P Big Bear 400 2WD	2002	645-2057	644-2046
YFM400FM/FMC Big Bear 4WD	2000	645-2057	644-2046
YFM400FP Big Bear 4WD	2002	645-2057	644-2046
Real Tree X-tra			
YFM400FHM Big Bear Buckmaster	2000	645-2057	644-2046
YFM400FHP Big Bear 400 4WD	2002	645-2057	644-2046
YFM400FWE-FWL/LC Kodiak	93-99	645-2057	644-2046
YFM400FWR Big Bear	2003	645-2057	644-2046
YFM400FWM/MC/N Big Bear	00-01	645-2057	644-2046
YFM400FWMH/MC/N Big Bear	00-01	645-2057	644-2046
Buckmaster 4WD			
YFM400HP Big Bear 2WD	2002	645-2057	644-2046
Real Tree X-tra			
YFM400NM/NMC/N Big Bear	00-01	645-2057	644-2046
YFM400NR Big Bear 2WD	2003	645-2057	644-2046
YFM400NHN Big Bear 2WD	2001	645-2057	644-2046
YFM400FS-FV Big Bear 400 4WD	04-06	645-2057	644-2046

## Yamaha Dual Sport & Offroad

Model	Year	Base Gskt	Head Gskt
PW50A-V Y-Zinger	90-12	645-2001	644-2001
PW80 G-V Y-Zinger	95-10	645-2063	_____
YZ80N/S/T/U/W/A/B/D	85-92	_____	644-2008
YZ125K/L/N	83-85	645-2010	644-2012
YZ125F1/G1/H1/J1	94-97	645-2066	_____
BW200N/S Big Wheel	85-86	645-2026	644-2024
BW200ES/ET/EU Big Wheel	86-88	645-2026	644-2024
TW200T/TC-H/HC Trailway	87-96	645-2026	644-2024
TW200J/JC-M/MC Trailway	97-12	645-2026	644-2024
XT200J/K/KC Dual Sport	82-83	645-2026	644-2024
WR250ZH/ZJ	96-97	645-2068	_____
IT490K/L	83-84	645-2012	_____
YZ490J/K/L/N/S/T/U/W/A	82-90	645-2012	_____
TT500C/D/E/F/G/H	76-81	645-2035	_____
XT500C/D/E/F/G/H Dual Sport	76-81	645-2035	_____
TT600K/L/N	83-85	645-2014	_____
XT600L/LC-W/WC	84-89	645-2014	_____

# Exhaust Pipe Gaskets

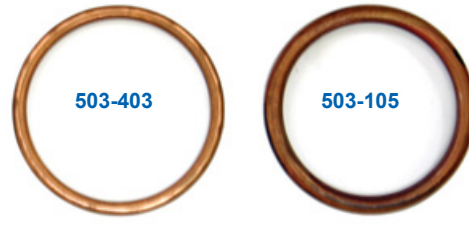
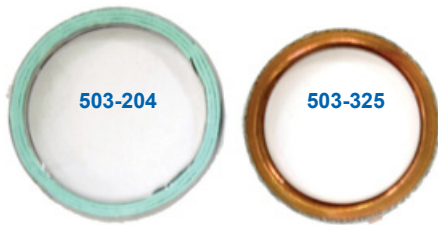

## Vesrah Exhaust Pipe Gaskets

Quality Vesrah exhaust pipe gaskets exceed OEM specifications.  
Sold each. *Made in Japan.*

### Honda Street

Model	Year	Vesrah Ref.	Order No.
XL75	77-79	VE-1002	503-102
XL80S	80-85	VE-1002	503-102
CT90 Trail 90	66-68	VE-1002	503-102
CT90K1-K6 Trail 90	69-75	VE-1002	503-102
CT90 Trail 90	76-79	VE-1002	503-102
CB100K0/K1/K2 Super Sport 100	70-72	VE-1003	503-103
CL100K0/K1/K2 Scrambler 100	70-72	VE-1003	503-103
CL100S/S2/S3 Scrambler 100S	71-73	VE-1003	503-103
SL100K0/K1/K2/K3 Motosport 100	70-73	VE-1003	503-103
XL100/K1	74-75	VE-1003	503-103
XL100	76-78	VE-1003	503-103
XL100S	79-85	VE-1002	503-102
CB125S/S1/S2	73-75	VE-1003	503-103
CB125S	76-82	VE-1003	503-103
CB125TT	1990	VE-1003	503-103
CL125S/S1	73-74	VE-1003	503-103
NX125	88-90	VE-1003	503-103
SL125/K1/K2 Motor Sport	71-73	VE-1003	503-103
XL125/K1	74-75	VE-1003	503-103
CM185T Twinstar	1979	VE-1003	503-103
XL185S	79-83	VE-1003	503-103
CM200T Twinstar	80-82	VE-1003	503-103
TLR200 Reflex	86-87	VE-1003	503-103
XL200R	83-84	VE-1003	503-103
CB250 Nighthawk	91-05	VE-1003	503-103
CH250 Elite 250	85-87	VE-1003	503-102
CM250C Custom	82-83	VE-1003	503-103
CMX250C Rebel	85-87	VE-1003	503-103
CMX250C Rebel	96-97	VE-1003	503-103
CMX250C Rebel	99-07	VE-1003	503-103
CMX250C2 Rebel	99-00	VE-1003	503-103
CMX250CD Rebel L	1986	VE-1003	503-103
NX250	88-90	VE-1005	503-105
VTR250 Interceptor	88-90	VE-1008	503-108
XL250/K1/K2 Motor Sport	73-75	VE-1006	503-106
XL250 Motor Sport	1976	VE-1006	503-106
XL250R	82-83	VE-1003	503-103
XL250R	84-87	VE-1031	503-131
XR250L	91-96	VE-1031	503-131
CB350F Super Sport	73-74	VE-1002	503-102
CB350G	1973	VE-1006	503-106
CB350K2-K4 Super Sport	70-72	VE-1006	503-106
CL350K2-K5 Scrambler	70-73	VE-1006	503-106
SL350/K1/K2 Motor Sport	70-72	VE-1006	503-106
XL350/K1	74-75	VE-1012	503-112
XL350	76-78	VE-1012	503-112
XL350R	84-85	VE-1003	503-103
CB360G	1974	VE-1006	503-106
CB360K	1974	VE-1006	503-106
CB360T	75-76	VE-1006	503-106
CJ360T	76-77	VE-1006	503-106

### Honda Street

Model	Year	Vesrah Ref.	Order No.
CL360/K1	74-75	VE-1006	503-106
CB400A Automatic	1978	VE-1006	503-108
CB400F Super Sport	75-77	VE-1002	503-102
CB400F CB1	89-90	VE-1008	503-108
CB400T Hawk	80-81	VE-1008	503-108
CB400T1 Hawk	78-79	VE-1008	503-108
CB400TII Hawk	78-79	VE-1008	503-108
CM400A Automatic	79-81	VE-1008	503-108
CM400C Custom	1981	VE-1008	503-108
CM400E	80-81	VE-1008	503-108
CM400T	79-81	VE-1008	503-108
CB450K	69-74	VE-1012	503-112
CB450SC Nighthawk	82-83	VE-1008	503-108
CB450SC Nighthawk	1985	VE-1008	503-108
CB450T Hawk	1982	VE-1008	503-108
CM450A Automatic	82-83	VE-1008	503-108
CM450C Custom	1982	VE-1008	503-108
CM450E	82-83	VE-1008	503-108
CMX450C Rebel	86-87	VE-1008	503-108
CB500T 2-cylinder	75-76	VE-1012	503-112
CB500/K1/K2 (4-cylinder)	71-73	VE-1003	503-103
CX500	78-79	VE-1006	503-106
CX500C Custom	79-82	VE-1006	503-106
CX500D Deluxe	79-81	VE-1006	503-106
FT500 Ascot	82-83	VE-1005	503-105
GB500	89-90	VE-1003	503-103
GL500 Silverwing	81-82	VE-1006	503-106
GL500I Silverwing Interstate	81-82	VE-1006	503-106
VF500C Magna	84-85	VE-1003	503-103
VF500F Interceptor	84-86	VE-1006	503-103
VT500C Shadow	83-86	VE-1008	503-108
VT500FT Ascot	83-84	VE-1006	503-108
XL500S Dual Sport	79-81	VE-1003	503-103
CB550F Super Sport	75-77	VE-1003	503-103
CB550/K1	74-76	VE-1003	503-103
CB550K	77-78	VE-1003	503-103
CB550SC Nighthawk	1983	VE-1008	503-108
CB600F 599	2004	VE-1008	503-108
CB600F 599	2006	VE-1008	503-108
CBR600F Hurricane	87-90	VE-1008	503-108
CBR600F2 Hurricane	91-94	VE-1008	503-108
CBR600F3 Hurricane	95-98	VE-1008	503-108
CBR600F4 Hurricane	99-05	VE-1008	503-108
CBR600RR	03-07	VE-1008	503-108
CBR600SE	1998	VE-1008	503-108
CBR600SJR Smokin Joe Replica	1996	VE-1008	503-108
VT600C Shadow	88-89	VE-1005	503-105 (R)
		VE-1008	503-108 (F)
VT600C Shadow VLX	91-06	VE-1005	503-105 (R)
		VE-1008	503-108 (F)
VT600CD Shadow VLX Deluxe	93-06	VE-1005	503-105 (R)
		VE-1008	503-108 (F)
VT600CD2 Shadow VLX	99-00	VE-1005	503-105 (R)
		VE-1008	503-108 (F)
XL600R	83-87	VE-1003	503-103
XL600V Transalp	89-90	VE-1008	503-108



## Honda Street

Model	Year	Vesrah Ref.	Order No.
CB650	79-82	VE-1008	<b>503-108</b>
CB650C Custom	80-81	VE-1008	<b>503-108</b>
CB650SC Nighthawk	82-85	VE-1008	<b>503-108</b>
NT650 Hawk GT	88-90	VE-1005	<b>503-105(R)</b>
		VE-1008	<b>503-108(F)</b>
NX650	88-89	VE-1003	<b>503-103</b>
XR650L Dual Sport	93-06	VE-1008	<b>503-103</b>
CB700SC Nighthawk	84-86	VE-1005	<b>503-105</b>
VF700C Magna	84-87	VE-1003	<b>503-103</b>
VF700F Interceptor	84-85	VE-1003	<b>503-103</b>
VF700S Sabre	84-85	VE-1003	<b>503-103</b>
VFR700F/F2 Interceptor	86-87	VE-1003	<b>503-103</b>
VT700C Shadow	84-85	VE-1012	<b>503-112</b>
CB750 Nighthawk	91-03	VE-1005	<b>503-105</b>
CB750A Automatic	76-78	VE-1005	<b>503-105</b>
CB750C Custom	80-82	VE-1005	<b>503-105</b>
CB750F Super Sport	76-78	VE-1005	<b>503-105</b>
CB750F Super Sport	79-82	VE-1005	<b>503-105</b>
CB750K0/K1/K2/K3/K4/K5	69-75	VE-1005	<b>503-105</b>
CB750/K	76-78	VE-1005	<b>503-105</b>
CB750K	79-82	VE-1005	<b>503-105</b>
CB750L LTD	1979	VE-1005	<b>503-105</b>
CB750SC Nighthawk	82-83	VE-1005	<b>503-105</b>
RVF750R (RC45)	1994	VE-1003	<b>503-103</b>
VF750C V45 Magna	82-83	VE-1003	<b>503-103</b>
VF750C V45 Magna	1988	VE-1003	<b>503-103</b>
VF750C Magna	94-03	VE-1003	<b>503-103</b>
VF750C2 Magna Deluxe	97-00	VE-1003	<b>503-103</b>
VF750CD Magna Deluxe	95-98	VE-1003	<b>503-103</b>
VF750F Interceptor	83-84	VE-1003	<b>503-103</b>
VF750S V45 Sabre	82-83	VE-1003	<b>503-103</b>
VFR750F Interceptor	1986	VE-1003	<b>503-103</b>
VFR750F	90-97	VE-1003	<b>503-103</b>
VFR750R (RC30)	1990	VE-1003	<b>503-103</b>
VT750C Shadow	1983	VE-1012	<b>503-112</b>
VT750C Shadow	98-00	VE-1005	<b>503-105</b>
VT750C Shadow Aero	04-06	VE-1005	<b>503-105</b>
VT750CA Shadow Aero	04-06	VE-1005	<b>503-105</b>
VT750CD Shadow Deluxe	98-01	VE-1005	<b>503-105</b>
VT750CD2 Shadow Deluxe	98-01	VE-1005	<b>503-105</b>
VT750CDA Shadow ACE 750 Deluxe	02-03	VE-1005	<b>503-105</b>
VT750CDB Shadow ACE 750 Deluxe	02-03	VE-1005	<b>503-105</b>
VT750CDC Shadow ACE 750 Deluxe	02-03	VE-1005	<b>503-105</b>
VT750CDD Shadow ACE 750 Deluxe	02-03	VE-1005	<b>503-105</b>
VT750DC Shadow Spirit 750	01-02	VE-1005	<b>503-105</b>
VT750DCA Shadow Spirit 750	2003	VE-1005	<b>503-105</b>
VT750DCA Shadow Spirit 750	05-06	VE-1005	<b>503-105</b>
VT750DCB Shadow Spirit 750	2003	VE-1005	<b>503-105</b>
VT750DCB Shadow Spirit 750	05-06	VE-1005	<b>503-105</b>
PC800 Pacific Coast	89-90	VE-1012	<b>503-112</b>
PC800 Pacific Coast	94-98	VE-1012	<b>503-112</b>
VFR800 Interceptor	02-07	VE-1003	<b>503-103</b>
VFR800A Interceptor ABS	02-07	VE-1003	<b>503-103</b>
VFR800FI Interceptor	98-01	VE-1003	<b>503-103</b>
VT800C Shadow	1988	VE-1012	<b>503-112</b>
CB900C Custom	80-82	VE-1005	<b>503-105</b>
CB900F Super Sport	81-82	VE-1005	<b>503-105</b>
CB900F 919	02-07	VE-1008	<b>503-108</b>
CBR900RR	93-99	VE-1008	<b>503 108</b>
CBR929RE	2001	VE-1005	<b>503 105</b>
CBR929RR	00-01	VE-1005	<b>503-105</b>
CBR954RR	02-03	VE-1005	<b>503-105</b>
CB1000	94-95	VE-1005	<b>503-105</b>
CB1000C Custom	1983	VE-1005	<b>503-105</b>

## Honda Street

Model	Year	Vesrah Ref.	Order No.
CBR1000F Hurricane	87-88	VE-1005	<b>503-105</b>
CBR1000F Hurricane	90-91	VE-1005	<b>503-105</b>
CBR1000F Hurricane	93-96	VE-1005	<b>503-105</b>
GL1000 Goldwing	75-79	VE-1006	<b>503-106</b>
GL1000L Goldwing LTD	1976	VE-1006	<b>503-106</b>
VF1000F Interceptor	1984	VE-1008	<b>503-108</b>
VF1000R	85-86	VE-1008	<b>503-108</b>
VTR1000F Super Hawk	98-05	VE-1012	<b>503-112</b>
CB1100F Super Sport	1983	VE-1005	<b>503-105</b>
CBR1100XX Blackbird	97-03	VE-1005	<b>503-105</b>
GL1100 Goldwing	80-83	VE-1006	<b>503-106</b>
GL1100A Goldwing Aspencade	82-83	VE-1006	<b>503-106</b>
GL1100I Goldwing Interstate	80-83	VE-1006	<b>503-106</b>
ST1100	91-02	VE-1008	<b>503-108</b>
ST1100A (ABS)	92-02	VE-1008	<b>503-108</b>
VF1100C V65 Magna	83-86	VE-1008	<b>503-108</b>
VF1100S V65 Sabre	84-85	VE-1008	<b>503-108</b>
VT1100C Shadow	85-90	VE-1012	<b>503-112</b>
VT1100C Shadow 1100	92-96	VE-1012	<b>503-112</b>
VT1100C Shadow Spirit	97-06	VE-1012	<b>503-112</b>
VT1100C2 Shadow ACE	95-99	VE-1012	<b>503-112</b>
VT1100C2 Shadow Sabre	00-06	VE-1012	<b>503-112</b>
VT1100C2-2 Shadow ACE	1997	VE-1012	<b>503-112</b>
VT1100C3 Shadow Aero	98-02	VE-1012	<b>503-112</b>
VT1100D2 Shadow ACE	1999	VE-1012	<b>503-112</b>
VT1100T ACE Tourer	98-01	VE-1012	<b>503-112</b>
GL1200 Goldwing	1984	VE-1006	<b>503-106</b>
GL1200A Goldwing Aspencade	84-87	VE-1006	<b>503-106</b>
GL1200I Goldwing Interstate	84-87	VE-1006	<b>503-106</b>
GL1200L Goldwing LTD	1985	VE-1006	<b>503-106</b>
GL1200SE-i Goldwing SEi	1986	VE-1006	<b>503-106</b>
ST1300	03-07	VE-1008	<b>503-108</b>
ST1300A ABS	03-07	VE-1008	<b>503-108</b>
GL1500 Goldwing	88-90	VE-1003	<b>503-103</b>
GL1500A Goldwing Aspencade	91-99	VE-1003	<b>503-103</b>
GL1500C Valkyrie	97-00	VE-1003	<b>503-103</b>
GL1500C Valkyrie	2003	VE-1003	<b>503-103</b>
GL1500CDValkyrie	01-03	VE-1003	<b>503-103</b>
GL1500CF Valkyrie Interstate	99-01	VE-1003	<b>503-103</b>
GL1500CT Valkyrie Tourer	97-00	VE-1003	<b>503-103</b>
GL1500I Goldwing Interstate	91-96	VE-1003	<b>503-103</b>
GL1500SE Goldwing SE	90-00	VE-1003	<b>503-103</b>
GL1800 Goldwing	01-07	VE-1003	<b>503-103</b>
GL1800A Goldwing Aspencade	01-07	VE-1003	<b>503-103</b>
NRX1800DA Valkyrie Rune	2004	VE-1003	<b>503-103</b>
NRX1800DB Valkyrie Rune	2004	VE-1003	<b>503-103</b>
NRX1800EA Valkyrie Rune	2004	VE-1003	<b>503-103</b>
NRX1800EB Valkyrie Rune	2004	VE-1003	<b>503-103</b>
VTX1800C	02-07	VE-1012	<b>503-112</b>
VTX1800C1/C2/C3	2005	VE-1012	<b>503-112</b>
VTX1800F1/F2/F3	05-07	VE-1012	<b>503-112</b>
VTX1800N1/N2/N3	2005	VE-1012	<b>503-112</b>
VTX1800N	06-07	VE-1012	<b>503-112</b>
VTX1800R	02-03	VE-1012	<b>503-112</b>
VTX1800R1/R2/R3	04-05	VE-1012	<b>503-112</b>
VTX1800S	02-03	VE-1012	<b>503-112</b>
VTX1800S1/S2/S3	04-05	VE-1012	<b>503-112</b>
VTX1800T	2007	VE-1012	<b>503-112</b>



# Exhaust Pipe Gaskets

## Honda ATV

Model	Year	Vesrah Ref.	Order No.
ATC90/K1/K2/K3	70-75	VE-1002	503-102
ATC90	76-78	VE-1002	503-102
ATC110	79-85	VE-1002	503-102
ATC125M	86-87	VE-1003	503-103
TRX125 Fourtrax	87-88	VE-1003	503-103
ATC185	1980	VE-1003	503-103
ATC185S	81-83	VE-1003	503-103
ATC200	81-83	VE-1003	503-103
ATC200E	82-84	VE-1003	503-103
ATC200ES Big Red	82-84	VE-1003	503-103
ATC200M	84-85	VE-1003	503-103
ATC200S	84-86	VE-1003	503-103
ATC200X	83-87	VE-1003	503-103
TRX200 Fourtrax	1984	VE-1003	503-103
TRX200 Fourtrax 200	90-91	VE-1003	503-103
TRX200D Fourtrax Type II	91-97	VE-1003	503-103
TRX200SX Fourtrax	86-88	VE-1003	503-103
ATC250ES Big Red	85-87	VE-1008	503-108
ATC250SX	85-87	VE-1008	503-108
TRX250 Fourtrax	85-87	VE-1008	503-108
TRX250 Recon	97-01	VE-1008	503-108
TRX250EX Sportrax 250EX	01-08	VE-1003	503-103
TRX250TE Fourtrax Recon ES	02-06	VE-1003	503-103
TRX250TM Fourtrax Recon	02-06	VE-1003	503-103
TRX250X Fourtrax 250X	87-88	VE-1008	503-108
TRX250X Fourtrax 250X	91-92	VE-1008	503-108
TRX300 Fourtrax 300	88-00	VE-1008	503-108
TRX300EX Fourtrax 300 EX	93-00	VE-1008	503-108
TRX300EX Sportrax 300 EX	01-08	VE-1008	503-108
TRX300FW Fourtrax 4x4	1988	VE-1008	503-108
TRX300FW Fourtrax 4x4	90-00	VE-1008	503-108
ATC350X	85-86	VE-1003	503-103
TRX350 Fourtrax 4x4	86-87	VE-1003	503-103
TRX350D Fourtrax Foreman 4x4	87-89	VE-1003	503-103
TRX350FE Rancher 4x4 ES	00-06	VE-1008	503-108
TRX350FM Rancher 4x4	00-06	VE-1008	503-108
TRX350TE Rancher ES	00-06	VE-1008	503-108
TRX350TM Fourtrax Rancher	00-06	VE-1008	503-108
TRX400EX Fourtrax 400 EX	99-00	VE-1008	503-103
TRX400EX Sportrax 400 EX	01-05	VE-1003	503-103
TRX400FA Fourtrax Rancher AT	04-07	VE-1008	503-108
TRX400FGA Fourtrax Rancher AT	04-07	VE-1008	503-108
TRX400FM Fourtrax Foreman	2002	VE-1008	503-108
TRX400FW Fourtrax Foreman	95-01	VE-1008	503-108
TRX400FW Fourtrax Foreman	2003	VE-1008	503-108
TRX450ES Fourtrax Foreman ES	98-01	VE-1008	503-108
TRX450FE Fourtrax Foreman ES	02-04	VE-1008	503-108
TRX450FM Fourtrax Foreman S	02-04	VE-1008	503-108
TRX450S Fourtrax Foreman S	98-01	VE-1008	503-108
TRX500FA Fourman Rubicon	01-07	VE-1008	503-108
TRX500FE Fourtrax Foreman 4x4 ES	05-07	VE-1008	503-108
TRX500FGA Fourman Rubicon	04-05	VE-1008	503-108
TRX500FGA Fourman Rubicon GP	06-07	VE-1008	503-108
TRX500FM Fourtrax Foreman 4x4	05-06	VE-1008	503-108
TRX500TM Fourtrax Foreman	05-06	VE-1008	503-108
TRX650FA Rincon	03-05	VE-1005	503-105
TRX650FA Fourtrax Rincon	04-07	VE-1005	503-105
TRX650FGA Fourtrax Rincon Gpscape	04-05	VE-1005	503-105

## Honda Dual Sport & Offroad

Model	Year	Vesrah Ref.	Order No.
XL75	77-79	VE-1002	503-102
XR75	77-78	VE-1002	503-102
CRF80F	04-08	VE-1031	503-131
XL80S	80-85	VE-1002	503-102
XR80	79-84	VE-1002	503-102
XR80R	85-88	VE-1002	503-102
XR80R	90-91	VE-1002	503-102
XR80R	93-03	VE-1002	503-131
CT90 Trail 90	66-68	VE-1002	503-102
CT90K1-K6 Trail 90	69-75	VE-1002	503-102
CT90 Trail 90	76-79	VE-1002	503-102
CRF100F	03-08	VE-1031	503-131
SL100/K1/K2/K3 Motosport 100	70-73	VE-1003	503-103
XL100/K1	74-75	VE-1003	503-103
XL100	76-78	VE-1003	503-103
XL100S	79-85	VE-1002	503-102
XR100	81-84	VE-1002	503-102
XR100R	85-91	VE-1002	503-102
XR100R	92-03	VE-1031	503-131
CT125 Trail 125	1977	VE-1003	503-103
SL125/K1/K2 Motor Sport	71-73	VE-1003	503-103
TL125K1/K2 Trials	74-75	VE-1003	503-103
TL125S Trials	1976	VE-1003	503-103
XL125/K1	74-75	VE-1003	503-103
XL125	76-78	VE-1003	503-103
XL125S	79-82	VE-1003	503-103
XL125S	84-85	VE-1003	503-103
CRF150F	03-08	VE-1003	503-103
XL175/K1/K2	73-75	VE-1006	503-106
XL175	76-78	VE-1006	503-106
XL185S	79-83	VE-1003	503-103
XR185	1979	VE-1003	503-103
TLR200 Reflex	86-87	VE-1003	503-103
TR200 Fat Cat	86-87	VE-1003	503-103
XL200R	83-84	VE-1003	503-103
XR200 (dual shock)	80-84	VE-1003	503-103
XR200R Pro-Link	81-83	VE-1003	503-103
XR200R	84-85	VE-1031	503-131
XR200R	86-88	VE-1003	503-103
XR200R	90-91	VE-1003	503-103
XR200R	93-02	VE-1003	503-103
CRF230F	03-08	VE-1003	503-103
CRF250R	04-07	VE-1005	503-105
CRF250X	04-07	VE-1005	503-105
NX250	88-90	VE-1005	503-105
TL250 Trials	1976	VE-1003	503-103
XL250/K1/K2 Motor Sport	73-75	VE-1006	503-106
XL250 Motor Sport	1976	VE-1006	503-106
XL250R	82-83	VE-1003	503-103
XL250R	84-87	VE-1031	503-131
XR250L	91-96	VE-1031	503-131
XR250R	81-82	VE-1031	503-131
XR250R	84-04	VE-1031	503-131
SL350/K1/K2 Motor Sport	70-72	VE-1006	503-106
XL350/K1	74-75	VE-1012	503-112
XL350	76-78	VE-1012	503-112
XL350R	84-85	VE-1003	503-103
XR350R	83-84	VE-1003	503-103
XR400R	96-04	VE-1003	503-103
XL500S	79-81	VE-1003	503-103
XR500	79-80	VE-1003	503-103
XR500R	81-84	VE-1003	503-103
XL600R	83-87	VE-1003	503-103
XL600V Transalp	89-90	VE-1008	503-108
XR600R	85-00	VE-1003	503-103
XR650L Dual Sport	93-08	VE-1003	503-103
XR650R	00-07	VE-1003	503-103

## Kawasaki Street

Model	Year	Vesrah Ref.	Order No.
BN125A4/A5 Eliminator 125	01-02	VE-4002	503-402
BN125A7/A8 Eliminator 125	04-05	VE-4002	503-402
BN125A6F Eliminator 125	2006	VE-4002	503-402
KZ200A1/A2	78-79	VE-4002	503-402
EL250B2/B3 Eliminator	88-89	VE-4002	503-402
EL250E/AE2/E3/E4 250HS Eliminator	91-94	VE-4002	503-402
EX250E1/E2 Ninja 250R	86-87	VE-4002	503-402
EX250F2/F3/F4 Ninja 250R	88-90	VE-4002	503-402
EX250F6-F19 Ninja 250R	92-05	VE-4002	503-402
EX250F6F Ninja 250R	2006	VE-4002	503-402
KZ250D1/D2 LTD & CSR	80-81	VE-4002	503-402
KZ250L1 CSR	1982	VE-4002	503-402
KZ250W1 LTD Belt	1983	VE-4002	503-402
EX305B1 GPz Belt	1983	VE-4002	503-402
KZ305A1/A2 CSR	81-82	VE-4002	503-402
KZ305B1 CSR Belt	1982	VE-4002	503-402
KZ305B2/B3 LTD Belt	87-88	VE-4002	503-402
KZ400A1/A2	77-78	VE-4006	503-406
KZ400B1/B2	77-78	VE-4006	503-406
KZ400C1	1978	VE-4006	503-406
KZ400/D/D3/D4	74-77	VE-4006	503-406
KZ400H1 LTD	1979	VE-4006	503-406
KZ400S/S2/S3 Special	75-77	VE-4006	503-406
S3/S3A-400/KH400A	74-77	VE-4003	503-403
KZ440A1/A2/A3/A4 LTD	80-83	VE-4006	503-406
KZ440B1/B2	80-81	VE-4006	503-406
KZ440D1-D5 LTD Belt	80-83	VE-4006	503-406
EN450A1-A6 LTD 454	85-90	VE-4004	503-404
EN500A1-A7 Vulcan 500	90-96	VE-4004	503-404
EN500C1-C10 Vulcan 500 LTD	96-05	VE-4004	503-404
EN500C6F/C7F Vulcan 500 LTD	06 -07	VE-4004	503-404
EX500A1-A7	87-93	VE-4004	503-404
EX500D1/D2/D3 Ninja 500	94-96	VE-4004	503-404
EX500D4-D12 Ninja 500R	97-05	VE-4004	503-404
EX500D6F/D7F/D8F Ninja 500R	06-08	VE-4004	503-404
H1/A/B/C Mach III (2 stroke) Triple	69-72	VE-4003	503-403
H1D/E/F-500 (2 stroke) Triple	73-75	VE-4003	503-403
KH500A8 (2 stroke) Triple	1976	VE-4003	503-403
KZ550A1/A2/A3/A4	80-83	VE-4002	503-402
KZ550C1/C2/C3/C4 LTD	80-83	VE-4002	503-402
KZ550D1 GPz	1981	VE-4002	503-402
KZ550F1 Spectre	1983	VE-4002	503-402
KZ550F2 LTD	1984	VE-4002	503-402
KZ550H1/H2 GPz	82-83	VE-4002	503-402
KZ550M1 LTD Shaft	1983	VE-4002	503-402
ZR550B1/B2	91-92	VE-4002	503-402
ZX550A1/A2 GPz	84-85	VE-4002	503-402
KL600A1 KLR600	1984	VE-4013	503-413
KL600B1/B2 KLR600	85-86	VE-4013	503-413
ZL600A1/A2 Eliminator	86-87	VE-4002	503-402
ZL600B2/B3 Eliminator 600	96-97	VE-4002	503-402
ZX600A1/A2/A3 Ninja 600R	85-87	VE-4002	503-402
ZX600B1 Ninja 600RX	1987	VE-4002	503-402
ZX600C1-C10 Ninja 600R	88-97	VE-4002	503-402
ZX600D1-D4 Ninja ZX-6	90-93	VE-4014	_____
ZX600E1-E10 Ninja ZX-6	93-02	VE-4014	_____
ZX600E11/E12 ZZR600	03-04	VE-4014	_____
ZX600F1/F2/F3 Ninja ZX-6R	95-97	VE-4014	_____
ZX600G1/G2 Ninja ZX-6R	98-99	VE-4014	_____
ZX600J1/J2/J3 Ninja ZX-6R	00-02	VE-4014	_____
ZX600J4 ZZR600	2005	VE-4014	_____
ZX600J6F ZZR600	2006	VE-4014	_____
ZX600K1 Ninja ZX-6RR	2003	VE-4014	_____
ZX600M1 Ninja ZX-6RR	2004	VE-4014	_____
ZX600N1 Ninja ZX-6RR	2005	VE-4014	_____
ZX600N6F Ninja ZX-6RR	2006	VE-4014	_____

## Kawasaki Street

Model	Year	Vesrah Ref.	Order No.
ZX636B1/B2 Ninja ZX-6R	03-04	VE-4001	_____
ZX636C1/C6F ZX-6R	05-06	VE-4001	_____
EJ650A2/A3 W650	00-01	VE-4004	503-404
EX650A6F Ninja 650R	2006	VE-4014	_____
KL650A1-A19 KLR650	87-05	VE-4013	503-413
KL650A6F KLR650	2006	VE-4013	503-413
KL650B2/B3 Tengai KLR650	90-91	VE-4013	503-413
KZ650B1/B2/B2A/B3	77-79	VE-4002	503-402
KZ650C1/C2/C3 Custom	77-79	VE-4002	503-402
KZ650D1/D1A/D2 SR	78-79	VE-4002	503-402
KZ650E1 LTD	1980	VE-4002	503-402
KZ650F1	1980	VE-4002	503-402
KZ650H1/H2/H3 CSR	81-83	VE-4002	503-402
KZ700A1	1984	VE-4002	503-402
ZN700A1/A2 LTD Shaft	1984	VE-4002	503-402
H2/H2A/H2B/H2C-750 triple	72-75	VE-4003	503-403
KZ750B1/B2/B3/B4 (2 cyl.)	76-79	VE-4002	503-402
KZ750E1/E2/E3	80-82	VE-4002	503-402
KZ750F1 LTD Shaft	1983	VE-4002	503-402
KZ750G1 LTD (2 cyl.)	1980	VE-4004	503-404
KZ750H1/H2/H3/H4 LTD	80-83	VE-4002	503-402
KZ750K1/K2 LTD Belt (2 cyl.)	83-84	VE-4004	503-404
KZ750L3	1983	VE-4002	503-402
KZ750M1 CSR (2 cyl.)	1982	VE-4004	503-404
KZ750N1/N2 Spectre	82-83	VE-4002	503-402
KZ750R1 GPz	1982	VE-4002	503-402
ZR750C1/C2/C3 Zephyr	91-93	VE-4002	503-402
ZR750F2 ZR-7	2000	VE-4002	503-402
ZR750H1/H2/H3 ZR-7S	01-03	VE-4002	503-402
ZX750A1/A2/A3 GPz	83-85	VE-4002	503-402
ZX750E1/E2 GPz Turbo	84-85	VE-4002	503-402
ZX750F1/F2/F3/F4 Ninja 750R	87-90	VE-4005	503-405
ZX750H1/H2 Ninja ZX-7	89-90	VE-4005	503-405
ZX750J1/J2 Ninja ZX-7	91-92	VE-4016	_____
ZX750K1/K2 Ninja ZX-7R	91-92	VE-4016	_____
ZX750L1/L2/L3 Ninja ZX-7	93-95	VE-4016	_____
ZX750M1/M2 Ninja ZX-7R	93-94	VE-4016	_____
ZX750N1/N2 Ninja ZX-7RR	96-97	VE-4016	_____
ZX750P1-P8 Ninja ZX-7R	96-03	VE-4016	_____
Z1/Z1A/Z1B-900	73-75	VE-4005	503-405
KZ900A4/A5	76-77	VE-4005	503-405
KZ900B1 LTD	1976	VE-4005	503-405
ZL900A1/A2 Eliminator	85-86	VE-4004	503-404
ZX900A1/A2/A3 Ninja 900R	84-86	VE-4004	503-404
ZX900B1/B2/B3/B4 Ninja ZX-9R	94-97	VE-4014	_____
ZX900C1/C2 Ninja ZX-9R	98-99	VE-4014	_____
ZX900E1/E2 Ninja ZX-9R	00-01	VE-4004	503-404
ZX900F1/F2 Ninja ZX-9R	02-03	VE-4004	503-404
KZ1000A1/A2	77-78	VE-4005	503-405
KZ1000A3/A3A/A4 MKII	79-80	VE-4005	503-405
KZ1000B1/B2/B3/B4 LTD	77-80	VE-4005	503-405
KZ1000C1-C4 Police	78-81	VE-4005	503-405
KZ1000D1 Z1R	1978	VE-4005	503-405
KZ1000D3 Z1R	1980	VE-4005	503-405
KZ1000E1/E2 Shaft ST	79-80	VE-4005	503-405
KZ1000G1 LTD Classic	1980	VE-4005	503-405
KZ1000J1/J2/J3	81-83	VE-4005	503-405
KZ1000K1/K2 LTD	81-82	VE-4005	503-405
KZ1000M1/M2 CSR	81-82	VE-4005	503-405
KZ1000P1-P21 Police	82-02	VE-4005	503-405
KZ1000P24 Police	2005	VE-4005	503-405
KZ1000R1/R2 Replica	82-83	VE-4005	503-405

# Exhaust Pipe Gaskets

## Kawasaki Street

Model	Year	Vesrah Ref.	Order No.
ZG1000A1-A20 Concours	86-05	VE-4004	503-404
ZG1000A6F Concours	2006	VE-4004	503-404
ZL1000A1 Eliminator	1987	VE-4004	503-404
ZR1000A1/A2/A3 Z1000	03-05	VE-4004	503-404
ZX1000A1/A2 Ninja 1000R	86-87	VE-4004	503-404
ZX1000B1/B2/B3 Ninja ZX-10	88-90	VE-4004	503-404
ZX1000C1/C2 Ninja ZX-10R	04-05	VE-4016	————
KZ1100A1/A2/A3 Shaft	81-83	VE-4005	503-405
KZ1100B1/B2 GPz	81-82	VE-4005	503-405
KZ1100D1/D2 Spectre	82-83	VE-4005	503-405
KZ1100L1 LTD Shaft	1983	VE-4005	503-405
ZN1100B1/B2 LTD Shaft	84-85	VE-4005	503-405
ZR1100C3/C4 ZRX1100	99-00	VE-4004	503-404
ZX1100A1/A2 GPz	83-84	VE-4005	503-405
ZX1100C1-C4 Ninja ZX-11	90-93	VE-4004	503-404
ZX1100D1-D9 Ninja ZX-11	93-01	VE-4004	503-404
ZX1100E1/E2/E3 GPz	95-97	VE-4004	503-404
ZX1100F1 GPZ (ABS)	1996	VE-4004	503-404
ZG1200A/B Voyager XII	86-03	VE-4005	503-405
ZR1200A1-A5 ZRX1200	01-05	VE-4004	503-404
ZX1200A1/A2 Ninja ZX-12R	00-01	VE-4004	503-404
ZX1200B1-B4 Ninja ZX-12R	02-05	VE-4004	503-404
ZX1200C1-C4 ZZR1200	02-05	VE-4004	503-404
KZ1300A1/A2/A3/A4	79-82	VE-4002	503-402
KZ1300B2 Tourer	1980	VE-4002	503-402
ZN1300A1-A6 Voyager	83-88	VE-4002	503-402

## Kawasaki ATV

KSF80A1/A2/A3/A6F KFX80	03-06	VE-3026	503-326
KLT160A1	1985	VE-4002	503-402
KLF185A1-A4 Bayou	85-88	VE-4002	503-402
KLT185A1/A2 Bayou	86-87	VE-4002	503-402
KLT200A1-A4	81-83	VE-4002	503-402
KLT200B1	1983	VE-4002	503-402
KLT200C1/C2	83-84	VE-4002	503-402
KLF220A1-A15 Bayou 220	85-02	VE-4002	503-402
KLF250A1/A2/A3 Bayou 250	03-05	VE-4002	503-402
KLF250A6F Bayou 250	2006	VE-4002	503-402
KLT250A1/A2	82-83	VE-4002	503-402
KLT250C1/C2/C3 Prairie	83-85	VE-4002	503-402
KLT250P1 Police	1984	VE-4002	503-402
KSF250A1-A17 Mojave	87-03	VE-4012	503-412
KSF250A18 KFX250 Mojave	2004	VE-4012	503-412
KXF250A1/A2 Tecate 4	87-88	VE-4008	503-408
KXT250A1/A2 Tecate 3	84-85	VE-4008	503-408
KXT250B1/B2 Tecate 3	86-87	VE-4008	503-408
KEF300A1-A6 Lakota 300	95-00	VE-4002	503-402
KEF300B1/B2/B3 Lakota Sport	01-03	VE-4002	503-402
KLF300A1/A2 Bayou 300	86-87	VE-4002	503-402
KLF300B1-B17 Bayou 300	88-04	VE-4002	503-402
KLF300C1-C16 Bayou 4x4	89-04	VE-4002	503-402
KVF300A1-A4 Prairie 300 4x4	99-02	VE-4002	503-402
KVF300B1/B2/B3/B4 Prairie 300	99-02	VE-4002	503-402
KVF360A1/A2/A3 /A6F Prairie 360 4x4	03-06	VE-4011	————
KVF360B1/B2/B3/B6F Prairie 360	03-06	VE-4011	————
KVF360C1 360 4x4 Advantage Classic	2003	VE-4011	————
KVF360C2/C3 360 4x4 Hardwoods	04-05	VE-4011	————
KLF400B1-B7 Bayou 400 4x4	93-99	VE-4002	503-402
KVF400A1/A2 Prairie 4x4	97-98	VE-4002	503-402
KVF400B1 Prairie 400	1998	VE-4002	503-402
KVF400C1-C4 Prairie 400 4x4	99-02	VE-4002	503-402
KVF400D1/D2/D3/D4 Prairie 400	99-02	VE-4002	503-402
KVF650A1/A2 Prairie 650	02-03	VE-4010	————
KVF650B1/B2 Prairie 650	02-03	VE-4010	————
KVF650D1 Brute Force	2005	VE-4010	————

## Kawasaki Dual Sport & Offroad

Model	Year	Vesrah Ref.	Order No.
MT1/C	71-75	VE-4002	503-402
KV75A5-A9	76-80	VE-4002	503-402
KD80A1/A2	75-76	VE-4002	503-402
KD80M1-M8	80-87	VE-4002	503-402
KD100M1/M2/M3/M4	76-79	VE-4002	503-402
KM100A1-A7	76-81	VE-4002	503-402
KD125A2-A5	76-79	VE-4003	503-403
KE125A3-A10	76-83	VE-4003	503-403
KLX125A1/A2/A3/A6F	03-06	VE-3022	503-322
KLX125B1/B2/B3/B6F KLX125F	03-06	VE-3022	503-322
KX125G1/H1/H2	89-91	VE-4004	503-404
KE175D2/D3/D4/D5	80-83	VE-4003	503-403
KDX200E1-E6	89-94	VE-4022	————
KDX200H1-H11/H6F	95-06	VE-4022	————
KDX220A4-A12	97-05	VE-4022	————
KDX250B2/B3/B4	82-84	VE-4008	503-408
KDX250D1/D2/D3/D4	91-94	VE-4008	503-408
KL250A1-A4	78-81	VE-4002	503-402
KL250C1/C2	82-83	VE-4002	503-402
KL250D2-D22 KLR250	85-05	VE-4012	503-412
KLX250A1/A2	79-80	VE-4002	503-402
KX250B1	1982	VE-4008	503-408
KX250D1/D2	85-86	VE-4008	503-408
KX250F1/G1/H1/H2	88-91	VE-4008	503-408
KX250J1/J2/K1	92-94	VE-4008	503-408
KX250N1/N2/T6F KX250F	04-06	VE-4016	————
KLX300A2-A10 KLX300R	97-05	VE-4001	————
KLX300A6F KLX300R	2006	VE-4001	————
KX500B2	1986	VE-4004	503-404
KX500C1	1987	VE-4004	503-404
KX500D1	1988	VE-4008	503-408
KX500E1-E16	89-04	VE-4008	503-408
KL600A1 KLR600	1984	VE-4013	503-413
KL600B1/B2 KLR600	85-86	VE-4013	503-413
KL650A1-A19 KLR650	87-05	VE-4013	503-413
KL650A6F KLR650	2006	VE-4013	503-413
KL650B2/B3 Tengai KLR650	90-91	VE-4013	503-413

## Suzuki Street

GN125Z/D	82-83	VE-3002	503-302
GN125EM	1991	VE-3002	503-302
GN125EN/EP/ER/ES/ET/EV	92-97	VE-3022	503-322
DR250SL/SM/SN Dual Sport	90-92	VE-3022	503-322
DR250SEP/SER/SES Dual Sport	93-95	VE-3023	503-323
GN250Z/D	82-83	VE-3001	503-301
GN250F	1985	VE-3001	503-301
GN250J	1988	VE-3001	503-301
GS300LZ /LD	1982	VE-3002	503-302
GS300LF	1985	VE-3002	503-302
DR350SL/SM/SN/SP Dual Sport	90-93	VE-3022	503-322
DR350SER/S/TV/W/X Dual Sport	94-99	VE-3023	503-323
GN400T/XT/XX/TX/TZ	80-82	VE-3003	503-303
GN400T/XT/XX/TX/TZ	80-82	VE-3003	503-303
GS400B/XB/C/XC	77-78	VE-3003	503-303
GSF400M/N/P Bandit	91-93	VE-3026	503-326
GS425N/EN/LN	1979	VE-3003	503-303
GS450ET/EX/EZ/ED	80-83	VE-3003	503-303
GS450GAZ/GAD Automatic	82-83	VE-3003	503-303
GS450GAF Automatic	1985	VE-3003	503-303
GS450LT/LX/LZ/LD	80-83	VE-3003	503-303
GS450LF/LG/LH/LJ	85-88	VE-3003	503-303
GS450ST/SX	80-81	VE-3003	503-303

## Suzuki Street

Model	Year	Vesrah Ref.	Order No.
GS450TX/TZ/TXZ/TXD	81-83	VE-3003	503-303
GS500EK/L/M/N/P/R/S/T	89-96	VE-3003	503-303
GS500EV/EW/EX/EY/K1/K2	97-02	VE-3003	503-303
GS500FK3/FK4/FK5	03-05	VE-3003	503-303
GS550B/C/EC/N/EN/ET	77-80	VE-3001	503-301
GS550ED/ESD/ES3 (16 valve)	82-83	VE-3002	503-302
GS550ESE/EF/ESF/ESG (16 valve)	84-86	VE-3002	503-302
GS550LN/LT/LX/LZ	79-82	VE-3001	503-301
GS550LD (16 valve)	1983	VE-3002	503-302
GS550LF/LG (16 valve)	85-86	VE-3002	503-302
GS550MZ	1982	VE-3001	503-301
GS550TX	1982	VE-3002	503-301
GSF600ST/SV/SW/SX Bandit	96-99	VE-3022	503-322
GSF600SY/SK1/SK2/SK3 Bandit	00-03	VE-3022	503-322
GSX600FJ/FK/FL/FM Katana	88-91	VE-3022	503-322
GSX600FN-FK5 Katana	92-05	VE-3022	503-322
GSX-R600WN/WP	92-93	VE-3024	503-324
GSX-R600V/W/X/Y	97-00	VE-3005	503-305
GSX-R600K1/K2/K3/K4/K5	01-05	VE-3005	503-305
RF600RR/RS/RT	94-96	VE-3024	503-324
DR650SL/SM/SN/SP Dual Sport	90-93	VE-3003	503-303
DR650SER/SES Dual Sport	94-95	VE-3003	503-303
DR650SET/SEV/SEW/SEX/SEY	96-00	VE-3031	503-303
DR650SEK1/SEK2/SEK3 Dual Sport	01-03	VE-3031	503-303
DR650SEK4/SEK5 Dual Sport	04-05	VE-3031	503-303
GR650D/XD Tempter	1983	VE-3003	503-303
GS650EX/EZ	81-82	VE-3002	503-302
GS650GX/GZ/GD	81-83	VE-3002	503-302
GS650GLX/GLZ/GLD	81-83	VE-3002	503-302
GS650MD Katana	1983	VE-3002	503-302
LS650FG/FH Savage	86-87	VE-3019	503-319
LS650PG/PH/PJ Savage	86-88	VE-3019	503-319
LS650PS-PY Savage	95-00	VE-3019	503-319
LS650PK1-PK4 Savage	01-04	VE-3019	503-319
SV650X/Y/K1/K2/K3/K4/K5	99-05	VE-3031	503-303
SV650SX/SY	99-00	VE-3031	503-303
SV650SK1/SK2/SK3/SK4/SK5	01-05	VE-3031	503-303
XN85D Turbo	1983	VE-3002	503-302
GS700EF/ESF	1985	VE-3002	503-302
GS750B/C/EC/N/EN	77-79	VE-3003	503-303
GS750ET/EX/EZ	80-82	VE-3003	503-303
GS750ED/ESD	1983	VE-3002	503-302
GS750LN	1979	VE-3003	503-303
GS750LT/LX	80-81	VE-3003	503-303
GS750TZ/TD	82-83	VE-3003	503-303
GS750SD Katana	1983	VE-3003	503-303
GSX750FK-FY Katana	89-00	VE-3022	503-322
GSX750FK1-FK5 Katana	01-05	VE-3022	503-322
GSX-R750G/H	86-87	VE-3022	503-322
GSX-R750RG	1986	VE-3022	503-322
GSX-R750J/K/L /M/N	88-92	VE-3022	503-322
GSX-R750WP/WR/WS	93-95	VE-3024	503-324
GSX-R750TV/W/X/Y	96-00	VE-3025	503-325
GSX-R750K1/K2/K3/K4/K5	01-05	VE-3025	503-325
GS850GN/GT/GX/GZ/GD	79-83	VE-3003	503-303
GS850GLT/GLX/GLZ/GLD	80-83	VE-3003	503-303
RF900RR/RS/RT/RV	94-97	VE-3024	503-324
RF900RZS	1995	VE-3024	503-324
DL1000K2/K3/K4/K5 V-Storm	02-05	VE-3036	503-303

## Suzuki Street

Model	Year	Vesrah Ref.	Order No.
GS1000C/EC/N/EN/ET	78-80	VE-3003	503-303
GS1000GT/GLT/GX/GLX	80-81	VE-3003	503-303
GS1000LN	1979	VE-3003	503-303
GS1000SN/ST	79-80	VE-3003	503-303
GS1000SZ Katana	1982	VE-3003	503-303
GSX-R1000K1/K2/K3 /K4/K5	01-05	VE-3025	503-325
TL1000RW/RX/RV/RK1/RK2/RK3	98-03	VE-3036	503-303
TL1000SV/SW/SX/SY/SK1	97-01	VE-3036	503-303
GS1100ET/EX/EZ	80-82	VE-3003	503-303
GS1100ED/ESD	1983	VE-3003	503-303
GS1100GZ/GLZ/GD/GLD	82-83	VE-3003	503-303
GS1100GKZ/GK2/GKD/GKE	82-84	VE-3003	503-303
GS1100LT	1980	VE-3003	503-303
GS1100SD Katana	1983	VE-3003	503-303
GSX1100FJ/K/L/M/N/P Katana	88-93	VE-3022	503-322
GSX1100GM Shaft	1991	VE-3023	503-323
GSX1100GN/GP Shaft	92-93	VE-3022	503-322
GSX-R1100G/H/J	86-88	VE-3022	503-322
GSX-R1100K/L/M/N	89-92	VE-3023	503-323
GSX-R1100WP/R/S/T/V/W	93-98	VE-3025	503-325
GS1150ES3/ESE/EF/ESF/ESF	83-85	VE-3003	503-303
GS1150EF2/EG/ESG	85-86	VE-3003	503-303
GSF1200SAV Bandit	1997	VE-3022	503-322
GSF1200SV/SW/SX/SY Bandit	97-00	VE-3022	503-322
GSF1200SK1/SK2/SK3 Bandit	01-03	VE-3022	503-322
GSF1200SK4/SK5 Bandit	04-05	VE-3022	503-322
GSX1300RX/RV Hayabusa	99-00	VE-3031	503-303
GSX1300RK1-RK5 Hayabusa	01-05	VE-3031	503-303
GV1400GCG/GCH Cavalacade LX	86-87	VE-3004	503-304
GV1400GDG/GDH Cavalacade LX	86-87	VE-3004	503-304
GV1400GDJ/GDK Cavalacade LX	88-89	VE-3004	503-304
GV1400GTG/GTH Cavalacade	86-87	VE-3004	503-304
VS1400GLPL/M/N/P/R Intruder	90-94	VE-3019	503-319
VS1400GLPS/T/V/W Intruder	95-98	VE-3019	503-319
VS1400GLPX/Y/K1/K2/K3/K4	99-04	VE-3019	503-319
VS1400K5 S83Boulevard	2005	VE-3002	503-319

## Suzuki ATV

Model	Year	Vesrah Ref.	Order No.
LT80S/T/M/W/Y/K1-K4 Quadrunner 80	95-04	VE-3026	503-326
ALT125D/E/F/G Quadrunner	83-86	VE-3002	503-302
LT125D/E/F/G/H Quadrunner	83-87	VE-3002	503-302
ALT185F Quadrunner	1985	VE-3002	503-302
LT185E/F/G/H Quadrunner	84-87	VE-3002	503-302
LT230EH/EJ/EK/EL Quadrunner	87-90	VE-3004	503-304
LT230EM/EN/EP Quadrunner	91-93	VE-3004	503-304
LT230GEF/GEG Quadrunner	85-86	VE-3004	503-304
LT230SF/SG/SH/SJ Quadsport	85-88	VE-3004	503-304
LT-F230G/H	86-87	VE-3004	503-304
LT250SK/SL Quadsport	89-90	VE-3004	503-304
LT-Z250K4/K5 Quadsport	04-05	VE-3028	503-328
LT-4WDH/WDJ/WDK 4x4	87-89	VE-3004	503-304
LT-4WDL/M/N/P/R/S/T 4x4	90-96	VE-3004	503-304
LT-300EH/EJ/EK Quadrunner	87-89	VE-3004	503-304
LT-F300FX/FY King Quad	99-00	VE-3028	503-328
LT-F300FK1/FK2 King Quad	01-02	VE-3028	503-328
LT-F4WDXM/N/P/R King Quad	91-94	VE-3004	503-304
LT-F4WDXS/T/V/W King Quad	95-98	VE-3004	503-304
LT-F4WDV/WDW	97-98	VE-3004	503-304
LT-A400FK2/FK3 Eiger Auto 4WD	02-03	VE-3004	503-304
LT-A400FK4/FK5 Eiger Auto 4WD	04-05	VE-3004	503-304
LT-A400FCK3 Eiger Auto 4WD	2003	VE-3004	503-304
LT-A400FCK4 Eiger Auto 4WD	2004	VE-3004	503-304
LT-A400K2/K3/K4 Eiger Auto 2WD	02-04	VE-3022	503-322

# Exhaust Pipe Gaskets

## Suzuki ATV

Model	Year	Vesrah Ref.	Order No.
LT-A500FK2/FK3 Vinson 4WD	02-03	VE-3022	<b>503-322</b>
LT-A500FK4/FCK4 Vinson 4WD	2004	VE-3022	<b>503-322</b>
LT-A500FK5 Vinson 4WD	2005	VE-3022	<b>503-322</b>
LT-F500FK3-FK5 Vinson Manual 4WD	03-05	VE-3022	<b>503-322</b>
LT-F500FW-FK5 Quadrunner	98-05	VE-3022	<b>503-322</b>

## Suzuki Dual Sport & Offroad

RM50C/N/T/X	78-81	VE-3002	<b>503-302</b>
DS80C/N/T/X/Z/D	78-83	VE-3002	<b>503-302</b>
DS80F/G/H/J/K/L/M	85-91	VE-3002	<b>503-302</b>
DS80N/P/R/S/T/V/W/X/Y	92-00	VE-3022	<b>503-322</b>
DS80K1/K2/K3/K4	01-04	VE-3022	<b>503-322</b>
JR80Y/K1/K2/K3/K4	01-04	VE-3022	<b>503-322</b>
DR100D/E/F/G/H/J/K/L	84-90	VE-3022	<b>503-302</b>
SP100D Dual Sport	1983	VE-3022	<b>503-302</b>
DR125Z/D/E	82-84	VE-3022	<b>503-302</b>
DR125G/H/J	86-88	VE-3022	<b>503-302</b>
DR125SER/SES/SET	94-96	VE-3022	<b>503-322</b>
DR-Z125K3/K4/K5	03-05	VE-3022	<b>503-322</b>
DR-Z125LK3/LK4/LK5	03-05	VE-3022	<b>503-322</b>
SP125G/H/J	86-88	VE-3002	<b>503-302</b>
DR200G/H/J	86-88	VE-3004	<b>503-304</b>
DR200SET/V/W/X/Y	96-00	VE-3028	<b>503-328</b>
DR200SK1/SK2/SK3/SK4 Dual Sport	01-04	VE-3028	<b>503-328</b>
DR200SK5 Dual Sport	2005	VE-3028	<b>503-328</b>
SP200G/H/J Dual Sport	86-88	VE-3004	<b>503-304</b>
DR250Z/D	82-83	VE-3001	<b>503-301</b>
DR250F	1985	VE-3001	<b>503-301</b>
DR250L/M/N/P Offroad	90-93	VE-3022	<b>503-322</b>
DR250SL/SM/SN Dual Sport	90-92	VE-3022	<b>503-322</b>
DR250SEP/SER/SES Dual Sport	93-95	VE-3023	<b>503-323</b>
DR-Z250K1/K2/K3/K4/K5	01-05	VE-3022	<b>503-322</b>
RM250N/P/R/S/T/V (washer)	92-97	VE-3030	<b>503-330</b>
RM250XY/K1/K2/K3/K4/K5 (washer)	99-05	VE-3030	<b>503-330</b>
RMX250P/R/S/T/V/W (washer)	93-98	VE-3030	<b>503-330</b>
RM-Z250K4/K5	04-05	VE-4016	————
SP250Z/D Dual Sport	82-83	VE-3001	<b>503-301</b>
SP250F Dual Sport	1985	VE-3001	<b>503-301</b>
DR350SL/SM/SN/SP Dual Sport	90-93	VE-3022	<b>503-322</b>
DR350SER/S/T/V/W/X Dual Sport	94-99	VE-3023	<b>503-323</b>
DR650SL/SM/SN/SP/SER/SES Dual	90-95	VE-3003	<b>503-303</b>
DR650SET/SEV/SEW/SEX/SEY	96-00	VE-3031	————
DR650SEK1-SEK5 Dual Sport	01-05	VE-3031	————

## Yamaha Street

YSR50T/U/W/A/B/D	87-92	VE-2001	<b>503-201</b>
RS100B/C	75-76	VE-2001	<b>503-201</b>
SR185H/J Exciter	81-82	VE-2004	<b>503-204</b>
SR250G/H/J Exciter	80-82	VE-2004	<b>503-204</b>
SR250TH Exciter II	1981	VE-2004	<b>503-204</b>
SRX250T/TC	1987	VE-2012	<b>503-212</b>
XV250U/UC/W/WC Route 66	88-89	VE-2024	<b>503-224</b>
XV250A/AC Route 66	1990	VE-2024	<b>503-224</b>
XV250G/GC-L/LC Route 66	95-99	VE-2024	<b>503-224</b>
XV250P/PC/R/RC Virago 250	02-03	VE-2024	<b>503-224</b>
XV250S/SC/T/TC/V/VK Virago 250	04-06	VE-2024	<b>503-224</b>
FZR400U/SUC-A/SAC	88-90	VE-2026	<b>503-226</b>
XS400J/K Maxim	82-83	VE-2004	<b>503-204</b>
XS400RJ/RK Seca	82-83	VE-2004	<b>503-204</b>
SR500E/F/G/H	78-81	VE-2005	<b>503-205</b>
XT500C/D/E/F/G/H	76-81	VE-2005	<b>503-205</b>
XV500K Virago	1983	VE-2004	<b>503-204</b>
XJ550H/J/K Maxim	81-83	VE-2012	<b>503-212</b>
XJ550RH/RJ/RK Seca	81-83	VE-2012	<b>503-212</b>

## Yamaha Street

Model	Year	Vesrah Ref.	Order No.
XV535A/AC Virago	1990	VE-2004	<b>503-204</b>
XV535E/EC-L/LC Virago	93-99	VE-2004	<b>503-204</b>
XV535SF/SFC-SJ/SJC Virago	94-97	VE-2004	<b>503-204</b>
FJ600L/LC/N/NC	84-85	VE-2012	<b>503-212</b>
FZ600S/SC/T/TC/U/UC	86-88	VE-2012	<b>503-212</b>
FZ600SS/SSC/ST/STC FZ6	04-05	VE-2026	<b>503-226</b>
FZR600W/WC/AC	89-90	VE-2018	<b>503-218</b>
FZR600RA/RAC-RL/RLC	90-99	VE-2026	<b>503-226</b>
SRX600S/SC	1986	VE-2018	<b>503-218</b>
XJ600SD/SDC-SK/SKC Seca II	92-98	VE-2027	<b>503-227</b>
YX600S/SC-A/AC Radian	86-90	VE-2012	<b>503-212</b>
YZF600RG/RGC-RV/RVC	95-06	VE-2026	<b>503-226</b>
YZF-R6L/LC/M/MC/N/NC	99-01	VE-2026	<b>503-226</b>
YZF-R6P/PC/R/RC/S/SC/T/TC	02-05	VE-2026	<b>503-226</b>
YZF-R6SN/SNC Champions LTD ED	2001	VE-2026	<b>503-226</b>
XJ650G/H/J/K Maxim	80-83	VE-2012	<b>503-212</b>
XJ650LH Midnight Maxim	1981	VE-2012	<b>503-212</b>
XJ650LJ/LK Seca Turbo	82-83	VE-2012	<b>503-212</b>
XJ650RJ Seca	1982	VE-2012	<b>503-212</b>
XS1/XS1B/XS2-650	70-72	VE-2005	<b>503-205</b>
TX650/A	73-74	VE-2005	<b>503-205</b>
XS650B/C/D/E/F/2F	75-79	VE-2005	<b>503-205</b>
XS650G/H Special II	80-81	VE-2005	<b>503-205</b>
XS650SE/SF/SG/SH Special	78-81	VE-2005	<b>503-205</b>
XVS650AN/ANC-AT/ATC V-Star Classic	01-05	VE-2004	<b>503-204</b>
XVS650ATR/ATRC V-Star Silverado	2003	VE-2004	<b>503-204</b>
XVS650ATS V-Star Silverado	2004	VE-2004	<b>503-204</b>
XVS650ATT/ATTC V-Star Silverado	2005	VE-2004	<b>503-204</b>
XVS650K/KC-T/TC V-Star Custom	98-05	VE-2004	<b>503-204</b>
FZ700T/TC	1987	VE-2012	<b>503-212</b>
XJ700N/NC/S/SC Maxim	85-86	VE-2012	<b>503-212</b>
XJ700XN/XNC/XS/XSC Maxim X	85-86	VE-2012	<b>503-212</b>
FZ750N/S/SC	85-86	VE-2012	<b>503-212</b>
FZ750U/UC	1988	VE-2012	<b>503-212</b>
FZR750RT/RU	87-88	VE-2012	<b>503-212</b>
XJ750J/K Maxim	82-83	VE-2012	<b>503-212</b>
XJ750MK Midnight Maxim	1983	VE-2012	<b>503-212</b>
XJ750RH/RJ/RK Seca	81-83	VE-2012	<b>503-212</b>
XS750D/2D/E/F	77-79	VE-2004	<b>503-204</b>
XS750SE/SF Special	78-79	VE-2004	<b>503-204</b>
XV750H/J/K Virago	81-83	VE-2011	<b>503-211</b>
XV750MK Midnight Virago	1983	VE-2011	<b>503-211</b>
XV750U/UC-G/GC Virago	88-95	VE-2028	<b>503-228</b>
XV750H1/HC1/J1/JC1 Virago	96-97	VE-2028	<b>503-228</b>
YZF750RF/RFC	1994	VE-2029	<b>503-229</b>
YZF750RH/RHC/RJ/RJC/RK/RKC	96-98	VE-2029	<b>503-229</b>
XS850G/H	80-81	VE-2004	<b>503-204</b>
XS850LG/LH Midnight Special	80-81	VE-2004	<b>503-204</b>
XS850SG/SH Special	80-81	VE-2004	<b>503-204</b>
XJ900RK Seca	1983	VE-2012	<b>503-212</b>
XV920J/K Virago	82-83	VE-2011	<b>503-211</b>
XV920MK Midnight Virago	1983	VE-2011	<b>503-211</b>
XV920RH/RJ	81-82	VE-2011	<b>503-211</b>
FZ1000N/NC/P/PC/R/RC (FZ1)	01-03	VE-2029	<b>503-229</b>
FZ1000S/SC/T/TC (FZ1)	04-05	VE-2029	<b>503-229</b>
FZR1000T/TC-G/GC	87-95	VE-2026	<b>503-226</b>
GTS1000AE/AEC/AF/ AFC	93-94	VE-2026	<b>503-226</b>
XV1000L/LC/N/NC Virago	84-85	VE-2028	<b>503-228</b>
YZF1000RJ/RJC	1997	VE-2026	<b>503-226</b>
YZF1000RK/RKC	1998	VE-2029	<b>503-229</b>
YZF-R1L/LC/M/MC (YZF-R1)	99-00	VE-2029	<b>503-229</b>
YZF-R1N/NC/P/PC (YZF-R1)	01-02	VE-2029	<b>503-229</b>
YZF-R1SN/SNC Champions Limited	2001	VE-2029	<b>503-229</b>
YZF-R1R/RC/S/SC (YZF-R1)	03-04	VE-2029	<b>503-229</b>
YZF-R1T/TC (YZF-R1)	2005	VE-2029	<b>503-229</b>



## Yamaha Street

Model	Year	Vesrah Ref.	Order No.
FJ1100L/LC/N/NC	84-85	VE-2004	503-204
XJ1100J Maxim	1982	VE-2004	503-204
XS1100E/F/G/H	78-81	VE-2004	503-204
XS1100LG/LH Midnight Special	80-81	VE-2004	503-204
XS1100SF/SG/SH Special	79-81	VE-2004	503-204
XV1100S/SC-F/FC Virago	86-94	VE-2011	503-211
XV1100G/GC-L/LC Virago	95-99	VE-2028	503-228
XV1100SH/SHC/SJ/SJC/SK/SKC	96-98	VE-2028	503-228
XVS1100L/LC/M/MC V-Star	99-00	VE-2028	503-228
XVS1100AM/AMC-AS/ASC V-Star Classic	00-04	VE-2028	503-228
XVS1100AT V-Star 1100 Silverado	03-05	VE-2028	503-228
XVS1100AWR/AWRC V-Star 1100 Classic	2003	VE-2028	503-228
XVS1100AWT/AWTC V-Star 1100 Classic		VE-2028	503-228
XVS1100L/LC-S/SC V-Star 1100 Custom	99-04	VE-2028	503-228
FJ1200S/SC/T/TC	86-87	VE-2004	503-204
FJ1200W/WC/A/AC/B/BC/D/DC	89-92	VE-2004	503-204
FJ1200AD/ADC/AE/AEC (ABS)	92-93	VE-2004	503-204
VMX12N/NC/S/SC V-Max	85-86	VE-2005	503-205
VMX12U/UC-V/V/C V-Max	88-06	VE-2005	503-205
XVZ12TDK Venture Royale	1983	VE-2005	503-205
XVZ12TK/L/KC2 Venture	83-84	VE-2005	503-205
XVZ12DL/DN Venture Royale	84-85	VE-2005	503-205
XVZ12DKC2 Venture Royale	1984	VE-2005	503-205
FJR1300R/RC/S/SC/T/TC	03-05	VE-2029	503-229
XVZ13T/TC/U/UC Venture	87-88	VE-2005	503-205
XVZ13DS-DEC Venture Royale	86-93	VE-2005	503-205
XVZ13AH/AHC-AM/AMC	96-00	_____	_____
Royal Star		_____	_____
XVZ13ATH/ATHC-ATM/ATMC	96-00	_____	_____
Royal Star Tour Classic		_____	_____
XVZ13LTJ/LTJC-LTM/LTMC	97-00	_____	_____
Royal Star Tour Deluxe		_____	_____
XVZ13TFL/TFLC-DFM/TFMC	99-00	_____	_____
Royal Star Venture		_____	_____
XVZ13TFSM/TFSMC	2000	_____	_____
Venture MM Limited Edition		_____	_____
XV1600AL/ALC Road Star	1999	_____	_____
XV1600AM/AMC Road Star	2000	_____	_____
XV1600ALM/ALMC	2000	_____	_____
Road Star MM Limited		_____	_____
XV1600ATL/ATLC	1999	_____	_____
Road Star Silverado		_____	_____
XV1600ATM/ATMC	2000	_____	_____
Road Star Silverado		_____	_____
XV17PCP/PCPC Road Star Warrior	2002	VE-2028	503-228

## Yamaha ATV

YFM50S/RT/RV Raptor 50	04-06	VE-2024	503-224
YFM80N/S/T/U Moto-4	85-88	VE-2024	503-224
YFM80D-N Badger	92-01	VE-2024	503-224
YFM80GT Grizzly 80	2005	VE-2024	503-224
YFM80WP/WR/WS Raptor	02-04	VE-2024	503-224
YFM80RT/RV Raptor 80	05-06	VE-2024	503-224
YFA1W Breeze Moto-4	1989	VE-2024	503-224
YFA1B/D/E/F/G/H/J/K Breeze Moto-4	91-98	VE-2024	503-224
YFA1L/MMC/N/NC Breeze Moto-4	99-01	VE-2024	503-224
YFA1P/PC/R/RC/S/SC Breeze	02-04	VE-2024	503-224
YFM125S/GT Grizzly 125	04-05	VE-2024	503-224
YFM125GHT Grizzly 125 Hunter	2005	VE-2024	503-224
YT125G/H/J/K/L/N Tri-Moto	80-85	VE-2002	503-202
YT175J/K Tri-Moto	82-83	VE-2002	503-202
YFM200DXS/DXT/DXU/DXW Moto-4	86-89	VE-2004	503-204

## Yamaha ATV

Model	Year	Vesrah Ref.	Order No.
YFM200N Moto-4	1985	VE-2004	503-204
YFS200U-T Blaster	88-05	VE-2002	503-202
YTM200K/L/N Tri-Moto	83-84	VE-2004	503-204
YTM200N Tri-Moto	1985	VE-2004	503-204
YTM200EK/EL/ERN Tri-Moto	83-85	VE-2004	503-204
YFM225S/T/U Moto-4	86-88	VE-2004	503-204
YTM225DRN/DRS Tri-Moto	85-86	VE-2004	503-204
YTM225DXK/DXL/DXN Tri-Moto	83-85	VE-2004	503-204
YFB250D/E/F/G/H/J Timberwolf	92-97	VE-2004	503-204
YFB250FWF-FWMM/MC Timberwolf 4WD	94-00	VE-2004	503-204
YFB250UH/UJ/UK Timberwolf	96-98	VE-2004	503-204
YFM250W/A/B Moto-4	89-91	VE-2004	503-204
YFM250BT Bruin 250	2005	VE-2004	503-204
YFM250XL/XLC/XM/XMC Beartracker	99-00	VE-2004	503-204
YFM250XN/XP/XR/XS Beartracker 2WD	01-04	VE-2004	503-204
YFM250XHN Beartracker Real Tree	2001	VE-2004	503-204
YFM350AS Bruin 350 Auto 2WD	2004	VE-2025	503-225
YFM350BAT Bruin 2WD	2005	VE-2025	503-225
YFM350ERT/ERU/ERW/ERA Moto-4	87-90	VE-2025	503-225
YFM350ERD/ERE/ERF/ERG Moto-4	92-95	VE-2025	503-225
YFM350FAHS Bruin 350 Auto 4x4	2004	VE-2025	503-225
YFM350FAHT Bruin 4WD Hunter	2005	VE-2025	503-225
YFM350FAS/FAT Bruin 350 Auto 4x4	04-05	VE-2025	503-225
YFM350FHL/FHLC Big Bear 4WD	1999	VE-2025	503-225
YFM350FWT-FWJ Big Bear	87-97	VE-2025	503-225
YFM350FWB/J/FWBK Big Bear	97-98	VE-2025	503-225
YFM350FWBL/FWBLC Big Bear	1999	VE-2025	503-225
YFM350FXG-FXK Wolverine	95-98	VE-2025	503-225
YFM350FXL-FXMC Wolverine	99-00	VE-2025	503-225
YFM350S/RT Raptor 350	04-05	VE-2025	503-225
YFM350RSET Raptor 350SE	2005	VE-2025	503-225
YFM350UH/UJ/UK/UL/ULC Big Bear	96-99	VE-2005	503-225
YFM350XT-Warrior	87-93	VE-2005	503-205
YFM350XF/XFN-XS/XSC Warrior	94-04	VE-2025	503-225
YFP350U Terraplo	1988	VE-2005	503-205
YFZ350T-V Banshee	87-06	VE-2023	503-223
YFZ350LER/LES Banshee Limited Edit.	03-04	VE-2023	503-223
YFZ350RB Banshee Limited Edition	2003	VE-2023	503-223
YFZ350SET Banshee SE	2005	VE-2023	503-223
YFM400FWE-FWK Kodiak	93-98	_____	_____
YFM600FWAK/FWAKC Grizzly	1998	VE-2026	503-226
YFM600FWAL/FWALC Grizzly	1999	VE-2026	503-226
YFM600FWAM/FWAMC Grizzly	2000	VE-2026	503-226
YFM600FWMH/FWHMC Grizzly Realtree	2000	VE-2026	503-226
YFM600FHN Grizzly Realtree Hunter	2001	VE-2026	503-226
YFM600FN Grizzly	2001	VE-2026	503-226
YFM660FHP Grizzly Hunter	2002	VE-2026	503-226
YFM660FP/FPS Grizzly 660	2002	VE-2026	503-226
YFM660RNR/NC/RP/RPB Raptor 660R	01-02	VE-2026	503-226
YFM660RR/RRC/RS/RT Raptor 660R	03-05	VE-2026	503-226
YFM660RLER/RLS Raptor 660R Limit.	03-04	VE-2026	503-226
YFM660RSET Raptor SE	2005	VE-2026	503-226

Note: 503-223 is a muffler gasket, not an exhaust pipe gasket.

## Yamaha Dual Sport & Offroad

YZ50G	1980	VE-2001	503-201
YZ60H/J/K	1980	VE-2001	503-201
DT80H/J/K	81-83	VE-2001	503-201
YZ80E/F/G/H/J	78-82	VE-2002	503-202
TT-R90	99-05	VE-2024	503-224
TT-R125LWM	2000	VE-2027	503-227
TT-R125RM/RMC	2000	VE-2027	503-227
YZ125D/E	77-78	_____	_____
BW200N/S	85-86	VE-2004	503-204
BW200ES/ET/EU	85-88	VE-2004	503-204

# Exhaust Pipe Gaskets

## Yamaha Dual Sport & Offroad

Model	Year	Vesrah Ref.	Order No.
TW200T/TC-T1/T1C Trailway	87-05	VE-2004	503-204
XT200J/K/KC Dual Sport	82-83	VE-2004	503-204
TT225S/T	86-87	VE-2004	503-204
TT-R225L/LC-S/SC	99-04	VE-2004	503-204
XT225D/DC-V/MC Serow	92-06	VE-2004	503-204
TT-R230T/TC/V/MC	05-06	VE-2004	503-204
IT250F/G/H/J/K	79-83	VE-2014	503-214
TT250G/H/J	80-82	VE-2004	503-204
TT-R250M/MC/N/NC/P/PC	00-02	VE-2029	503-229
TT-R250R/RC/S/SC/T/TC/V/MC	03-06	VE-2029	503-229
WR250ZB/ZD/ZE/ZF/ZG/ZH/ZJ	91-97	VE-2014	503-214
WR250FN/FP/FR/FS/FT/FV	01-06	VE-2031	_____
XT250G/H/J/K/KC Dual Sport	80-83	VE-2004	503-204
XT250L/LC Dual Sport	1984	VE-2012	503-212
YZ250WRW/WRA	89-90	VE-2014	503-214
YZ250FN/FP/FR/FS/FT 4-stroke	01-05	VE-2031	_____
YZ250G/H/J	80-82	VE-2014	503-214
YZ250T/U/W/A/B/D/E1/F1	87-94	VE-2014	503-214
TT350S/T Offroad	86-87	VE-2012	503-212
XT350N/NC-B/BC Dual Sport	85-91	VE-2012	503-212
XT350D/DC-M/MC Dual Sport	92-00	VE-2027	503-227
WR400FK/FL/FM	98-00	VE-2032	_____
YZ400FK/FL	98-99	VE-2032	_____
WR426FN/FP	01-02	VE-2032	_____
YZ426FM/FN/FP	00-02	VE-2032	_____
WR450FR/FS/FT/FV	03-06	VE-2032	_____
YZ450FR/FS/FT	03-05	VE-2032	_____
IT465H/J	81-82	VE-2014	503-214
YZ465G/H/J	80-82	VE-2014	503-214
IT490K/L	83-84	VE-2014	503-214
YZ490J/K	82-83	VE-2014	503-214
TT500C/D/E/F/G/H Dual Sport	76-81	VE-2005	503-205
XT500C/D/E/F/G/H Dual Sport	78-81	VE-2005	503-205
XT550J/K Dual Sport	82-83	VE-2018	503-218
TT600K/L/N/S Offroad	83-86	VE-2018	503-218
XT600L/LC-W/C Dual Sport	84-89	VE-2018	503-218
XT600EA/EAC-EE/EEC Dual Sport	90-93	VE-2018	503-218
XT600EF/EFC/EG/EGC Dual Sport	94-95	VE-2026	503-226



## Coolant Recovery System

Prevents loss of coolant due to overheating, works on most off-road water-cooled motorcycles, snowmobiles and ATVs, designed for hot weather and/or high-altitude riding conditions, mounts to frame or behind number plate, includes 8 oz. bottle, hoses, clamps, mounting strap and instructions.

Order No. 950-778





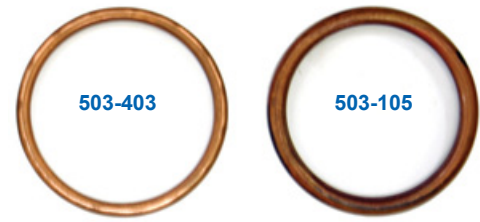

## Sudco Part Number to OEM Cross Reference Exhaust Pipe Gaskets

### Honda

OEM Reference	Dimensions I.D. x O.D. x Thickness	Vesrah Reference	Order No.
18291-KK0-003	30.00 x 37.80 x 4.0mm	VE-1031	503-131
18291-KZ1-670	30.00 x 37.80 x 4.0mm	VE-1031	503-131
18291-MN4-920	34.80 x 43.00 x 4.0mm	VE-1008	503-108
18291-MN5-650	31.50 x 39.80 x 4.0mm	VE-1003	503-103
18291-MM5-860	37.00 x 45.10 x 4.0mm	VE-1005	503-105
18291-MM8-880	44.20 x 52.00 x 4.0mm	VE-1012	503-112
18291-MR5-801	44.20 x 52.00 x 4.0mm	VE-1012	503-112
18291-MV9-000	34.80 x 43.00 x 4.0mm	VE-1008	503-108
18291-028-306	32.00 x 38.00 x 3.5mm	VE-1002	503-102
18291-283-000	44.20 x 52.00 x 4.0mm	VE-1012	503-112
18291-286-306		VE-1006	503-106

### Kawasaki

18067-004	32.70 x 39.00 x 3.0mm	VE-4002	503-402
18067-008		VE-4003	503-403
18067-018	34.80 x 43.00 x 4.1mm	VE-4005	503-405
18067-020	34.5 x 45.0 x 5.0mm	VE-4006	503-406
11009-1253		VE-4008	503-408
11009-1374		VE-4013	503-413
11009-1380		VE-4007	
11009-1840		VE-4004	503-404
11009-1866	32.70 x 39.00 x 3.0mm	VE-4002	503-402
11009-1906	34.80 x 43.00 x 4.1mm	VE-4005	503-405
11009-1949		VE-4008	503-408
11060-1108	50.90 x 60.10 x	VE-4013	503-413
11060-1242	34.5 x 45.0 x 5.0mm	VE-4006	503-406
11060-1488		VE-4007	
11060-1496	39.30 x 45.60 x 2.40mm	VE-4003	503-403
11060-1764	41.50 x 49.40 x 4.1mm	VE-4012	503-412
11061-S058		VE-3026	503-326

### Suzuki

14181-37D00		VE-3001	503-301
14172-02B40		VE-3027	503-327
14181-01D00	38.00 x 46.60 x 5.0mm	VE-3003	503-303
14181-05020	32.00 x 42.00 x 5.0mm	VE-3002	503-302
14181-05010	32.00 x 42.00 x 5.0mm	VE-3002	503-302
14181-11010	38.00 x 46.60 x 5.0mm	VE-3003	503-303
14181-11020	38.00 x 46.60 x 5.0mm	VE-3003	503-303
14181-12010		VE-3004	503-304
14181-17C00	32.00 x 42.00 x 5.0mm	VE-3002	503-302
14181-17E00	28.70 x 42.00 x 2.50mm	VE-3024	503-324
14181-18C00	32.00 x 42 x 5.5mm	VE-3022	503-322
14181-23E00	29.40 x 38.80 x 5.0mm	VE-3026	503-326
14181-42A00		VE-3004	503-304
14181-45C00		VE-3019	503-319
14181-38A00		VE-3019	503-319
14181-40C00	35.20 x 41.75 x 3.00mm	VE-3023	503-323
14181-46E00	33.30 x 42.00 x 5.00mm	VE-3025	503-325
14181-45D00	29.40 x 38.80 x 5.0mm	VE-3026	503-326
14181-42A00	34.20 x 43.20 x 5.0mm	VE-3028	503-328
14172-27C30		VE-3029	503-329
14172-28C30	40.40 x 49.50 x 1.0mm	VE-3030	503-330

## Sudco Part Number to OEM Cross Reference Exhaust Pipe Gaskets

### Yamaha

OEM Reference	Dimensions I.D. x O.D. x Thickness	Vesrah Reference	Order No.
3MT-14613-00-00		VE-2001	503-201
3RV-14623-00-00			
132-14613-00-00			
3PA-14613-10-00		VE-2002	503-202
3PA-14613-00-00			
152-14613-00-00			
4BE-14613-00-00	38.20 x 45.60 x 4.8mm	VE-2004	503-204
4TR-14613-00-00	38.20 x 45.60 x 4.8mm		
341-14613-00-00	38.20 x 45.60 x 4.8mm		
2GV-14613-00	38.20 x 45.60 x 4.8mm		
90430-38054	39.10 x 49.00 x 4.8mm	VE-2005	503-205
4X4-14623-10-00		VE-2010	503-210
4X4-14613-00-00		VE-2010	503-210
4X7-14613-00-00		VE-2011	503-211
4H7-14613-00-00	30.10 x 39.00 x 3.2mm	VE-2012	503-212
3R4-14613-00-00		VE-2014	503-214
5Y1-14613-00-00	32.00 x 40.50 x 3.0mm	VE-2018	503-218
2GU-14613-10-00	56.60 x 80.30 x 5.0mm	VE-2023	503-223
3DM-14613-00-00		VE-2024	503-224
22F-14613-00-00			
3GD-14613-00-00	38.50 x 49.50 x 5.0mm	VE-2025	503-225
3YF-14613-01-00	32.00 x 42.00 x 3.0mm	VE-2026	503-226
4BR-14613-00-00	30.50 x 39.10 x 5.0mm	VE-2027	503-227
3EG-14613-00-00	42.52 x 55.36 x 3.40mm	VE-2028	503-228
4FM-14613-00-00	37.20 x 44.75 x 3.50mm	VE-2029	503-229

Note: 503-223 is a muffler gasket, not an exhaust pipe gasket.



# Valve Cover Gaskets & Cam End Rubber Plugs



619-009



619-018

## Vesrah Valve Cover Gaskets & Cam End Plugs

Sold each. *Made in Japan.*

### Honda Street

Model	Year	Vlv.Cover Gasket	Cam End Rubber Plug
XL75	77-79	619-009	_____
XL80S	80-85	619-009	_____
XL100S	79-85	619-009	_____
CB250 Nighthawk	93-05	619-014	_____
CMX250C Rebel	85-87	619-014	_____
CMX250C	96-97	619-014	_____
CMX250C	99-12	619-014	_____
CMX250C2	99-00	619-014	_____
CMX250CD Rebel	1986	619-014	_____
XL250R Dual Sport	82-83	619-005	_____
XL250S Dual Sport	78-81	619-005	_____
XL350R Dual Sport	84-85	619-023	_____
CB400A Automatic	1978	619-007	_____
CB400T Hawk	80-81	619-007	_____
CB400T1 Hawk	78-79	619-007	_____
CB400TII Hawk	78-79	619-007	_____
CM400A Automatic	79-81	619-007	_____
CM400C Custom	1981	619-007	_____
CM400E	80-81	619-007	_____
CM400T	79-81	619-007	_____
CB450D Super Sport 450	1967	619-035	_____
CB450K0	65-68	619-035	_____
CB450K1-K7 Super Sport 450	68-74	619-035	_____
CB450SC Nighthawk	82-86	619-007	_____
CB450T Hawk	1982	619-007	_____
CL450/K1-K6 Scrambler 450	67-74	619-035	_____
CM450A Automatic	82-83	619-007	_____
CM450C Custom	1982	619-007	_____
CM450E	82-83	619-007	_____
CB500K0/K1/K2 (4cyl.)	71-73	619-006	_____
CB500T (twin)	75-76	619-035	_____
CX500	78-79	619-004	_____
CX500C Custom	79-82	619-004	_____
CX500D Deluxe	79-81	619-004	_____
FT500 Ascot	82-83	619-005	_____
GL500 Silverwing	81-82	619-004	_____
GL500I Interstate	81-82	619-004	_____
VF500C V30 Magna	84-85	619-016	_____
VF500F Interceptor	84-86	619-016	_____
VT500C Shadow	83-86	619-015	_____
VT500FT Ascot	83-84	619-015	_____
XL500S Dual Sport	79-81	619-005	_____
CB550F Super Sport	75-77	619-006	_____
CB550/K1	74-75	619-006	_____
CB550K	76-78	619-006	_____
CBR600F Hurricane	87-90	619-044	_____
CBR600F2 Hurricane	91-94	619-050	_____
CBR600F3 Hurricane	95-98	619-050	_____
CBR600SE	1998	619-050	_____
CBR600SJR Replica	1996	619-050	_____
VT600C Shadow VLX	88-89	619-015	_____
VT600C Shadow VLX	91-97	619-015	_____
VT600C Shadow VLX	99-07	_____	_____

### Honda Street

Model	Year	V.Cover Gasket	Cam End Rubber Plug
VT600CD Deluxe	93-94	619-015	_____
XL600R Dual Sport	83-87	619-024	_____
XL600V Transalp	89-90	619-015	_____
CX650C Custom	1983	619-004	_____
CX650T Turbo	1983	619-004	_____
GL650 Silverwing	1983	619-004	_____
GL650I Silverwing Interstate	1983	619-004	_____
NX650	88-89	619-024	_____
XR650L Dual Sport	93-12	619-024	_____
CB700SC Nighthawk S	84-86	619-018	_____
VFR700F Interceptor	1986	619-041	_____
VFR700F2 Interceptor	86-87	619-041	_____
CB750 Nighthawk	91-03	619-018	_____
CB750A Automatic	76-78	619-003	_____
CB750F Super Sport	75-78	619-003	_____
CB750K/K1/K2/K3/K4/K5	69-75	619-003	_____
CB750K	76-78	619-003	_____
VF750C V45 Magna	1988	619-019	_____
VF750C Magna	94-03	619-047	_____
VF750CD Magna Deluxe	95-96	619-047	_____
VF750C2 Deluxe	97-00	619-047	_____
VFR750F	90-97	619-047	_____
CBR900RR	93-99	619-054	_____
CB1000	94-95	619-043	_____
CBR1000F Hurricane	87-88	619-043	_____
CBR1000F Hurricane	90-91	619-043	_____
CBR1000F Hurricane	93-96	619-043	_____
GL1000 Goldwing	75-79	619-001	_____
GL1000L Goldwing LTD	1976	619-001	_____
VF1000R	85-86	619-019	_____
GL1100 Goldwing	80-83	619-001	_____
GL1100A Golden Aspencade	82-83	619-001	_____
GL1100I Goldwing Interstate	80-83	619-001	_____
ST1100	91-02	619-059	_____
ST1100A (ABS)	92-02	619-059	_____
VF1100C V65 Magna	83-86	619-021	_____
VF1100S V65 Sabre	84-85	619-021	_____
GL1200 Goldwing	1984	619-038	_____
GL1200A Goldwing Aspencade	84-87	619-038	_____
GL1200I Goldwing Interstate	84-87	619-038	_____
GL1200L Goldwing LTD	1985	619-038	_____
GL1200SEi Goldwing SEi	1986	619-038	_____
GL1500 Goldwing	88-90	619-048	_____
GL1500A Goldwing Aspencade	91-00	619-048	_____
GL1500C Valkyrie	97-00	619-048	_____
GL1500C Valkyrie	2003	619-048	_____
GL1500CD Valkyrie	01-03	619-048	_____
GL1500CF Interstate Interstate	99-01	619-048	_____
GL1500CT Valkyrie Tourer	97-00	619-048	_____
GL1500I Goldwing Interstate	91-96	619-048	_____
GL1500SE Goldwing SE	90-00	619-048	_____

# Valve Cover Gaskets & Cam End Rubber Plugs

## Honda ATV

Model	Year	V.Cover Gasket	Cam End Rubber Plug
ATC200X	86-87	619-026	————
TRX200	90-91	619-026	————
TRX200D	91-97	619-026	————
TRX200SX	86-88	619-026	————
ATC250ES	85-87	619-005	————
ATC250SX	85-87	619-005	————
TRX250	85-87	619-005	————
TRX400EX Fourtrax 400EX	99-00	619-056	————
TRX400EX Sporttrax 400EX	01-08	619-056	————
TRX400X	09-12	619-056	————

## Honda Dual Sport & Offroad

XL75	77-79	619-009	————
XR75	77-79	619-009	————
CRF80F	04-12	619-009	————
XL80S	80-85	619-009	————
XR80	79-84	619-009	————
XR80R	85-88	619-009	————
XR80R	90-91	619-009	————
XR80R	93-03	619-009	————
CRF100F	04-09	619-009	————
XL100S	79-85	619-009	————
XR100	81-84	619-009	————
XR100R	85-03	619-009	————
TR200 Fatcat	86-87	619-026	————
XL250R	82-83	619-005	————
XL250S	78-81	619-005	————
XR250R	81-82	619-005	————
XR250R	95-04	619-022	————
XL350R	84-85	619-023	————
XR350R	83-85	619-023	————
XR400R	96-04	619-056	————
XL500S	79-81	619-005	————
XR500	79-80	619-005	————
XR500R	81-82	619-005	————
XR500R	83-84	619-024	————
XL600R Dual Sport	83-87	619-024	————
XL600V Transalp	1989-	619-015	————
XR650R	85-00	619-024	————
NX650	88-89	619-024	————
XR650L Dual Sport	93-12	619-024	————

## Kawasaki Street

KL250D2-D22 KLR250 Dual	85-05	619-615	————
EN450A1-A6 LTD454	85-90	619-616	————
EN500A1-A7 Vulcan 500	90-96	619-616	————
EN500C1-C10 Vulcan LTD	96-05	619-616	————
EN500C6F-C9F	06-09	619-616	————
EX500A1-A7	87-93	619-616	————
EX500D1/D2/D3 Ninja 500	94-96	619-616	————
EX500D4-D12 Ninja 500R	97-05	619-616	————
EX500D6F/D7F/D9F Ninja 500R	06-09	619-616	————
KZ550A1/A2/A3	80-82	619-604	620-991
KZ550A4	1983	619-609	620-991
KZ550C1/C2/C3/C4 LTD	80-83	619-604	620-991
KZ550D1 GPz	1981	619-604	620-991
KZ550F1 Spectre	1983	619-609	620-991
KZ550F2 LTD	1983	619-609	620-991
KZ550H1/H2 GPz	82-83	619-609	620-991
KZ550M1 LTD	1983	619-609	620-991
ZX550A1/A2 GPz	84-85	619-609	620-991
KL600A1/B1/B2 KLR600	84-86	619-617	————
ZL600A1/A2 Eliminator	85-86	619-614	————
ZL600B2/B3 Eliminator 600	96-97	619-614	————
ZX600A1/A2/A3 Ninja 600R	85-87	619-614	————
ZX600B1 Ninja 600RX	1987	619-614	————
ZX600C1-C10 Ninja 600R	88-97	619-614	————

## Kawasaki Street

Model	Year	V.Cover Gasket	Cam End Rubber Plug
KL650A1-A19 KLR650	87-05	619-617	————
KL650A6F-ECF KLR650	06-12	619-617	————
KL650B2/B3 Tengai KLR650	90-91	619-617	————
KZ650B1/B2/B2A	77-78	619-613	620-991
KZ650B3	1979	619-605	620-991
KZ650C1/C2 Custom	77-78	619-613	620-991
KZ650C3 Custom	1979	619-605	620-991
KZ650D1 SR	1978	619-613	620-991
KZ650D2 SR	1979	619-605	620-991
KZ650E1 LTD	1980	619-605	620-991
KZ650F1	1980	619-605	620-991
KZ650H1/H2 CSR	81-82	619-608	620-991
KZ650H3 CSR	1983	619-610	620-991
KZ700A1	1984	619-610	620-991
ZN700A1/A2 LTD	84-85	619-610	620-991
KZ750B1/B2/B3/B4 (2-cyl.)	76-79	619-602	————
KZ750E1/E2/E3	80-82	619-608	620-991
KZ750F1 LTD Shaft	1983	619-610	620-991
KZ750G1 LTD (2-cyl.)	1980	619-602	————
KZ750H1/H2/H3 LTD	80-82	619-608	620-991
KZ750H4 LTD	1983	619-610	620-991
KZ750L3	1983	619-610	620-991
KZ750N1/N2 Spectre	82-83	619-610	620-991
KZ750R1 GPz	1982	619-610	620-991
ZX750A1/A2/A3 GPz	83-85	619-610	620-991
ZX750E1/E2 GPz Turbo	84-85	619-610	620-991
Z1/A/B-900	73-75	619-601	620-990
KZ900A4/A5	76-77	619-601	620-990
KZ900B1 LTD	1976	619-601	620-990
ZL900A1/A2 Eliminator	85-86	619-611	————
ZX900A1/A2/A3 Ninja	84-86	619-611	————
KZ1000A1/A2	77-78	619-601	620-990
KZ1000A3/A3A/A4 MKII	79-80	619-603	620-990
KZ1000B1/B2 LTD	77-78	619-601	620-990
KZ1000B3/B4 LTD	79-80	619-603	620-990
KZ1000C1/C1A Police	1978	619-601	620-990
KZ1000C2-C4 Police	79-81	619-603	620-990
KZ1000D1 Z1R	1978	619-601	620-990
KZ1000D3 Z1R	1980	619-603	620-990
KZ1000E1/E2 Shaft ST	79-80	619-603	620-990
KZ1000G1 LTD Classic	1980	619-603	620-990
KZ1000J1/J2/J3	81-83	619-606	620-992
KZ1000K1/K2 LTD	81-82	619-606	620-992
KZ1000M1/M2 CSR	81-82	619-606	620-992
KZ1000P1-P21 Police	82-02	619-606	620-992
KZ1000R1/R2 Replica	82-83	619-606	620-993
ZX1000B1/B2/B3 Ninja ZX-10	88-90	619-619	————
ZG1000A1-A20 Concours	86-05	619-611	————
ZG1000A6F	2006	619-611	————
ZL1000A1 Eliminator	1987	619-611	————
ZX1000A1/A2 Ninja 1000R	86-87	619-611	————
KZ1100AI/A2/A3 Shaft	81-83	619-606	620-992
KZ1100BI/B2 GPz	81-82	619-606	620-993
KZ1100D1/D2 Spectre	82-83	619-606	620-992
KZ1100L1 LTD Shaft	1983	619-606	620-992
ZN1100BI/B2 LTD	84-85	619-606	620-992
ZX1100AI/A2 GPz	83-84	619-606	620-993
ZX1100C1-C4 Ninja ZX-11	90-93	619-619	————
ZX1100D1-D9 Ninja ZX-11	93-01	619-619	————
ZX1100E1/E2/E3 GPz 1100	95-97	619-619	————
ZX1100F1 GPz 1100 (ABS)	1996	619-619	————
ZG1200A Voyager XII	1986	619-622	————
ZG1200B Voyager XII	87-03	619-622	————
KZ1300A1-A4	79-82	619-607	————
KZ1300B2 Touring	1980	619-607	————
ZN1300A1-A6 Voyager	83-87	619-607	————

# Valve Cover Gaskets & Cam End Rubber Plugs

## Kawasaki ATV

Model	Year	V.Cover Gasket	Cam End Rubber Plug
KSF250A1-A17 Mojave 250	87-03	619-615	_____
KSF250A18 KFX250 Mojave	2004	619-615	_____

## Kawasaki Dual Sport

Model	Year	V.Cover Gasket	Cam End Rubber Plug
KL250D2-D22 KLR250 Dual	85-05	619-615	_____
KL600A1 KLR600	1984	619-617	_____
KL600B1/B2 KLR600	85-86	619-617	_____
KL650A1-A19 KLR650	87-05	619-617	_____
KL650A6F-ECF KLR650	06-12	619-617	_____
KL650B1/B2 Tengai KLR650	90-91	619-617	_____

## Suzuki Street

Model	Year	V.Cover Gasket	Cam End Rubber Plug
GS250TT/TX	80-81	_____	620-981
GS300LZ/LD	82-83	_____	620-981
GS300LF	1985	_____	620-981
GS400B/XB/C/XC	77-78	619-301	620-981
GS425N/EN/LN	1979	619-301	620-981
GS450ET/EX/EZ/ED	80-83	_____	620-981
GS450GAZ/GAD Automatic	82-83	_____	620-981
GS450GAF Automatic	1985	_____	620-981
GS450LT/LX/LZ/LD	80-83	_____	620-981
GS450LF/LG/LH/LJ	85-88	_____	620-981
GS450ST/SX	80-81	_____	620-981
GS450TX/TZ/TXZ/TXD	81-83	_____	620-981
GS500E K-S	89-94	619-327	_____
GS500E T-Y	95-99	619-327	_____
GS500K1-K3	00-03	619-327	_____
GS500F K4-L0	04-10	619-327	_____
GS550B/C/EC/N/EN/ET	77-80	619-304	620-981
GS550LN/LT/LX/LZ	79-82	619-304	620-981
GS550MZ	1982	_____	620-981
GS550TX	1981	619-304	620-981
GSF600ST/SV/SW/SX Bandit	96-99	619-328	_____
GSF600SY/SK1-SK3 Bandit	00-03	619-328	_____
GSX600FJ-FK6 Katana	88-06	619-328	_____
GSX-R600WN/WP	92-93	619-330	_____
RF600RR/RS/RT	94-96	619-331	_____
GR650D/XD Tempter	1983	619-327	_____
GS650EX/EZ	81-82	_____	620-981
GS650GX	1981	_____	620-981
GS650GZ/GD	82-83	_____	620-981
GS650GLX/GLZ	81-82	_____	620-981
GS650GLD	1983	_____	620-981
GS650MD Katana	1983	_____	620-981
XN85 Turbo	1983	_____	620-981
GS700EF/ESF	1985	619-326	_____
GS750B/C/EC/N/EN	77-79	619-302	620-981
GS750ET/EX	80-81	619-305	620-981
GS750EZ	1982	619-307	620-981
GS750ED/ESD	1983	619-326	_____
GS750LN	1979	619-302	620-981
GS750LT/LX	80-81	619-305	620-981
GS750SD Katana	1983	619-320	620-981
GS750TZ/TD	82-83	619-307	620-981
GSX750FK-FV Katana	89-97	619-329	_____
GSX750FW-FK6 Katana	98-06	619-328	_____
GSX-R750RG	1986	619-328	_____
GSX-R750G/H	86-87	619-328	_____
GSX-R750J/K	88-89	619-329	_____
GSX-R750L/M/N	90-92	619-328	_____
GSX-R750WP/WR/WS	93-95	619-330	_____
GS850GN/GT/GX	79-81	619-302	620-981
GS850GZ/GD	82-83	_____	620-981
GS850GLT/GLX	80-81	619-302	620-981
GS850GLZ/GLD	82-83	_____	620-981
RF900RR/RS/RT/RV	94-97	619-331	_____

## Suzuki Street

Model	Year	V.Cover Gasket	Cam End Rubber Plug
RF900RZS	1995	619-331	_____
GS1000C/EC/N/EN/ET	78-80	619-303	620-981
GS1000GT/GLT/GX/GLX	80-81	619-303	620-981
GS1000LN	1979	619-303	620-981
GS1000SN/ST	79-80	619-303	620-981
GS1000SZ Katana	1982	619-305	620-981
GS1100ET/EX	80-81	619-305	620-981
GS1100EZ	1982	619-307	620-981
GS1100ED/ESD	82-83	619-320	620-981
GS1100GZ/GLZ/GD/GLD	82-83	619-306	620-981
GS1100GKZ/GK2/GKD/GKE	82-84	619-306	620-981
GS1100LT	1980	619-305	620-981
GS1100SD Katana	1983	619-320	620-981
GSX1100FJ-FP Katana	88-93	619-329	_____
GSX1100GM/GN/GP Shaft	91-93	619-329	_____
GSX-R1100G/H/J	86-88	619-329	_____
GSX-R1100K/L/M/N	89-92	619-329	_____
GSX-R1100WP-WW	93-98	619-330	_____
GSF1200SV-SK5 Bandit	97-05	619-329	_____
GSF1200SAV Bandit	1997	619-329	_____

## Yamaha Street

Model	Year	V.Cover Gasket	Cam End Rubber Plug
SRX250T/TC	1987	619-209	_____
FZR400U/SUC-A/SAC	88-90	619-215	_____
XS400J/K Maxim	82-83	619-205	620-998
XS400RJ/RK Seca	82-83	619-205	620-998
XJ550H/J/K Maxim	81-83	619-206	_____
XJ550RH/RJ/RK Seca	81-83	619-206	_____
FJ600L/LC/N/NC	84-85	619-206	_____
FZ600S/SC/TT/TC/U/UC	86-88	619-206	_____
FZR600W/WC/AC	89-90	619-215	_____
FZR600RA/RAC-RL/RLC	90-99	619-215	_____
YX600S/SC-A/AC Radian	86-90	619-206	_____
XJ650G/H Maxim	80-81	619-202	620-998
XJ650J/K Maxim	82-83	619-213	_____
XJ650LH Midnight Maxim	1981	619-202	620-998
XJ650LH Midnight Maxim	1981	619-202	620-998
XJ650LJ/LK Seca Turbo	82-83	_____	620-998
XJ650RJ Seca	1982	619-202	620-998
FZ700T/TC	1987	619-211	_____
XJ700N/NC/S/SC Maxim	85-86	619-213	_____
XJ700X Maxim X	85-86	619-211	_____
FZ750N/S/SC	85-86	619-211	_____
FZ750U/UC	1988	619-211	_____
FZR750RT/RU	87-88	619-211	_____
XJ750J/K Maxim	82-83	619-213	_____
XJ750MK Midnight Maxim	1983	619-213	_____
XJ750RH/RJ/RK Seca	82-83	619-213	_____
XS750D/2D/E/F	77-79	619-201	620-998
XS750SE/SF Special	78-79	619-201	620-998
YZF750RF/RFC	1994	619-211	_____
YZF750RH/RHC/RJ/RJC	96-97	619-211	_____
YZF750RK/RKC	1998	619-211	_____
XS850G/H	80-81	619-201	620-998
XS850LG/LH Midnight Special	80-81	619-201	620-998
XS850SG/SH Special	80-81	619-201	620-998
FZR1000T/TC/U/UC	87-88	619-211	_____
FZR1000W/WC-G/GC	89-95	619-211	_____
GTS1000AE/AEC/AF/AFC	93-94	619-211	_____
YZF1000R/RJC	1997	619-211	_____
FJ1100L/LC/N/NC	84-85	619-210	_____
XJ1100J Maxim	1982	619-203	620-998
XS1100E/F/G/H	78-81	619-203	620-998
XS1100LG/LH Midnight Special	80-81	619-203	620-998
XS1100SF/SG/SH Special	79-81	619-203	620-998

# Valve Cover Gaskets & Cam End Rubber Plugs

## Yamaha Street

Model	Year	V.Cover Gasket	Cam End Rubber Plug
FJ1200S/SC/T/TC	86-87	<b>619-210</b>	_____
FJ1200W/WC/A/AC	89-90	<b>619-210</b>	_____
FJ1200B/BC/D/DC	91-92	<b>619-210</b>	_____
FJ1200AD/ADC/AE/AEC(ABS)	92-93	<b>619-210</b>	_____

## Yamaha Dual Sport & Offroad

Model	Year	V.Cover Gasket	Cam End Rubber Plug
XT250L/LC Dual Sport	1984	<b>619-209</b>	_____
TT350S/T	86-87	<b>619-209</b>	_____
XT350N/NC-M/MC Dual Sport	85-00	<b>619-209</b>	_____

## Sudco Part Number to OEM Cross Reference Valve Cover Gaskets

### Honda

OEM Reference	Vesrah Ref	Order No.
12314-MAF-000	VV-1048	<b>619-048</b>
12314-MN5-000	VV-1048	<b>619-048</b>
12316-283-310A, 12393-283-010B	VV-1015	<b>619-035</b>
12328-413-830	VV-1014	<b>619-007</b>
12328-415-000	VV-1004	<b>619-004</b>
12328-MG9-000	VV-1038	<b>619-038</b>
12391-149-003	VV-1019	<b>619-009</b>
12391-286-306	VV-1008	<b>619-031</b>
12391-300-306	VV-1003	<b>619-003</b>
12391-323-000	VV-1013	<b>619-006</b>
12391-333-000	VV-1006	<b>619-030</b>
12391-371-006	VV-1001	<b>619-001</b>
12391-425-010	VV-1002	<b>619-002</b>
12391-HB3-004	VV-1036	<b>619-026</b>
12391-HB3-013	VV-1036	<b>619-026</b>
12392-HC4-005	VV-1005	<b>619-005</b>
12391-KAS-901	VV-1033	<b>619-023</b>
12391-KB4-670	VV-1024	<b>619-014</b>
12391-KCY-671	VV-1056	<b>619-056</b>
12391-KE7-010	VV-1026	<b>619-016</b>
12391-KF0-014	VV-1033	<b>619-023</b>
12391-KR3-000	VV-1024	<b>619-014</b>
12391-KR6-010	VV-1032	<b>619-022</b>
12391-MB4-000	VV-1031	<b>619-021</b>
12391-MB6-000	VV-1029	<b>619-019</b>
12391-MF5-750	VV-1025	<b>619-015</b>
12391-MJ0-000	VV-1028	<b>619-018</b>
12391-MJ1-761	VV-1028	<b>619-018</b>
12391-ML7-000	VV-1041	<b>619-041</b>
12391-MM5-000	VV-1043	<b>619-043</b>
12391-MN4-000	VV-1044	<b>619-044</b>
12391-MT3-000	VV-1059	<b>619-059</b>
12391-MT4-000	VV-1047	<b>619-047</b>
12391-MV9-670	VV-1050	<b>619-050</b>
12391-MW0-000	VV-1054	<b>619-054</b>

### Kawasaki

11009-1365	VV-4017	<b>619-617</b>
11009-1483	VV-4016	<b>619-616</b>
11009-1497	VV-4014	<b>619-614</b>
11009-1559	VV-4022	<b>619-622</b>
11009-1607	VV-4015	<b>619-615</b>
11009-1724	VV-4019	<b>619-619</b>
11060-1280, 11009-1280	VV-4011	<b>619-609</b>
11060-1415, 11009-1025	VV-4003	<b>619-613</b>
11060-1416, 11009-1065	VV-4006	<b>619-605</b>
11060-1427, 11023-008	VV-4002	<b>619-602</b>
11060-1471, 11009-1095	VV-4009	<b>619-607</b>
11060-1537, 11009-1237	VV-4008	<b>619-608</b>

## Sudco Part Number to OEM Cross Reference Valve Cover Gaskets

### Kawasaki

OEM Reference	Vesrah Ref	Order No.
11060-1581, 11009-1050	VV-4004	<b>619-603</b>
11060-1582, 11009-1058	VV-4005	<b>619-604</b>
11060-1603, 11009-1274	VV-4012	<b>619-610</b>
11060-1605, 11023-006	VV-4001	<b>619-601</b>
11060-1691, 11060-1535, 11009-1205	VV-4007	<b>619-606</b>

### Suzuki

11173-06B02	VV-3024	<b>619-329</b>
11173-15502	VV-3017	<b>619-327</b>
11173-17E11	VV-3025	<b>619-330</b>
11173-21E00	VV-3026	<b>619-331</b>
11173-27A02	VV-3023	<b>619-328</b>
11173-31302	VV-3016	<b>619-326</b>
11173-44005, 11173-44004	VV-3001	<b>619-301</b>
11173-45003, 11173-45002, 11173-45001	VV-3002	<b>619-302</b>
11173-45004-H17, 11173-45004	VV-3002	<b>619-302</b>
11173-47004-H17, 11173-47004	VV-3005	<b>619-304</b>
11173-49004-H17, 11173-49004	VV-3003	<b>619-303</b>
11173-49022, 11173-49021	VV-3019	<b>619-306</b>
11173-49201	VV-3006	<b>619-305</b>
11173-49207-H17, 11173-49203	VV-3006	<b>619-305</b>
11173-49224-H17, 11173-49224	VV-3007	<b>619-307</b>
11173-49224-H17, 11173-49222	VV-3020	<b>619-320</b>

### Yamaha

1J7-11193-00-00	VV-2001	<b>619-201</b>
1WG-11193-00-00	VV-2015	<b>619-215</b>
2H7-11193-00-00	VV-2003	<b>619-203</b>
3GM-11193-00-00, 1AA-11193-00-00	VV-2011	<b>619-211</b>
3KM-1113-00-00, 4G0-11193-00-00	VV-2014	<b>619-206</b>
4H7-11193-00-00	VV-2002	<b>619-202</b>
5EA-11193-00-00, 36Y-11193-00-00	VV-2010	<b>619-210</b>
5G2-11193-00-00	VV-2013	<b>619-213</b>
12R-11193-00-00	VV-2008	<b>619-205</b>
30X-11193-00-00	VV-2009	<b>619-209</b>



620-992

620-981

## Sudco Part Number to OEM Cross Reference Camshaft End Rubber Plugs

### Kawasaki

OEM Reference	Vesrah Ref.	Order No.
92066-017 (4 pc. set)	AP-4001-4	<b>620-990</b>
92055-1104 all rubber (4 pc. set)	AP-4004-4	<b>620-993</b>
92055-1106 metal/rubber (4 pc. set)	AP-4003-4	<b>620-992</b>
92066-1111 (4 pc. set)	AP-4002-4	<b>620-991</b>

See page 344 for Kawasaki Billet Cam Cover End Plugs.

### Suzuki

09241-23002 (4 pc. set)	AP-3001-4	<b>620-981</b>
-------------------------	-----------	----------------

### Yamaha

1J7-11138-00-00 (4 pc. set)	AP-2002-4	<b>620-998</b>
-----------------------------	-----------	----------------

# Valve Cover Bolt Seals



621-903



621-900



621-904

## Valve (Head) Cover Bolt Seals

Replacement bolt seal for valve cover bolts. Sold in 4 pc., 6 pc., and 10 pc. sets. *Made in Japan.*

### Honda Street

Model	Qt Req.	Year	Order No.
CM185T Twinstar	2	78-79	621-903
CM200T Twinstar	2	80-82	621-903
CB250 Nighthawk	2	91-97	621-903
CB250 Nighthawk 250	2	99-07	621-903
CM250C Custom	2	82-83	621-903
CMX250C Rebel	2	85-87	621-903
CMX250C	2	96-97	621-903
CMX250C	2	99-12	621-903
CMX250CD Rebel	2	1986	621-903
CMX250C2	2	99-00	621-903
NX250	8	88-90	621-900
VTR250 Interceptor	8	89-90	621-902
CB400F CB1	8	89-90	621-900
CMX450C Rebel	4	86-87	621-900
CX500	4	78-79	621-903
CX500C Custom	4	79-82	621-903
CX500D Deluxe	4	79-81	621-903
CX500TC Turbo	4	1982	621-903
GL500 Silverwing	4	81-82	621-903
GL500I Silverwing Interstate	4	81-82	621-903
VF500C V30 Magna	8	84-85	621-902
VF500F V30 Interceptor	8	84-86	621-902
CB600F (599)	6	2004	621-900
CB600F (599)	6	2006	621-900
CBR600F Hurricane	8	87-90	621-900
CBR600F2 Hurricane	6	91-94	621-900
CBR600F3 Hurricane	6	95-98	621-900
CBR600F4 Hurricane	3	99-06	621-900
CBR600RR	4	03-08	621-900
CBR600SJR Replica	6	1996	621-900
CBR600SE	6	1998	621-900
FSC600 Silverwing	4	2002	621-900
FSC600A Silverwing	4	03-06	621-900
FSC600D Silverwing	4	03-06	621-900
VT600C Shadow VLX	4	88-89	621-900
VT600C Shadow VLX	4	91-97	621-900
VT600C Shadow VLX	4	99-07	621-900
VT600CD Shadow VLX Deluxe	4	93-07	621-900
VT600CD2 Shadow VLX Deluxe	4	99-00	621-900
XL600V Transalp	4	89-90	621-900
CB650	6	1979	621-901
CB650 up to engine # 210624	2	1980	621-901
CB650 from engine # 210625 on	2	1980	621-902
CB650	2	81-82	621-902
CB650C up to engine # 210624	2	1980	621-901
CB650C from engine # 210625 on	2	1980	621-902
CB650C Custom	2	81-82	621-902
CB650SC Nighthawk 650	2	1982	621-902

### Honda Street

Model	Qt Req.	Year	Order No.
CX650C Custom	4	1983	621-903
CX650T Turbo	4	1983	621-903
GL650 Silverwing	4	1983	621-903
GL650I Silverwing Interstate	4	1983	621-903
NT650 Hawk GT	4	88-91	621-904
CB700SC Nighthawk S	8	84-86	621-900
VF700C Magna	8	84-87	621-904
VF700F Interceptor	8	84-87	621-904
VF700S Sabre	8	84-87	621-904
VFR700F Interceptor	8	1986	621-900
VFR700F2 Interceptor	8	86-87	621-900
CB750 Nighthawk 750	8	91-93	621-900
CB750 Nighthawk 750	8	95-03	621-900
CB750C Custom	8	80-82	621-902
CB750F Super Sport	8	79-80	621-901
up to engine # 2104665			
CB750F Super Sport	8	80-82	621-902
from engine # 2104666			
CB750K	8	79-80	621-901
up to engine # 2106514			
CB750K	8	80-82	621-902
from engine # 2106515			
CB750SC Nighthawk	8	82-83	621-902
RFV750R RC45	8	1994	621-900
VF750C V45 Magna	8	82-83	621-904
VF750C V45 Magna	8	1988	621-904
VF750C Magna	8	94-96	621-900
VF750C Magna	8	98-03	621-900
VF750CD Magna Deluxe	8	95-96	621-900
VF750C2 Magna Deluxe	8	97-00	621-900
VF750F V45 Interceptor	8	83-84	621-904
VF750S V45 Sabre	8	82-83	621-904
VFR750F Interceptor	8	1986	621-900
VFR750F	8	90-97	621-900
VT750DC Shadow Spirit 750	4	01-02	621-904
VT750DCA Shadow Spirit 750	4	03-06	621-904
VT750DCB Shadow Spirit 750	4	03-06	621-904
VFR800 Interceptor	8	02-07	621-900
VFR800A Interceptor ABS	8	02-07	621-900
VFR800FI Interceptor	8	98-01	621-900
CB900C Custom	8	80-82	621-902
CB900F Super Sport	8	81-82	621-902
CB900F (919)	6	02-07	621-900
CBR900RR	6	93-99	621-900
CBR929RE	4	2001	621-900
CBR929RR	4	00-01	621-900
CBR954RR	4	02-03	621-900
CB1000	8	94-95	621-900
CB1000C Custom	8	1983	621-902
CBR1000F Hurricane	8	87-88	621-900
CBR1000F Hurricane	8	90-91	621-900
CBR1000F Hurricane	8	93-96	621-900



621-902



620-985

## Honda Street

Model	Qt Req.	Year	Order No.
CBR1000RR	4	04-07	621-900
CBX1000 (1047cc)	8	79-82	621-901
GL1000 Goldwing	8	75-79	621-903
GL1000L Goldwing LTD	8	1976	621-903
RVT1000R RC51	6	00-06	621-900
VF1000F Interceptor	8	1984	621-904
VF1000R	8	85-86	621-904
VTR1000F Super Hawk	8	98-05	621-900
CB1100F Super Sport	8	1983	621-902
CBR1100XX Blackbird	6	97-03	621-900
GL1100 Goldwing	8	80-83	621-903
GL1100A Goldwing Aspencade	8	82-83	621-903
GL1100I Goldwing Interstate	8	80-83	621-903
ST1100	8	91-02	621-900
ST1100A ABS	8	92-02	621-900
VF1100C V65 Magna	8	83-86	621-904
VF1100S V65 Sabre	8	83-86	621-904
GL1200 Goldwing	8	1984	621-904
GL1200A Goldwing Aspencade	8	84-87	621-904
GL1200I Goldwing Interstate	8	84-87	621-904
GL1200L Goldwing LTD	8	1985	621-904
GL1200SEi Goldwing SEi	8	1985	621-904
ST1300		03-11	621-900
ST1300A ABS		03-11	621-900
GL1500 Goldwing	12	88-90	621-904
GL1500A Goldwing Aspencade	12	91-00	621-904
GL1500C Valkyrie	12	97-00	621-904
GL1500D Valkyrie	12	2003	621-904
GL1500CD Valkyrie	12	01-03	621-904
GL1500CT Valkyrie Tourer	12	97-00	621-904
GL1500CF Valkyrie Interstate	12	99-01	621-904
GL1500I Goldwing Interstate	12	91-96	621-904
GL1500SE Goldwing SE	12	90-00	621-904
GL1800 Goldwing	11	01-07	621-900
GL1800A Goldwing Interstate	11	01-05	621-900
NRX1800DA/DB Rune	11	2004	621-900
NRX1800EA/EB Rune	11	2004	621-900

## Honda ATV

TRX450R	3	04-07	621-900
---------	---	-------	---------

## Honda Dual Sport & Offroad

CRF250R	2	04-08	621-900
CRF250X	2	04-08	621-900
NX250	3	88-90	621-900
CRF450R	3	02-08	621-900
CRF450X	3	04-08	621-900

## Kawasaki Street

Model	Qt Req.	Year	Order No.
EL250B2/B3 Eliminator 250	4	88-89	620-985
EL250E1/E2/E3/E4 Eliminator 250 HS	4	91-94	620-985
EX250E1/E2 Ninja 250R	4	86-87	620-985
EX250F1-F19 Ninja 250R	4	88-05	620-985
EX250F6F/F7F/F8F Ninja 250R	4	06-08	620-985
KL250D2-D22 KLR250	4	85-05	620-985
KL250G4/G5/G6/G7 Super Sherpa	3	00-03	621-960
EN450A1-A6 LTD454	6	85-90	620-994
EN500A1-A7 Vulcan 500	6	85-90	620-994
EN500C1-C10 Vulcan 500 LTD	6	96-05	620-994
EN500C6F/C7F/C8F Vulcan 500 LTD	6	06-08	620-994
EX500A1-A7	6	87-93	620-994
EX500D1/D2/D3 Ninja 500	6	94-96	620-994
EX500D4-D12 Ninja 500R	6	97-05	620-994
EX500D6F-D8F Ninja 500R	6	06-08	620-994
ZL600A1/A2 Eliminator	6	86-87	620-994
ZL600B2/B3 Eliminator	6	96-97	620-994
ZX600A1/A2/A3 Ninja 600R	6	85-87	620-994
ZX600B1 Ninja 600RX	6	1987	620-994
ZX600C1-C10 Ninja 600R	6	88-97	621-960
ZX600D1/D2/D3/D4 Ninja ZX-6	8	90-93	621-960
ZX600E1-E10 Ninja ZX-6	8	93-02	621-960
ZX600E11/E12 ZZR600	8	03-04	621-960
ZX600F1/F2/F3 Ninja ZX-6R	6	95-97	621-960
ZX600G1/G2 Ninja ZX-6R	6	98-99	621-960
ZX600J1/J2/J3 Ninja ZX-6R	6	00-02	621-960
ZX600J4/J6F/J7F ZZR600	6	05-07	621-960
ZX600K1/M1 Ninja ZX-6RR	6	03-04	621-960
ZX600N1/N6F Ninja ZX-6RR	6	05-06	621-960
ZX600P7F Ninja ZX-6R	6	2007	621-960
ZX636B1/B2/C1/C6F/D6F ZX-6R	6	03-07	621-960
EX650A6F/A7F Ninja 650R	4	06-07	621-960
VN700A1 Vulcan	6	1985	620-994
VN750A2-A21 Vulcan 750	6	85-05	620-994
VN750A6F Vulcan 750	6	2006	620-994
ZR750K1/K6F Z750S	6	05-06	621-960
ZX750F1-F4 Ninja 750R	8	87-90	621-960
ZX750H1/H2 Ninja ZX-7	8	89-90	621-960
ZX750J1/J2 Ninja ZX-7	6	91-92	621-960
ZX750K1/K2 Ninja ZX-7R	6	91-92	621-960
ZX750L1/L2 /L3 Ninja ZX-7	6	93-95	621-960
ZX750M1/M2 Ninja ZX-7R	6	93-94	621-960
ZX750N1 Ninja ZX-7RR	6	1996	621-960
ZX750P1-P8 Ninja ZX-7R	6	96-03	621-960
VN800A1-A11 Vulcan 800	6	95-05	621-960
VN800B1-B10 Vulcan 800 Classic	6	96-05	621-960
VN800C Vulcan 800 Drifter	6		621-960
VN800E1-E6F Vulcan 800 Drifter	6	01-06	621-960
VN900B6F/B7F Vulcan 900 Classic	6	06-07	621-960
VN900C7F Vulcan 900 Custom	6	2007	621-960
VN900D6F/D7F Vulcan 900 Classic LT	6	06-07	621-960
ZL900A1/A2 Eliminator	6	85-86	620-994
ZX900A1/A2/A3 Ninja 900R	6	84-86	620-994
ZX900B1/B/B3/B4 Ninja ZX-9R	6	94-97	621-960
ZX900C1/C2 Ninja ZX-9R	6	98-99	621-960

# Valve Cover Bolt Seals

## Kawasaki Street

Model	Qt Req.	Year	Order No.
ZX900E1/E2 Ninja ZX-9R	6	00-01	621-960
ZX900F1/F2 Ninja ZX-9R	6	02-03	621-960
ZG1000A1-A20 Concours	6	86-05	620-994
ZG1000A6F Concours	6	2006	620-994
ZL1000A1 Eliminator	6	1987	620-994
ZR1000A1/A2/A3/A4/A6F/A7F Z1000	6	03-07	621-960
ZX1000A1/A2 Ninja 1000R	6	86-87	620-994
ZX1000B1/B2/B3 Ninja ZX-10	6	88-90	621-960
ZX1000C1/C2 Ninja ZX-10R	6	04-05	621-960
ZX1000D6F/D7F Ninja ZX-10R	6	06-07	621-960
ZR1100A1/A2/A3/A4	8	92-95	621-960
ZR1100C3/C4 ZRX1100	6	99-00	621-960
ZX1100C1-C4 Ninja ZX-11	6	90-93	621-960
ZX1100D1-D9 Ninja ZX-11	6	93-01	621-960
ZX1100E1/E2/E3 GPz	6	95-97	621-960
ZX1100F1 GPz (ABS)	6	1996	621-960
ZG1200A1/B1-B17 Voyager XII	8	86-03	621-960
ZR1200A1/A2/A3/A4/A5 ZRX1200	6	01-05	621-960
ZX1200A1/A2 Ninja ZX-12R	7	00-01	621-960
ZX1200B1-B4 Ninja ZX-12R	7	02-05	621-960
ZX1200C1-C4 ZZR1200	6	02-05	621-960

## Kawasaki ATV

KSF250A1-A17 Mojave 250	4	00-01	621-985
KSF250A18 KFX250 Mojave	4	2004	621-985
KSF450B8F KFX450R	3	2008	621-960

## Kawasaki Dual Sport & Offroad

KL250D2-D22 KLR250	4	85-05	620-985
KL250G4/G5/G6/G7 Super Sherpa	3	00-03	621-960
KLX250D2/D3/D4 KLX250R	3	94-96	621-960
KX250H6F/H7F KLX250S	3	06-07	621-960
KX250N1/N2 KX250F	3	04-05	621-960
KX250T6F/T7F KX250F	2	06-07	621-960
KLX300A2-A10 KLX300R	3	97-05	621-960
KLX300A6F/A7F	3	06-07	621-960
KLX450A8F KLX450R	3	2008	621-960
KX450D6F/D7F	3	06-07	621-960
KL600A1/B2/B2 KLR600	4	84-86	620-985
KL650A1-A9 KLR650	4	87-95	620-985
KL650A10-A19 KLR650	4	96-05	621-960
KL650A6F/A7F KLR650	4	06-07	621-960
KL650B2/B2 Tengai KLR650	4	90-91	620-985
KL650E8F KLR650	4	2008	621-960
KLX650A1/A2/A3 KLX650R	3	93-95	621-960
KLX650C1-C4 Dual Sport	3	93-96	621-960
KLX650D1 KLX650R	3	1996	621-960

## Yamaha Street

SRX250T/TC	5	1987	621-922
XT250L/LC Dual Sport	5	1984	621-920
XT350N/NC-A/AC Dual Sport	5	85-90	621-920
XT350B/BC-M/MC Dual Sport	5	91-00	621-922
FZR400U/SUC/W/SWC/A/SAC	8	88-90	621-922
XJ550H/J/K Maxim (inner) Mount 1	4	81-83	621-920
XJ550H/J/K Maxim (outer) Mount 2	8	81-83	621-923
XJ550RH/RJ/RK Seca (inner) 1	4	81-83	621-920
XJ550RH/RJ/RK Seca (outer) 2	8	81-83	621-923
XZ550R/RK Vision	8	82-83	621-920
FJ600L/LC/N/NC (inner only)	4	84-85	621-920
FZ600S/SC/T/TC/U/UC (inner only)	4	86-88	621-920
FZ600SS/SSC-W/WC (FZ6)	8	04-07	621-921
FZR600W/WC/AC	8	89-90	621-922
FZR600RA/RAC-RL/RLC	8	90-99	621-922
XJ600SD/SDC-SK/SKC Seca II	8	92-98	621-921

## Yamaha Street

Model	Qt Req.	Year	Order No.
YX600S/SC-A/AC (inner only) 1	4	86-90	621-920
YZF600RG/RGC-RW/RWC	8	95-07	621-922
YZF-R6L/LC-T/TC	6	99-05	621-921
XJ650J/K Maxim (inner) Mount 1	4	82-83	621-920
XJ650J/K Maxim (outer) Mount 2	8	82-83	621-923
FZ700T/TC	8	1987	621-922
FZX700S/SC/T/TC Fazer	8	86-87	621-922
XJ700N/NC/S/SC (inner) Mount 1	4	85-86	621-920
XJ700N/NC/S/SC (outer) Mount 2	8	85-86	621-923
XJ700X Maxim X	8	85-86	621-922
FZ750N/NC/S/SC	8	85-86	621-922
FZ750U/UC	8	1988	621-922
FZR750RT/RU	8	87-88	621-922
XJ750J/K Maxim (inner) Mount 1	4	82-83	621-920
XJ750J/K Maxim (outer) Mount 2	8	82-83	621-923
XJ750MK Midnight (inner) 1	4	1983	621-920
XJ750MK Midnight (outer) 2	8	1983	621-923
XJ750RH/RJ/RK Seca (inner) 1	4	81-83	621-920
XJ750RH/RJ/RK Seca (outer) 2	8	81-83	621-923
YZF750RF/RFC	8	1994	621-922
YZF750RH/RHC-RK/RKC	8	96-98	621-922
TDM850D/DC/E/EC	4	92-93	621-922
XJ900RK Seca	8	1983	621-922
FZ1000N/NC-T/TC (FZ1)	8	01-05	621-921
FZR1000T/TC-G/GC	8	87-95	621-922
YZF1000R/J/RJC	8	1997	621-921
YZF-R1K/KC-S/SC	6	98-04	621-921
FJ1100L/LC/N/NC	8	84-85	621-922
FJ1200S/SC/T/TC	8	86-87	621-922
FJ1200W/WC-D/DC	8	89-92	621-922
VMX12N/NC/S/SC V-Max	16	85-86	621-922
VMX12U/UC-W1/W1C V-Max	16	88-07	621-922
XVZ12TK/L/KC2 Venture	16	83-84	621-922
XVZ12DL/DN Venture Royale	16	84-85	621-922
XVZ12DKC2	16	1984	621-922
FJR1300AS/ASC/AT/ATC (ABS)	8	04-05	621-921
FJR1300R/RC-T/TV	8	03-05	621-921
XVZ13T/TC/U/UC Venture	16	87-88	621-922
XVZ13DS-DEC Venture Royale	16	86-93	621-922

## Yamaha ATV

YZF450BBV/BBW	2	06-07	621-921
YZF450LES	2	2004	621-921
YZF450S/T/W/W	2	04-07	621-921
YZF450SET/SPV/SEW	2	05-07	621-921

## Yamaha Dual Sport & Offroad

TT-R250L/LC-V/VC	2	99-06	621-921
TT-R250L/LC-V/VC	1	99-06	621-922
WR250FN/FP/FR/FS/FT/FV	2	01-06	621-921
XT250L/LC Dual Sport	5	1984	621-920
YZ250FN/FP/FR/FS/FT/FV	2	01-06	621-921
TT350S/T	5	86-87	621-920
XT350N/NC-A/AC Dual Sport	5	85-90	621-920
XT350B/BC-M/MC Dual Sport	5	91-00	621-922
WR400FK/FL/FM	2	98-00	621-921
YZ400FK/FL	2	98-99	621-921
WR426FN/FP	2	01-02	621-921
YZ426FM/FN/FP	2	00-02	621-921
WR450FR/FS/FT/FV	2	03-06	621-921
YZ450FR/FS/FT/FV	2	03-06	621-921



## Valve Cover Bolt Seals

### Sudco Part Number to OEM Cross Reference

#### Honda

OEM Reference	Qt. Sold	Order No.
90541-371-000	pk/10	<b>621-903</b>
90541-422-000	pk/10	<b>621-901</b>
90541-425-000	pk/10	<b>621-902</b>
90542-MB0-000	pk/10	<b>621-904</b>
90543-MA6-000 (see 90543-MV9-670)	pk/10	<b>621-900</b>
90543-MV9-670	pk/10	<b>621-900</b>

#### Kawasaki

92055-1225	pk/4	<b>620-985</b>
92055-1225	pk/6	<b>620-994</b>
92055-1352	pk/10	<b>621-960</b>

#### Yamaha

2GH-1111G-00-00	pk/10	<b>621-922</b>
4G0-1111G-00-00	pk/10	<b>621-920</b>
4KG-1111G-00-00	pk/10	<b>621-921</b>
4U8-1112G-00-00	pk/10	<b>621-923</b>



### Sealing Rubber

Honda applications. Sold pk/6. *Made in Japan.*

#### Honda

OEM Reference 91318-300-013 Order No. **620-710**

Model	Year
CB500K0/K1/K2	71-73
CB550F Super Sport	75-77
CB550K0/K1	74-75
CB550K	76-78
CB650	79-82
CB650C Custom	80-81
CB650SC Nighthawk 650	1982
CB750A Automatic	76-78
CB750F Super Sport	75-78
CB750K0/K1/K2/K3/K4/K5	69-75
CB750K	76-78



**621-903**



**621-904**



## Timing Belt Cover Bolt Seals

Honda GL applications. Sold qt.10. *Made in Japan.*

#### Honda

Model	Qt Req.	Year	Order No.
GL1000	4	75-79	<b>621-903</b>
GL1000L Goldwing LTD	4	1976	<b>621-903</b>
GL1100 Goldwing	4	80-83	<b>621-903</b>
GL1100A Goldwing Aspencade	4	82-83	<b>621-903</b>
GL1100I Goldwing Interstate	4	80-83	<b>621-903</b>
GL1200 Goldwing	4	1984	<b>621-904</b>
GL1200A Goldwing Aspencade	4	84-87	<b>621-904</b>
GL1200I Goldwing Interstate	4	84-87	<b>621-904</b>
GL1200L Goldwing LTD	4	1985	<b>621-904</b>
GL1200SEI Goldwing SEI	4	1986	<b>621-904</b>

## Rubber O-Ring Camshaft Holder

Honda applications. Sold each. *Made in Japan.*

#### Honda

OEM Reference 91311-425-000 Order No. **620-700**

Model	Year
CB750C Custom	80-82
CB750F Super Sport	79-82
CB750K	79-82
CB750L LTD	1979
CB750SC Nighthawk	82-83
CB900C Custom	80-82
CB900F Super Sport	81-82
CB1000C Custom	1983
CB1100F Super Sport	1983

# Cover Seals (Rubber Parts)



## Valve Cover O-Ring Seal (Spark Plug Hole)

Replacement o-ring seal for spark plug hole. Sold in 2 piece set.  
*Made in Japan.*

### Suzuki Street

Model	Year	Cover 2	Cover 3.
GSF600ST/SV/SW/SX/SY Bandit	96-00	<a href="#">620-996</a>	<a href="#">620-980</a>
GSF600SK1/SK2/SK3 Bandit	01-03	<a href="#">620-996</a>	<a href="#">620-980</a>
GSX600FJ-FY Katana	88-00	<a href="#">620-996</a>	<a href="#">620-980</a>
GSX600FK1-FK5 Katana	01-05	<a href="#">620-996</a>	<a href="#">620-980</a>
GSX750FK-FV Katana	89-00	<a href="#">620-996</a>	<a href="#">620-980</a>
GSX750FK1-FK5 Katana	01-05	<a href="#">620-996</a>	<a href="#">620-980</a>
GSX-R750RG	1986	<a href="#">620-996</a>	<a href="#">620-980</a>
GSX-R750G/H/J/K/L/M/N	86-92	<a href="#">620-996</a>	<a href="#">620-980</a>
GSX1100FJ/FK/FL/FM/FN/FP Katana	88-93	<a href="#">620-996</a>	<a href="#">620-980</a>
GSX1100GM/GN/GP Shaft	91-93	<a href="#">620-996</a>	<a href="#">620-980</a>
GSX-R1100G/H/J	86-88	<a href="#">620-996</a>	<a href="#">620-980</a>
GSX-R1100K/L/M/N	89-92	<a href="#">620-996</a>	<a href="#">620-980</a>
GSF1200SV/SW/SX/SY Bandit	97-00	<a href="#">620-996</a>	<a href="#">620-980</a>
GSF1200SK1-/SK5 Bandit	01-05	<a href="#">620-996</a>	<a href="#">620-980</a>
GSF1200SAV Bandit	1997	<a href="#">620-996</a>	<a href="#">620-980</a>

## Valve Cover O-Ring Seal (Spark Plug Hole)

Replacement o-ring seal for spark plug hole. Sold in 4 piece set.  
*Made in Japan.*

### Suzuki Street

Model	Year	Order No.
GSX-R600WN/WP	92-93	<a href="#">620-997</a>
RF600RR/RS/RT	94-96	<a href="#">620-997</a>
GSX-R750WP/WR/WS	93-95	<a href="#">620-997</a>
RF900RR/RS/RT/RV	94-97	<a href="#">620-997</a>
SV1000K2-K7	03-07	<a href="#">620-997</a>
SV1000SK2-SK7	03-07	<a href="#">620-997</a>
TL1000RW/RX/RV/RK1/RK2/RK3	98-03	<a href="#">620-997</a>
TL1000SV/SW/SX/SY/SK1	97-01	<a href="#">620-997</a>
GSX-R1100WP/WR/WS/WT/WW/WWW	93-98	<a href="#">620-997</a>

## Sudco Part Number to OEM Cross Reference Valve Cover O-Ring Seal (Spark Plug Hole)

OEM Reference	Vesrah Ref.	Order No.
11178-27A01 No. 2 inner (Cover 2)	2 pc. set AK-3002	<a href="#">620-996</a>
11179-27A02 No. 3 outer (Cover 3)	2 pc. set AK-3003	<a href="#">620-980</a>
11173-17E00	4 pc. set AK-3006	<a href="#">620-997</a>





## Cylinder Head Cover Bolt Seals

Replacement seals sold in 8 pc. set. *Made in Japan.*

### Kawasaki ATV, Dual Sport & Offroad

Model	OEM Ref. 92200-S015	Year	620-970
KLX400A1	KLX400SR Dual Sport	2003	use qt2
KLX400B1	KLX400R Offroad	2003	use qt2
KSF400A1/A2/A3	KFX400 ATV	03-05	use qt2
KSF400A6F	KFX400 ATV	2006	use qt2

### Suzuki Street

Model	OEM Ref. 09161-11008/11006	Year	620-970
DR-Z400SY/SK1/SK2/SK3	Dual Sport	00-03	use qt2
DR-Z400SK4/SK5/SK6	Dual Sport	04-06	use qt2
DR-Z400SMK5/SMK6	Supermotard	05-06	use qt2
GSF400M/N/P	Bandit	91-93	use qt6
GSF600ST/SV/SW/SX/SY	Bandit	96-00	use qt8
GSF600SK1/SK2/SK3	Bandit	01-03	use qt8
GSX600FJ/FK/FL/FM/FN	Katana	88-92	use qt8
GSX600FP/FR/FS/FT/FV/FW/FX/FY	Katana	93-00	use qt8
GSX600FK1-FK6	Katana	01-06	use qt8
GSX-R600WN/WP		92-93	use qt8
GSX-R600V/W/X/Y/K1/K2/K3/K4/K5		97-05	use qt6
RF600RR/RS/RT		94-96	use qt8
DL650		04-06	use qt8
SV650X/Y/K1/K2/K3/K4/K5/K6		99-06	use qt4
SV650SX/SY/SK1/SK2/SK3/SK4/SK5/SK6		99-06	use qt4
GS700EF/ESF		1984	use qt8
GV700GLF/GLF2	Madura	1985	use qt12
GS750ED/ESD		1983	use qt8
GSX750FK/FL/FM/FN/FP	Katana	89-93	use qt8
GSX750FR/FS/FT/FV	Katana	94-97	use qt8
GSX750FW/FX/FY/FK1-FK6	Katana	98-06	use qt8
GSX-R750RG		1986	use qt8
GSX-R750G/H/J/K		86-89	use qt8
GSX-R750L/M/N		90-92	use qt6
GSX-R750WP/WR/WS		93-95	use qt6
GSX-R750T/V/W/X/Y/K1/K2/K3/K4/K5		96-05	use qt6
RF900RR/RS/RT/RV		94-97	use qt8
RF900RZS		1995	use qt8
DL1000K2/K3/K4/K5/K6	V-Storm	02-06	use qt8
GSX-R1000K1/K2/K3/K4/K5/K6		01-06	use qt6
TL1000RW/RX/RY/RK1/RK2/RK3		98-03	use qt8
TL1000SV/SW/SX/SY/SK1		98-01	use qt8
GSX1100FJ/FK/FL/FM/FN/FP	Katana	88-93	use qt8
GSX1100GM/GN/GP	Shaft	91-93	use qt8
GSX-R1100G/H/J		86-88	use qt8
GSX-R1100K/L/M/N		89-92	use qt8
GSX-R1100WP/WR/WS/WT/WV/WW		93-98	use qt8
GS1150ES3/ESE/EF/ESF/EF2/EG/ESG		83-86	use qt8
GSF1200SV/SAV/SW/SX/SY/SK1-SK5	Bandit	97-05	use qt8
GV1200GLF/GLF2/GLG	Madura	85-86	use qt12
GSX1300RX/RX/RK1-RK5	Hayabusa	99-05	use qt6
GV1400GDG/GDH/GDJ	Cavalcade	86-88	use qt12
GV1400GTG/GTH	Cavalcade	86-87	use qt12
GV1400GCG/GCH	Cavalcade	86-87	use qt12

## Suzuki ATV, Dual Sport & Offroad

Model	OEM Ref. 09161-11008	Year	620-970
DR-Z400Y/K1/K2/K3/K4	Offroad	00-04	use qt2
DR-Z400SY/SK1/SK2/SK3/SK4	Dual Sport	00-04	use qt2
DR-Z400SK5/SK6	Dual Sport	05-06	use qt2
DR-Z400SMK5/SMK6	Supermotard	05-06	use qt2
DR-Z400EY/EK1/EK2/EK3/EK4	Offroad	00-04	use qt2
DR-Z400EK5/EK6	Offroad w/Electric Start	05-06	use qt2
LT-Z400K3-K7	Z400 QuadSport ATV	03-07	use qt2

## Sudco Part Number to OEM Cross Reference Cylinder Head Cover Bolt Seals

### Kawasaki

OEM Reference	Vesrah Ref.	Order No.
92200-S015	4pc. set AH-3005	620-970

### Suzuki

OEM Reference	Vesrah Ref.	Order No.
09161-11006	4pc. set AH-3005	620-970
09161-11008	4pc. set AH-3005	620-970



## Z1 Tach Cable Guide Kit

Kit includes tach cable gear holder, o-ring and tach oil seal.

*Made in Japan.*

Order No. 900-173

### Kawasaki

Model	Year
Z1/ A/ B-900	73-75
KZ900A4 up to engine 135980	76-77
KZ900B1 LTD up to engine 135980	1976



## Z1 Tachometer Cable

Tachometer cable for the above Z1-900/KZ900 applications. Sold each.

Order No. 653-601

# Vesrah Valve Stem Seals & Valve Keepers



## Valve Stem Seals & Valve Keepers

Valve Stem Seals are sold pk/10. Valve Keepers sold each. **Made in Japan.** Valve Keeper quantity required for all engine valves is shown after Valve Keeper order number. **Sudco part number + (4) = Qt4, (8) = Qt8.**

### Honda Street

Model	Year	Valve Stem Seal Pk/10	Valve Keeper Each
C70 Passport	80-83	620-001	_____
C70K1 Honda 70	72-73	620-001	_____
C70M Honda 70	70-71	620-001	_____
CL70/K1/K2/K3 Scrambler	69-73	620-001	_____
CL90 Scrambler 90	67-69	620-001	_____
CB100K0/K1/K2 Super Sport	70-72	620-009	621-001 (4)
CL100K0/K1/K2 Scrambler	70-72	620-009	621-001 (4)
CL100S/S2/S3 Scrambler 100S	71-73	620-009	621-001 (4)
SL100K0/K1/K2/K3 Motosport	70-73	620-009	621-001 (4)
CB125S/S1/S2	73-75	620-009	621-001 (4)
CB125S	1976	620-009	621-001 (4)
CB125S	78-85	620-009	621-001 (4)
CB125TT	1990	620-006	621-001 (8)
CL125S/S1 Scrambler 125	73-74	620-009	621-001 (4)
NX125	88-89	620-006	621-003 (4)
SS125A Super Sport 125	67-69	620-001	_____
CA175 (CD175) Touring 175	68-69	620-001	_____
CA175K3 Touring 175	69-70	620-001	_____
CB175K3-K7 Super Sport 175	69-73	620-001	_____
CL175K0 Scrambler 175	68-69	620-001	_____
CL175K3-K7 Scrambler 175	69-73	620-001	_____
CM185T Twinstar	78-79	620-009	621-001 (8)
CM200T Twinstar	80-82	620-009	621-001 (8)
CB250 Nighthawk	91-97	620-006	621-001 (8)
CB250 Nighthawk	99-07	620-006	621-001 (8)
CM250C	82-83	620-006	621-001 (8)
CMX250C Rebel	85-87	620-006	621-001 (8)
CMX250C Rebel	96-97	620-006	_____
CMX250C Rebel	99-12	620-006	_____
CMX250CD Rebel	1986	620-006	621-001 (8)
CMX25C2 Rebel	99-00	620-006	_____
VTR250 Interceptor	88-90	620-010	621-002 (16)
CB350F/F1 (4 cylinder)	72-74	620-009	621-001 (16)
CB400A Automatic	1978	620-006 In	621-001 (8) In
		620-012 Ex	_____
CB400F Super Sport	75-77	620-009	621-001 (16)
CB400T Hawk	80-81	620-006 In	621-001 (8) In
		620-012 Ex	_____
CB400T1/TII Hawk	78-79	620-006 In	621-001 (8) In
		620-012 Ex	_____
CM400A Automatic	79-80	620-006 In	621-001 (8) In
		620-012 Ex	_____
CM400C Custom	1981	620-006 In	621-001 (8) In
		620-012 Ex	_____
CM400E	80-81	620-006 In	621-001 (8) In
		620-012 Ex	_____
CM400T	79-81	620-006 In	621-001 (8) In
		620-012 Ex	_____
CB450SC Nighthawk	82-86	620-006 In	621-001 (8) In
		620-012 Ex	_____
CB450T Hawk	1982	620-006 In	621-001 (8) In
		620-012 Ex	_____
CM450A Automatic	82-83	620-006 In	621-001 (8) In
		620-012 Ex	_____

### Honda Street

Model	Year	Valve Stem Seal Pk/10	Valve Keeper Each
CM450C Custom	1982	620-006 In	621-001 (8) In
		620-012 Ex	_____
CM450E	82-83	620-006 In	621-001 (8) In
		620-012 Ex	_____
CMX450C Rebel	86-87	620-006 In	621-001 (8) In
		620-012 Ex	_____
CB500/KI/K2	71-73	620-009	621-001 (16)
CX500	78-79	620-002	_____
CX500C Custom	79-82	620-002	_____
CX500D Deluxe	79-81	620-002	_____
CX500TC	1982	620-002	_____
FT500 Ascot	82-83	620-005	_____
GL500 Silverwing	81-82	620-002	_____
GL500I Silverwing Interstate	81-82	620-002	_____
VF500C V30 Magna	84-85	620-010	621-002 (32)
VF500F Interceptor	84-86	620-010	621-002 (32)
VT500C Shadow 500	83-86	620-006 In	621-003 (8) In
		620-012 Ex	_____
VT500FT Ascot	83-84	620-006 In	621-003 (8) In
		620-012 Ex	_____
CB550F Super Sport	75-77	620-009	621-001 (16)
CB550/K1/K	74-78	620-009	621-001 (16)
CBR600F Hurricane	87-90	620-010	621-002 (32)
CBR600F2 Hurricane	91-94	620-015	_____
CBR600F3 Hurricane	95-98	620-015	_____
CBR600SJR	1996	620-015	_____
CBR600SE	1998	620-015	_____
CBR600F4 Supersport	99-06	620-015	_____
VT600C Shadow VLX	88-89	620-006 In	621-003 (8) In
		620-005 Ex	_____
VT600C Shadow VLX	91-07	620-006 In	_____
		620-012 Ex	_____
VT600CD Shadow VLX Deluxe	93-07	620-006 In	_____
		620-012 Ex	_____
VT600CD2 Shadow VLX Deluxe	99-00	620-006 In	_____
		620-012 Ex	_____
NT650 Hawk GT	88-91	620-006 In	621-003 (8) In
		620-012 Ex	_____
NX650	88-89	620-005	_____
CB650	79-82	620-009	621-001 (16)
CB650C Custom	80-81	620-009	621-001 (16)
CB650SC Nighthawk	1982	620-009	621-001 (16)
CB650SC Nighthawk 650	83-85	620-010	621-002 (32)
CX650C Custom	1983	620-002	_____
CX650T Turbo	1983	620-002	_____
GL650 Silverwing	1983	620-002	_____
GL650I Silverwing Interstate	1983	620-002	_____
CB700SC Nighthawk	84-85	620-010	621-002 (32)
VF700C Magna	84-87	620-006	621-003 (32)
VF700F Interceptor	84-85	620-006	621-003 (32)
VF700S Sabre	84-85	620-006	621-003 (32)
VFR700F/F2 Interceptor	86-87	620-006	621-003 (32)
VT700C Shadow	84-87	620-005	_____

# Vesrah Valve Stem Seals & Valve Keepers

## Honda Street

Model	Year	Valve Stem Seal Pk/10	Valve Keeper Each
CB750A Automatic	76-78	620-002	_____
CB750C Custom	80-82	620-006	621-001 (32)
CB750F Super Sport	75-78	620-002	_____
CB750F Super Sport	79-82	620-006	621-001 (32)
CB750K0/K1-K5 750 Four	69-75	620-002	_____
CB750K 750 Four	1976	620-002	_____
CB750K 750 Four K	77-78	620-002	_____
CB750K 750 Four K	79-82	620-006	621-001 (32)
CB750L LTD	1979	620-006	621-001 (32)
CB750SC Nighthawk	82-83	620-006	621-001 (32)
VF750C V45 Magna	82-83	620-006	621-001 (32)
VF750C V45 Magna	1988	620-006	621-003 (32)
VF750C Magna	94-03	620-014 In	_____
VF750CD Magna	97-00	620-014 In	_____
VF750CD2 Magna Deluxe	95-96	620-014 In	_____
VF750F Interceptor	83-84	620-006	621-003 (32)
VF750S V45 Sabre	82-83	620-006	621-001 (32)
VFR750F Interceptor	1986	620-006	621-003 (32)
VFR750F	90-97	620-014	_____
VFR750R RC30	1990	620-014	_____
VT750C Shadow 750	1983	620-002	_____
VT750C Shadow 750 A.C.E.	98-00	620-006 In	621-003 (8) In
VT750C Shadow Aero	04-10	620-006 In	_____
VT750CA Shadow Aero	04-07	620-006 In	_____
VT750CD Shadow Deluxe	98-01	620-006 In	621-003 (8) In
VT750CD2 Shadow Deluxe	98-01	620-006 In	621-003 (8) In
VT750CDA Shadow A.C.E. 750 Deluxe	02-03	620-006 In	_____
VT750CDB Shadow A.C.E. 750 Deluxe	02-03	620-012 Ex	_____
VT750CDC Shadow A.C.E. 750 Deluxe	02-03	620-006 In	_____
VT750CDD Shadow A.C.E. 750 Deluxe	02-03	620-012 Ex	_____
VT750DC Shadow Spirit 750	01-02	620-006 In	621-003 (8) In
VT750DCA Shadow Spirit 750	2003	620-006 In	_____
VT750DCA Shadow Spirit 750	05-07	620-006 In	_____
VT750DCB Shadow Spirit 750	2003	620-006 In	_____
VT750DCAB Shadow Spirit 750	05-07	620-006 In	_____
PC800 Pacific Coast	89-90	620-005 In	_____
PC800 Pacific Coast	94-98	620-012 Ex	_____
VFR800 Interceptor	02-11	620-014	_____
VFR800A ABS	02-11	620-014	_____
VFR800FI	98-01	620-014	_____
VT800C Shadow	1988	620-005	_____
CB900C Custom	80-82	620-006	621-001 (32)
CB900F Super Sport	81-82	620-006	621-001 (32)
CBR900RR	93-99	620-014	_____
CBR929RR	00-01	620-014	_____
CBR954RR	02-93	620-014	_____

## Honda Street

Model	Year	Valve Stem Seal Pk/10	Valve Keeper Each
CB1000	94-95	620-006	621-003 (32)
CB1000C Custom	1983	620-006	621-001 (32)
CBR1000F Hurricane	87-88	620-006	621-003 (32)
CBR1000F Hurricane	90-91	620-006	621-003 (32)
CBR1000F Hurricane	93-96	620-006	621-003 (32)
CBR1000RA	09-10	620-015	_____
CBR1000RR	08-12	620-015	_____
GL1000 Gold Wing	75-79	620-002	_____
GL1000L LTD	1976	620-002	_____
VF1000F Interceptor	1984	620-006	621-003 (32)
VF1000R	85-86	620-006	621-003 (32)
CBX six cyl. Super Sport	79-82	620-006	621-001 (48)
CB1100F Super Sport	1983	620-006	621-001(32)
CBR1100XX Blackbird	97-03	620-010	_____
GL1100 Gold Wing	80-83	620-005	_____
GL1100A Goldwing Aspencade	82-83	620-005	_____
GL1100I Goldwing Interstate	80-83	620-005	_____
ST1100	91-02	620-014	_____
ST1100A (ABS)	92-02	620-014	_____
VF1100C V65 Magna	83-86	620-006	621-003 (32)
VF1100S V65 Sabre	84-85	620-006	621-003 (32)
VT1100C Shadow 1100	85-90	620-005	_____
VT1100C Shadow 1100	92-96	620-005	_____
VT1100C Shadow 1100 Spirit	97-07	620-012	_____
VT1100C2 Shadow 1100 A.C.E.	95-97	620-005	_____
VT1100C Shadow 1100 A.C.E.	98-99	620-012	_____
VT1100C2 Shadow 1100 A.C.E.	00-01	620-012	_____
VT1100C2 Shadow Sabre	00-07	620-012	_____
VT1100C2-2 Shadow 1100 A.C.E.	1997	620-005	_____
VT1100C3 Shadow Aero	98-02	620-012	_____
VT1100D2 Shadow 1100 A.C.E.	1999	620-012	_____
VT1100T Shadow 1100 A.C.E.Tourer	98-99	620-012	_____
GL1200 Gold Wing	1984	620-005	_____
GL1200A Aspencade	84-87	620-005	_____
GL1200I Interstate	84-87	620-005	_____
GL1200L Limited	1985	620-005	_____
GL1200SEI Aspencade	1986	620-005	_____
ST1300	03-11	620-010	_____
ST1300A	03-11	620-010	_____
VTX1300C	04-10	620-006	_____
VTX1300R	03-10	620-006	_____
VTX1300S Retro	03-07	620-006	_____
GL1500 Goldwing	88-90	620-006	_____
GL1500A Goldwing Aspencade	91-00	620-006	_____
GL1500C Valkyrie	97-00	620-006	_____
GL1500C Valkyrie	2003	620-006	_____
GL1500CDValkyrie	01-03	620-006	_____
GL1500CF Valkyrie Interstate	99-01	620-006	_____
GL1500CT Valkyrie Tourer	97-00	620-006	_____
GL1500I Goldwing Interstate	91-96	620-006	_____
GL1500SE Goldwing SE	90-00	620-006	_____
GL1800 Goldwing	01-05	620-010	_____
GL1800A Goldwing	01-05	620-010	_____
NRX1800DA Valkyrie Rune	2004	620-010	_____
NRX1800DB Valkyrie Rune	2004	620-010	_____
NRX1800EA Valkyrie Rune	2004	620-010	_____
NRX1800EB Valkyrie Rune	2004	620-010	_____
VTX1800C	02-04	620-010	_____
VTX1800C	02-08	620-012	_____
VTX1800F	05-07	620-012	_____
VTX1800N	04-11	620-012	_____
VTX1800R	02-08	620-012	_____
VTX1800S	02-07	620-012	_____

# Vesrah Valve Stem Seals & Valve Keepers

## Honda ATV

Model	Year	Valve Stem Seal Pk/10	Valve Keeper Each
ATC70K0/K1	73-74	620-001	_____
ATC70	78-85	620-001	_____
TRX70	86-87	620-001	_____
ATC90K0/K1/K2/K3	70-75	620-001	_____
ATC90	76-78	620-001	_____
TRX90 Fourtrax 90	93-01	620-010	_____
TRX90 Sportrax 90	02-09	620-010	_____
TRX90EX Sportrax90	07-08	620-010	_____
TRX90X	09-12	620-010	_____
ATC110	79-85	620-001	_____
ATC125M	84-87	620-006	621-001 (4)
TRX125 Fourtrax 125	85-86	620-006	621-001 (4)
TRX125 Fourtrax 125	87-88	620-006	621-003 (4)
ATC185	1980	620-006	621-001 (4)
ATC185S	81-83	620-006	621-001 (4)
ATC200	81-83	620-006	621-001 (4)
ATC200E	82-83	620-006	621-001 (4)
ATC200ES	1984	620-006	621-001 (4)
ATC200M	84-85	620-006	621-001 (4)
ATC200S	84-86	620-006	621-001 (4)
ATC200X	83-85	620-006	621-001 (4)
ATC200X	86-87	620-006	621-003 (4)
TRX200 Fourtrax 200	1984	620-006	621-001 (4)
TRX200 Fourtrax 200	90-91	620-006	_____
TRX200D Fourtrax 200 Type II	91-97	620-006	_____
TRX200SX Fourtrax	86-87	620-006	621-003 (4)
ATC250ES Big Red	85-86	620-006	621-003 (4)
ATC250ES Big Red	1987	620-006	_____
ATC250SX	85-86	620-006	621-003 (4)
ATC250SX	1987	620-006	_____
TRX250 Fourtrax 250	85-86	620-006	621-003 (4)
TRX250 Fourtrax 250	1987	620-006	_____
TRX250 Recon	97-01	620-006	_____
TRX250X Fourtrax	87-88	620-006	_____
TRX250X Fourtrax	91-92	620-006	_____
TRX250X Fourtrax	09-11	620-006	_____
TRX300 Fourtrax 300	88-00	620-006	_____
TRX300EX Fourtrax 300	93-00	620-006	_____
TRX300EX Sportrax 300	01-05	620-006	_____
TRX300FW Fourtrax 4x4	1988	620-006	_____
TRX300FW Fourtrax 4x4	90-00	620-006	_____
TRX300X Fourtrax	2009	620-006	_____
ATC350X	85-87	620-006	621-003 (8)
TRX350 Fourtrax 4 x 4	86-87	620-006	621-003 (8)
TRX350D Fourtrax Foreman 4x4	87-89	620-006	_____
TRX350FE Rancher 4x4 ES	00-06	620-006	_____
TRX350FM Rancher 4x4	00-06	620-006	_____
TRX350TE Rancher ES	00-06	620-006	_____
TRX350TM Fourtrax Rancher	00-06	620-006	_____
TRX400EX Fourtrax 400EX	99-00	620-006	_____
TRX400EX Sportrax 400EX	01-08	620-006	_____
TRX400FA Fourtrax Rancher AT	04-07	620-006	_____
TRX400FGA Fourtrax Rancher AT	04-06	620-006	_____
TRX400FM Fourtrax Foreman	2002	620-006	_____
TRX400FW Fourtrax Foreman	95-01	620-006	_____
TRX400FW Fourtrax Foreman	2003	620-006	_____
TRX450ES Fourtrax Foreman	98-01	620-006	_____
TRX450FE Fourtrax Foreman	02-04	620-006	_____
TRX450FM Fourtrax Foreman	02-04	620-006	_____
TRX450R	04-05	620-006	_____
TRX450X	06-09	620-006	_____
TRX450S Fourtrax Foreman S	98-01	620-006	_____
TRX500FA Rubicon	00-12	620-006	_____
TRX500FGA Fourman Rubicon	04-05	620-006	_____
TRX650FA Rincon	2003	620-006	_____
TRX650FA Fourtrax Rincon	03-05	620-006	_____
TRX650FGA Fourtrax Rincon Gpscape	04-05	620-006	_____

## Honda Dual Sport & Offroad

Model	Year	Valve Stem Seal Pk/10	Valve Keeper Each
CRF50F	04-09	620-010	_____
XR50R	00-03	620-010	_____
Z50AK0/AK1-AK6 Mini Trail 50	68-75	620-001	_____
Z50A Mini Trail 50	76-78	620-001	_____
Z50R	79-87	620-001	_____
Z50R	1988	620-010	_____
Z50R	91-00	620-001	_____
Z50RD Special	1986	620-001	_____
CRF70F	04-09	620-010	_____
CT70 Trail 70	76-82	620-001	_____
CT70 Mini Trail	91-94	620-010	_____
CT70H/HK1 Trail 70	70-73	620-001	_____
CT70K0/K1/K2/K3/K4 Trail 70	69-74	620-001	_____
SL70K0/K1 Motosport 70	71-73	620-001	_____
XL70K0/K1	74-75	620-001	_____
XL70	1976	620-001	_____
XR70R	97-03	620-010	621-002 (4)
XL75	77-79	620-009	621-001 (4)
XR75K0/K1//K2	73-75	620-009	621-001 (4)
XR75	76-78	620-009	621-001 (4)
CRF80F	04-12	620-006	621-001 (4)
XL80S	80-85	620-009	621-001 (4)
XR80	79-84	620-009	621-001 (4)
XR80R	85-91	620-009	621-001 (4)
XR80R	93-03	620-006	621-001 (4)
CT90	76-79	620-001	_____
CT90K0/K1-K6 Trail 90	66-75	620-001	_____
SL90 Motosport 70	1969	620-001	_____
ST90K0/K1/K2 Motosport 70	73-75	620-001	_____
CRF100F	04-12	620-006	621-001 (4)
SL100K0/K1/K2/K3 Motosport 100	70-73	620-006	621-001 (4)
XL100K0/K1	74-75	620-006	621-001 (4)
XL100	76-78	620-006	621-001 (4)
XL100S	79-85	620-006	621-001 (4)
XR100	81-84	620-006	621-001 (4)
XR100R	85-03	620-006	621-001 (4)
CT110 Trail 110	80-84	620-006	621-001 (4)
CT110 Trail 110	1986	620-006	621-001 (4)
CT125 Trail 125	1977	_____	621-001 (4)
NX125	88-89	620-006	621-003 (4)
SL125K1/K2 Motosport 125	71-73	620-006	621-001 (4)
TL125K0/K1/K2 Trials 125	73-75	620-006	621-001 (4)
TL125S Trials 125	1976	620-006	621-001 (4)
XL125K0/K1	74-75	_____	621-001 (4)
XL125	76-78	_____	621-001 (4)
XL125S	79-82	_____	621-001 (4)
XL125S	84-85	620-006	621-001 (4)
CRF150F	03-09	620-006	_____
XL185S	79-83	620-006	621-001 (4)
XR185	1979	620-006	621-001 (4)
TLR200 Reflex	86-87	620-006	621-001 (4)
TR200 Fatcat	86-87	620-006	621-003 (4)
XL200R	83-84	620-006	621-001 (4)
XR200	80-84	620-006	621-001 (4)
XR200R	81-83	620-006	621-001 (4)
XR200R	84-85	620-006	_____
XR200R	86-88	620-006	621-001 (4)
XR200R	90-91	620-006	621-001 (4)
XR200R	93-03	620-006	621-001 (4)
CRF230F	03-09	620-006	_____
CRF250R	04-09	620-010	_____
CRF250X	04-12	620-010	_____
TL250 Trials	75-76	620-009	621-001 (8)
XL250K0/K1/K2	72-75	620-009	621-001 (8)
XL250	1976	620-009	621-001 (8)
XL250R	82-83	620-006	621-001 (4)
XL250R	84-87	620-006	621-003 (8)

# Vesrah Valve Stem Seals & Valve Keepers

VINTAGE  
INTAKE  
ENGINE  
SUSPENSION  
CONTROL  
ELECTRICAL  
CHEMICAL  
TOOLS  
WATERCRAFT

## Honda Dual Sport & Offroad

Model	Year	Valve Stem Seal Pk/10	Valve Keeper Each
XL250S	78-81	620-006	621-001 (8)
XR250L	91-96	620-006	621-003 (8)
XR250	79-80	620-006	621-001 (8)
XR250R	81-82	620-006	621-001 (8)
XR250R	84-95	620-006	621-003 (8)
XR250R	96-04	620-010	621-002 (8)
XL350	76-78	620-009	621-001 (4)
XL350K0/K1	74-75	620-009	621-001 (4)
XL350R	84-85	620-006	621-003 (8)
XR350R	83-85	620-006	621-003 (8)
XR400R	96-04	620-006	_____
CRF450R	02-12	620-006	_____
CRF450X	05-12	620-006	_____
XL500R	1982	620-005	_____
XL500S	79-81	620-005	_____
XR500	79-80	620-005	_____
XL600R	83-87	620-005	_____
XL600V Transalp	89-90	620-006 In 620-012 Ex	621-003 (8) In _____
XR600R	85-00	620-005	_____
XR650L	93-12	620-005	_____
XR650R	00-07	620-012	_____

## Kawasaki Street

\*KZ400 (74-77) & \*KZ550A/C applications, (1980-1981). Order valve keeper required. Difference is keeper groove on valves.

BN125A4/A5 Eliminator 125	01-02	620-606	_____
BN125A7/A8 Eliminator 125	04-05	620-606	_____
BN125A6F-A9F Eliminator 125	06-09	620-606	_____
KZ200A1/A2	78-79	620-601	621-604 (4)
EL250B2/B3 Eliminator	88-89	620-604	621-605 (16)
EL250E1/E2/E3/E4 Eliminator	91-94	620-604	621-605 (16)
EX250E1/E2 Ninja 250R	86-87	620-604	621-605 (16)
EX250F2/F3/F4 Ninja 250R	88-90	620-604	621-605 (16)
EX250F6-F19 Ninja 250R	92-05	620-604	621-605 (16)
EX250F6F Ninja 250R	2006	620-604	621-605 (16)
EX250 J8F-JCF	08-12	620-606	_____
KZ250D1/D2 LTD & CSR	80-81	620-601	621-604 (4)
KZ250L1 CSR	1982	620-601	621-604 (4)
KZ250W1 LTD	1983	620-601	621-604 (4)
EX305B1 GPz Belt	1983	620-603	621-603 (8)
KZ305A1/A2 CSR	81-82	620-603	621-603 (8)
KZ305B1 CSR Belt	1981	620-603	621-603 (8)
KZ305B2/B3 LTD	87-88	620-603	621-603 (8)
KZ400A1/A2 Deluxe	77-78	620-601	621-604 (8)
KZ400B1/B2	78-79	620-601	621-604 (8)
KZ400C1	1978	620-601	621-604 (8)
KZ400/D *(see notes) up to engine 089779	74-75	620-601	621-606 (8)
KZ400/D/D3/D4 *(see notes) from engine 089779	74-77	620-601	621-604 (8)
KZ400H1 LTD	1979	620-601	621-604 (8)
KZ400S/S2/S3 Special *(see notes) up to engine 089779	75-77	620-601	621-606 (8)
KZ400S/S2/S3 Special *(see notes) from engine 089779	75-77	620-601	621-604 (8)
KZ440A1/A2/A3/A4 LTD	80-83	620-601	621-604 (8)
KZ440B1/B2	80-81	620-601	621-604 (8)
KZ440D1/D2/D3/D4/D5 LTD	80-83	620-601	621-604 (8)
KZ440G1 Belt	1982	620-601	621-604 (8)
EN450A1-A6 LTD 454	85-90	620-603	621-603 (16)
EN500A1-A7 Vulcan 500	90-96	620-603	621-603 (16)
EN500C1-C10 Vulcan 500 LTD	96-05	620-603	621-603 (16)
EN500C6F Vulcan 500 LTD	2006	620-603	621-603 (16)
EX500A1-A7	87-93	620-603	621-603 (16)
EX500D1/D2/D3 Ninja 500	94-96	620-603	621-603 (16)
EX500D4-D12 Ninja 500R	97-05	620-603	621-603 (16)

## Kawasaki Street

Model	Year	Valve Stem Seal Pk/10	Valve Keeper Each
EX500D6F-D9F Ninja 500R	06-09	620-603	621-603 (16)
KZ550A1/A2 *(see notes)	80-81	620-604	621-602 (16)
KZ550A1/A2 *(see notes)	80-81	620-604	621-603 (16)
KZ550A3/A4	82-83	620-604	621-603 (16)
KZ550C1/C2 LTD *(see notes)	80-81	620-604	621-602 (16)
KZ550C1/C2 LTD *(see notes)	80-81	620-604	621-603 (16)
KZ550C3/C4 LTD	82-83	620-604	621-603 (16)
KZ550D1 GPz	1981	620-604	621-603 (16)
KZ550F1 Spectre	1983	620-604	621-603 (16)
KZ550F2 LTD Shaft	1984	620-604	621-603 (16)
KZ550H1/H2 GPz	82-83	620-604	621-603 (16)
ZR550B1/B2/B3 Zephyr	90-92	620-604	621-603 (16)
ZX550A1/A2/A3 GPz	84-86	620-604	621-603 (16)
KL600A1 KLR600	1984	620-601	621-604 (8)
KL600B1/B2 KLR600	85-86	620-604	621-604 (8)
ZL600A1/A2 Eliminator	86-87	620-604	621-605 (32)
ZL600B2/B3 Eliminator	96-97	620-604	621-605 (32)
ZX600A1/A2/A3 Ninja 600R	85-87	620-604	621-605 (32)
ZX600B1 Ninja 600RX	1987	620-604	621-605 (32)
ZX600C1-C10 Ninja 600R	88-97	620-604	621-605 (32)
EJ650A1/A2/A3/A4 W650	99-02	620-606	_____
KL650A1-A19 KLR650	87-05	620-601	621-604 (8)
KL650A6F-A7F KLR650	06-07	620-601	621-604 (8)
KL650B2/B3 KLR650 Tengai	90-91	620-601	621-604 (8)
KLX650C1/C2/C3/C4 Dual Sport	93-96	620-601	621-604 (8)
KZ650B1/B2/B2A/B3	77-79	620-601	621-604 (16)
KZ650C1/C2/C3 Custom	77-79	620-601	621-604 (16)
KZ650D1/D1A SR	1978	620-601	621-604 (16)
KZ650D2 SR	1979	620-601	621-604 (16)
KZ650E1 LTD	1980	620-601	621-604 (16)
KZ650F1	1980	620-601	621-604 (16)
KZ650H1/H2/H3 CSR	81-83	620-601	621-604 (16)
KZ700A1	1984	620-601	621-604 (16)
VN700A1 Vulcan	1985	620-603	621-603 (16)
ZN700A1/A2 LTD	84-85	620-601	621-604 (16)
KZ750B1/B2/B3/B4 2-cyl.	76-79	_____	621-601 (8)
KZ750E1/E2/E3	80-82	620-601	621-604 (16)
KZ750F1 LTD Shaft	1983	620-601	621-604 (16)
KZ750G1 LTD 2-cyl.	1980	_____	621-601 (8)
KZ750H1/H2/H3/H4 LTD	80-83	620-601	621-604 (16)
KZ750K1/K2 LTD 2-cyl.	83-84	_____	621-601 (8)
KZ750L3	1983	620-601	621-604 (16)
KZ750M1 CSR 2-cyl.	1982	_____	621-601 (8)
KZ750N1/N2 Spectre	82-83	620-601	621-604 (16)
KZ750R1 GPz	1982	620-601	621-604 (16)
VN750A2-A21 Vulcan 750	86-05	620-603	621-603 (16)
VN750A6F Vulcan 750	2006	620-603	621-603 (16)
ZR750C1/C2/C3 Zephyr	91-93	620-601	621-604 (16)
ZR750F2 ZR-7	2000	620-601	621-604 (16)
ZR750H1/H2/H3 ZR-7S	01-03	620-601	621-604 (16)
ZX750A1/A2/A3 GPz	83-85	620-601	621-604 (16)
ZX750E1/E2 GPz Turbo	84-85	620-601	621-604 (16)
ZX750F1/F2/F3/F4 Ninja 750R	87-90	620-604	621-605 (32)
ZX750H1/H2 Ninja ZX-7	89-90	620-604	621-605 (32)
ZX750J1/J2 Ninja ZX-7	91-92	620-606	_____
ZX750K1/K2 Ninja ZX-7R	92-93	620-606	_____
ZX750L1/L2/L3 Ninja ZX-7	93-95	620-606	_____
ZX750M1/M2 Ninja ZX-7R	93-94	620-606	_____
ZX750P1-P8 Ninja ZX-7R	96-03	620-606	_____
VN800A1-A11 Vulcan 800	95-05	620-604	621-605 (16)
VN800B1-B10 Vulcan 800 Classic	96-05	620-604	621-605 (16)
VN800C1/C2 Vulcan 800 Drifter	99-00	620-604	621-605 (16)
VN800E1-E6F Vulcan 800 Drifter	01-06	620-604	621-605 (16)
KZ900A4/A5	76-77	620-601	621-606 (16)
KZ900B1 LTD	1976	620-601	621-606 (16)
KZ900C2 Police	1976	620-601	621-606 (16)



# Vesrah Valve Stem Seals & Valve Keepers

## Kawasaki Street

Model	Year	Valve Stem Seal Pk/10	Valve Keeper Each
Z1/A/B-900	73-75	620-601	621-606 (16)
ZL900A1/A2 Eliminator	85-86	620-603	621-603 (32)
ZX900A1/A2/A3 Ninja 900R	84-86	620-603	621-603 (32)
ZX900B1/B2/B3/B4 Ninja ZX-9R	94-97	620-606	—
ZX900C1/C2 Ninja ZX-9R	98-99	620-606	—
ZX900E1/E2 Ninja ZX-9R	00-01	620-606	—
KZ1000A1/A2	77-78	620-601	621-604 (16)
KZ1000A3/A3A/A4 MKII	79-80	620-601	621-604 (16)
KZ1000B1/B2/B3/B4 LTD	77-80	620-601	621-604 (16)
KZ1000C1/C1A/C2/C3/C4 Police	78-81	620-601	621-604 (16)
KZ1000D1 Z1R	1978	620-601	621-604 (16)
KZ1000D3 Z1R	1980	620-601	621-604 (16)
KZ1000E1/E2 Shaft ST	79-80	620-601	621-604 (16)
KZ1000J1/J2/J3	81-83	620-601	621-604 (16)
KZ1000K1/K2 LTD	81-82	620-601	621-604 (16)
KZ1000M1/M2 CSR	81-82	620-601	621-604 (16)
KZ1000P1-P21 Police	82-02	620-601	621-604 (16)
KZ1000P24 Police	2005	620-601	621-604 (16)
KZ1000R1/R2 Replica	82-83	620-601	621-604 (16)
ZG1000A1-A20 Concours	86-05	620-603	621-603 (32)
ZG1000A6F Concours	2006	620-603	621-603 (32)
ZL1000A1 Eliminator	1987	620-603	621-603 (32)
ZR1000A1/A2/A3 Z1000	03-05	620-606	—
ZX1000A1/A2 Ninja 1000R	86-87	620-603	621-603 (32)
ZX1000B1/B2/B3 Ninja ZX-10	88-90	620-604	621-605 (32)
ZX1000C1-JCF Ninja ZX-10R	04-12	620-606	—
KZ1100A1/A2/A3 Shaft	81-83	620-601	621-604 (16)
KZ1100B1/B2 GPz	81-82	620-601	621-604 (16)
KZ1100D1/D2 Spectre	82-83	620-601	621-604 (16)
KZ1100L1 LTD	1983	620-601	621-604 (16)
ZN1100B1/B2 LTD Shaft	84-85	620-601	621-604 (16)
ZR1100A1/A2/A3/A4	92-95	620-601	621-604 (16)
ZR1100C3/C4 ZRX1100	99-00	620-604	621-605 (32)
ZX1100A1/A2 GPz	83-84	620-601	621-604 (16)
ZX1100C1/C2/C3/C4 Ninja ZX-11	90-93	620-604	621-605 (32)
ZX1100D1-D9 Ninja ZX-11	93-01	620-604	621-605 (32)
ZX1100E1/E2/E3 GPz	95-97	620-604	621-605 (32)
ZX1100F1 GPz (ABS)	1996	620-604	621-605 (32)
ZG1200A1 Voyager XII	1986	620-603	621-603 (32)
ZG1200B1-B17 Voyager XII	87-03	620-603	621-603 (32)
ZR1200A1-A5 ZRX1200	01-05	620-604	621-605 (32)
ZX1200C1/C2/C3/C4 ZZR1200	02-05	620-604	621-605 (32)
KZ1300A1/A2/A3/A4	79-82	620-601	621-604 (24)
KZ1300B2 Touring	1980	620-601	621-604 (24)
ZN1300A1-A6 Voyager	83-86	620-601	621-604 (24)
VN1500A1-A9 Vulcan 88	87-95	620-601	621-604 (16)
VN1500A10-A13 Vulcan 1500	96-99	620-601	621-604 (16)
VN1500B1-B4 Vulcan 88 SE	87-90	620-601	621-604 (16)
VN1500C3/C4 Vulcan 1500L	96-97	620-601	621-604 (16)
VN1500D1/D2 Vulcan Classic	96-97	620-601	621-604 (16)
VN1500E1-E7 Vulcan 1500 Classic	98-04	620-601	621-604 (16)
VN1500G1/G1A/G2A/G3	99-01	620-601	621-604 (16)
Vulcan 1500 Nomad F.I.			
VN1500J1/J2 Vulcan 1500 Drifter	99-00	620-601	621-604 (16)
VN1500L1-L5 Vulcan 1500	00-04	620-601	621-604 (16)
Nomad F.I.			
VN1500N1-N3 Vulcan 1500 Classic	00-02	620-601	621-604 (16)
Classic F.I.			
VN1500N4 Vulcan 1500 Classic F.I.	2005	620-601	621-604 (16)
VN1500N6F Vulcan 1500 Classic	06-08	620-601	621-604 (16)
VN1500P1/P2 Vulcan 1500	02-03	620-601	621-604 (16)
Mean Streak			
VN1500R1-R5 Vulcan 1500 Drifter	01-05	620-601	621-604 (16)
VN1600A1/A2/A3 Vulcan 1600	03-05	620-601	621-604 (16)
Classic			
VN1600A6F Vulcan 1600 Classic	06-08	620-601	621-604 (16)

## Kawasaki Street

Model	Year	Valve Stem Seal Pk/10	Valve Keeper Each
VN1600B1-B8F Vulcan 1600	04-07	620-601	621-604 (16)
Mean Streak			
VN1600D1-D7F Vulcan 1600 Nomad	2005	620-601	621-604 (16)
VN1600D6F Vulcan 1600 Nomad	2006	620-601	621-604 (16)
VN1600E6F Vulcan 1600 Classic	2006	620-601	621-604 (16)
VN1600F6F-F7F Vulcan 1600	06-07	620-601	621-604 (16)
Mean Streak			

## Kawasaki ATV

Model	Year	Valve Stem Seal Pk/10	Valve Keeper Each
KLF110A1/A2 Mojave	87-88	620-603	621-602 (4)
KLF110B1/B2 Mojave	87-88	620-603	621-602 (4)
KLT110A1/A2/A3	84-86	620-603	621-602 (4)
KLT160A1	1985	620-603	621-602 (4)
KLF185A1/A2/A3/A4 Bayou	85-88	620-603	621-602 (4)
KLT185A1/A2 Bayou	85-86	620-603	621-602 (4)
KLT200A1/A2/A3/A4/A4A	81-83	620-601	621-604 (4)
KLT200B1	1983	620-601	621-604 (4)
KLT200C1/C2	83-84	620-601	621-604 (4)
KLF220A1-A15 Bayou 220	88-02	620-603	621-601 (4)
KLF250A1/A2/A3 Bayou 250	03-11	620-603	621-601 (4)
KLF250A6F-ABF Bayou 250	06-11	620-603	621-601 (4)
KLT250A1/A2	82-83	620-601	621-604 (4)
KLT250C1/C2/C3 Prairie	83-85	620-601	621-604 (4)
KLT250P1 Police	1984	620-601	621-604 (4)
KSF250A1-A17 Mojave 250	87-03	620-603	621-602 (8)
KSF250A18 KFX250 Mojave	2004	620-603	621-602 (8)
KEF300A1-A6 Lakota 300	95-00	620-601	621-604 (4)
KEF300B1/B2/B3 Lakota Sport	01-03	620-601	621-604 (4)
KLF300A1/A2 Bayou	86-87	620-601	621-604 (4)
KLF300B1-B17 Bayou 300	88-04	620-601	621-604 (4)
KLF300C1-C16 Bayou 300 4x4	89-04	620-601	621-604 (4)
KVF300A1-A Prairie 3004 x4	99-02	620-601	621-604 (4)
KVF300B1-B Prairie 300	99-02	620-601	621-604 (4)
KVF360A1/A2/A3 Prairie 360 4x4	03-05	620-601	621-604 (4)
KVF360A6F-ACF Prairie 360 4x4	06-12	620-601	621-604 (4)
KVF360B1-B9F Prairie 360	03-09	620-601	621-604 (4)
KVF360C1 Prairie 360 Advantage	2003	620-601	621-604 (4)
KLF400B1-B7 Bayou 400 4x4	93-99	620-603	621-603 (8)
KSF400A1/A2/A/A6F KFX400	03-06	620-404	—
KVF400A1/A2 Prairie 400 4x4	97-98	620-603	621-603 (8)
KVF400B1 Prairie 400	1998	620-603	621-603 (8)
KVF400C1/C2/C3/C4 400 4x4	99-02	620-603	621-603 (8)
KVF400D1-D5 Prairie 400	98-02	620-603	621-603 (8)
KVF650A1/A2 Prairie 650 4x4	02-03	620-604	621-605 (16)
KVF650B1/B2 Prairie 650 4x4	02-03	620-604	621-605 (16)
Advantage Classic			
KVF650D1Brute Force 650 4x4	2005	620-604	621-605 (16)
KVF650D6F-DCF Brute Force 650 4x4	06-12	620-604	621-605 (16)
KVF650E1 Brute Force 650 4x4	2005	620-604	621-605 (16)
Realtree Hardwoods Green HD			
KVF650E6F-E9F Brute Force 650 4x4	06-09	620-604	621-605 (16)
Realtree Hardwoods Green HD			
KVF650F6F-FCF Brute Force 650 4x4i	06-09	620-604	621-605 (16)
KSV700A1/A2/A6F KFX700 V-Force	04-06	620-604	621-605 (16)
KSV700B1/B2/B6F KFX700 V-Force	04-06	620-604	621-605 (16)
KSV700C6F	2006	620-604	621-605 (16)
KVF700A1/A2/A6F Prairie 700 4x4	04-06	620-604	621-605 (16)
KVF700B1/B2 Prairie 700 4x4	04-05	620-604	621-605 (16)
Hardwoods Green HD			
KVF700D1/D6F Prairie 700 4x4	05-06	620-604	621-605 (16)
Team Green Special Edition			
KVF750A1 Brute Force 750 4x4i	2005	620-604	621-605 (16)
KVF750A6F-A7F Brute Force 750 4x4i	06-07	620-604	621-605 (16)
KVF750B1 Brute Force 750 4x4i	2005	620-604	621-605 (16)
KVF750B6F-B7F Brute Force 750 4x4i	06-07	620-604	621-605 (16)
KVF750C6F-C9F Brute Force 750 4x4i	06-07	620-604	621-605 (16)



# Vesrah Valve Stem Seals & Valve Keepers

## Kawasaki Dual Sport & Offroad

Model	Year	Valve Stem Seal Pk/10	Valve Keeper Each
KLX110A1/A2/A3/A4	02-05	620-606	—
KLX110A6F-A9F	06-09	620-606	—
KLX110 CAF-CCF	10-12	620-606	—
KLX125A1/A2/A3	03-05	620-401	—
KLX125A6F	2006	620-401	—
KLX125B1/B2/B3	03-05	620-401	—
KLX125B6F	2006	620-401	—
KL250A1/A1A/A2 /A3/A4	78-81	620-601	621-604 (4)
KL250C1/C2	83-84	620-601	621-604 (4)
KL250D2-D22 KLR250 Dual Sport	85-05	620-603	621-603 (8)
KL250G4/G5/G6/G7 Super Sherpa	00-03	620-606	—
KLX250A1/A2	79-80	620-601	621-604 (4)
KLX250D2/D3/D4 KLX250R	94-96	620-606	—
KLX250H6F-H7F KLX250S Dual Sport	06-07	620-606	—
KLX250 T9F-TCF	09-12	620-606	—
KX250N1/N2 KX250F	04-05	620-606	—
KX250T6F-YCF	06-12	620-606	—
KLX300A2-A7F KLX300R	97-07	620-606	—
KLX300A6F-A7F KLX300R	06-07	620-606	—
KLX400A1 KLX400SR Dual Sport	2003	620-404	—
KLX400B1 KLX400R	2003	620-404	—
KX450D6F-EBF	06-11	620-603	621-603 (8)
KL600A1 KLR600	1984	620-601	621-604 (8)
KL600B1/B2 KLR600	85-86	620-601	621-604 (8)
KL650A1-A19 KLR650	87-05	620-601	621-604 (8)
KL650A6F-ECF KLR650	06-12	620-601	621-604 (8)
KL650B1/B2 Tengai KLR650	90-91	620-601	621-604 (8)
KLX650A1/A2/A3 KLX650R	93-95	620-601	621-604 (8)
KLX650C1/C2/C3/C4	93-96	620-601	621-604 (8)
KLX650D1 KLX650R	1996	620-601	621-604 (8)

## Suzuki Street

SP100D Dual Sport	1983	620-401	—
DR125SER/SES/SET Dual Sport	94-96	620-401	—
GN125Z/D	82-83	620-401	—
GN125EM/EN/EP/ER/ES/ET/EV	91-97	620-401	—
SP125Z/D Dual Sport	82-83	620-401	—
DR200SET-K9 Dual Sport	96-09	620-401	—
SP200G/H/J Dual Sport	86-88	620-401	—
DR250SL-SER Dual Sport	90-95	620-404	621-405 (8)
GN250Z/D	82-83	620-401	—
GN250F	1985	620-401	—
GN250J	1988	620-401	—
GS250TT/TX	80-81	620-401	—
GZ250Y/K1-L0 Marauder	99-10	620-401	—
SP250Z/D Dual Sport	82-83	620-401	—
SP250F Dual Sport	1985	620-401	—
GS300LZ/LD	82-83	620-401	—
GS300LF	1985	620-401	—
DR350SL-SEX Dual Sport	90-99	620-404	621-405 (8)
GN400T/TX/TZ	80-82	620-402	621-401 (4)
GN400XT/XX	80-81	620-402	621-401 (4)
GS400B/XB/X/XC	77-78	620-402	621-401 (8)
DR-Z400SY-SK6 Dual Sport	00-06	620-404	—
DR-Z400SM Supermotard	05-06	620-404	—
SP400T Dual Sport	1980	620-402	621-401 (4)
GS425N/EN/LN	1979	620-402	621-401 (8)
GS450ET/EX/EZ/ED	80-83	620-402	621-401 (8)
GS450GAZ/GAD Automatic	82-83	620-402	621-401 (8)
GS450GAF Automatic	1985	620-402 In	621-401 (4)
			621-401 (4)
GS450LT/LXLZ/LD	80-83	620-402	621-401 (8)
GS450LF/LG/LH/LG	85-88	620-402 In	621-401 (4)
			621-401 (4)
GS450ST/SX	80-81	620-402	621-401 (8)
GS450TX/TXZ/TXD	81-83	620-402	621-401 (8)
GS500EK-EY	89-00	620-402	621-401 (8)
GS500EK1/EK2	01-02	620-402	621-401 (8)

## Suzuki Street

Model	Year	Valve Stem Seal Pk/10	Valve Keeper Each
GS500FK4-L0	04-10	620-402	621-401 (8)
SP500X/Z/D	81-83	620-402	621-401 (4)
GS550B/C/EC/N/EN/ET	77-80	620-402	621-401 (16)
GS550ED/ESD	1983	620-403	621-405 (32)
GS550ES3/ESE/EF/ESF/ESG	83-86	620-403	621-405 (32)
GS550LN/LT/LX/LZ	79-82	620-402	621-401 (16)
GS550LD	1983	620-403	621-405 (32)
GS550LF/LG	85-86	620-403	621-405 (32)
GS550MZ Katana	1982	620-402	621-401 (16)
GS550TX	1981	620-402	621-401 (16)
GSF600ST/SV/SW/SX/SY Bandit	96-00	620-404	621-405 (32)
GSF600SK1/SK2/SK3 Bandit	01-03	620-404	621-405 (32)
GSX600FJ-FY Katana	88-00	620-404	621-405 (32)
GSX600FK1-L2 Katana	01-12	620-404	621-405 (32)
GSX-R600WN/WP	92-93	620-406	—
GSX-R600V/W/X/Y	97-00	620-406	—
GSX-R600K1-L2	01-12	620-406	—
RF600RR/RS/RT	94-96	620-406	—
SP600F Dual Sport	1985	620-402	621-401 (8)
DL650K4-L1 V-Storm	04-11	620-406	—
GR650D/XD Tempter	1983	620-402	—
DR650SL/SM/SN/SP/SER/SES	90-95	620-402	621-401 (8)
DR650SET-L1 Dual Sport	96-11	620-401	—
GS650EX/EZ	81-82	620-402	621-401 (16)
GS650GX/GZ/GD	81-83	620-402	621-401 (16)
GS650GLX/GLZ/GLD	81-83	620-402	621-401 (16)
GS650MD Katana	1983	620-402	621-401 (16)
LS650FFG/FFH Savage	86-87	620-402	—
LS650FPG/FPJ/FPJ Savage	86-88	620-402	—
LS650PS/PT/PV/PW/PX/PY Savage	95-00	620-402	—
LS650PK1/PK2/PK3/PK4 Savage	01-04	620-402	—
LS650 K5-L1 Boulevard S40	05-11	620-402	—
SV650X-L0	99-10	620-406	—
SV650SX-L0	99-10	620-406	—
SV650SA K7-L0	07-10	620-406	—
XN85D Turbo	1983	620-402	621-401 (16)
GS700EF/EFS	1985	620-401	—
GV700GLF/GLF2 Madura	1985	620-401	—
VS700GLFG/GLFH Intruder	86-87	620-401	—
VS700GLPG/GLPH Intruder	86-87	620-401	—
VS700GLEFG/GLEFH Intruder	86-87	620-401	—
VS700GLEPG/GLEPH Intruder	86-87	620-401	—
GS750B/C/N/EC/EN	77-79	620-402	621-401 (16)
GS750ET/EX/EZ	80-82	620-401	—
GS750ED/ESD	1983	620-401	—
GS750LN	1979	620-402	621-401 (16)
GS750LT/LX	80-81	620-401	—
GS750SD Katana	1983	620-401	—
GS750TZ/TD	82-83	620-401	—
GSX750FK-FK6 Katana	89-06	620-404	621-405 (32)
GSX-R750G/H	86-87	620-404	621-405 (32)
GSX-R750RG	1986	620-404	621-405 (32)
GSX-R750J/K/L/N/M	88-92	620-404	621-405 (32)
GSX-R750WP/WR/WS	93-95	620-406	—
GSX-R750TN/W/X/Y	96-99	620-406	—
GSX-R750 K4-L1	04-12	620-406	—
VS750GLPJ-GLPM Intruder	88-91	620-401	—
VL800K1/K2/K3/K4 Volusia	01-04	620-401	—
VL800 K5-L1 Boulevard C50	05-11	620-401	—
VL800 K5-L1 Boulevard C50T	05-11	620-401	—
VL800Z Boulevard C50 Limited	05-06	620-401	—
VS800GLN-GLK4 Intruder	92-04	620-401	—
VS800 K5-K9 Boulevard S50	05-09	620-401	—
VX800L/M/N/P	90-93	620-401	—
VZ800V-K4 Marauder	97-04	620-401	—
GS850GN/GT/GX/GZ/GD	79-83	620-402	621-401 (16)
GS850GLT/GLX/GLZ/GLD	80-83	620-402	621-401 (16)



VINTAGE  
INTAKE  
ENGINE  
SUSPENSION  
CONTROL  
ELECTRICAL  
CHEMICAL  
TOOLS  
WATERCRAFT

# Vesrah Valve Stem Seals & Valve Keepers

## Suzuki Street

Model	Year	Valve Stem Seal Pk/10	Valve Keeper Each
RF900RR/RS/RT/RV	94-97	620-406	—
RF900RZS	1995	620-406	—
DL1000K2-K9 V-Storm	02-09	620-401	—
GS1000C/EC/N	78-79	620-402	621-401 (16)
GS1000EN/ET	79-80	620-402	621-401 (16)
GS1000GT/GLT/GX/GLX	80-81	620-402	621-401 (16)
GS1000LN	1979	620-402	621-401 (16)
GS1000SN	1979	620-402	621-401 (16)
GS1000SZ Katana	1982	620-401	—
GSX-R1000K5-K6	05-06	620-406	—
SV1000K3-K7	03-07	620-401	—
SV1000SK3-K7	03-07	620-401	—
TL1000SV/SW/SX/SY/SK1	97-01	620-401	—
TL1000RW/RXRY/RK1/RK2/RK3	98-03	620-401	—
GS1100ET/EX/EZ	80-82	620-401	—
GS1100ED/ESD	1983	620-401	—
GS1100GZ/GLZ/GD/GLD	82-83	620-402	621-401 (16)
GS1100GKZ~GKE	82-84	620-402	621-401 (16)
GS1100LT	1980	620-401	—
GS1100SD Katana	1983	620-401	—
GSX-R1100G/H/J/K/L/M/N	86-92	620-404	621-405 (32)
GSX-R1100WP-VWV	93-98	620-406	—
GSX1100FJ-FP Katana	88-93	620-404	621-405 (32)
GSX1100GM/GN/GP Shaft	91-93	620-404	621-405 (32)
GS1150ES3/ESE/ESF	83-85	620-401	—
GS1150EF/EF2/EG/ESG	85-86	620-401	—
GSF1200SV/SAV/SW/SX/SY Bandit	97-00	620-404	621-405 (32)
GSF1200SK1-K2 Bandit	01-02	620-404	621-405 (32)
GV1200GLF/GLF2/GLG Madura	85-86	620-401	—
GSX1300RX-L1 Hayabusa	99-11	620-404	—
GV1400GCG/GCH Cavalcade	86-87	620-403	621-405 (32)
GV1400GDG/GDH/GDJ Cavalcade	86-88	620-403	621-405 (32)
GV1400GTG/GTH Cavalcade	86-87	620-403	621-405 (32)
VS1400GLFH-GLFN Intruder	87-92	620-401 In	—
		620-402 Ex	—
VS1400GLPH-GLPK4 Intruder	87-04	620-401 In	—
		620-402 Ex	—
VS1400 K5-K8 Boulevard S83	05-08	620-401 In	—
		620-402 Ex	—
VL1500W/X/Y Intruder 1500 LC	98-00	620-401 In	—
		620-402 Ex	—
VL1500K1/K2/K3/K4 Marauder	01-04	620-401 In	—
		620-402 Ex	—
VL1500 Boulevard C90	05-10	620-401 In	—
		620-402 Ex	—
VL1500 Boulevard C90T	05-09	620-401 In	—
		620-402 Ex	—
VZ1600K4 Marauder	2004	620-601	621-604 (16)
VZ1600 Boulverad M95	05-06	620-601	621-604 (16)

## Suzuki ATV

ALT125D/E/F/G	83-86	620-401	—
LT125D/E/F/G/H Quadrunner	83-87	620-401	—
LT160K3/K4 Quadrunner	03-04	620-401	—
LT160EK/EL/EM/EN	89-92	620-401	—
LT-F160M/N/P/R/S	91-95	620-401	—
LT-F160T/V/W/X/Y/K1	96-01	620-401	—
LT-F160K3	2003	620-401	—
ALT185E/F	84-85	620-401	—
LT185E/F/G/H	84-87	620-401	—
LT230EH/EJ/EK/EL Quadrunner	87-90	620-401	—
LT230EM/EN/EP Quadrunner	91-93	620-401	—
LT230GEF/GEG Quadrunner	85-86	620-401	—
LT230SF/SG/SH/SJ Quadsport	85-88	620-401	—
LT-F230G/H	86-87	620-401	—
DR-Z250K1-K7	01-07	620-406	—
LT250EFF/EFQ Quadrunner	85-86	620-401	—
LT250SK/SL	89-90	620-401	—
RM-Z250K7-L2	07-12	620-406	—

## Suzuki ATV

Model	Year	Valve Stem Seal Pk/10	Valve Keeper Each
LT-4WDP/WDR/WDS Quad 4x4	93-95	620-401	—
LT-4WDT/WDV/WDW Quad 4x4	96-98	620-401	—
LT-F250J/K/L/M/N/P	88-93	620-401	—
LT-F250R/S/T/V/W/X/Y/K1	94-01	620-401	—
LT-F250K2-L2 Ozark	02-12	620-401	—
LT-F250FX/FY/FK1/FK2	99-02	620-401	—
LT-Z250K4-K9 Quadsport	04-09	620-401	—
LT-F250F X-L1 Quadrunner	99-02	620-401	—
LT300EH/EJ/EK Quadrunner	87-89	620-401	—
LT-F300FX/FY/K1/K2 King Quad	99-02	620-401	—
LT-F4WDXM/N/P/R King Quad	91-94	620-401	—
LT-F4WDXS/T/V/W King Quad	95-98	620-401	—
LT-400K2/K3 Eiger 2WD	02-03	620-404	621-405 (8)
LT-A400FK2/FK3 Eiger Auto 4WD	02-03	620-404	621-405 (8)
LT-A400FK4/FK7 Eiger Auto 4WD	04-07	620-404	621-405 (8)
LT-A400FK3 Eiger Auto 4WD	2003	620-404	621-405 (8)
LT-A400FK4 Eiger Auto 4WD	2004	620-404	621-405 (8)
LT-A400K2/K3/K4 Eiger Auto 2WD	02-04	620-404	621-405 (8)
LT-F400FK2-FK7 Eiger 4WD	02-07	620-404	621-405 (8)
LT-F400K2-K8 Eiger 2WD	02-08	620-404	621-405 (8)
LT-Z400K3-L2 Z400 Quadsport	03-12	620-404	—
LT-A500FY/FK1 Quadmaster	00-01	620-404	621-405 (8)
LT-A500FK2/FK3 Vinson 4WD	02-03	620-404	621-405 (8)
LT-A500FK4/FCK4 Vinson 4WD	2004	620-404	621-405 (8)
LT-A500FK5-K7 Vinson 4WD	05-K7	620-404	621-405 (8)
LT-F500FK3-FK7 Vinson Manual 4WD	03-07	620-404	621-405 (8)
LT-F500FW-L1 Quadrunner	98-11	620-404	621-405 (8)
LT-A700XK5 King Quad	2005	620-401	—
LT-V700FK4/FK5 Twin Peaks	04-05	620-604	621-605 (16)

## Suzuki Dual Sport & Offroad

DR100D/E/F/G/H/J/K/L	83-90	620-401	—
SP100D Dual Sport	1983	620-401	—
DR125Z/D/E	82-84	620-401	—
DR125G/H/J	86-88	620-401	—
DR125SER/SES/SET Dual Sport	94-96	620-401	—
DR-Z125K3-K9	03-09	620-401	—
DR-Z125LK3-K9	03-05	620-401	—
SP125Z/D Dual Sport	82-83	620-401	—
SP125G/H/J Dual Sport	86-88	620-401	—
DR200SET-K9 Dual Sport	96-09	620-401	—
SP200G/H/J Dual Sport	86-88	620-401	—
DR250Z/D	82-83	620-401	—
DR250F	1985	620-401	—
DR250SL-SES Dual Sport	90-95	620-404	621-405 (8)
DR250L/M/N/P	90-93	620-404	621-405 (8)
RM-Z250K4-L2	04-12	620-606	—
SP250Z/D Dual Sport	82-83	620-401	—
SP250F Dual Sport	1985	620-401	—
DR350L/M/N/P/R/S/T/V/W/X	90-99	620-404	621-405 (8)
DR350SL-SEX Dual Sport	90-99	620-404	621-405 (8)
DR370C/N	78-79	620-402	621-401 (4)
SP370C/N Dual Sport	78-79	620-402	621-401 (4)
DR400T	1980	620-402	621-401 (4)
DR-Z400Y/K1/K2/K3/K4	00-04	620-404	—
DR-Z400EY-K7	00-07	620-404	—
DR-Z400SY-K2 Dual Sport	00-12	620-404	—
DR-Z400SM Supermoto	2005	620-404	—
SP400T Dual Sport	1980	620-402	621-401 (4)
RM-Z450K5-K7	05-07	620-404	—
RM-Z450Z L0-L1	10-12	620-401	—
DR500X/Z/D	81-83	620-402	621-401 (8)
SP500X/Z/D Dual Sport	81-83	620-402	621-401 (8)
SP600F Dual Sport	1985	620-402	621-401 (8)
DR650SL/SM/SN/SP/SER/SES	90-95	620-402	621-401 (8)
DR650SET-L1 Dual Sport	96-11	620-401	—

# Vesrah Valve Stem Seals & Valve Keepers

## Yamaha Street

Model	Year	Valve Stem Seal Pk/10	Valve Keeper Each
XT125J/K/KC Dual Sport	82-83	620-203	621-201 (4)
SR185H/J Exciter	81-82	620-203	621-201 (4)
TW200T/TC-B1 Trailway	87-12	620-203	621-201 (4)
XT200J/K/KC Dual Sport	82-83	620-203	621-201 (4)
XT225D/DC-B1 Serrow	92-12	620-203	621-201 (4)
SR250G/H/J Exciter	80-82	620-201	_____
SR250TH Exciter	1981	620-201	_____
SRX250T/TC	1987	620-204	_____
XT250G/H/J/K/KC Dual	80-83	620-201	_____
XT250L/LC Dual Sport	1984	620-204	_____
XV250U/UC/W/WC/A/AC	88-90	620-206	_____
XV250G/GC-K/KC Route 66	95-98	620-206	_____
XV250L/LC Virago 250	1999	620-206	_____
XV250P/PC/R/RC Virago 250	02-03	620-206	_____
XV250S/SC/T/TC Virago 250	04-05	620-206	_____
XV250V/V/C Virago 250	2006	620-206	_____
XT350N/NC-M/MC Dual Sport	85-00	620-204	_____
XS360C/D	76-77	620-201	_____
FZR400U/SUC/W/SWC/A/SAC	88-90	620-207	_____
XS400D/E/2E/F/2F	77-79	620-201	_____
XS4002E/2F	78-79	620-201	_____
XS400G/H Special II	80-81	620-201	_____
XS400J/K Maxim	82-83	620-201	_____
XS400R/RJ/RK Seca	82-83	620-201	_____
XS400SG/SH Special	80-81	620-201	_____
XS400SJ Heritage Special	1982	620-201	_____
SR500E/F/G/H	78-81	620-202	_____
TX500/A	73-74	620-204	_____
XS500B/C/D/E	75-78	620-204	_____
XT500C/D/E/F/G/H Dual Sport	76-81	620-202	_____
XV500K Virago	1983	620-201	_____
XV535T/TC/U/UC Virago	87-88	620-201	_____
XV535A/AC Virago	1990	620-201	_____
XV535E/EC-M/MC Virago	93-00	620-201	_____
XV535SF/SFC-SJ/SJC Virago	94-97	620-201	_____
XJ550H/J/K Maxim	81-83	620-203	621-201 (16)
XJ550RH/RJ/RK Seca	81-83	620-203	621-201 (16)
XT550J/K Dual Sport	82-83	620-201	_____
XZ550R/RK Vision	82-83	620-204	621-201 (16)
FJ600L/LC/N/NC	84-85	620-203	621-201 (16)
FZ600S/SC/T/TC/U/UC	86-88	620-203	621-201 (16)
FZR600W/WC/AC	89-90	620-207	_____
FZR600RA/RAC-RK/RKC	90-99	620-207	_____
SRX600S/SC	1986	620-201	_____
XJ600SD/SDC-SK/SKC Seca II	92-98	620-205	_____
XT600L/LC-EG/EGC Dual Sport	84-95	620-201	_____
YX600S/SC-A/AC Radian	86-90	620-204	621-201 (16)
YZF-R6SN/SNC Champion Limited	2001	_____	_____
XJ650G/H/J/K Maxim	80-83	620-201	_____
XJ650LH Midnight Maxim	1981	620-201	_____
XJ650LJ/LK Seca Turbo	82-83	620-201	_____
XJ650RJ Seca	1982	620-201	_____
XS1/XS1B/XS2-650	70-72	620-202	_____
TX650/A	73-74	620-202	_____
XS650B/C/D/E/F/2F	75-79	620-202	_____
XS650G/H Special II	80-81	620-202	_____
XS650SE/SF/SG Special	78-80	620-202	_____
XS650SH/SJ/SK Heritage Special	81-83	620-202	_____
XVS650AK/AKC-AV/AVC	98-06	620-201	_____
V-Star Classic			
XVS650ATR/ATRC-ATV/ATVC	03-06	620-201	_____
V-Star Silverado			
XVS650ATS V-Star Silverado	2004	620-201	_____
XVS650ATT/ATTC V-Star Silverado	2005	620-201	_____
XVS650K/KC-T/TC V-Star Custom	98-05	620-201	_____
FZ700T/TC	1987	620-205	_____
FZX700S/SC/T/TC Fazer	86-87	620-205	_____
XJ700N/NC/S/SC Maxim	85-86	620-201	_____
XJ700XN/XNC/XS/XSC Maxim	85-86	620-201	_____
XV700L/LC/N/NC Virago	84-85	620-202	_____
XV700CS/CSC/CT/CTC Virago	86-87	620-202	_____
XV700SS/SSC Virago	1986	620-202	_____

## Yamaha Street

Model	Year	Valve Stem Seal Pk/10	Valve Keeper Each
FZ750N/S/SC	85-86	620-205	_____
FZ750U/UC	1988	620-205	_____
FZR750RT/RU	87-88	620-205	_____
TX750/A	73-74	620-201	_____
XJ750J/K Maxim	82-83	620-201	_____
XJ750MK Midnight Maxim	1983	620-201	_____
XJ750RH/RJ/RK Seca	81-83	620-201	_____
XS750D/2D/E/F	77-79	620-201	_____
XS750SE/SF Special	78-79	620-201	_____
XV750H/J/K Virago	81-83	620-202	_____
XV750MK Midnight Virago	1983	620-202	_____
XV750U/UC-H/HC Virago	88-96	620-201	_____
XV750H1/H1C/J1/J1C Virago	96-97	620-201	_____
YZF750RF/RFC	1994	620-207	_____
YZF750RH/RHC/RJ/RJC/RK/RKC	96-98	620-207	_____
TDM850D/DC/E/EC	92-93	620-204	_____
XS850G/H	80-81	620-201	_____
XS850LG/LH Midnight Special	80-81	620-201	_____
XS850SG/SH Special	80-81	620-201	_____
XJ900RK Seca	1983	620-201	_____
XV920J/K Virago	82-83	620-202	_____
XV920MK Midnight Virago	1983	620-202	_____
FZS1000N/NC/P/PC/R/RC FZ1	01-03	_____	_____
FZS1000S/SC/T/TC FZ1	04-05	_____	_____
FZS1000SPR/SPRC FZ1	2003	_____	_____
FZR1000T/TC/U/UC	87-88	620-205	_____
FZR1000W/WC-G/GC	89-95	620-207	_____
GTS1000AE/AEC/AF/AFC	93-94	620-207	_____
XV1000L/LC/N/NC Virago	84-85	620-202	_____
YZF1000R/RJC	1997	_____	_____
YZF1000RK/RKC	1998	_____	_____
YZF-R1L/LC/MMC/N/NC/P/PC R1	99-02	_____	_____
YZF-R1R/RC/S/SC/T/TC/VZ R1	03-06	_____	_____
YZF-R1SN/SNC Champions LTD.ED	2001	_____	_____
FJ1100L/LC/N/NC	84-85	620-204	_____
XJ1100J Maxim	1982	620-201	_____
XS1100E/F/G/H	78-81	620-201	_____
XS1100LG/LH Midnight Special	80-81	620-201	_____
XS1100SF/SG/SH Special	79-81	620-201	_____
XV1100S/SC-L/LC Virago	86-99	620-202	_____
XV1100SH/SHC/SJ/SJC Virago	96-97	620-202	_____
XV1100SK/SKC Virago	1998	620-202	_____
XVS1100AM/AMC-AS/ASC	00-04	620-202	_____
V-Star 1100 Classic			
XVS1100ATR/ATRC-ATV/ATVC	03-06	620-202	_____
V-Star 1100 Silverado			
XVS1100AWR/AWRC-AWV/VC	03-06	620-202	_____
V-Star 1100 Classic			
XVS1100L/LC-T/TC	99-05	620-202	_____
V-Star 1100 Custom			
FJ1200S/SC/T/TC	86-87	620-204	_____
FJ1200W/WC/A/AC/B/BC/D/DC	89-92	620-204	_____
FJ1200AD/ADC/AE/AEC (ABS)	92-93	620-204	_____
VMX12N/NC/S/SC V-Max	85-86	620-204	_____
VMX12U/UC-V/VC V-Max	88-06	620-204	_____
XVZ12TK/L/KC2 Venture	83-84	_____	621-201 (32)
XVZ12TDK Venture Royale	1983	_____	621-201 (32)
XVZ12DL/DKC2/DN Venture Royale	84-85	_____	621-201 (32)
FJ1300R	03-12	620-205	_____
FJ1300AS ABS	04-12	620-205	_____
XVZ13DS/DSC-DE/DEC	86-93	_____	621-201 (32)
Venture Royale			
XVZ13T/TC/U/UC Venture	87-88	_____	621-201 (32)
XVZ13AH/AHC-AM/AMC Royal Star	96-00	_____	621-201 (16)
XVZ13AT Royal Star Tour Classic	96-00	_____	621-201 (16)
XVZ13LT Royal Star Tour Deluxe	97-01	_____	621-201 (16)
XVZ13TF Royal Star Venture	99-01	_____	621-201 (16)
XVZ13TFS Venture Limited Edition	2000	_____	621-201 (16)

# Vesrah Valve Stem Seals & Valve Keepers

## Yamaha ATV

Model	Year	Valve Stem Seal Pk/10	Valve Keeper Each
YFM50 S-X Raptor 50	04-08	620-206	_____
YFM80GT/GV/GHV Grizzly 80	05-06	620-206	_____
YFM80N/S/T/U/W/A/B/D/G Moto-4	85-95	620-206	_____
YFM80H/J/K/L/M/MC/N/NC Badger	96-01	620-206	_____
YFM80WP/WR/WS Raptor	02-04	620-206	_____
YFM80R T-X Raptor	05-08	620-206	_____
YFM100T/U/W/A/B Champ	87-91	620-206	_____
YFA1W Breeze	1989	620-206	_____
YFA1B/D/E/F/G/H/J/K/L Breeze	91-00	620-206	_____
YFA1M/MC/N/NC/P/PC Breeze	00-02	620-206	_____
YFA1R/RC/S/SC Breeze	03-04	620-206	_____
YFM125S-B Grizzly	04-12	620-206	_____
YFM125GHT-X Grizzly 125 Hunter	05-08	620-206	_____
YFM125GHV Grizzly 125 Hunter	2006	620-206	_____
YFM200DXS/DXT/DXU/DXW Moto-4	86-89	620-203	621-201 (4)
YFM200N Moto-4	1985	620-203	621-201 (4)
YTM200K/L/N Tri-Moto	83-85	620-203	621-201 (4)
YTM200EK/EL Tri-Moto	83-84	620-203	621-201 (4)
YTM200ERN Tri-Moto	1985	620-203	621-201 (4)
YFM225S/T/U Moto-4	86-88	620-203	621-201 (4)
YTM225DRN/DRS Tri-Moto	85-86	620-203	621-201 (4)
YTM225DXK/DXL/DXN Tri-Moto	83-85	620-203	621-201 (4)
YFB250D/E/F/G Timberwolf 2WD	92-95	620-203	621-201 (4)
YFB250H/J Timberwolf 2WD	96-97	620-203	621-201 (4)
YFB250FWF-FWM Timberwolf 4WD	94-00	620-203	621-201 (4)
YFB250UH/UJ/UK Timberwolf 2WD	96-98	620-203	621-201 (4)
YFM250BT/BV Bruin 250	05-06	620-203	621-201 (4)
YFM250W/A/B Moto-4	89-91	620-203	621-201 (4)
YFM250XL/XLC Beartracker 2WD	1999	620-203	621-201 (4)
YFM250XM/XMC Beartracker 2WD	2000	620-203	621-201 (4)
YFM250XHN Beartracker Real Tree	2001	620-203	621-201 (4)
YFM250XHP Beartracker Real Tree	2002	620-203	621-201 (4)
YFM250XN/XP/XR/XS Beartracker	01-04	620-203	621-201 (4)
YFM350S Raptor	2004	620-201	_____
YFM350RSET/RESV Raptor 350 SE	05-06	620-201	_____
YFM350RT-Y Raptor	05-09	620-201	_____
YFM350ERT-ERA Moto-4	87-90	620-201	_____
YFM350ERD-ERG Moto-4	92-95	620-201	_____
YFM350FAS Bruin 350 Auto 4x4	2004	620-201	_____
YFM350FAHS Bruin 350 Auto 4x4	2004	620-201	_____
Hardwood Camo			
YFM350FHL/FHLC Wolverine	1999	620-201	_____
YFM350FWT-FWJ Big Bear	87-97	620-201	_____
YFM350FWBJ/K/KC/L/LC Big Bear	97-99	620-201	_____
YFM350FXG-FXR Wolverine	95-03	620-201	_____
YFM350UH-UL Big Bear	96-99	620-201	_____
YFM350XT-XS Warrior	87-04	620-201	_____
YFM350AS Bruin 350 Auto 2WD	2004	620-201	_____
YFM350BAT/BAV Bruin 2WD	05-06	620-201	_____
YFM350FAS/FAT/FAV	04-06	620-201	_____
Bruin 350 Auto 4WD			
YFU1W/TW Prohauer	1989	620-204	621-201 (4)
YFM400S Big Bear 400 2WD	2004	620-201	_____
YFM400P Big Bear 400 2WD	2002	620-201	_____
YFM400AM/AMC Kodiak2WD	2000	620-201	_____

## Yamaha Dual Sport & Offroad

YFM400AR Kodiak4WD	2003	620-201	_____
YFM400FM/FMC Big Bear 4WD	2000	620-201	_____
YFM400FP Big Bear 4WD	2001	620-201	_____
YFM400FAM/FAMC/N/P/R/RB	00-03	620-201	_____
YFM400FAHM/MC/N/NC Kodiak	00-01	620-201	_____
YFM400FHP Big Bear 400 4WD	2002	620-201	_____
YFM400FHAP Kodiak 4x4 Hunter	2002	620-201	_____
YFM400FWE-FWL/FWLC Kodiak	93-90	620-201	_____
YFM400FWR Big Bear	2003	620-201	_____
YFM400FWAHM/MC Kodiak 4WD	2000	620-201	_____
YFM400FWNM/MC/N Big Bear 4WD	00-01	620-201	_____
YFM400FWNHM/MC/N Big Bear	00-01	620-201	_____
YFM400HP Big Bear 2WD	2002	620-201	_____
YFM400NM/MC/N Big Bear 2WD	00-01	620-201	_____
YFM400NR Big Bear 2WD	2003	620-201	_____
YFM400NHN Big Bear 2WD	2001	620-201	_____
YFM400FAS/T/FV Kodiak 400 4x4	04-06	620-201	_____
YFM400FAHS/T/V Kodiak 400 4x4	04-06	620-201	_____

## Yamaha Dual Sport & Offroad

Model	Year	Valve Stem Seal Pk/10	Valve Keeper Each
YFM450FAR/FARB Kodiak 4WD	2003	620-201	_____
YFM450FAS/FAT/FAV Kodiak 450	04-06	620-201	_____
YFM450FAHS/T/V Kodiak 450	04-06	620-201	_____
YFM450FXV Wolverine 450 4x4	2006	620-201	_____
YFZ450S/T/V	04-06	620-205 Ex	_____
YFM600FWAK/FWAKC Grizzly	1998	620-201	_____
YFM600FWAL/FWALC Grizzly	1999	620-201	_____
YFM600FWAM/FWAMC Grizzly	2000	620-201	_____
YFM600FVHM/FVHMC	2000	620-201	_____
YFM600FHN Grizzly Realtree Hunter	2001	620-201	_____
YFM600FN Grizzly	2001	620-201	_____
YFM660FAT/FAV Grizzly 660	05-06	620-203	621-201 (10)
YFM660FAHT/FAHV Grizzly 660	05-06	620-203	621-201 (10)
YFM660FAHWT	2005	620-203	621-201 (10)
YFM660FASET/FASEV Grizzly 660	05-06	620-203	621-201 (10)
YFM660FAP Grizzly	2002	620-203	621-201 (10)
YFM660FHAP Grizzly Hunter	2002	620-203	621-201 (10)
YFM660FHP Grizzly	2002	620-203	621-201 (10)
YFM660FHR-HD	2003	620-203	621-201 (10)
YFM660FHR-W	2003	620-203	621-201 (10)
YFM660FHRWL Grizzly WH	2003	620-203	621-201 (10)
YFM660FHRH Grizzly	2003	620-203	621-201 (10)
YFM660FHS Grizzly 660	2004	620-203	621-201 (10)
YFM660FHSWL Grizzly	2004	620-203	621-201 (10)
YFM660FLES Grizzly 660 Auto 4x4	2004	620-203	621-201 (10)
YFM660FP/FR/FS Grizzly 660	02-04	620-203	621-201 (10)
YFM660FSAF Grizzly Silver	2002	620-203	621-201 (10)
YFM660FRGY Grizzly	2003	620-203	621-201 (10)
YFM660RSET Raptor 660 SE	01-03	620-203	621-201 (10)
YFM660RN/RNC/RP/RPB Raptor	01-02	620-203	621-201 (10)
YFM660RR/RRB/RRC Raptor 660R	2003	620-203	621-201 (10)
YFM660RR/RS/RT Raptor 660	03-05	620-203	621-201 (10)
YFM660RLER/RLS Raptor 660R	03-04	620-203	621-201 (10)
YFM700RV Raptor	2006	620-203	621-201 (10)
TT-R90M/MC-W	00-07	620-207	_____
TT-R125M/MC/N/P/R/S	00-02	620-206	_____
TT-R125ER/ES/ET/EV (electric start)	03-06	620-206	_____
TT-R125LN/LPC/LR/LER/LS/LES	01-04	620-206	_____
TT-R125L M-V	05-09	620-206	_____
TT-R125LWM	2000	620-206	_____
XT125J/K/KC Dual Sport	82-83	620-203	621-201 (4)
BW200N/S Big Wheel	85-86	620-203	621-201 (4)
BW200ES/ET/EU Big Wheel	86-88	620-203	621-201 (4)
TW200T/TC-B1 Trailway	87-12	620-203	621-201 (4)
XT200J/K/KC Dual Sport	82-83	620-203	621-201 (4)
TT225S/T	86-87	620-203	621-201 (4)
TT225L/LC/RM/RMC	99-00	620-203	621-201 (4)
TT-R225N/NC/P/PC/R/RC/S	01-04	620-203	621-201 (4)
XT225D/DC-W/WC Serrow	92-07	620-203	621-201 (4)
TTR-230T/TC-B	05-12	620-203	621-201 (4)
TT250G/H/J	80-82	620-201	_____
TT250RL/RLC/RM/RMC	99-00	620-205	_____
TT-R250L/LC/M/MC	99-00	620-205	_____
TT-R250N/NC/P/PC/R/RC/S/SC	01-04	620-205	_____
TT-R250T/TC/V/Vc	05-06	620-205	_____
XT250G/H/J/K/KC Dual	80-83	620-201	_____
XT250L/LC Dual Sport	1984	620-204	_____
BW350T/U Big Wheel	87-88	620-201	_____
TT350S/T	86-87	620-204	_____
XT350N/NC-M/MC Dual Sport	85-00	620-204	_____
WR400FK/FL/FM	98-00	620-205 Ex	_____
YZ400FK/FL	98-99	620-205 Ex	_____
WR426FN/FP	01-02	620-205 Ex	_____
YZ426FM/FN/FP	00-02	620-205 Ex	_____
WR450F S-A	03-11	620-205 Ex	_____
YZ450F R-Y	03-09	620-205 Ex	_____
TT500C/D/E/F/G/H	76-81	620-202	_____
XT500C/D/E/F/G/H Dual Sport	76-81	620-202	_____
XT550J/K Dual Sport	82-83	620-201	_____
TT600K/L/N/S	83-86	620-201	_____
XT600L/LC-EG/EGC Dual Sport	84-95	620-201	_____



## Sudco Part Number to OEM Cross Reference Valve Stem Keepers

### Honda

OEM Reference	Vesrah Ref.	Order No.
14781-107-003	CC-1002	621-001
14781-MB4-000	CC-1003	621-003
14781-MA6-000	CC-1001	621-002
14781-HA5-003	CC-1003	621-003

### Kawasaki

12011-002	CC-4006	621-606
12011-003	CC-4001	621-601
12011-004	CC-4002	621-604
12011-1002	CC-4003	621-602
12011-1003	CC-4004	621-603
12011-1051	CC-4005	621-605

### Suzuki

12932-27A00	CC-3005	621-405
12932-45010	CC-3001	621-401

### Yamaha

4G0-12118-00-00	CC-2001	621-201
-----------------	---------	---------

## Valve Stem Seals

### Honda

OEM Reference	Vesrah Ref.	Order No.
12208-413-003	VS-1006	620-006
12208-MC0-003	VS-1006	620-006
12209-GB0-911	VS-1002	620-009
12209-GB0-912	VS-1002	620-009
12209-GB4-681	VS-1013	620-010
12209-GB4-682	VS-1013	620-010
12209-KE8-003	VS-1013	620-010
12209-KE8-005	VS-1013	620-010
12209-KL4-003	VS-1006	620-006
12209-MA6-003	VS-1013	620-010
12209-MA6-005	VS-1013	620-010
12209-MB9-003	VS-1007	620-005
12209-MC8-005	VS-1007	620-005
12209-ML0-721	VS-1014	620-014
12209-ML0-722	VS-1014	620-014
12209-MN1-671	VS-1007	620-005
12209-MZ5-003	VS-1014	620-014
12209-107-760	VS-1002	620-009

## Valve Stem Seals (cont.)

### Honda

OEM Reference	Vesrah Ref.	Order No.
12209-300-003	VS-1003	620-002
12209-413-003	VS-1012	620-012
12209-422-005	VS-1006	620-006
12209-428-003	VS-1006	620-006
12209-429-005	VS-1007	620-005
12212-MR5-671	VS-1007	620-005
14730-028-013	VS-1001	620-001
14730-028-013	VS-1001	620-001

### Kawasaki

92049-016	VS-4001	620-601
92049-1062	VS-4003	620-603
92049-1153	VS-4002	620-602
92049-1218	VS-4004	620-604
92049-1349	VS-4006	620-606
92049-S021	VS-3002	620-401
92049-S006	VS-3004	620-404

### Suzuki

09289-05003	VS-3002	620-401
09289-05008	VS-3003	620-403
09289-05010	VS-3004	620-404
09289-05011	VS-3004	620-404
09289-05015	VS-3002	620-401
09289-07002	VS-3001	620-402

### Yamaha

1J7-12119-01-00	VS-2001	620-201
1L9-12119-00-00	VS-2001	620-201
1WG-12119-00-00	VS-2007	620-207
2HX-12119-00-00	VS-2006	620-206
22F-12119-01-00	VS-2006	620-206
30X-12119-00-00	VS-2004	620-204
33M-12119-00-00	VS-2005	620-205
341-12119-02-00	VS-2002	620-202
4G0-12119-00-00	VS-2003	620-203
5H0-12119-00-00	VS-2003	620-203
5Y1-12119-00-00	VS-2004	620-204
M01-12129-00-00	VS-2001	620-201

# ATV & Offroad Engine Oil Seal Kits

## Engine Oil Seal Kits

ATV and Offroad motorcycle engine oil seal kits for a complete engine rebuild. Available for 2-stroke and 4-stroke applications.

### Honda ATV

Model	Year	K&S No.	Order No.
ATC250ES Big Red	85-87	50-1045	<b>504-009</b>
ATC250R	85-86	50-1001	<b>504-011</b>
ATC250SX	85-87	50-1045	<b>504-009</b>
TRX250 Four Trax 250	85-87	50-1045	<b>504-009</b>
TRX250R Four Trax 250R	86-89	50-1001	<b>504-011</b>
TRX250X Four Trax 250X	87-88	50-1044	<b>504-008</b>
TRX250X Four Trax 250X	91-92	50-1044	<b>504-008</b>
TRX300 Four Trax 300	88-00	50-1042	<b>504-007</b>
TRX300EX Four Trax 300EX	93-00	50-1043	<b>504-010</b>
TRX300EX Sport Trax 300EX	01-05	50-1043	<b>504-010</b>
TRX300FW Four Trax 300	1988	50-1041	<b>504-006</b>
TRX300FW Four Trax 300	90-00	50-1041	<b>504-006</b>
TRX400EX Four Trax 400E	99-00	50-1046	<b>504-070</b>
TRX400EX Sport Trax 400EX	01-08	50-1046	<b>504-070</b>

### Honda Offroad

CRF50F	04-09	51-1048	<b>504-082</b>
XR50R	00-03	51-1048	<b>504-082</b>
Z50R	79-89	51-1048	<b>504-082</b>
Z50R	91-99	51-1048	<b>504-082</b>
Z50RD	1986	51-1048	<b>504-082</b>
CR60R	83-84	51-1003	<b>504-075</b>
CRF70F	04-09	51-1048	<b>504-082</b>
XR70R	97-03	51-1048	<b>504-082</b>
CR80R	86-02	51-1003	<b>504-075</b>
CR80RB	00-02	51-1003	<b>504-075</b>
CRF80F	04-09	51-1046	<b>504-080</b>
XR80	79-84	51-1046	<b>504-080</b>
XR80R	85-88	51-1046	<b>504-080</b>
XR80R	90-91	51-1046	<b>504-080</b>
XR80R	93-03	51-1046	<b>504-080</b>
CR85R	03-07	51-1003	<b>504-075</b>
CR85RB	03-07	51-1003	<b>504-075</b>
CRF100F	04-09	51-1043	<b>504-017</b>
XR100	81-84	51-1043	<b>504-017</b>
XR100R	85-03	51-1043	<b>504-017</b>
CR125R	87-03	51-1001	<b>504-012</b>
XR185	1979	51-1044	<b>504-018</b>
TLR200	86-87	51-1044	<b>504-018</b>
XR200	80-84	51-1044	<b>504-018</b>
XR200R	81-83	51-1044	<b>504-018</b>
XR200R	1985	51-1045	<b>504-019</b>
XR200R	86-02	51-1044	<b>504-018</b>
CR250R	88-07	51-1002	<b>504-013</b>
XR250L	91-96	51-1045	<b>504-019</b>
XR250R	86-04	51-1045	<b>504-019</b>
XR400R	96-04	51-1041	<b>504-015</b>
CRF450R	02-05	51-1047	<b>504-081</b>
CR500R	88-01	51-1002	<b>504-013</b>
XR600R	89-00	51-1042	<b>504-016</b>
XR650L	93-08	51-1042	<b>504-016</b>

### Kawasaki ATV

KLF220A1-A15 Bayou 220	88-02	50-2042	<b>504-025</b>
KLF250A1-A9F Bayou 250	03-09	50-2042	<b>504-025</b>
KLF300B1-B17 Bayou 300	88-04	50-2041	<b>504-024</b>
KLF300C1-C16 Bayou 300 4x4	89-06	50-2041	<b>504-024</b>

### Kawasaki Offroad

KX60B1-B19	85-03	51-2003	<b>504-022</b>
KX65A1-A9F	00-09	51-2004	<b>504-023</b>
KX80E3	1985	51-2003	<b>504-022</b>



### Kawasaki Offroad

Model	Year	K&S No.	Order No.
KX80G1/G2	86-87	51-2003	<b>504-022</b>
KX80J Big Wheel	1987	51-2003	<b>504-022</b>
KX80L1/L2/L3	88-90	51-2003	<b>504-022</b>
KX80N1/N2/N3	88-90	51-2003	<b>504-022</b>
KX80R1-R7	91-97	51-2003	<b>504-022</b>
KX80T1/T2/T3/T4 Big Wheel	91-94	51-2003	<b>504-022</b>
KX80W1/W2/W3	98-00	51-2004	<b>504-023</b>
KX85A1-A9F	01-09	51-2004	<b>504-023</b>
KX100B5/B6/B7	95-97	51-2003	<b>504-022</b>
KX100C1/C2/C3	98-00	51-2004	<b>504-023</b>
KX100D1-D9F	01-09	51-2004	<b>504-023</b>
KX125F1/G1	88-89	51-2005	—
KX125H1/H2	90-91	51-2005	—
KX125J1/J2	92-93	51-2005	—
KX125K1/K2/K3/K4/K5	94-98	51-2002	<b>504-021</b>
KX125L1/L2/L3/L4	99-02	51-2002	<b>504-021</b>
KX125M1/M2/M3	03-05	51-2002	<b>504-021</b>
KDX250D1/D2/D3/D4	91-94	51-2001	<b>504-020</b>
KX250F1/G1	88-89	51-2001	<b>504-020</b>
KX250H1/H2	90-91	51-2001	<b>504-020</b>
KX250J1/J2	92-93	51-2001	<b>504-020</b>
KX250K1/K2/K3/K4/K5	94-98	51-2001	<b>504-020</b>
KX250L1/L2/L3/L4	99-02	51-2001	<b>504-020</b>
KX500B2/C1/D1	86-88	51-2006	<b>504-026</b>
KX500E1-E16	89-04	51-2006	<b>504-026</b>

### KTM Offroad

50 SX/SXR Adventure	97-99	51-6001	<b>504-090</b>
50 SX/SXR Mini-Adventure	00-01	51-6001	<b>504-090</b>
50 SX/SXR Pro-Jr., Pro-Sr.	97-01	51-6001	<b>504-090</b>
50 SX Jr.Adventure	00-01	51-6001	<b>504-090</b>
50 SX Sr.Adventure	00-01	51-6001	<b>504-090</b>
50 Mini-Adventure	02-03	51-6002	<b>504-091</b>
50 Junior Adventure	02-03	51-6002	<b>504-091</b>
50 Senior Adventure	02-03	51-6002	<b>504-091</b>
50 SX Pro Junior LC	01-03	51-6002	<b>504-091</b>
50 SX Pro Senior LC	01-03	51-6002	<b>504-091</b>
60 SX	98-00	51-6003	<b>504-092</b>
65 SX	98-03	51-6003	<b>504-092</b>
125 SX/MXS/EXC	98-04	51-6004	<b>504-093</b>
200 SX/MXS/EXC	98-04	51-6004	<b>504-093</b>
250 SX/MXC/EXC	92-99	51-6005	<b>504-094</b>
250 SX	00-02	51-6005	<b>504-094</b>
250 MXC/EXC	00-03	51-6005	<b>504-094</b>
(except EXC racing 02-03)			
250 SX/MXC/EXC	2004	51-6005	<b>504-094</b>
(except EXC racing 04)			
300 SX/MXC/EXC	92-04	51-6005	<b>504-094</b>
360 SX/MXC/EXC	96-97	51-6005	<b>504-094</b>
380 SX/MXC/EXC	98-02	51-6005	<b>504-094</b>

## Polaris ATV

Model	Year	K&S No.	Order No.
2 x 4	1990	50-5003	<b>504-098</b>
4 x 4	1990	50-5003	<b>504-098</b>
250 2 x 4	1993	50-5003	<b>504-098</b>
250 4 x 4	1993	50-5003	<b>504-098</b>
250 6 x 6	1993	50-5003	<b>504-098</b>
300 2 x 4	94-95	50-5003	<b>504-098</b>
300 4 x 4	94-95	50-5003	<b>504-098</b>
300 6 x 6	1994	50-5003	<b>504-098</b>
350L 2 x 4	90-93	50-5001	<b>504-097</b>
350L 4 x 4	90-93	50-5001	<b>504-097</b>
350L 6 x 6	1993	50-5001	<b>504-097</b>
400L 2 x 4	94-95	50-5001	<b>504-097</b>
400L 4 x 4	1994	50-5001	<b>504-097</b>
400L 6 x 6	94-96	50-5001	<b>504-097</b>
Big Boss	1990	50-5003	<b>504-098</b>
Big Boss 250 6 x 6	1992	50-5003	<b>504-098</b>
Big Boss 400L 6 x 6	1997	50-5003	<b>504-098</b>
Big Boss 4 x 6	1989	50-5003	<b>504-098</b>
Big Boss 4 x 6	91-92	50-5003	<b>504-098</b>
Big Boss 6 x 6	1991	50-5003	<b>504-098</b>
Cyclone	1987	50-5003	<b>504-098</b>
Scrambler	85-86	50-5003	<b>504-098</b>
Scrambler	1996	50-5001	<b>504-097</b>
Scrambler 2 x 4	2000	50-5001	<b>504-097</b>
Scrambler 4 x 4	1995	50-5001	<b>504-097</b>
Scrambler 400	98-00	50-5001	<b>504-097</b>
Scrambler 400L	1997	50-5001	<b>504-097</b>
Scrambler 400 2 x 4	01-02	50-5001	<b>504-097</b>
Scrambler 400 4 x 4	2002	50-5001	<b>504-097</b>
Sport 400	1995	50-5001	<b>504-097</b>
Sport 400	1999	50-5001	<b>504-097</b>
Sport 400L	1994	50-5001	<b>504-097</b>
Sport 400L	96-98	50-5001	<b>504-097</b>
Sportsman 4 x 4	93-96	50-5001	<b>504-097</b>
Sportsman 400L	1997	50-5001	<b>504-097</b>
Trailblazer	90-95	50-5003	<b>504-098</b>
Trailblazer	97-98	50-5003	<b>504-098</b>
Trailblazer	01-02	50-5003	<b>504-098</b>
Trailblazer	04-05	50-5003	<b>504-098</b>
Trailblazer ES	1996	50-5003	<b>504-098</b>
Trailblazer 250	99-00	50-5003	<b>504-098</b>
Trailblazer 250	2003	50-5003	<b>504-098</b>
Trailblazer 400	2003	50-5001	<b>504-097</b>
Trail Boss	85-99	50-5003	<b>504-098</b>
Trail Boss 2 x 4	88-89	50-5003	<b>504-098</b>
Trail Boss 2 x 4	91-92	50-5003	<b>504-098</b>
Trail Boss 4 x 4	87-89	50-5003	<b>504-098</b>
Trail Boss 4 x 4	91-92	50-5003	<b>504-098</b>
Trail Boss 350L 2 x 4	91-92	50-5001	<b>504-097</b>
Trail Boss 350L 4 x 4	91-92	50-5001	<b>504-097</b>
Xplorer	00-01	50-5003	<b>504-098</b>
Xplorer 4 x 4	2002	50-5003	<b>504-098</b>
Xplorer 300	96-99	50-5003	<b>504-098</b>
Xplorer 400	99-02	50-5001	<b>504-097</b>
Xplorer 400 4 x 4	1995	50-5001	<b>504-097</b>
Xplorer 400L	96-98	50-5001	<b>504-097</b>
Xpress 300	96-99	50-5003	<b>504-098</b>
Xpress 400	1996	50-5001	<b>504-097</b>
Xpress 400L	1997	50-5001	<b>504-097</b>

## Suzuki ATV

LT250RF/RG Quadracer	85-86	50-3001	<b>504-031</b>
LT250RJ/RK/RL/RM/RN Quadracer	88-92	50-3002	<b>504-032</b>
LT-F250J/K/L/M/N/P Quadrunner	88-93	50-3041	<b>504-038</b>
LT-F250R/S/T/V/W/X Quadrunner	94-99	50-3041	<b>504-038</b>
LT-F250FX-FK2 Quadrunner	99-02	50-3041	<b>504-038</b>
LT-4WDH-WDV 4x4 Quadrunner	87-97	50-3041	<b>504-038</b>
LT-F4WDV/WDW Quadrunner	97-98	50-3041	<b>504-038</b>
LT-F4WDXM-WDXW King Quad	91-98	50-3041	<b>504-038</b>
LT500RJ/RK/RL Quadracer	88-90	50-3002	<b>504-032</b>

## Suzuki Offroad

Model	Year	K&S No.	Order No.
RM60K3	2003	51-2003	<b>504-022</b>
RM65K3/K4/K5	03-05	51-2004	<b>504-023</b>
RM80L/M/N/P/R/S	90-95	51-3003	<b>504-035</b>
RM80T/V/W/Y/K1	96-01	51-3003	<b>504-035</b>
RM85K2/K3/K4/K5/K6/K7/K8	02-08	51-3003	<b>504-035</b>
RM100K3	2003	51-2004	<b>504-023</b>
RM125N/P/R/S/T/V/W/X/Y	92-00	51-3001	<b>504-033</b>
RM125K1/K2/K3	01-03	51-3001	<b>504-033</b>
RM250R/S/T/V/W/X/Y	94-00	51-3002	<b>504-034</b>
RM250K1/K2/K3	01-02	51-3002	<b>504-034</b>
RM250K4/K5/K6/K7/K8	03-08	51-3004	<b>504-036</b>
RMX250S/T/V/W	95-98	51-3002	<b>504-034</b>

## Yamaha ATV

YFS200U-T Blaster	88-05	50-4001	<b>504-041</b>
YFM350ERT/ERU/ERW Moto-4	87-89	50-4041	<b>504-045</b>
YFM350ERA Moto-4	1990	50-4041	<b>504-045</b>
YFM350ERD/ERE Moto-4	92-93	50-4041	<b>504-045</b>
YFM350ERF/ERG Moto-4	94-95	50-4041	<b>504-045</b>
YFM350FHL/FHLC Big Bear	1999	50-4041	<b>504-045</b>
YFM350FWBJ-FWBL Big Bear	97-99	50-4041	<b>504-045</b>
YFM350FWT-FWJ Big Bear	87-97	50-4041	<b>504-045</b>
YFM350FXG-FXT Wolverine	95-02	50-4041	<b>504-045</b>
YFM350UH/UJ/UK Big Bear 2WD	96-98	50-4041	<b>504-045</b>
YFM350UL Big Bear 2WD	1999	50-4041	<b>504-045</b>
YFM350XT-XR Warrior	87-04	50-4042	<b>504-046</b>
YFZ350T-V Banshee	87-06	50-4002	<b>504-042</b>
YFZ350SET Banshee	2005	50-4002	<b>504-042</b>
YFM400FWE-FWK/FWKC Kodiak	93-98	50-4041	<b>504-045</b>
YFM400FWL	1999	50-4041	<b>504-045</b>
YFM400FVNHM Big Bear 4WD	2000	50-4041	<b>504-045</b>
Buckmaster			
YFM400FVNM/FVNM/C Big Bear	2000	50-4041	<b>504-045</b>
YFM400NN/NHN/P/HP/NR/S	01-04	50-4041	<b>504-045</b>
Big Bear 2WD			
YFM660RN/RNC/RP/RPB Raptor	01-02	50-4043	<b>504-056</b>
YFM660RR/RRC/RS/RT Raptor	03-05	50-4043	<b>504-056</b>
YFM660RLER/RLES	03-04	50-4043	<b>504-056</b>
Raptor 660R Limited Edition Blk			
YFM660RSET Raptor SE	2005	50-4043	<b>504-056</b>

## Yamaha Offroad

YZ80E1/F1/G1/H1	93-96	51-4004	<b>504-050</b>
YZ80J1/K1/L1/M1/N1	97-01	51-4004	<b>504-050</b>
YZ85P/R/S/T/V/W1/X	02-08	51-4007	<b>504-055</b>
YZ125F/G/H/J1	94-97	51-4001	<b>504-047</b>
YZ125J1/K1/L1/M1	98-00	51-4003	<b>504-049</b>
YZ125N/P/R/S1	01-04	51-4006	<b>504-052</b>
WR250ZB-ZJ	91-97	51-4002	<b>504-048</b>
YZ250WRW/WRA Offroad	89-90	51-4002	<b>504-048</b>
YZ250UW/A1/B1/D1/E1	88-93	51-4002	<b>504-048</b>
YZ250F1/G1/H1/J1/K1	94-98	51-4002	<b>504-048</b>
YZ250L1/M1/N1	99-01	51-4005	<b>504-051</b>
YZ250P/R/S1/T1/V/W/X/X1	02-08	51-4005	<b>504-051</b>
WR400FK/FL/FM	98-00	51-4041	<b>504-053</b>
YZ400FK/FL	98-99	51-4041	<b>504-053</b>
WR426FN/FP	01-02	51-4041	<b>504-053</b>
YZ426FM/FN/FP	00-02	51-4041	<b>504-053</b>
WR450FR	2003	51-4041E	<b>504-054</b>
WR450FS/FT	04-05	51-4041	<b>504-053</b>
YZ450FR	2003	51-4041E	<b>504-054</b>
YZ450FS/FT/FV/FW/FX	04-08	51-4041	<b>504-053</b>

# Stator Cover Gaskets



## Stator Cover Gaskets (Alternator/Generator)

Sold each. *Made in Japan.*

### Honda Street

Model	Year	Vesrah Ref	Order No.
CB350F/F1 Super Sport	72-74	VY-1003	<b>640-1003</b>
CB350G	1973	VY-1004	<b>640-1004</b>
CB350K0/K1-K4 Super Sport	68-73	VY-1004	<b>640-1004</b>
CL350K0/K1-K5 Scrambler	68-73	VY-1004	<b>640-1004</b>
SL350K0/K1/K2 Moto Sport	70-72	VY-1004	<b>640-1004</b>
CB360K0	1974	VY-1002	<b>640-1002</b>
CB360T	75-76	VY-1004	<b>640-1004</b>
CB400F Super Sport	75-77	VY-1003	<b>640-1003</b>
CB450D Super Sport 450	1967	VY-1002	<b>640-1002</b>
CB450K0 Super Sport 450	65-68	VY-1002	<b>640-1002</b>
CB450K1-K7 Super Sport 450	68-74	VY-1002	<b>640-1002</b>
CL450 Scrambler 450	1967	VY-1002	<b>640-1002</b>
CL450K1-K6 Scrambler 450	68-74	VY-1002	<b>640-1002</b>
CB500T	75-76	VY-1002	<b>640-1002</b>
CB600F 559	04-06	VK-1081	<b>641-1081</b>
CBR600F2 Hurricane	91-94	VK-1081	<b>641-1081</b>
CBR600F3 Hurricane	95-98	VK-1081	<b>641-1081</b>
CBR600SE	1998	VK-1081	<b>641-1081</b>
CBR600SJR Replica	1996	VK-1081	<b>641-1081</b>
NX650	88-89	VK-1070	<b>641-1070</b>
XR650L Dual Sport	93-07	VK-1070	<b>641-1070</b>
CB750A Automatic	76-78	VY-1001	<b>640-1001</b>
CB750C Custom	80-82	VK-1009	<b>641-1009</b>
CB750F Super Sport	75-78	VY-1001	<b>640-1001</b>
CB750F Super Sport	79-82	VK-1009	<b>641-1009</b>
CB750K0/K1-K5 750 Four	69-75	VY-1001	<b>640-1001</b>
CB750K 750 Four	76-78	VY-1001	<b>640-1001</b>
CB750K	79-82	VK-1009	<b>641-1009</b>
CB750L LTD	1979	VK-1009	<b>641-1009</b>

### Honda ATV

ATC250ES	1985	VK-1034	<b>641-1034</b>
ATC250SX	1985	VK-1034	<b>641-1034</b>
TRX250X Fourtrax	87-88	VK-1060	<b>641-1060</b>
TRX250X Fourtrax	91-92	VK-1060	<b>641-1060</b>
TRX300 Fourtrax 300	88-00	VK-1034	<b>641-1034</b>
TRX300EX Fourtrax 300 EX	93-00	VK-1087	<b>641-1087</b>
TRX300EX Sportrax 300 EX	01-06	VK-1087	<b>641-1087</b>
TRX300FW Fourtrax 300 4x4	1988	VK-1034	<b>641-1034</b>
TRX300FW Fourtrax 300 4x4	90-00	VK-1034	<b>641-1034</b>
TRX400EX Fourtrax 400EX	99-00	VK-1088	<b>641-1088</b>
TRX400EX Sportrax 400EX	01-06	VK-1088	<b>641-1088</b>

### Honda Dual Sport & Offroad

XL75	77-79	VK-1019	_____
XR75	77-79	VK-1019	_____
XL80S	80-85	VK-1019	_____
XR80	79-84	VK-1019	_____
XR80R	85-88	VK-1019	_____
XR80R	90-91	VK-1019	_____
XR80R	93-03	VK-1019	_____
CRF80F	04-06	VK-1019	_____
CRF100F	03-06	VK-1019	_____
XR100R	92-03	VK-1019	_____
XR250R	96-04	VK-1086	<b>641-1086</b>
XR400R	92-03	VK-1088	<b>641-1088</b>
XR600R	88-00	VK-1028	<b>641-1028</b>
NX650	88-89	VK-1070	<b>641-1070</b>
XR650L Dual Sport	93-07	VK-1070	<b>641-1070</b>

## Kawasaki Street

Model	Year	Vesrah Ref	Order No.
EN450A1-A6 LTD 454	85-90	VY-4031	<b>640-4031</b>
EN500A1-A7 Vulcan 500	90-96	VY-4031	<b>640-4031</b>
EN500C1-C10 Vulcan 500 LTD	96-05	VY-4031	<b>640-4031</b>
EN500C6F/ C7F Vulcan 500 LTD	06-07	VY-4031	<b>640-4031</b>
EX500A1-A7	87-93	VY-4031	<b>640-4031</b>
EX500D1/D2/D3 Ninja 500	94-96	VY-4031	<b>640-4031</b>
EX500D4-D12 Ninja 500R	97-05	VY-4031	<b>640-4031</b>
EX500D6F/ D7F Ninja 500R	06-07	VY-4031	<b>640-4031</b>
KZ550A1/A2/A3/A4	80-83	VY-4014	<b>640-4014</b>
KZ550C1/C2/C3/C4 LTD	80-83	VY-4014	<b>640-4014</b>
KZ550D1 GPz	1981	VY-4014	<b>640-4014</b>
KZ550F1 Spectre	1983	VY-4014	<b>640-4014</b>
KZ550F2 LTD	1984	VY-4014	<b>640-4014</b>
KZ550H1/H2 GPz	82-83	VY-4014	<b>640-4014</b>
KZ550M1 LTD	1983	VY-4014	<b>640-4014</b>
ZR550B1/B2/B3/B4 Zephyr	90-93	VY-4014	<b>640-4014</b>
ZX550A1/A2/A3 GPz	84-86	VY-4014	<b>640-4014</b>
KL600B1/B2 KLR600 Dual Sport	85-86	VY-4033	<b>640-4033</b>
ZL600A1/A2 Eliminator	86-87	VY-4028	<b>640-4028</b>
ZL600B2/B3 Eliminator	96-97	VY-4028	<b>640-4028</b>
ZX600A1/A2/A3 Ninja 600R	85-87	VY-4028	<b>640-4028</b>
ZX600B1 Ninja 600RX	1987	VY-4028	<b>640-4028</b>
ZX600C1-C10 Ninja 600R	88-97	VY-4028	<b>640-4028</b>
KL650A1-A19 KLR650 Dual Sport	87-05	VY-4033	<b>640-4033</b>
KL650A6F/ A7F KLR650 Dual Sport	06-07	VY-4033	<b>640-4033</b>
KL650B2/B3 Tengai KLR650	90-91	VY-4033	<b>640-4033</b>
KZ650B2/B2A/B3	78-79	VY-4017	<b>640-4017</b>
KZ650C2/C3 Custom	78-79	VY-4017	<b>640-4017</b>
KZ650D1/D1A/D2 SR	78-79	VY-4017	<b>640-4017</b>
KZ650E1 LTD	1980	VY-4017	<b>640-4017</b>
KZ650F1	1980	VY-4017	<b>640-4017</b>
KZ650H1/H2/H3 CSR	81-83	VY-4017	<b>640-4017</b>
KZ700A1	1984	VY-4017	<b>640-4017</b>
ZN700A1/A2 LTD	84-85	VY-4017	<b>640-4017</b>
KZ750B1/B2/B3/B4 2-cylinder	76-79	VY-4019	<b>640-4018</b>
KZ750E1/E2/E3	80-82	VY-4017	<b>640-4017</b>
KZ750F1/F2 Spectre & LTD	83-84	VY-4017	<b>640-4017</b>
KZ750G1 LTD 2-cylinder	1980	VY-4018	<b>640-4018</b>
KZ750H1/H2/H3/H4 LTD	80-83	VY-4017	<b>640-4017</b>
KZ750K1/K2 2-cylinder	83-84	VY-4018	<b>640-4018</b>
KZ750L3	1983	VY-4017	<b>640-4017</b>
KZ750M1 CSR 2-cylinder	1983	VY-4018	<b>640-4018</b>
KZ750N1/N2 Spectre	82-83	VY-4017	<b>640-4017</b>
KZ750R1 GPz	1982	VY-4017	<b>640-4017</b>
ZX750A1/A2/A3 GPz	83-85	VY-4017	<b>640-4017</b>
ZX750E1/E2 GPz Turbo	84-85	VY-4017	<b>640-4017</b>
KZ900A4/A5	76-77	VY-4001	<b>640-4001</b>
KZ900B1 LTD	1976	VY-4001	<b>640-4001</b>
ZL900 A1, A2	85-86	VY-4026	<b>640-4026</b>
ZL900 A1/A1L, A2, A3	84-86	VY-4026	<b>640-4026</b>
Z1/Z1A/Z1B-900	73-75	VY-4001	<b>640-4001</b>
KG1000 A1-A6	86-91	VY-4026	<b>640-4026</b>
ZG1000 A6F	06	VY-4026	<b>640-4026</b>
ZG1000 A7-A19	92-05	VY-4026	<b>640-4026</b>
KZ1000A1/A2	77-78	VY-4001	<b>640-4001</b>
KZ1000A3/A3A/A4 MKII	79-80	VY-4001	<b>640-4001</b>
KZ1000B1/B2/B3/B4 LTD	77-80	VY-4001	<b>640-4001</b>
KZ1000C1/C1A/C2/C3/C4 Police	78-81	VY-4001	<b>640-4001</b>
KZ1000D1 Z1R	1978	VY-4001	<b>640-4001</b>
KZ1000D3 Z1R	1980	VY-4001	<b>640-4001</b>
KZ1000E1/E2 Shaft ST	79-80	VY-4001	<b>640-4001</b>
KZ1000G1 Classic LTD	1980	VY-4001	<b>640-4001</b>
KZ1000J1/J2/J3	81-83	VY-4001	<b>640-4001</b>
KZ1000K1/K2 LTD	81-82	VY-4001	<b>640-4001</b>
KZ1000M1/M2 CSR	81-82	VY-4001	<b>640-4001</b>
KZ1000P1-P21 Police	82-02	VY-4001	<b>640-4001</b>
KZ1000R1/R2 Replica	82-83	VY-4001	<b>640-4001</b>
ZX1000 A1, A2	86-87	VY-4026	<b>640-4026</b>
ZX1000 B1-B3	88-90	VY-4026	<b>640-4026</b>
KZ1100A1/A2/A3 Shaft	81-83	VY-4001	<b>640-4001</b>
KZ1100B1/B2 GPz	81-82	VY-4001	<b>640-4001</b>
KZ1100D1/D2 Spectre	82-83	VY-4001	<b>640-4001</b>
KZ1100L1 LTD	1983	VY-4001	<b>640-4001</b>
ZN1100B1/B2 LTD	84-85	VY-4001	<b>640-4001</b>
ZX1100A1/A2 GPz	83-84	VY-4001	<b>640-4001</b>
ZX1100 D7-D9	99-04	VY-4026	<b>640-4026</b>
ZR1200 A1-A5	01-05	VY-4026	<b>640-4026</b>



## Kawasaki Street

Model	Year	Vesrah Ref	Order No.
KZ1300A1/A2/A3/A4	79-82	VY-4027	<b>640-4027</b>
KZ1300B2 Tourer	1980	VY-4027	<b>640-4027</b>
ZN1300A1-A6 Voyager	83-87	VY-4027	<b>640-4027</b>

## Kawasaki ATV

Model	Year	Vesrah Ref	Order No.
KLF220A1-A15 Bayou 220	88-02	VY-4036	<b>640-4036</b>
KLF250A1/A2/A3/A6F Bayou 250	03-06	VY-4036	<b>640-4036</b>
KSF250A1-A17 Mojave	87-03	VY-4034	<b>640-4034</b>
KSF250A18 KFX250 Mojave	2004	VY-4034	<b>640-4034</b>
KXT250A1/A2 Tecate 3	84-85	VY-4004	<b>640-4004</b>
KXT250B1/B2 Tecate 3	86-87	VY-4004	<b>640-4004</b>
KEF300A1-A6 Lakota 300	95-00	VY-4049	<b>640-4049</b>
KEF300B1/B2/B3 Lakota Sport	01-03	VY-4049	<b>640-4049</b>
KLF300A1/A2 Bayou 300	86-87	VY-4029	<b>640-4029</b>
KLF300B1 Bayou 300	1988	VY-4029	<b>640-4029</b>
KLF300B2-B17 Bayou 300	89-04	VY-4049	<b>640-4049</b>
KLF300C1-C16 Bayou 300 4x4	89-04	VY-4037	<b>640-4037</b>
KVF300A1/A2/A3/A4 Prairie 300 4x4	99-02	VY-4049	<b>640-4049</b>
KVF300B1/B2/B3/B4 Prairie 300	99-02	VY-4049	<b>640-4049</b>

## Kawasaki Dual Sport

Model	Year	Vesrah Ref	Order No.
KX80 G1, G2 Mini	86-87	VY-4026	<b>640-4025</b>
KX80 J2 Big Wheel	1987	VY-4025	<b>640-4025</b>
KX80 L2 Mini	1989	VY-4025	<b>640-4025</b>
KX80 N2 Big Wheel	1989	VY-4026	<b>640-4025</b>
KX250 E1	1987	VY-4043	<b>640-4043</b>
KX250 F1	1988	VY-4043	<b>640-4043</b>
KX250 G1	1989	VY-4043	<b>640-4043</b>
KX250 H1, H2	90-91	VY-4044	<b>640-4044</b>
KX500 E1-E16	89-04	VY-4011	<b>640-4011</b>
KL600B1/B2 KLR600	85-86	VY-4033	<b>640-4033</b>
KL650A1-A19 KLR650	87-05	VY-4033	<b>640-4033</b>
KL650A6F KLR650	2006	VY-4033	<b>640-4033</b>
KL650B2/B3 Tengai KLR650	90-91	VY-4033	<b>640-4033</b>

## Suzuki Street

Model	Year	Vesrah Ref	Order No.
GS450ET/EX/EZ/ED	80-83	VY-3002	<b>640-3002</b>
GS450LT/LX/LZ/LD	80-83	VY-3002	<b>640-3002</b>
GS450LF/LG/LH/LJ	85-88	VY-3002	<b>640-3002</b>
GS450ST/SX	81-82	VY-3002	<b>640-3002</b>
GS450TX/TZ	81-82	VY-3002	<b>640-3002</b>
GS450TX/TZ/TXZ/TXD	82-83	VY-3002	<b>640-3002</b>
GS500EK-EY	89-00	VY-3002	<b>640-3002</b>
GS500EK1/EK2	01-02	VY-3002	<b>640-3002</b>
GS500FK4/FK5/FK6	04-06	VY-3002	<b>640-3002</b>
GS550B/C/EC/N/EN	77-79	VY-3003	<b>640-3003</b>
GS550ET	1980	VY-3003	<b>640-3003</b>
GS550ED/ESD	1983	VY-3009	<b>640-3009</b>
GS550ES3/ESE/EF/ESF/ESG	83-86	VY-3009	<b>640-3009</b>
GS550LN/LT/LX/LZ	79-82	VY-3003	<b>640-3003</b>
GS550LD	1983	VY-3009	<b>640-3009</b>
GS550LF/LG	85-86	VY-3009	<b>640-3009</b>
GS550MZ Katana	1982	VY-3003	<b>640-3003</b>
GS550TX	1981	VY-3003	<b>640-3003</b>
GSF600S T-K3	96-03	VY-3042	<b>640-3042</b>
GSX600F M-K6	91-06	VY-3042	<b>640-3042</b>
GSX750F L	89-06	VY-3042	<b>640-3042</b>
LS650 Boulevard S40	05-06	VY-3035	<b>640-3035</b>
GS700EF/ESF	1985	VY-3007	<b>640-3007</b>
VS700GLFG/GLFH Intruder	86-87	VY-3045	<b>640-3045</b>
VS700GLPG/GLPH Intruder	86-87	VY-3045	<b>640-3045</b>
VS700GLEFG/GLEFH Intruder	86-87	VY-3045	<b>640-3045</b>
VS700GLEPG/GLEPH Intruder	86-87	VY-3045	<b>640-3045</b>
GS750B/C/EC/N/EN	77-79	VY-3004	<b>640-3004</b>
GS750ET/EX/EZ	80-82	VY-3005	<b>640-3005</b>
GS750ED/ESD	1983	VY-3007	<b>640-3007</b>
GS750LN	1979	VY-3004	<b>640-3004</b>
GS750LT/LX	80-81	VY-3005	<b>640-3005</b>
GS750TZ/TD	82-83	VY-3005	<b>640-3005</b>

## Suzuki Street

Model	Year	Vesrah Ref	Order No.
GS750SD Katana	1983	VY-3005	<b>640-3005</b>
VS750GLPJ/K/L/M	88-91	VY-3045	<b>640-3045</b>
VS800GLN-GLK4 Intruder	92-04	VY-3045	<b>640-3045</b>
VS800 Boulevard S50	05-06	VY-3045	<b>640-3045</b>
VX800L/M/N/P	90-93	VY-3045	<b>640-3045</b>
GS850GN/GT/GX/GZ/GD	79-83	VY-3004	<b>640-3004</b>
GS850GLT/GLX/GLZ/GLD	80-83	VY-3004	<b>640-3004</b>
GS1000C/EC/N/EN/ET	78-80	VY-3004	<b>640-3004</b>
GS1000GT/GX	80-81	VY-3004	<b>640-3004</b>
GS1000GLT/GLX	80-81	VY-3004	<b>640-3004</b>
GS1000LN	1979	VY-3004	<b>640-3004</b>
GS1000SN/ST	79-80	VY-3004	<b>640-3004</b>
GS1000SZ Katana	1983	VY-3005	<b>640-3005</b>
GS1100ET/EX/EZ	80-82	VY-3005	<b>640-3005</b>
GS1100ED/ESD	1983	VY-3005	<b>640-3005</b>
GS1100GZ/GLZ/GD/GLD	82-83	VY-3004	<b>640-3004</b>
GS1100GKZ/GK2/GKD/GKE	82-84	VY-3004	<b>640-3004</b>
GS1100LT	1980	VY-3005	<b>640-3005</b>
GS1100SD Katana	1983	VY-3005	<b>640-3005</b>
GSX1100G M,N	91-92	VY-3049	<b>640-3049</b>
GSX-R1100 K-N	89-92	VY-3043	<b>640-3043</b>
GS1150ES3/ESE/EF/ESF/EF2	83-85	VY-3005	<b>640-3005</b>
GS1150EG/ESG	1986	VY-3005	<b>640-3005</b>
VS1400GLPH-GLPY Intruder	87-00	VY-3046	<b>640-3046</b>
VS1400GLPK1-GLPK4 Intruder	01-04	VY-3046	<b>640-3046</b>
VS1400 Boulevard S83	05-06	VY-3046	<b>640-3046</b>

## Suzuki ATV

Model	Year	Vesrah Ref	Order No.
LT230SF/SG/SH/SJ QuadSport	85-88	VY-3021	<b>640-3021</b>
LT250EFF/EFG Quadrunner	85-86	VY-3022	<b>640-3022</b>
LT250RH-RN Quadracer	87-92	VY-3041	<b>640-3041</b>
LT250SK/SL QuadSport	89-90	VY-3021	<b>640-3021</b>
LT-4WDH-LT-4WDS Quadrunner	87-95	VY-3027	<b>640-3027</b>
LT-F250J/K/L/M/N/P/R Quadrunner	88-94	VY-3027	<b>640-3027</b>
LT300EH/EJ/EK	87-89	VY-3022	<b>640-3022</b>
LT-F4WDXM/N/P King Quad	91-93	VY-3027	<b>640-3027</b>
LT500RJ/RK/RL Quadracer	88-90	VY-3047	<b>640-3047</b>

## Suzuki Dual Sport & Offroad

Model	Year	Vesrah Ref	Order No.
DR250L/M/N/P	90-93	VY-3044	<b>640-3044</b>
DR250SL/SM/SN Dual Sport	90-92	VY-3044	<b>640-3044</b>
DR250SEP/SER/SES Dual Sport	93-95	VY-3048	<b>640-3044</b>
RM250 R,S	94-95	VY-3053	<b>640-3043</b>
DR350L/M/N/P/R/S/T/V/W/X	90-99	VY-3044	<b>640-3044</b>
DR350SL/SM/SN/SP Dual Sport	90-93	VY-3044	<b>640-3044</b>
DR350SER-SEX Dual Sport	94-99	VY-3048	<b>640-3048</b>



# Stator Cover Gaskets

## Yamaha Street

Model	Year	Vesrah Ref	Order No.
XT250L/LC	1984	VK-2017	641-2017
XT350N/NC-M/MC Dual Sport	85-00	VK-2017	641-2017
XT550J/K Dual Sport	82-83	VK-2011	641-2011
XT600L/LC-W/WC Dual Sport	84-89	VK-2011	641-2011
FZR400U/SUC-A/SAC	88-90	VK-2032	641-2032
FZR600W/WC/A	89-90	VK-2032	641-2032
FZR600RA/RAC-RL/RLC	90-99	VK-2032	641-2032
SRX600S/SC	1986	VK-2011	641-2011
FZ700 T/TTC Genesis	87	VK-2024	641-2024
FZ750 N, S/SC	85-86	VK-2024	641-2024
FZ750 U/UC	88	VK-2024	641-2024
FZR750R T, U Genesis	87-88	VK-2024	641-2024
YZR750R F/FC	94	VK-2024	641-2024
YZF750R H/HC, J/JC, K/KC	96-98	VK-2024	641-2024
XV700L/LC/N/NC Virago	84-85	VK-2021	641-2021
XV700CS/CSC/CT/CTC Virago	86-87	VK-2021	641-2021
XV700SS/SSC Virago	1986	VK-2021	641-2021
XV750H/J/K Virago	81-83	VK-2021	641-2021
XV750MK Midnight Virago	1983	VK-2021	641-2021
XV750U/UC-G/GC Virago	88-95	VK-2021	641-2021
XV750H1/HC1/J1/JC1 Virago	96-97	VK-2021	641-2021
XV920J/K Virago	82-83	VK-2021	641-2021
XV920MK Midnight Virago	1983	VK-2021	641-2021
XV920RH/RJ	81-82	VK-2021	641-2021
FZR1000 U/UC- B/BC	88-91	VK-2024	641-2024
FJ1100 L/LC, N/NC	84-85	VK-2023	641-2023
XV1000L/LC/N/NC Virago	84-85	VK-2021	641-2021
XV1100S/SC-L/LC Virago	86-99	VK-2021	641-2021
XV1100SH/SHC-SK/SKC Virago	96-98	VK-2021	641-2021
FJ1200 S/SC, T/TTC	86-87	VK-2023	641-2023
FJ1200 W/WC-D/DC	89-92	VK-2023	641-2023
FJ1200A D/DC	92	VK-2023	641-2023

## Yamaha ATV

YFM200N Moto-4	1985	VK-2002	641-2002
YFM200DXS/DXT/DXU/DXW Moto-4	86-89	VK-2002	641-2002
YTM200K/L/M Tri-Moto	83-85	VK-2002	641-2002
YTM200EK/EL Tri-Moto	83-84	VK-2002	641-2002
YTM200ERN Tri-Moto	1985	VK-2002	641-2002
YFM225S/T/U Moto-4	86-88	VK-2002	641-2002
YTM225DXK/DXL/DXN Tri-Moto	83-85	VK-2002	641-2002
YTM225DRN/DRS Tri-Moto	85-86	VK-2002	641-2002
YFB250D/E/F/G/H Timberwolf	92-96	VK-2002	641-2002
YFB250FWF-FWM/FWMC	94-00	VK-2002	641-2002
YFB250UH/UJ/UK Timberwolf	96-98	VK-2002	641-2002
YFM350S Raptor	2004	VK-2022	641-2022
YFM350RT/RV Raptor	05-06	VK-2022	641-2022
YFM350RSET/RSEV Raptor 350 SE	05-06	VK-2022	641-2022
YFM350ERT/ERU/ERW/ERA Moto-4	87-90	VK-2022	641-2022
YFM350ERD/ERE/ERF/ERG Moto-4	92-95	VK-2022	641-2022
YFM350FWT-FWJ Big Bear 4WD	87-97	VK-2022	641-2022
YFM350UH/UJ/UK/UL/ULC	96-99	VK-2022	641-2022
YFM350XT-XS/XSC Warrior	87-04	VK-2022	641-2022
YFM400FWG-FWK Kodiak	95-98	VK-2022	641-2022

## Yamaha Dual Sport

XT125 J, K/KC	82-83	VK-2003	641-2003
BW200 N Big Wheel	85	VK-2003	641-2003
XT200 J, K.KC	82-83	VK-2003	641-2003
TT225 S,T	86-87	VK-2003	641-2003
XT250L/LC	1984	VK-2017	641-2017
TT350S/T Offroad	86-87	VK-2017	641-2017
XT350N/NC-M/MC Dual Sport	85-00	VK-2017	641-2017
XT550J/K Dual Sport	82-83	VK-2011	641-2011
TT600K/L/N/S Offroad	83-86	VK-2011	641-2011
XT600L/LC-W/WC Dual Sport	84-89	VK-2011	641-2011



## Sudco Part Number to OEM Cross Reference Stator Cover Gaskets

### Honda

OEM Reference	Vesrah Ref	Order No.
11343-ML7-000	VK-1077	641-1077
11343-MY7-000	VK-1077	641-1077
11343-MZ5-000	VK-1079	641-1079
11343-MZ7-000	VK-1077	641-1077
11392-MV9-670	VK-1081	641-1081
11394-KN4-750	VK-1019	641-1019
11394-149-000	VK-1019	641-1019
11395-HA0-000	VK-1034	641-1034
11395-HC0-680	VK-1060	641-1060
11395-HC0-000	VK-1060	641-1060
11395-HC5-740	VK-1034	641-1034
11395-HM3-670	VK-1087	641-1087
11395-KCY-671	VK-1088	641-1088
11395-KW3-880	VK-1086	641-1086
11395-MG2-000	VK-1028	641-1028
11395-MH1-700	VK-1028	641-1028
11395-MN1-700	VK-1028	641-1028
11395-MY2-620	VK-1070	641-1070
11395-283-306	VY-1002	640-1002
11395-283-000	VY-1002	640-1002
11395-425-306	VK-1009	641-1009
11395-425-000	VK-1009	641-1009
11397-300-306	VY-1001	640-1001
11397-300-040	VY-1001	640-1001
11691-286-306	VY-1004	640-1004
11691-286-000	VY-1004	640-1004
11691-333-306	VY-1003	640-1003
11691-333-000	VY-1003	640-1003

### Kawasaki

11009-1055	VY-4014	640-4014
11009-1090	VY-4027	640-4027
11009-1165	VY-4017	640-4017
11009-1319	VY-4004	640-4004
11009-1328	VY-4018	640-4018
11009-1481	VY-4033	640-4033
11009-1486	VY-4031	640-4031
11009-1502	VY-4028	640-4028
11009-1519	VY-4029	640-4029
11009-1590	VY-4034	640-4034
11009-1672	VY-4036	640-4036
11009-1745	VY-4037	640-4037
11009-1834	VY-4031	640-4031
11009-1987	VY-4017	640-4017
11060-1055	VY-4014	640-4014
11060-1075	VY-4001	640-4001
11060-1150	VY-4028	640-4028
11060-1226	VY-4029	640-4029
11060-1239	VY-4034	640-4034
11060-1417	VY-4027	640-4027
11060-1421	VY-4018	640-4018
11060-1571	VY-4004	640-4004
11060-1649	VY-4036	640-4036
11060-1656	VY-4049	640-4049
11060-1693	VY-4033	640-4033
11060-1716	VY-4037	640-4037
14045-014	VY-4001	640-4001

## Sudco Part Number to OEM Cross Reference Stator Cover Gaskets

### Suzuki

OEM Reference	Vesrah Ref	Order No.
11483-01C00	VY-3041	640-3041
11483-01C10	VY-3041	640-3041
11483-14D01	VY-3044	640-3044
11483-14D03	VY-3044	640-3044
11483-15D01	VY-3048	640-3048
11483-15D02	VY-3048	640-3048
11483-19B00	VY-3027	640-3027
11483-19B13	VY-3027	640-3027
11483-22A10	VY-3021	640-3021
11483-22A00	VY-3021	640-3021
11483-24B01-H17	VY-3035	640-3035
11483-24B00	VY-3035	640-3035
11483-24502-H17	VY-3022	640-3022
11483-24502	VY-3022	640-3022
11483-31301-H17	VY-3007	640-3007
11483-31301	VY-3007	640-3007
11483-38A00	VY-3045	640-3045
11483-38B00-H17	VY-3046	640-3046
11483-38B10	VY-3046	640-3046
11483-38B00	VY-3046	640-3046
11483-41F00	VY-3045	640-3045
11483-43B00	VY-3047	640-3047
11483-43B00	VY-3047	640-3047
11483-43400-H17	VY-3009	640-3009
11483-43400-	VY-3009	640-3009
11483-44110	VY-3002	640-3002
11483-44100	VY-3002	640-3002
11483-45000-H17	VY-3004	640-3004
11483-47000-H17	VY-3003	640-3003
11483-47000	VY-3003	640-3003
11483-49200-H17	VY-3005	640-3005

### Yamaha

1UY-15451-00-00	VK-2022	641-2022
1WG-15451-10-00	VK-2032	641-2032
1WG-15451-00-00	VK-2032	641-2032
24W-15451-00-00	VK-2002	641-2002
3EG-15451-00-00	VK-2021	641-2021
3GD-15451-00-00	VK-2022	641-2022
3SW-15451-00-00	VK-2011	641-2011
3Y1-15451-10-00	VK-2011	641-2011
3Y1-15451-00-00	VK-2011	641-2011
30X-15451-00-00	VK-2017	641-2017
4BD-15451-00-00	VK-2002	641-2002
4EL-15451-00-00	VK-2017	641-2017
4X7-15451-00-00	VK-2021	641-2021

# Left Crankcase Cover Gaskets (Generator & Ignition)

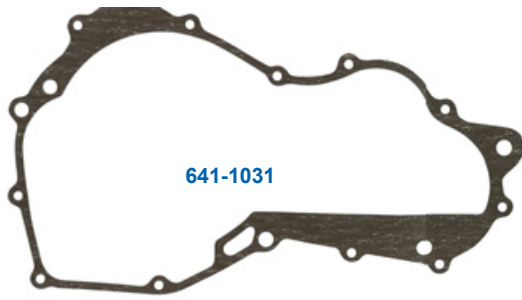

641-1031



640-3037

## Left Side Crankcase Cover Gaskets (Generator & Ignition)

Applications with magneto, rotor, pulse, source and lighting coils.  
Sold each. *Made in Japan.*

### Honda ATV

Model	Year	Vesrah Ref	Order No.
ATC250R	81-84	VK-1031	<b>641-1031</b>
ATC250R	85-86	VK-1033	<b>641-1033</b>
TRX250R	86-89	VK-1033	<b>641-1033</b>

### Honda Offroad

CR80R	85-02	VK-1055	<b>641-1055</b>
CR80RB	00-02	VK-1055	<b>641-1055</b>
CR85R	03-06	VK-1055	<b>641-1055</b>
CR85RB	03-06	VK-1055	<b>641-1055</b>
CR250R	85-01	VK-1053	<b>641-1053</b>
CR500R	87-01	VK-1062	<b>641-1062</b>

### Kawasaki Offroad

KX60A1/A2	83-84	VY-4010	<b>640-4010</b>
KX60B1-B19	85-03	VY-4010	<b>640-4010</b>
KX65A1/A2/A3/A4/A5/A6/A6F	00-06	VY-4010	<b>640-4010</b>
KDX80B2/B3	82-83	VY-4010	<b>640-4010</b>
KDX80C1/C2/C3/C4/C5	84-88	VY-4010	<b>640-4010</b>
KX80C1/C2	81-82	VY-4010	<b>640-4010</b>
KX80E1/E2/E3	83-85	VY-4010	<b>640-4010</b>
KX80G1/G2	86-87	VY-4025	<b>640-4025</b>
KX80J2	1987	VY-4025	<b>640-4025</b>
KX80L1/L2	88-89	VY-4025	<b>640-4025</b>
KX80L3	1990	VY-4051	<b>640-4051</b>
KX80N1/N2	88-89	VY-4025	<b>640-4025</b>
KX80N3	1990	VY-4051	<b>640-4051</b>
KX80R1/R2/R3/R4/R5/R6/R7	91-97	VY-4051	<b>640-4051</b>
KX80T1/T2/T3/T4	91-94	VY-4051	<b>640-4051</b>
KX80W1/W2/W3	98-00	VY-4051	<b>640-4051</b>
KX85A1/A2/A3/A4/A5	01-05	VY-4051	<b>640-4051</b>
KX85A6F	2006	VY-4051	<b>640-4051</b>
KX100B5/B6/B7	95-97	VY-4051	<b>640-4051</b>
KX100C1/C2/C3	98-00	VY-4051	<b>640-4051</b>
KX100D1/D2/D3/D4/D5	01-05	VY-4051	<b>640-4051</b>
KX100D6F	2006	VY-4051	<b>640-4051</b>
KX125F1/G1	88-89	VY-4039	<b>640-4039</b>
KX125H1/H2	90-91	VY-4039	<b>640-4039</b>
KX125K1/K2/K3/K4/K5	94-98	VY-4047	<b>640-4047</b>
KX125L1/L2/L3/L4	99-02	VY-4047	<b>640-4047</b>
KX250C1/C2	83-84	VY-4004	<b>640-4004</b>
KX250D1/D2	85-86	VY-4004	<b>640-4004</b>
KX250E1	1987	VY-4043	<b>640-4043</b>
KX250F1/G1	88-89	VY-4043	<b>640-4043</b>
KX250H1/H2/J1/J2	90-91	VY-4044	<b>640-4044</b>
KX250K1/K2/K3/K4/K5	94-98	VY-4048	<b>640-4048</b>
KX250L1/L2/L3/L4	99-02	VY-4048	<b>640-4048</b>
KX250M1/M2	03-04	VY-4048	<b>640-4048</b>
KX500E1-E16	89-04	VY-4011	<b>640-4011</b>

## Suzuki Offroad

Model	Year	Vesrah Ref	Order No.
RM60K3	2003	VY-4010	<b>640-4010</b>
RM65K3/K4/K5	03-05	VY-4010	<b>640-4010</b>
RM80L-K1	90-01	VY-3037	<b>640-3037</b>
RM250K/L/M/N/P	89-93	VY-3040	<b>640-3040</b>
RM250R/S	94-95	VY-3053	<b>640-3053</b>
RMX250L/M/N/P/R/S/T	89-96	VY-3040	<b>640-3040</b>

## Yamaha Dual Sport & Offroad

YZ80E1/F1/G1/H1/J1/K1/L1/M1/N1	93-01	VK-2038	<b>641-2038</b>
DT100E/F/G/H/J/K	78-83	VK-2010	<b>641-2010</b>
MX100F/G/H/J/K	79-83	VK-2010	<b>641-2010</b>
RT100A	1990	VK-2010	<b>641-2010</b>
RT100D/E/F/G/H/J/K/L/M/MC	92-00	VK-2010	<b>641-2010</b>
XT125J/K/KC Dual Sport	82-83	VK-2003	<b>641-2003</b>
YZ125F1/G1/H1/J1/K1/L1/M1/N1	94-01	VK-2034	<b>641-2034</b>
BW200N/S	85-86	VK-2003	<b>641-2003</b>
BW200ES/ET/EU	86-88	VK-2003	<b>641-2003</b>
XT200J/K/KC Dual Sport	82-83	VK-2003	<b>641-2003</b>
TT225S/T	86-87	VK-2003	<b>641-2003</b>
XT225D/DC-H/HC Serow	92-96	VK-2003	<b>641-2003</b>
WR250ZB/ZD/ZE/ZF/ZG	91-95	VK-2026	<b>641-2026</b>
WR250ZH/ZJ	96-97	VK-2035	<b>641-2035</b>
YZ250WRW/WRA	89-90	VK-2026	<b>641-2026</b>
YZ250U/W/A/B/D/E/F	88-94	VK-2026	<b>641-2026</b>
YZ250H1/J1/K1	96-98	VK-2035	<b>641-2035</b>
WR400FK/FL/FM	98-00	VK-2003	<b>641-2003</b>
YZ400FK/FL	98-99	VK-2003	<b>641-2003</b>
WR426FN/FP	01-02	VK-2003	<b>641-2003</b>
YZ426FM/FN/FP	00-02	VK-2003	<b>641-2003</b>

## Sudco Part Number to OEM Cross Reference Left Crankcase Cover Gaskets (Generator & Ignition)

### Honda

OEM Reference	Vesrah Ref	Order No.
11342-GC4-710	VK-1055	<b>641-1055</b>
11352-HA2-306	VK-1033	<b>641-1033</b>
11352-HA2-000	VK-1033	<b>641-1033</b>
11352-KA4-771	VK-1053	<b>641-1053</b>
11352-KA4-770	VK-1053	<b>641-1053</b>
11352-KA5-690	VK-1062	<b>641-1062</b>
11395-961-306	VK-1031	<b>641-1031</b>
11395-961-000	VK-1031	<b>641-1031</b>

### Kawasaki

11009-1201	VY-4010	<b>640-4010</b>
11009-1289	VY-4011	<b>640-4011</b>
11009-1319	VY-4004	<b>640-4004</b>
11009-1458	VY-4043	<b>640-4043</b>
11009-1536	VY-4025	<b>640-4025</b>
11009-1626	VY-4043	<b>640-4043</b>
11009-1695	VY-4039	<b>640-4039</b>
11009-1807	VY-4051	<b>640-4051</b>

# Left Crankcase Cover Gaskets (Generator & Ignition)



640-3042



641-2024

## LH Gear Cover (Crankcase) Gaskets

Left side engine gear cover gasket for Suzuki sportbike applications. Sold each. **Made in Japan.**

### Suzuki

Model	Year	Vesrah Ref	Order No.
GSF600ST-SK3 Bandit	96-03	VY-3042	<b>640-3042</b>
GSX600FJ/FK/FL Katana	88-90	VY-3026	<b>640-3026</b>
GSX600FM-FK6 Katana	91-06	VY-3042	<b>640-3042</b>
GSX750FK-FK6 Katana	89-06	VY-3042	<b>640-3042</b>
GSX-R750G/H	86-87	VY-3026	<b>640-3026</b>
GSX-R750J/K/L/M/N	88-92	VY-3042	<b>640-3042</b>
GSX-R750RG	1986	VY-3026	<b>640-3026</b>
GSX1100GM/GN/GP Shaft	91-93	VY-3049	<b>640-3049</b>
GSX-R1100G/H/J	86-88	VY-3026	<b>640-3026</b>
GSX-R1100K/L/M/N	89-92	VY-3043	<b>640-3043</b>
GSF1200SV/SAV/SW/SX/SY Bandit	97-00	VY-3043	<b>640-3043</b>
GSF1200SK1/SK2/SK3 Bandit	01-03	VY-3043	<b>640-3043</b>
GSF1200SK4/SK5 Bandit	04-05	VY-3043	<b>640-3043</b>

## Sudco Part Number to OEM Cross Reference Suzuki LH Gear Cover (Crankcase) Gaskets)

### Suzuki

OEM Reference	Vesrah Ref	Order No.
11483-26D00	VY-3049	<b>640-3049</b>
11483-27A00	VY-3026	<b>640-3026</b>
11483-27A20	VY-3042	<b>640-3042</b>
11483-27A10	VY-3042	<b>640-3042</b>
11483-27A01	VY-3042	<b>640-3042</b>
11483-48B21	VY-3043	<b>640-3043</b>
11483-48B00	VY-3043	<b>640-3043</b>

## Sudco Part Number to OEM Cross Reference Left Crankcase Cover Gaskets (Generator & Ignition)

### Kawasaki

OEM Reference	Vesrah Ref	Order No.
11009-1951	VY-4044	<b>640-4044</b>
11009-1964	VY-4011	<b>640-4011</b>
11009-1966	VY-4039	<b>640-4039</b>
11009-1973	VY-4051	<b>640-4051</b>
11009-1974	VY-4010	<b>640-4010</b>
11060-1189	VY-4047	<b>640-4047</b>
11060-1192	VY-4044	<b>640-4044</b>
11060-1352	VY-4048	<b>640-4048</b>
11060-1571	VY-4004	<b>640-4004</b>

### Suzuki

11483-02B50	VY-3037	<b>640-3037</b>
11483-28C01	VY-3040	<b>640-3040</b>
11483-28C00	VY-3040	<b>640-3040</b>
11483-28E10	VY-3053	<b>640-3053</b>
K1100-91974	VY-4010	<b>640-4010</b>

## Engine Sprocket (Crankcase) Cover Gasket

Left side engine sprocket cover gasket for Yamaha sportbike applications. **Made in Japan.** Sold each.

### Honda

Model	Year	Vesrah Ref	Order No.
VFR750F	90-97	VK-1077	<b>641-1077</b>
VF750C Magna	94-03	VK1079	<b>641-1079</b>
VF750CD Magna Deluxe	95-96	VK1079	<b>641-1079</b>
VF750C2 Magna Deluxe	97-00	VK1079	<b>641-1079</b>

### Yamaha

FZ700T/TC	1987	VK-2024	<b>641-2024</b>
FZX700S/SC/T/TC	86-87	VK-2024	<b>641-2024</b>
FZ750N/S/SC	85-86	VK-2024	<b>641-2024</b>
FZ750U/UC	1988	VK-2024	<b>641-2024</b>
FZR750RT/RU	87-88	VK-2024	<b>641-2024</b>
YZF750RF/RFC	1994	VK-2024	<b>641-2024</b>
YZF750RH/RHC/RJ/RJC/RK/RKC	96-98	VK-2024	<b>641-2024</b>
FZR1000T/TC-G/GC	87-95	VK-2024	<b>641-2024</b>
GTS1000AE/AEC/AD/ADC	93-94	VK-2024	<b>641-2024</b>
YZF1000R/RJC	1997	VK-2024	<b>641-2024</b>
FJ1100L/LC/N/NC	84-85	VK-2023	<b>641-2023</b>
FJ1200S/SC/T/TC	86-87	VK-2023	<b>641-2023</b>
FJ1200W/WC/A/AC/B/BC/D/DC	89-92	VK-2023	<b>641-2023</b>
FJ1200AD/ADC/AE/AEC (ABS)	92-93	VK-2023	<b>641-2023</b>

## Sudco Part Number to OEM Cross Reference Engine Sprocket (Crankcase) Cover Gasket

### Honda

OEM Reference	Vesrah Ref	Order No.
11343-MY7-000	VK-1077	<b>641-1077</b>
11343-MZ5-000	VK-1079	<b>641-1079</b>

### Yamaha

1AE-15451-00-00	VK-2024	<b>641-2024</b>
36Y-15451-00-00	VK-2023	<b>641-2023</b>
4BH-15451-00-00	VK-2024	<b>641-2024</b>
4CR-15451-00-00	VK-2023	<b>641-2023</b>
4FM-15451-00-00	VK-2024	<b>641-2024</b>

## Sudco Part Number to OEM Cross Reference Left Crankcase Cover Gaskets (Generator & Ignition)

### Yamaha

OEM Reference	Vesrah Ref	Order No.
1X0-15455-00-00	VK-2010	<b>641-2010</b>
2VM-15451-00-00	VK-2026	<b>641-2026</b>
2VM-15451-11-00	VK-2035	<b>641-2035</b>
2VM-15451-10-00	VK-2035	<b>641-2035</b>
3UL-15455-00-00	VK-2010	<b>641-2010</b>
4JY-15451-01-00	VK-2034	<b>641-2034</b>
4JY-15451-00-00	VK-2034	<b>641-2034</b>
4ES-15455-00-00	VK-2038	<b>641-2038</b>
5BE-15451-00-00	VK-2003	<b>641-2003</b>
15A-15451-02-00	VK-2003	<b>641-2003</b>
15A-15451-00-00	VK-2003	<b>641-2003</b>

# Clutch Cover Gaskets



643-1016

## Clutch Cover Gaskets

Made in Japan. Sold each

### Honda Street

Model	Year	Vesrah Ref	Order No.
CB125S	81-82	VL-1016	<b>643-1016</b>
CB350F/F1 Super Sport	72-74	VL-1014	<b>643-1014</b>
CB350G	1973	VL-1013	<b>643-1013</b>
CB350/K1-K4 Super Sport	68-73	VL-1013	<b>643-1013</b>
CL350/K1-K5 Scrambler	68-73	VL-1013	<b>643-1013</b>
SL350K0/K1/K2 Motosport	70-72	VL-1013	<b>643-1013</b>
CB400F Super Sport	75-77	VL-1008	<b>643-1008</b>
FT500 Ascot	82-83	VL-1041	<b>643-1041</b>
VF500C V30 Magna	84-85	VL-1049	<b>643-1049</b>
VF500F V30 Interceptor	84-85	VL-1049	<b>643-1049</b>
CBR600F Hurricane	87-90	VL-1070	<b>643-1070</b>
CBR600F2 Hurricane	91-94	VL-1083	<b>643-1083</b>
CBR600F3 Hurricane	95-98	VL-1083	<b>643-1083</b>
CBR600SE	1998	VL-1083	<b>643-1083</b>
CBR600SJR Replica	1996	VL-1083	<b>643-1083</b>
VT600C Shadow VLX	88-89	VL-1071	<b>643-1071</b>
VT600C Shadow VLX	91-97	VL-1071	<b>643-1071</b>
VT600C Shadow	99-04	VL-1071	<b>643-1071</b>
VT600CD Shadow VLX Deluxe	93-98	VL-1071	<b>643-1071</b>
VT600CD Shadow Deluxe	99-04	VL-1071	<b>643-1071</b>
VT600CD2 Shadow Deluxe	99-00	VL-1071	<b>643-1071</b>
NT650 Hawk GT	88-91	VL-1071	<b>643-1071</b>
NX650	88-89	VL-1028	<b>643-1028</b>
CB700SC Nighthawk	84-86	VL-1050	<b>643-1050</b>
VF700F Interceptor	84-85	VL-1021	<b>643-1021</b>
VF700S Sabre	84-85	VL-1021	<b>643-1021</b>
VFR700F/F2 Interceptor	86-87	VL-1064	<b>643-1064</b>
VT700C Shadow	84-87	VL-1040	<b>643-1040</b>
CB750 Nighthawk 750	91-93	VL-1050	<b>643-1050</b>
CB750 Nighthawk 750	95-03	VL-1050	<b>643-1050</b>
CB750A Automatic	76-78	VL-1001	<b>643-1001</b>
CB750C Custom	80-82	VL-1002	<b>643-1002</b>
CB750F Super Sport	75-78	VL-1001	<b>643-1001</b>
CB750F Super Sport	79-82	VL-1002	<b>643-1002</b>
CB750K0/K1-K5 750 Four	69-75	VL-1001	<b>643-1001</b>
CB750K 750 Four	76-78	VL-1001	<b>643-1001</b>
CB750K	79-82	VL-1002	<b>643-1002</b>
CB750L LTD	1979	VL-1002	<b>643-1002</b>
CB750SC Nighthawk	82-83	VL-1002	<b>643-1002</b>
VF750C V45 Magna	82-83	VL-1021	<b>643-1021</b>
VF750C V45 Magna	1988	VL-1021	<b>643-1021</b>
VF750C Magna	94-03	VL-1064	<b>643-1064</b>
VF750CD Magna Deluxe	95-96	VL-1064	<b>643-1064</b>
VF750C2 Magna Deluxe	97-00	VL-1064	<b>643-1064</b>
VF750F V45 Interceptor	83-84	VL-1021	<b>643-1021</b>
VF750S V45 Sabre	82-83	VL-1021	<b>643-1021</b>
VFR750R	90-97	VL-1064	<b>643-1064</b>
VFR750R (RC30)	1990	VL-1064	<b>643-1064</b>
VT750C Shadow	98-00	VL-1071	<b>643-1071</b>
VT750CD Shadow Deluxe	98-01	VL-1071	<b>643-1071</b>
VT750CD2 Shadow Deluxe	98-01	VL-1071	<b>643-1071</b>

### Honda Street

Model	Year	Vesrah Ref	Order No.
PC800 Pacific Coast	89-90	VL-1040	<b>643-1040</b>
PC800 Pacific Coast	94-98	VL-1040	<b>643-1040</b>
VT800C Shadow	1988	VL-1040	<b>643-1040</b>
CB900C Custom	80-82	VL-1002	<b>643-1002</b>
CB900F Super Sport	81-82	VL-1002	<b>643-1002</b>
CB900F (919)	02-05	VL-1083	<b>643-1083</b>
CBR900RR	93-99	VL-1083	<b>643-1083</b>
CB1000C Custom	1983	VL-1002	<b>643-1002</b>
CBR1000F Hurricane	87-88	VL-1077	<b>643-1077</b>
CBR1000F Hurricane	90-91	VL-1077	<b>643-1077</b>
GL1000 Goldwing	75-79	VL-1039	<b>643-1039</b>
GL1000L Goldwing LTD	1976	VL-1039	<b>643-1039</b>
VF1000F Interceptor	1984	VL-1021	<b>643-1021</b>
VF1000R	85-86	VL-1021	<b>643-1021</b>
CB1100F Super Sport	1983	VL-1002	<b>643-1002</b>
GL1100 Goldwing	80-83	VL-1032	<b>643-1032</b>
GL1100A Goldwing Aspencade	82-83	VL-1032	<b>643-1032</b>
GL1100I Goldwing Interstate	80-83	VL-1032	<b>643-1032</b>
ST1100	91-02	VL-1090	<b>643-1090</b>
ST1100A (ABS)	92-02	VL-1090	<b>643-1090</b>
VF1100C V65 Magna	83-86	VL-1058	<b>643-1058</b>
VF1100S V65 Sabre	84-85	VL-1058	<b>643-1058</b>
VT1100C Shadow	85-90	VL-1060	<b>643-1060</b>
GL1200 Goldwing	1984	VL-1066	<b>643-1066</b>
GL1200A Goldwing Aspencade	84-87	VL-1066	<b>643-1066</b>
GL1200I Goldwing Interstate	84-87	VL-1066	<b>643-1066</b>
GL1200L Goldwing LTD	1985	VL-1066	<b>643-1066</b>
GL1200SEi Goldwing	1986	VL-1066	<b>643-1066</b>
GL1500 Goldwing	88-90	VL-1081	<b>643-1081</b>
GL1500A Goldwing Aspencade	91-00	VL-1081	<b>643-1081</b>
GL1500C Valkyrie	97-00	VL-1081	<b>643-1081</b>
GL1500C Valkyrie	2003	VL-1081	<b>643-1081</b>
GL1500CD Valkyrie	01-03	VL-1081	<b>643-1081</b>
GL1500CF Valkyrie Interstate	99-01	VL-1081	<b>643-1081</b>
GL1500CT Valkyrie Tourer	97-00	VL-1081	<b>643-1081</b>
GL1500I Goldwing Interstate	91-96	VL-1081	<b>643-1081</b>
GL1500SE Goldwing SE	90-00	VL-1081	<b>643-1081</b>

### Honda ATV

ATC110	81-85	VL-1023	<b>643-1023</b>
ATC125M	84-85	VL-1023	<b>643-1023</b>
TRX125 Fourtrax	85-86	VL-1023	<b>643-1023</b>
ATC185	1980	VL-1016	<b>643-1016</b>
ATC185S	81-83	VL-1016	<b>643-1016</b>
ATC200	81-83	VL-1016	<b>643-1016</b>
ATC200E Big Red	82-83	VL-1016	<b>643-1016</b>
ATC200ES Big Red	1984	VL-1016	<b>643-1016</b>
ATC200M	84-85	VL-1016	<b>643-1016</b>
ATC200S	84-86	VL-1016	<b>643-1016</b>
ATC200X	83-85	VL-1016	<b>643-1016</b>
ATC200X	86-87	VL-1059	<b>643-1059</b>
TRX200 Fourtrax 200	1984	VL-1016	<b>643-1016</b>
ATC250R	85-86	VL-1030	<b>643-1030</b>
TRX250R Fourtrax 250R	86-89	VL-1030	<b>643-1030</b>
TRX300 Four Trax 300	88-00	VL-1072	<b>643-1072</b>
TRX300EX Four Trax 300EX	93-00	VL-1087	<b>643-1087</b>
TRX300EX Sportrax 300EX	01-08	VL-1087	<b>643-1087</b>
TRX300FW Four Trax 300 4x4	1988	VL-1072	<b>643-1072</b>
TRX300FW Four Trax 300 4x4	90-00	VL-1072	<b>643-1072</b>
TRX400EX Fourtrax 400EX	99-00	VL-1088	<b>643-1088</b>
TRX400EX Sportrax 400EX	01-07	VL-1088	<b>643-1088</b>

## Honda Dual Sport & Offroad

Model	Year	Vesrah Ref	Order No.
CRF50F	04-08	VL-1020	<b>643-1020</b>
XR50R	00-03	VL-1020	<b>643-1020</b>
CRF70F	04-08	VL-1020	<b>643-1020</b>
XL70K0/K1	74-75	VL-1020	<b>643-1020</b>
XL70	1976	VL-1020	<b>643-1020</b>
XL75	77-79	VL-1026	<b>643-1026</b>
XR75	77-78	VL-1026	<b>643-1026</b>
CR80R	84-85	VL-1037	<b>643-1037</b>
CR80R	86-02	VL-1053	<b>643-1053</b>
CR80RB	00-02	VL-1053	<b>643-1053</b>
CRF80F	04-08	VL-1026	<b>643-1026</b>
XL80S	80-85	VL-1026	<b>643-1026</b>
XR80	79-84	VL-1026	<b>643-1026</b>
XR80R	85-88	VL-1026	<b>643-1026</b>
XR80R	90-91	VL-1026	<b>643-1026</b>
XR80R	93-03	VL-1026	<b>643-1026</b>
CR85R	03-07	VL-1053	<b>641-1053</b>
CR85RB	03-07	VL-1053	<b>641-1053</b>
CRF100F	04-08	VL-1026	<b>643-1026</b>
XL100K0/K1	74-75	VL-1018	<b>643-1018</b>
XL100	76-78	VL-1018	<b>643-1018</b>
XL100S	79-85	VL-1026	<b>643-1026</b>
XR100	81-84	VL-1026	<b>643-1026</b>
XR100R	85-03	VL-1026	<b>643-1026</b>
CT110 Trail 110	80-84	VL-1023	<b>643-1023</b>
CT110 Trail 110	1986	VL-1023	<b>643-1023</b>
CR125R	84-86	VL-1043	<b>643-1043</b>
CR125R	90-99	VL-1074	<b>643-1074</b>
XL125S	79-82	VL-1016	<b>643-1016</b>
XL125S	1984	VL-1016	<b>643-1016</b>
XL185S	79-83	VL-1016	<b>643-1016</b>
XR185	1979	VL-1016	<b>643-1016</b>
TLR200 Reflex	86-87	VL-1016	<b>643-1016</b>
TR200 Fatcat	86-87	VL-1059	<b>643-1059</b>
XL200R	83-84	VL-1016	<b>643-1016</b>
XR200	80-84	VL-1016	<b>643-1016</b>
XR200R	81-88	VL-1016	<b>643-1016</b>
XR200R	90-91	VL-1078	<b>643-1078</b>
XR200R	94-02	VL-1078	<b>643-1078</b>
CR250R	85-87	VL-1046	<b>643-1046</b>
CR250R	92-01	VL-1085	<b>643-1085</b>
XL250R	82-83	VL-1009	<b>643-1009</b>
XL250R	84-87	VL-1047	<b>643-1047</b>
XL250S	79-81	VL-1009	<b>643-1009</b>
XR250L	91-96	VL-1047	<b>643-1047</b>
XR250R	81-82	VL-1009	<b>643-1009</b>
XR250R	84-94	VL-1047	<b>643-1047</b>
XR250R	96-04	VL-1086	<b>643-1086</b>
SL350K0/K1/K2 Motosport	70-72	VL-1013	<b>643-1013</b>
XR400R	96-04	VL-1088	<b>643-1088</b>
CR500R	85-01	VL-1054	<b>643-1054</b>
XL500S	79-81	VL-1009	<b>643-1009</b>
XL500R	1982	VL-1009	<b>643-1009</b>
XR500	79-80	VL-1009	<b>643-1009</b>
XR500R	81-82	VL-1009	<b>643-1009</b>
XR500R	83-84	VL-1028	<b>643-1028</b>
XL600R	83-87	VL-1028	<b>643-1028</b>
XR600R	85-00	VL-1028	<b>643-1028</b>
NX650	88-89	VL-1028	<b>643-1028</b>
XR650L	93-08	VL-1028	<b>643-1028</b>

## Kawasaki Street

KZ400B1/B2	78-79	VL-4025	<b>643-4025</b>
KZ400C1	1978	VL-4025	<b>643-4025</b>
KZ400H1 LTD	1979	VL-4025	<b>643-4025</b>
KZ440A1/A2/A3/A4 LTD	80-83	VL-4025	<b>643-4025</b>
KZ440B1/B2	80-81	VL-4025	<b>643-4025</b>
KZ440D1/D2/D3/D4/D5 LTD Belt	80-83	VL-4025	<b>643-4025</b>

## Kawasaki Street

Model	Year	Vesrah Ref	Order No.
KZ440G1 Belt	1982	VL-4025	<b>643-4025</b>
EN450A1-A6 LTD 454	85-90	VL-4039	<b>643-4039</b>
EN500A1-A7 Vulcan 500	90-96	VL-4039	<b>643-4039</b>
EN500C1-C10 Vulcan 500 LTD	96-05	VL-4039	<b>643-4039</b>
EN500C6F/C7F/C8F Vulcan 500 LTD	06-08	VL-4039	<b>643-4039</b>
EX500A1-A7	87-93	VL-4039	<b>643-4039</b>
EX500D1/D2/D3 Ninja 500	94-96	VL-4039	<b>643-4039</b>
EX500D4-D12 Ninja 500R	97-05	VL-4039	<b>643-4039</b>
EX500D6F/D7F/D8F Ninja 500R	06-08	VL-4039	<b>643-4039</b>
KZ550A1/A2/A3/A4	80-83	VL-4024	<b>643-4024</b>
KZ550C1/C2/C3/C4 LTD	80-83	VL-4024	<b>643-4024</b>
KZ550D1 GPz	1981	VL-4024	<b>643-4024</b>
KZ550F1 Spectre	1983	VL-4024	<b>643-4024</b>
KZ550F2 LTD	1984	VL-4024	<b>643-4024</b>
KZ550H1/H2 GPz	82-83	VL-4024	<b>643-4024</b>
KZ550M1 LTD	1983	VL-4024	<b>643-4024</b>
ZR550B1/B2/B3/B4 Zephyr	90-93	VL-4024	<b>643-4024</b>
ZX550A1/A2/A3 GPz	84-86	VL-4024	<b>643-4024</b>
KL600A1 KLR600	1984	VL-4013	<b>643-4013</b>
KL600B1/B2 KLR600	85-86	VL-4013	<b>643-4013</b>
ZL600A1/A2 Eliminator	86-87	VL-4035	<b>643-4035</b>
ZL600B2/B3 Eliminator	96-97	VL-4035	<b>643-4035</b>
ZX600A1/A2/A3 Ninja 600R	85-87	VL-4035	<b>643-4035</b>
ZX600B1 Ninja 600RX	1987	VL-4035	<b>643-4035</b>
ZX600C1-C10 Ninja 600R	88-97	VL-4035	<b>643-4035</b>
KL650A1-A19 KLR650	87-05	VL-4013	<b>643-4013</b>
KL650A6F/A7F KLR650	06-07	VL-4013	<b>643-4013</b>
KL650B2/B3 Tengai KLR650	90-91	VL-4013	<b>643-4013</b>
KZ650B1/B2/B2A/B3	77-79	VL-4005	<b>643-4005</b>
KZ650C1/C2/C3 Custom	77-79	VL-4005	<b>643-4005</b>
KZ650D1/D1A/D2 SR	78-79	VL-4005	<b>643-4005</b>
KZ650E1 LTD	1980	VL-4005	<b>643-4005</b>
KZ650F1	1980	VL-4005	<b>643-4005</b>
KZ650H1/H2/H3 CSR	81-83	VL-4005	<b>643-4005</b>
KZ700A1	1984	VL-4005	<b>643-4005</b>
ZN700A1/A2 LTD	84-85	VL-4005	<b>643-4005</b>
KZ750B1/B2/B3/B4 2-cylinder	76-79	VL-4002	<b>643-4002</b>
KZ750E1/E2/E3	80-82	VL-4005	<b>643-4005</b>
KZ750F1/F2 Spectre & LTD	83-84	VL-4005	<b>643-4005</b>
KZ750G1 LTD 2-cylinder	1980	VL-4002	<b>643-4002</b>
KZ750H1/H2/H3/H4 LTD	80-83	VL-4005	<b>643-4005</b>
KZ750K1/K2 2-cylinder	83-84	VL-4002	<b>643-4002</b>
KZ750L3	1983	VL-4005	<b>643-4005</b>
KZ750M1 CSR 2-cylinder	1983	VL-4002	<b>643-4002</b>
KZ750N1/N2 Spectre	82-83	VL-4005	<b>643-4005</b>
KZ750R1 GPz	1982	VL-4005	<b>643-4005</b>
ZX750A1/A2/A3 GPz	83-85	VL-4005	<b>643-4005</b>
ZX750E1/E2 GPz Turbo	84-85	VL-4005	<b>643-4005</b>
KZ900A4/A5	76-77	VL-4001	<b>643-4001</b>
KZ900B1 LTD	1976	VL-4001	<b>643-4001</b>
Z1/Z1A/Z1B-900	73-75	VL-4001	<b>643-4001</b>
ZL900A1/A2 Eliminator	85-86	VL-4014	<b>643-4014</b>
ZX900A1/A2/A3 Ninja 900R	84-86	VL-4014	<b>643-4014</b>
KZ1000A1/A2	77-78	VL-4001	<b>643-4001</b>
KZ1000A3/A3A/A4 MKII	79-80	VL-4001	<b>643-4001</b>
KZ1000B1/B2/B3/B4 LTD	77-80	VL-4001	<b>643-4001</b>
KZ1000C1/C1A/C2/C3/C4 Police	78-81	VL-4001	<b>643-4001</b>
KZ1000D1 Z1R	1978	VL-4001	<b>643-4001</b>
KZ1000D3 Z1R	1980	VL-4001	<b>643-4001</b>
KZ1000E1/E2 Shaft ST	79-80	VL-4001	<b>643-4001</b>
KZ1000G1 Classic LTD	1980	VL-4001	<b>643-4001</b>
KZ1000J1/J2/J3	81-83	VL-4004	<b>643-4004</b>
KZ1000K1/K2 LTD	81-82	VL-4004	<b>643-4004</b>
KZ1000M1/M2 CSR	81-82	VL-4004	<b>643-4004</b>
KZ1000P1-P21 Police	82-02	VL-4004	<b>643-4004</b>
KZ1000R1/R2 Replica	82-83	VL-4004	<b>643-4004</b>
ZG1000A1-A14 Concours	86-99	VL-4014	<b>643-4014</b>
ZG1000A15-20 Concours	00-05	VL-4054	<b>643-4054</b>
ZG1000A6F Concours	2006	VL-4054	<b>643-4054</b>

# Clutch Cover Gaskets

## Kawasaki Street

Model	Year	Vesrah Ref	Order No.
ZL1000A1 Eliminator	1987	VL-4014	<b>643-4014</b>
ZX1000A1/A2 Ninja 1000R	86-87	VL-4014	<b>643-4014</b>
ZX1000B1/B2/B3 Ninja ZX-10	88-90	VL-4014	<b>643-4014</b>
KZ1100A1/A2/A3 Shaft	81-83	VL-4004	<b>643-4004</b>
KZ1100B1/B2 GPz	81-82	VL-4004	<b>643-4004</b>
KZ1100D1/D2 Spectre	82-83	VL-4004	<b>643-4004</b>
KZ1100L1 LTD	1983	VL-4004	<b>643-4004</b>
ZN1100B1/B2 LTD	84-85	VL-4004	<b>643-4004</b>
ZR1100C3/C4 ZRX1100	99-00	VL-4014	<b>643-4014</b>
ZX1100A1/A2 GPz	83-84	VL-4004	<b>643-4004</b>
ZX1100C1/C2/C3/C4 Ninja ZX-11	90-93	VL-4014	<b>643-4014</b>
ZX1100D1-D9 Ninja ZX-11	93-01	VL-4014	<b>643-4014</b>
ZX1100E1/E2/E3 GPz	95-97	VL-4014	<b>643-4014</b>
ZX1100F1 GPz (ABS)	1996	VL-4014	<b>643-4014</b>
ZG1200A1 Voyager XII	1986	VL-4051	<b>643-4051</b>
ZG1200B1-B17 Voyager XII	87-03	VL-4051	<b>643-4051</b>
ZR1200A1/A2/A3/A4/A5 ZRX1200	01-05	VL-4054	<b>643-4054</b>
ZX1200C1/C2/C3/C4 ZZR1200	02-05	VL-4054	<b>643-4054</b>

## Kawasaki ATV

Model	Year	Vesrah Ref	Order No.
KLF220A1-A15 Bayou 220	88-02	VL-4042	<b>643-4042</b>
KLF250A1/A2/A3/A6F/A7F Bayou	03-07	VL-4042	<b>643-4042</b>
KSF250A1-A17 Mojave	87-03	VL-4040	<b>643-4040</b>
KSF250A18 KFX250 Mojave	2004	VL-4040	<b>643-4040</b>
KXT250A1/A2 Tecate 3	84-85	VL-4012	<b>643-4012</b>
KXT250B1/B2 Tecate 3	86-87	VL-4030	<b>643-4030</b>
KEF300A1-A6 Lakota 300	95-00	VL-4036	<b>643-4036</b>
KEF300B1/B2/B3 Lakota Sport	01-03	VL-4036	<b>643-4036</b>
KLF300A1/A2 Bayou 300	86-87	VL-4036	<b>643-4036</b>
KLF300B1-B17 Bayou 300	88-04	VL-4036	<b>643-4036</b>
KLF300C1-C16 Bayou 300 4x4	89-04	VL-4043	<b>643-4043</b>

## Kawasaki Dual Sport & Offroad

Model	Year	Vesrah Ref	Order No.
KX60A1/A2	83-84	VL-4020	<b>643-4020</b>
KX60B1-B19	85-03	VL-4020	<b>643-4020</b>
KDX80B2/B3	82-83	VL-4020	<b>643-4020</b>
KDX80C1/C2/C3/C4/C5	84-88	VL-4020	<b>643-4020</b>
KX80C1/C2	81-82	VL-4020	<b>643-4020</b>
KX80E1/E2/E3	83-85	VL-4020	<b>643-4020</b>
KX80G1/G2	86-87	VL-4032	<b>643-4032</b>
KX80J2	1987	VL-4032	<b>643-4032</b>
KX80L1/L2/L3	88-90	VL-4032	<b>643-4032</b>
KX80N1/N2/N3	88 90	VL-4032	<b>643-4032</b>
KX80R1/R2/R3/R4/R5/R6/R7	91-97	VL-4032	<b>643-4032</b>
KX80T1/T2/T3/T4	91-94	VL-4032	<b>643-4032</b>
KX80W1/W2/W3 (inner)	98-00	VL-4032	<b>643-4032</b>
KX85A1/A2/A3/A4/A5 (inner)	01-05	VL-4032	<b>643-4032</b>
KX85A6F/A7F (inner)	06-07	VL-4032	<b>643-4032</b>
KX100B5/B6/B7	95-97	VL-4032	<b>643-4032</b>
KX100C1/C2/C3 (inner)	98-00	VL-4032	<b>643-4032</b>
KX100D1/D2/D3/D4/D5 (inner)	01-05	VL-4032	<b>643-4032</b>
KX100D6F/D7F (inner)	06-07	VL-4032	<b>643-4032</b>
KX125F1/G1	88-89	VL-4046	<b>643-4046</b>
KX125H1/H2	90-91	VL-4046	<b>643-4046</b>
KX125K1/K2/K3/K4/K5 (inner)	94-98	VL-4055	<b>643-4055</b>
KX125L1/L2/L3/L4 (inner)	99-02	VL-4055	<b>643-4055</b>
KDX200C1/C2/C3	86-88	VL-4037	<b>643-4037</b>
KDX200H1-H11	95-05	VL-4037	<b>643-4037</b>
KDX200H6F	2006	VL-4037	<b>643-4037</b>
KDX220A4-A12	97-05	VL-4037	<b>643-4037</b>
KX250D1/D2	85-86	VL-4030	<b>643-4030</b>
KX250E1/F1/G1/H1/H2 (inner)	87-91	VL-4049	<b>643-4049</b>
KX250K1/K2/K3/K4/K5 (inner)	94-98	VL-4056	<b>643-4056</b>
KX250K1/K2/K3/K4/K5 (outer)	94-98	VL-4057	<b>643-4057</b>
KX250L1/L2/L3/L4 (inner)	99-02	VL-4056	<b>643-4056</b>
KX250L1/L2/L3/L4 (outer)	99-02	VL-4057	<b>643-4057</b>
KX250M1/M2 (inner)	03-04	VL-4056	<b>643-4056</b>
KX250M1/M2 (outer)	03-04	VL-4057	<b>643-4057</b>

## Kawasaki Dual Sport & Offroad

Model	Year	Vesrah Ref	Order No.
KX500B1/C1/D1	86-88	VL-4034	<b>643-4034</b>
KX500E1-E16	89-04	VL-4034	<b>643-4034</b>
KL600A1 KLR600	1984	VL-4013	<b>643-4013</b>
KL600B1/B2 KLR600	85-86	VL-4013	<b>643-4013</b>
KL650A10-A19 KLR650	87-05	VL-4013	<b>643-4013</b>
KL650A6F/A7F KLR650	06-07	VL-4013	<b>643-4013</b>
KL650B2/B3 Tengai KLR650	90-91	VL-4013	<b>643-4013</b>

## Suzuki Street

Model	Year	Vesrah Ref	Order No.
GS450ET/EX/EZ/ED	80-83	VL-3006	<b>643-3006</b>
GS450LT/LX/LZ/LD	80-83	VL-3006	<b>643-3006</b>
GS450LF/LG/LH/LJ	85-88	VL-3006	<b>643-3006</b>
GS450ST/SX	80-81	VL-3006	<b>643-3006</b>
GS450TX/TZ	81-82	VL-3006	<b>643-3006</b>
GS450TX/TZ/TXZ/TXD	81-83	VL-3006	<b>643-3006</b>
GS500EK-EY	89-00	VL-3006	<b>643-3006</b>
GS500EK1/EK2	01-02	VL-3006	<b>643-3006</b>
GS500FK4/FK5/FK6/FK7	04-07	VL-3006	<b>643-3006</b>
GSF600ST-SK3 Bandit	96-03	VL-3039	<b>643-3039</b>
GSX600FJ-FK6 Katana	88-06	VL-3039	<b>643-3039</b>
GSX-R600VNW/WP	92-93	VL-3070	<b>643-3070</b>
RF600RR/RS/RT	94-96	VL-3070	<b>643-3070</b>
GS700EF/ESF	1985	VL-3016	<b>643-3016</b>
GS750B/C/EC/N/EN/LN	77-79	VL-3001	<b>643-3001</b>
GS750ET/EX/EZ	80-83	VL-3007	<b>643-3007</b>
GS750ED/ESD	1983	VL-3016	<b>643-3016</b>
GS750LT/LX	80-81	VL-3007	<b>643-3007</b>
GS750SD Katana	1983	VL-3007	<b>643-3007</b>
GS750TZ/TD	82-83	VL-3007	<b>643-3007</b>
GSX750FK-FK5 Katana	89-05	VL-3039	<b>643-3039</b>
GSX-R750G/H/J/K/L/M/N	86-92	VL-3039	<b>643-3039</b>
GSX-R750RG	1986	VL-3039	<b>643-3039</b>
GSX-R750WP/WR/WS	93-95	VL-3070	<b>643-3070</b>
VS800GLN-GLK4 Intruder	92-04	VL-3065	<b>643-3065</b>
VS800 Boulevard S50	05-06	VL-3065	<b>643-3065</b>
VX800L/M/N/P	90-93	VL-3065	<b>643-3065</b>
GS850GN/GT/GLT/GX/GLX	79-81	VL-3001	<b>643-3001</b>
GS850GZ/GLZ/GD/GLD	82-83	VL-3009	<b>643-3009</b>
RF900RR/RS/RZS/RT/RV/	94-97	VL-3070	<b>643-3070</b>
GS1000C/EC/N	78-79	VL-3002	<b>643-3002</b>
GS1000EN/ET	80-81	VL-3002	<b>643-3002</b>
GS1000GT/GX/GZ/GD	80-83	VL-3009	<b>643-3009</b>
GS1000GLT/GLX/GLZ/GLD	80-83	VL-3009	<b>643-3009</b>
GS1000LN	1979	VL-3009	<b>643-3009</b>
GS1000SN/ST	79-80	VL-3002	<b>643-3002</b>
GS1000SZ Katana	1983	VL-3008	<b>643-3008</b>
GS1100ET/EX/EZ/ED/ESD	80-83	VL-3008	<b>643-3008</b>
GS1100GKZ/GK2/GKD/GKE	82-84	VL-3009	<b>643-3009</b>
GS1100LT	1980	VL-3008	<b>643-3008</b>
GS1100SD Katana	1983	VL-3008	<b>643-3008</b>
GSX1100FJ-FP Katana	88-93	VL-3039	<b>643-3039</b>
GSX1100GM/GN/GP Shaft	91-93	VL-3039	<b>643-3039</b>
GSX-R1100G/H/J/K/L/M/N	86-92	VL-3039	<b>643-3039</b>
GSX-R1100WP/WR/WS/WT/WV/WWW	93-98	VL-3070	<b>643-3070</b>
GS1150ES3/EF/EF2/ESE/ESF	83-85	VL-3008	<b>643-3008</b>
GS1150EG/ESG	1986	VL-3008	<b>643-3008</b>
GSF1200SVSW/SX/SY Bandit	97-00	VL-3039	<b>643-3039</b>
GSF1200SAV Bandit	1997	VL-3039	<b>643-3039</b>
GSF1200SK1-SK5 Bandit	01-05	VL-3039	<b>643-3039</b>
VS1400GLPH-GLPY Intruder	87-00	VL-3066	<b>643-3066</b>
VS1400GLPK1-GLPK4 Intruder	01-04	VL-3066	<b>643-3066</b>
VS1400 Boulevard S83	05-06	VL-3066	<b>643-3066</b>
VL1500W-K4 Intruder 1500 LC	98-04	VL-3066	<b>643-3066</b>



## Suzuki ATV

Model	Year	Vesrah Ref	Order No.
LT80H-Y Quadrunner	87-00	VL-3056	<b>643-3056</b>
LT80K1/K2/K3/K4 Quadport	01-04	VL-3056	<b>643-3056</b>
LT-F160T/V/W/X/Y/K1	96-01	VL-3033	<b>643-3033</b>
LT-F160K3	2003	VL-3033	<b>643-3033</b>
LT230EH/EJ/EK/EL Quadrunner	87-90	VL-3033	<b>643-3033</b>
LT230EM/EN/EP Quadrunner	91-93	VL-3033	<b>643-3033</b>
LT230GEF/GEG Quadrunner	85-86	VL-3033	<b>643-3033</b>
LT230SF/SG/SH/SJ Quadport	85-88	VL-3034	<b>643-3034</b>
LT-F230G/H Quadrunner	86-87	VL-3033	<b>643-3033</b>
LT250RF/RG Quadracer	85-86	VL-3036	<b>643-3036</b>
LT250RH-RN Quadracer	87-92	VL-3060	<b>643-3060</b>
LT-4WDH/J/K/L/M/N/P/R/S/T	87-96	VL-3040	<b>643-3040</b>
LT-4WDV/WDW Quadrunner 250	97-98	VL-3040	<b>643-3040</b>
LT-F250J/K/L/M/N/P	88-93	VL-3040	<b>643-3040</b>
LT-F250R/S/T/V/W/X/Y/K1	94-01	VL-3040	<b>643-3040</b>
LT-F250FX/FY/FK1/FK2 Quadrunner	99-02	VL-3040	<b>643-3040</b>
LT300EH/EJ/EK	87-89	VL-3035	<b>643-3035</b>
LT-F300FX/FY/FK1/FK2 King Quad	99-02	VL-3040	<b>643-3040</b>
LT-F4WDXM/N/P/R King Quad	91-94	VL-3040	<b>643-3040</b>
LT-F4WDXS/T/V/W King Quad	95-98	VL-3040	<b>643-3040</b>
LT500RH/RJ/RK/RL Quadracer	87-90	VL-3067	<b>643-3067</b>

## Suzuki Dual Sport & Offroad

RM60K3	2003	VL-4020	<b>643-4020</b>
RM125G	1986	VL-3044	<b>643-3044</b>
RM125L/M (inner)	90-91	VL-3055	<b>643-3055</b>
RM125N/P/R/S/T (inner)	92-96	VL-3074	<b>643-3074</b>
RM250G	1986	VL-3045	<b>643-3045</b>
RM250J	1988	VL-3058	<b>643-3058</b>
RM250K/L/MN/P (inner)	89-93	VL-3059	<b>643-3059</b>
RM250R/S	94-95	VL-3075	<b>643-3075</b>
DR250L/M/N/P Offroad	90-93	VL-3064	<b>643-3064</b>
DR250SL/SM/SN	90-92	VL-3064	<b>643-3064</b>
DR250SEP/SER Dual Sport	93-94	VL-3069	<b>643-3069</b>
DR250SES Dual Sport	1995	VL-3069	<b>643-3069</b>
DR350L/M/N/P/R Offroad	90-94	VL-3064	<b>643-3064</b>
DR350S/T/V/W/X Offroad	95-99	VL-3069	<b>643-3069</b>
DR350SL/SM/SN/SP	90-93	VL-3064	<b>643-3064</b>
DR350SER-SEX Dual Sport	94-99	VL-3069	<b>643-3069</b>
DR650SL/SM/SN/SP	90-93	VL-3068	<b>643-3068</b>
DR650SER/SES	94-95	VL-3068	<b>643-3068</b>

## Yamaha Street

RX50K	1983	VL-2024	<b>643-2024</b>
RX50MK Midnight	1983	VL-2024	<b>643-2024</b>
YRS50T/U/W/A/B/D	87-92	VL-2024	<b>643-2024</b>
RD125LC Watercooled (Europe)	82-84	VL-2030	<b>643-2030</b>
TW200T/TC-W Trailway	87-07	VL-2012	<b>643-2012</b>
XT225D/DC-W1/WC Serrow	92-07	VL-2012	<b>643-2012</b>
RD250LC Watercooled (Europe)	80-82	VL-2011	<b>643-2011</b>
XT250L/LC Dual Sport	1984	VL-2037	<b>643-2037</b>
RD350LC Watercooled (Europe)	80-85	VL-2011	<b>643-2011</b>
RZ350L/N/NC/NCII	84-85	VL-2011	<b>643-2011</b>
XT350N/NC-M/MC Dual Sport	85-00	VL-2037	<b>643-2037</b>
FZR400U/SUC/W/SWC/A/SAC	88-90	VL-2052	<b>643-2052</b>
SR500E/F/G/H	78-81	VL-2003	<b>643-2003</b>
XJ550H/J/K Maxim	81-83	VL-2006	<b>643-2006</b>
XJ550RH/RJ/RK Seca	81-83	VL-2006	<b>643-2006</b>
XT550J/K Dual Sport	82-83	VL-2013	<b>643-2013</b>
FJ600L/LC/N/NC	84-85	VL-2006	<b>643-2006</b>
FZ600S/SC/T/TC/U/UC	86-88	VL-2006	<b>643-2006</b>
FZR600W/WC/AC	89-90	VL-2052	<b>643-2052</b>
FZR600RA/RAC-RL/RLC	90-99	VL-2052	<b>643-2052</b>
SRX600S/SC	1986	VL-2013	<b>643-2013</b>

## Yamaha Street

Model	Year	Vesrah Ref	Order No.
XJ600SD/SDC-SK/SKC Seca II	92-98	VL-2057	
XT600L/LC-EG/EGC Dual Sport	84-95	VL-2013	<b>643-2013</b>
YX600S/SC-A/AC Radian	86-90	VL-2006	<b>643-2006</b>
XJ650G/H/J/K Maxim	80-83	VL-2022	<b>643-2022</b>
XJ650LH Midnight Maxim	1981	VL-2022	<b>643-2022</b>
XJ650LJ/LK Seca Turbo	82-83	VL-2022	<b>643-2022</b>
XJ650RJ Seca	1982	VL-2022	<b>643-2022</b>
XS1-650	1970	VL-2002	<b>643-2002</b>
XS1B-650	1971	VL-2002	<b>643-2002</b>
XS2-650	1972	VL-2002	<b>643-2002</b>
TX650/A	73-74	VL-2002	<b>643-2002</b>
XS650B/C/D/E/F	75-79	VL-2002	<b>643-2002</b>
XS6502F	1979	VL-2002	<b>643-2002</b>
XS650SE/SF Special	78-79	VL-2002	<b>643-2002</b>
XS650G/H Special II	80-81	VL-2002	<b>643-2002</b>
XS650SG/SH Special	80-81	VL-2002	<b>643-2002</b>
XS650SJ/SK Heritage Special	82-83	VL-2002	<b>643-2002</b>
FZ700T/TC	1987	VL-2045	<b>643-2045</b>
FZX700S/SC/T/TC Fazer	86-87	VL-2045	<b>643-2045</b>
XV700L/LC/N/NC Virago	84-85	VL-2005	<b>643-2005</b>
XV700CS/CSC/CT/CTC Virago	86-87	VL-2005	<b>643-2005</b>
XV700SS/SSC Virago	1986	VL-2005	<b>643-2005</b>
FZ750N/S/SC	85-86	VL-2045	<b>643-2045</b>
FZ750U/UC	1988	VL-2045	<b>643-2045</b>
FZR750RT/RU	87-88	VL-2045	<b>643-2045</b>
XS750D/2D/E/F	77-79	VL-2004	<b>643-2004</b>
XS750SE/SF Special	78-79	VL-2004	<b>643-2004</b>
XJ750J/K Maxim	82-83	VL-2022	<b>643-2022</b>
XJ750MK Midnight Maxim	1983	VL-2022	<b>643-2022</b>
XJ750RH/RJ/RK Seca	81-83	VL-2022	<b>643-2022</b>
XV750H/J/K Virago	81-83	VL-2005	<b>643-2005</b>
XXV750MK Midnight Virago	1983	VL-2005	<b>643-2005</b>
XV750U/UC-K/KC Virago	88-98	VL-2005	<b>643-2005</b>
YZF750RF/RFC	1994	VL-2045	<b>643-2045</b>
YZF750RH/RHC/RJ/RJC/RK/RKC	96-98	VL-2045	<b>643-2045</b>
XS850G/H	80-81	VL-2004	<b>643-2004</b>
XS850LG/LH Special	80-81	VL-2004	<b>643-2004</b>
XS850sG/SH Midnight Special	80-81	VL-2004	<b>643-2004</b>
XJ900RKSeca	1983	VL-2022	<b>643-2022</b>
XV920J/K Virago	82-83	VL-2005	<b>643-2005</b>
XV920MK Midnight Virago	1983	VL-2005	<b>643-2005</b>
XV920RH/RJ	81-82	VL-2005	<b>643-2005</b>
XV1000L/LC/N/NC Virago	84-85	VL-2005	<b>643-2005</b>
FZR1000T/TC/U/UC/W/WC/A/AC	87-90	VL-2045	<b>643-2045</b>
FZR1000B/BC-G/GC	91-95	VL-2045	<b>643-2045</b>
YZF1000R/J/RJC	1997	VL-2045	<b>643-2045</b>
XJ1100J Maxim	1982	VL-2004	<b>643-2004</b>
XS1100E/F/G/H	78-81	VL-2004	<b>643-2004</b>
XS1100LG/LH Midnight Special	80-81	VL-2004	<b>643-2004</b>
XS1100SF/SG/SH Special	79-81	VL-2004	<b>643-2004</b>
XV1100S/SC-L/LC Virago	86-99	VL-2005	<b>643-2005</b>
XV1100SH-SK/SKC Virago	96-98	VL-2005	<b>643-2005</b>
FJ1200S/SC/T/TC	86-87	VL-2048	<b>643-2048</b>
FJ1200W/WC/A/AC/B/BC/D/DC	89-92	VL-2048	<b>643-2048</b>
FJ1200AD/ADC/AE/AEC (ABS)	92-93	VL-2048	<b>643-2048</b>

## Yamaha ATV

YF60S Moto-4	1986	VL-2015	<b>643-2015</b>
YT60L/N Tri-Zinger	84-85	VL-2015	<b>643-2015</b>
YFM200N Moto-4	1985	VL-2017	<b>643-2017</b>
YFM200DXS-DXW Moto-4	86-89	VL-2017	<b>643-2017</b>
YFS200U-V Blaster	88-06	VL-2030	<b>643-2030</b>
YFS200SEV Blaster	2006	VL-2030	<b>643-2030</b>
YTM200K/L/N Tri-Moto	83-85	VL-2017	<b>643-2017</b>
YTM200EK/EL/ERN Tri-Moto	83-85	VL-2017	<b>643-2017</b>
YFM225S/T/U Moto-4 (inner)	86-88	VL-2017	<b>643-2017</b>

# Clutch Cover Gaskets

## Yamaha ATV

Model	Year	Vesrah Ref	Order No.
YTM225DRN/DRS Tri-Moto	85-86	VL-2017	<b>643-2017</b>
YTM225DXK/DXL/DXN Tri-Moto	83-85	VL-2017	<b>643-2017</b>
YFB250D/E/F/G/H Timberwolf	92-96	VL-2017	<b>643-2017</b>
YFB250FWF/FWG Timberwolf	94-95	VL-2017	<b>643-2017</b>
YFB250FWH/FWJ Timberwolf	96-97	VL-2017	<b>643-2017</b>
YFB250FWK/FWL Timberwolf	98-99	VL-2017	<b>643-2017</b>
YFB250FWMFWM Timberwolf	2000	VL-2017	<b>643-2017</b>
YFB250UH/UJ/JUK Timberwolf	96-98	VL-2017	<b>643-2017</b>
YFM250W/A/B Moto-4	89-91	VL-2017	<b>643-2017</b>
YFM250M/MC Beartracker	2000	VL-2017	<b>643-2017</b>
YFM250BT/BV Bruin 250	05-06	VL-2017	<b>643-2017</b>
YFM250XS Beartracker	2004	VL-2017	<b>643-2017</b>
YFM350S Raptor	2004	VL-2041	<b>643-2041</b>
YFM350RSET/RSEV Raptor 350 SE	05-06	VL-2041	<b>643-2041</b>
YFM350RT/RV Raptor	05-06	VL-2041	<b>643-2041</b>
YFM350ERT/ERU/ERW/ERA Moto-4	87-90	VL-2041	<b>643-2041</b>
YFM350ERD/ERE/ERF/ERG Moto-4	92-95	VL-2041	<b>643-2041</b>
YFM350FWT-FWJ Big Bear 4WD	87-97	VL-2041	<b>643-2041</b>
YFM350UH/UJ/UK Big Bear	96-98	VL-2041	<b>643-2041</b>
YFM350XT-XS/XSC Warrior	87-04	VL-2041	<b>643-2041</b>
YFZ350T-V Banshee	87-06	VL-2011	<b>643-2011</b>
YFZ350LER Banshee Limited Ed.	2003	VL-2011	<b>643-2011</b>
YFZ350LES Banshee Limited Ed.	2004	VL-2011	<b>643-2011</b>
YFZ350RB Banshee Limited Ed.	2003	VL-2011	<b>643-2011</b>
YFZ350SET/SEV Banshee SE	05-06	VL-2011	<b>643-2011</b>
YFM400FWG/FWH Kodiak	95-96	VL-2041	<b>643-2041</b>
YFM400FWJ/FWK Kodiak	97-98	VL-2041	<b>643-2041</b>

## Yamaha Dual Sport & Offroad

PW50A-X Y-Zinger	90-08	VL-2015	<b>643-2015</b>
YZ50G	1980	VL-2024	<b>643-2024</b>
BW80U Big Wheel	1988	VL-2028	<b>643-2028</b>
BW80A Big Wheel	1990	VL-2028	<b>643-2028</b>
DT80H/J/K	81-83	VL-2024	<b>643-2024</b>
GT80A/B/C	74-76	VL-2024	<b>643-2024</b>
GTMX-80A/B/C/D/E/F	74-79	VL-2024	<b>643-2024</b>
MX80G/H/J	80-82	VL-2024	<b>643-2024</b>
PW80G-V Y-Zinger	95-06	VL-2028	<b>643-2028</b>

## Yamaha Dual Sport & Offroad

Model	Year	Vesrah Ref	Order No.
YZ80A/BC/D/E/F/G	74-80	VL-2024	<b>643-2024</b>
YZ80J/K/L/N/S/T/U/W/A/B/D	82-92	VL-2018	<b>643-2018</b>
YZ80F1/G1/H1/J1/K1/L1/M1/N1	93-01	VL-2059	<b>643-2059</b>
YZ85P/R/S/T/V (inner)	02-06	VL-2059	<b>643-2059</b>
XT125J/K/KC Dual Sport	82-83	VL-2012	<b>643-2012</b>
YZ125F1/G1/H1/J1/K1/L1 (inner)	94-99	VL-2054	<b>643-2054</b>
YZ125M1/N1/P/R/S1 (inner)	00-04	VL-2054	<b>643-2054</b>
BW200N/S Big Wheel	85-86	VL-2012	<b>643-2012</b>
BW200ES/ET/EUBig Wheel	86-88	VL-2012	<b>643-2017</b>
TW200U/UC-V/VVC Trailway	88-06	VL-2012	<b>643-2012</b>
XT200J/K/KC Dual Sport	82-83	VL-2012	<b>643-2012</b>
TT225S/T	86-87	VL-2012	<b>643-2012</b>
TT-R225L/LC-S/SC	99-04	VL-2012	<b>643-2012</b>
TT-R230T/TC/V/VVC	05-06	VL-2012	<b>643-2012</b>
XT225D/DC-V/VVC Serow	92-06	VL-2012	<b>643-2012</b>
IT250F/G/H/J/K	79-83	VL-2016	<b>643-2016</b>
WR250ZB/ZD/ZE/ZF (inner)	91-94	VL-2046	<b>643-2046</b>
WR250ZG/ZH/ZJ (inner)	95-97	VL-2046	<b>643-2046</b>
XT250/L/LC Dual Sport	1984	VL-2037	<b>643-2037</b>
YZ250G/H	80-81	VL-2016	<b>643-2016</b>
YZ250U/W	88-89	VL-2046	<b>643-2046</b>
YZ250A1/B1/D1/E1/F1/G1/H1 (inner)	90-96	VL-2046	<b>643-2046</b>
YZ250J1/K1 (inner)	97-98	VL-2064	<b>643-2064</b>
YZ250WRW/WRA (inner)	89-90	VL-2046	<b>643-2046</b>
TT350S/T Offroad	86-87	VL-2037	<b>643-2037</b>
XT350N/NC-M/MC Dual Sport	85-00	VL-2037	<b>643-2037</b>
IT465H/J	81-82	VL-2016	<b>643-2016</b>
YZ465G/H/J	80-82	VL-2016	<b>643-2016</b>
IT490K/L	83-84	VL-2016	<b>643-2016</b>
YZ490J/K/L/N/S/T/U/W/A	82-90	VL-2016	<b>643-2016</b>
TT500C/D/E/F/G/H	76-81	VL-2003	<b>643-2003</b>
WR500ZD/ZE	92-93	VL-2016	<b>643-2016</b>
XT500C/D/E/F/G/H Dual Sport	76-81	VL-2003	<b>643-2003</b>
XT550J/K Dual Sport	82-83	VL-2013	<b>643-2013</b>
TT600K/L/N/S Offroad	83-86	VL-2013	<b>643-2013</b>
XT600L/LC-EG/EGC Dual Sport	84-95	VL-2013	<b>643-2013</b>



## Sudco Part Number to OEM Cross Reference Clutch Cover Gaskets

### Honda

OEM Reference	Vesrah Ref	Order No.
11351-MN5-010	VL-1081	643-1081
11351-MN5-651	VL-1081	643-1081
11372-ME9-306	VL-1040	643-1040
11372-ME9-000	VL-1040	643-1040
11372-MG8-000	VL-1060	643-1060
11372-MM8-880	VL-1060	643-1060
11393-GBF-830	VL-1053	643-1053
11393-GC4-308	VL-1037	643-1037
11393-GC4-710	VL-1037	643-1037
11393-GC4-730	VL-1037	643-1037
11393-HB5-000	VL-1059	643-1059
11393-HB5-306	VL-1059	643-1059
11393-KN4-750	VL-1026	643-1026
11393-KT0-710	VL-1078	643-1078
11393-MG9-307	VL-1066	643-1066
11393-MG9-680	VL-1066	643-1066
11393-MV9-670	VL-1083	643-1083
11393-MY3-000	VL-1090	643-1090
11393-107-000	VL-1018	643-1018
11393-121-630	VL-1023	643-1023
11393-371-000	VL-1039	643-1039
11393-371-306	VL-1039	643-1039
11393-436-000	VL-1026	643-1026
11393-437-000	VL-1016	643-1016
11393-439-970	VL-1078	643-1078
11393-459-000	VL-1023	643-1023
11393-463-000	VL-1032	643-1032
11393-463-306	VL-1032	643-1032
11394-GW8-680	VL-1020	643-1020
11395-HA2-P00	VL-1030	643-1030
11394-HC4-840	VL-1072	643-1072
11394-HM3-670	VL-1087	643-1087
11394-HN1-A40	VL-1088	643-1088
11394-KA3-P00	VL-1043	643-1043
11394-KA3-740	VL-1043	643-1043
11395-KA4-770	VL-1046	643-1046
11394-KBV-000	VL-1049	643-1049
11394-KCY-670	VL-1088	643-1088
11394-KCZ-000	VL-1086	643-1086
11394-KE8-000	VL-1049	643-1049
11395-KS7-306	VL-1046	643-1046
11394-KZ1-920	VL-1047	643-1047
11394-KZ4-A90	VL-1074	643-1074
11394-KZ4-620	VL-1074	643-1074
11394-MA0-306	VL-1009	643-1009
11394-MB0-000	VL-1021	643-1021
11394-MB0-306	VL-1021	643-1021
11394-MB4-000	VL-1058	643-1058
11394-MB4-306	VL-1058	643-1058
11394-MC8-000	VL-1041	643-1041
11394-MC8-306	VL-1041	643-1041
11394-ML7-000	VL-1064	643-1064
11394-MM9-850	VL-1071	643-1071
11394-MN1-700	VL-1028	643-1028
11394-MR1-000	VL-1071	643-1071
11394-MR5-801	VL-1040	643-1040
11394-MV1-850	VL-1071	643-1071
11394-MY2-621	VL-1028	643-1028
11394-MY7-000	VL-1064	643-1064
11394-035-010	VL-1020	643-1020
11394-286-040	VL-1013	643-1013
11394-286-306	VL-1013	643-1013
11394-333-020	VL-1014	643-1014
11394-333-306	VL-1014	643-1014

## Sudco Part Number to OEM Cross Reference Clutch Cover Gaskets

### Honda

OEM Reference	Vesrah Ref	Order No.
11394-377-306	VL-1008	643-1008
11394-377-000	VL-1008	643-1008
11394-428-000	VL-1009	643-1009
11395-KA5-690	VL-1054	643-1054
11395-KZ3-880	VL-1085	643-1085
11395-MAC-680	VL-1054	643-1054
11395-MJ0-000	VL-1050	643-1050
11395-MM5-000	VL-1077	643-1077
11395-MW3-600	VL-1050	643-1050
11395-MW7-790	VL-1077	643-1077
11396-MN4-000	VL-1070	643-1070
11396-MY9-000	VL-1070	643-1070
11396-300-060	VL-1001	643-1001
11396-300-306	VL-1001	643-1001
11396-425-000	VL-1002	643-1002
11396-425-306	VL-1002	643-1002

### Kawasaki

11009-1033	VL-4025	643-4025
11009-1307	VL-4024	643-4024
11009-1320	VL-4012	643-4012
11009-1388	VL-4014	643-4014
11009-1484	VL-4039	643-4039
11009-1500	VL-4035	643-4035
11009-1540	VL-4034	643-4034
11009-1548	VL-4030	643-4030
11009-1556	VL-4051	643-4051
11009-1627	VL-4049	643-4049
11009-1671	VL-4042	643-4042
11009-1693	VL-4046	643-4046
11009-1698	VL-4049	643-4049
11009-1744	VL-4040	643-4040
11009-1836	VL-4039	643-4039
11009-1860	VL-4054	643-4054
11009-1954	VL-4049	643-4049
11009-1963	VL-4034	643-4034
11009-1967	VL-4046	643-4046
11009-1971	VL-4032	643-4032
11009-1976	VL-4020	643-4020
11009-1984	VL-4005	643-4005
11009-1996	VL-4037	643-4037
11060-1070	VL-4004	643-4004
11060-1099	VL-4051	643-4051
11060-1111	VL-4013	643-4013
11060-1185	VL-4056	643-4056
11060-1230	VL-4040	643-4040
11060-1148	VL-4035	643-4035
11060-1216	VL-4042	643-4042
11060-1350	VL-4055	643-4055
11060-1467	VL-4030	643-4030
11060-1494	VL-4057	643-4057
11060-1529	VL-4001	643-4001
11060-1532	VL-4025	643-4025
11060-1590	VL-4002	643-4002
11060-1648	VL-4042	643-4042
11060-1655	VL-4036	643-4036
11060-1715	VL-4043	643-4043
11061-0122	VL-4032	643-4032
11061-1126	VL-4004	643-4004
11061-1154	VL-4054	643-4054
14046-024	VL-4001	643-4001
14046-033	VL-4002	643-4002
14046-035	VL-4005	643-4005

# Clutch Cover Gaskets

## Sudco Part Number to OEM Cross Reference Clutch Cover Gaskets

### Suzuki

OEM Reference	Vesrah Ref	Order No.
11482-00B00-H17	VL-3045	<b>643-3045</b>
11482-00B20-H17	VL-3058	<b>643-3058</b>
11482-01B01-H17	VL-3044	<b>643-3044</b>
11482-01C10	VL-3060	<b>643-3060</b>
11482-02C10	VL-3033	<b>643-3033</b>
11482-12D02	VL-3068	<b>643-3068</b>
11482-13A00-H17	VL-3036	<b>643-3036</b>
11482-14D01	VL-3064	<b>643-3064</b>
11482-14D02	VL-3064	<b>643-3064</b>
11482-14D03	VL-3069	<b>643-3069</b>
11482-17E00	VL-3070	<b>643-3070</b>
11482-19B13	VL-3040	<b>643-3040</b>
11482-22A10	VL-3034	<b>643-3034</b>
11482-24501	VL-3035	<b>643-3035</b>
11482-27A20	VL-3039	<b>643-3039</b>
11482-27C02	VL-3055	<b>643-3055</b>
11482-28C01	VL-3059	<b>643-3059</b>
11482-28E10	VL-3075	<b>643-3075</b>
11482-31301-H17	VL-3016	<b>643-3016</b>
11482-38A10	VL-3065	<b>643-3065</b>
11482-38B10	VL-3066	<b>643-3066</b>
11482-38B20	VL-3066	<b>643-3066</b>
11482-40B10	VL-3056	<b>643-3056</b>
11482-41F00	VL-3065	<b>643-3065</b>
11482-43B00	VL-3067	<b>643-3067</b>
11482-43BV0	VL-3067	<b>643-3067</b>
11482-43D01	VL-3074	<b>643-3074</b>
11482-44110	VL-3006	<b>643-3006</b>
11482-45100-H17	VL-3001	<b>643-3001</b>
11482-45400-H17	VL-3007	<b>643-3007</b>
11482-45400	VL-3007	<b>643-3007</b>
11482-49000-H17	VL-3002	<b>643-3002</b>
11482-49100-H17	VL-3009	<b>643-3009</b>
11482-49201-H17	VL-3008	<b>643-3008</b>
11482-49202-H17	VL-3008	<b>643-3008</b>
K1100-91976	VL-4020	<b>643-4020</b>

## Sudco Part Number to OEM Cross Reference Clutch Cover Gaskets

### Yamaha

OEM Reference	Vesrah Ref	Order No.
1TX-15461-00-00	VL-2048	<b>643-2048</b>
1UY-15461-00-00	VL-2041	<b>643-2041</b>
1WG-15462-00-00	VL-2052	<b>643-2052</b>
2GH-15461-00-00	VL-2045	<b>643-2045</b>
2H7-15451-10-00	VL-2004	<b>643-2004</b>
2H7-15451-00-00	VL-2004	<b>643-2004</b>
2VM-15462-11-00	VL-2046	<b>643-2046</b>
2VM-15462-00-00	VL-2046	<b>643-2046</b>
256-15451-10-00	VL-2002	<b>643-2002</b>
256-15451-00-00	VL-2002	<b>643-2002</b>
3EG-15462-00-00	VL-2005	<b>643-2005</b>
3GD-15461-00-00	VL-2041	<b>643-2041</b>
3GG-15461-02-00	VL-2011	<b>643-2011</b>
3GG-15461-00-00	VL-2011	<b>643-2011</b>
3HE-15462-10-00	VL-2052	<b>643-2052</b>
3HT-15462-01-00	VL-2003	<b>643-2003</b>
3JM-15451-11-00	VL-2030	<b>643-2030</b>
3JM-15451-01-00	VL-2030	<b>643-2030</b>
3KM-15461-00-00	VL-2006	<b>643-2006</b>
3KS-15461-00-00	VL-2045	<b>643-2045</b>
3L5-15451-11-00	VL-2015	<b>643-2015</b>
3L5-15451-10-00	VL-2015	<b>643-2015</b>
3L5-15451-01-00	VL-2015	<b>643-2015</b>
3MT-15451-00-00	VL-2024	<b>643-2024</b>
3R4-15462-11-00	VL-2016	<b>643-2016</b>
3R4-15462-00-00	VL-2016	<b>643-2016</b>
30X-15461-00-00	VL-2037	<b>643-2037</b>
34K-15462-00-00	VL-2013	<b>643-2013</b>
353-15451-00-00	VL-2024	<b>643-2024</b>
4AW-15451-00-00	VL-2028	<b>643-2028</b>
4BD-15462-00-00	VL-2017	<b>643-2017</b>
4BE-15462-00-00	VL-2012	<b>643-2012</b>
4BH-15461-00-00	VL-2045	<b>643-2045</b>
4DW-15462-00-00	VL-2013	<b>643-2013</b>
4EL-15461-04-00	VL-2037	<b>643-2037</b>
4ES-15461-00-00	VL-2059	<b>643-2059</b>
4FM-15461-00-00	VL-2045	<b>643-2045</b>
4G0-15461-01-00	VL-2006	<b>643-2006</b>
4G0-15461-00-00	VL-2006	<b>643-2006</b>
4H7-15461-00-00	VL-2022	<b>643-2022</b>
4JY-15462-00-00	VL-2064	<b>643-2064</b>
4L0-15461-00-00	VL-2011	<b>643-2011</b>
4X7-15462-00-00	VL-2005	<b>643-2005</b>
5H0-15462-00-00	VL-2017	<b>643-2017</b>
5WM-15461-02-00	VL2048	<b>643-2048</b>
5X2-15462-10-00	VL-2018	<b>642-2018</b>
5X2-15462-00-00	VL-2018	<b>642-2018</b>
5Y1-15462-01-00	VL-2013	<b>643-2013</b>
15A-15462-00-00	VL-2012	<b>643-2012</b>
517-15451-00-00	VL-2028	<b>643-2028</b>



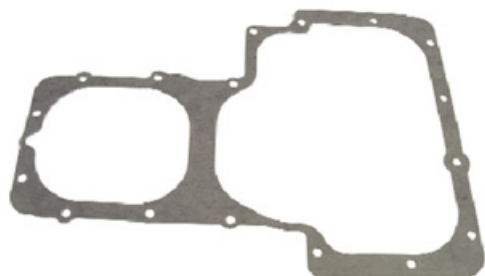

## Vesrah Oil Pan Gasket

Sold each. *Made in Japan.*

### Kawasaki

OEM Ref. 11060-1074	Order No. 646-4001
Z1/Z1A/Z1B-900	73-75
KZ900A4/A5	76-77
KZ900B1 LTD	1976
KZ1000A1/A2	77-78
KZ1000A3/A3A/A4 MKII	79-80
KZ1000B1/B2/B3/B4 LTD	77-80
KZ1000C1/C1A/C2/C3/C4	78-81
KZ1000D1 Z1R	1978
KZ1000D3 Z1R	1980
KZ1000E1/E2 Shaft ST	79-80
KZ1000G1 Classic LTD	1980
KZ1000J1/J2/J3	81-83
KZ1000K1/K2 LTD	81-82
KZ1000M1/M2 CSR	81-82
KZ1000P1-P21 Police	82-02
KZ1000P24 Police	2005
KZ1000R1/R2 Replica	82-83
KZ1100A1/A2/A3 Shaft	81-83
KZ1100B1/B2 GPz	81-82
KZ1100D1/D2 Spectre	82-83
KZ1100L1 LTD	1983
ZN1100B1/B2 LTD	84-85
ZX1100A1/A2 GPz	83-84



005-198



005-199

## K&N Rubber Base Crankcase Vent Filters

Filters are designed to clamp directly to metal or plastic tubing. Ideal for engines, transmissions, oil and gas tanks on racing vehicles. Sold each.

Rubber Top				
Flange I.D.	Filter Diameter	Filter Height	K&N No.	Order No.
1-1/4"	3"	2-1/2"	62-1380	005-198
Chrome Top				
1-1/4"	3"	2-1/2"	62-1390	005-199



005-195



005-196



005-197

## K&N Steel Base Crankcase Vent Filters

One piece design for competition use. 2" O.D. x 1-1/2" long (height) with rubber top. All base plates are chrome plated. Sold each.

Vent Tube Diameter	K&N No.	Order No.
1/2"	62-1010	005-195
5/8"	62-1020	005-196
3/4"	62-1030	005-197



## Oil Level Gauge

Oil sight gauge for Kawasaki Z1/ KZ1000 models. Sold each. *Made in Japan.*

Order No. 950-265

See applications on right.

### Kawasaki

OEM Reference 52015-004	Order No. 950-265
KZ650B1/B2/B2A/B3	77-79
KZ650D1/D1A/D2 SR	78-79
KZ750B1/B2/B3/B4 2-cylinder	75-79
KZ750G1 LTD 2-cylinder	1980
Z1/A/B-900	73-75
KZ900A4/A5	76-77
KZ900B1 LTD	1976
KZ1000A1/A2	77-78
KZ1000A3/A3A/A4 MKII	79-80
KZ1000B1/B2/B3/B4 LTD	77-80
KZ1000C1/C1A-C4 Police	78-81
KZ1000D1 Z1R	1978
KZ1000D3 Z1R	1980
KZ1000E1/E2 Shaft ST	79-80
KZ1000G1 LTD Classic	1980
KZ1300A1/A2 up to engine no. 009426	79-80

# Hamaguchi Exhaust Systems



## Hamaguchi Full & Slip-on Race Systems

Hamaguchi Ti full exhaust systems truly are works of art. You won't find better craftsmanship at any price anywhere. These are the same exhaust systems used by the four time FIM Asia Supersport Champion. Each pipe is hand made by skilled craftsman who use the "Wagiri" method of forming tight radius bends without disrupting flow. This method of pipe fabrication is used on GP and high end race machines. Also, variable diameter tubing is used throughout the length of piping to ensure best power is made.

Because of the many hours of research put into developing the FIM Asia championship winning machine, the power output of these systems is quite good. These fully titanium systems are very light weight with excellent flow and sound.

### Kawasaki

Model	Year	Full System	Slip-On
ZX600 Ninja ZX-6R	05-06	<a href="#">502-6000</a>	_____
ZX1000 Ninja ZX-10R	04-05	<a href="#">502-6010</a>	_____
ZX1400 Ninja ZX-14	06-07	_____	<a href="#">502-6100</a>

### Suzuki

GSX-R600	2006	_____	<a href="#">502-4100</a>
GSX-R750	2006	_____	<a href="#">502-4100</a>
GSX-R1000	05-06	_____	_____
GSX-R1000	07-08	_____	<a href="#">502-4110</a>
GSX1300R Hayabusa	99-07	_____	<a href="#">502-4105</a>

### Yamaha

YZF-R6	2006	<a href="#">502-2000</a>	<a href="#">502-2100</a>
YZF-R6 Moto-GP Slip-On	06-07	_____	<a href="#">502-2105</a>



**Kawasaki ZX600 "ZX-6R"**



Order No. [502-4110](#)



Order No. [502-2105](#)

## Universal Muffer Packing Kit

Heavy duty, high density muffer packing with extreme heat capability. Measures 1" x 11" x 16". Sold each.

Order No. [502-9200](#)

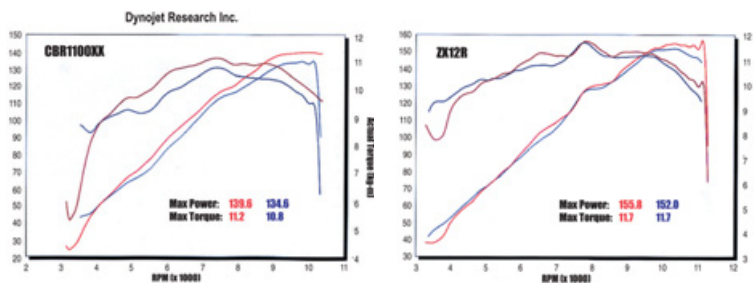

■ Sudco Pipe  
■ Stock Pipe

## Sudco Exhaust Systems

Sudco full exhaust systems are made exclusively in Japan for Sudco International. Sudco exhaust systems feature high quality stainless steel tubing that are polished to a mirror like finish. With light weight and great looks in mind; exhaust fumes exit an even weave carbon fiber exhaust canister. The Sudco exhaust systems perform just as amazing as they look with mandrel bend tubing and 4-2-1 collectors, producing strong mid-range power increases that carries all the way to redline. Available for the following models:

## Kawasaki

Model	Year	Order No.
ZX12R	Ninja	00-03

## Suzuki

GSX-R600	01-04	502-S436
GSX-R750	00-03	502-S436
GSX-R1000	01-03	502-S438



## Helix Exhaust Springs with Straight Hook

Zinc plated with straight hook end exhaust springs. Sold in pairs.

Description	Order No.	Description	Order No.
57mm	502-9250	80mm	502-9250
63mm	502-9251	83mm	502-9251
67mm	502-9252	90mm	502-9252
70mm	502-9253	95mm	502-9253
75mm	502-9254		



## Helix Exhaust Springs with Swivel Hook

Stainless steel with swivel hook-end exhaust springs. Sold in pairs.

Description	Order No.	Description	Order No.
38mm	502-9270	75mm	502-9276
57mm	502-9271	80mm	502-9277
60mm	502-9272	83mm	502-9278
63mm	502-9273	90mm	502-9279
67mm	502-9274	95mm	502-9280
70mm	502-9275	100mm	502-9281

## Motion Pro Spring Hooks (Pullers)

Use to remove exhaust pipe springs, seat or tank holding springs, cotter pins, side stand springs and other parts. Sold each.

Description	Order No.
Standard Spring Hook	950-725
Heavy Duty T-Handle Spring Hook	950-726



# Hardware, Heat Shield & Exhaust Wrap



502-9225



502-9227



## Heat Shield

Fiberglass cloth, 1/32" thick, with aluminum foil. Attaches easily with adhesive. Protects against heat on side covers or near electrical connectors. Sold each.

Description	Order No.
1.5" width by 3" length with adhesive	502-9225
1.5" width by 15" length roll with adhesive	502-9226
18" width by 18" length sheet with adhesive	502-9227

## Exhaust Wrap

Black or tan fiberglass cloth header wrap. Use on exhaust systems to reduce heat and for protection. Sold each.

Description	Order No.
Black 1" width by 50' length roll	502-9211
Black 2" width by 50' length roll	502-0211
Tan 1" width by 50' length roll	502-9215
Tan 1" width by 50' length roll	502-9216



## Off-Road Hardware Kit 170pcs

170 piece kit contains a selection of metric nuts, bolts & washers most commonly needed for off-road and street bike repair. Covers body panel retainers to kick starter bolts. Compact and durable snap lock plastic box with dividers that can be easily stowed in your car, truck, trailer or toolbox. Box measures 11 in x 8 in x 2 in. Includes 10 of each of following

Order No. 950-781

Description	Description	Description
8 mm Flange Nuts	8 mm Nylock Nuts	6 mm Nylock Nuts
6 mm Hex Nuts	8 mm Hex Nuts	8 mm Fuji Nuts
6 mm Flat Washers	8 mm Flat Washers	6 X 16 Pan Head
10 mm Flat Washers	6 mm Fender Washers	6 X 30 Pan Head
6 X 25 Allen Bolts	6 X 16 Flange Bolt	8 X 30 Flange Bolt
8 X 30 Allen Bolts	8 X 16 Flange Bolt	



## Metric Flange Head Bolts Hardware Kit (Zinc)

Contains 10 pcs of each of the following zinc plated bolts and durable compact snap lock plastic box with dividers.

Order No. 950-783

Description	Description	Description
6 X 10 Flange Bolt	6 X 35 Flange Bolt	8 X 25 Flange Bolt
6 X 16 Flange Bolt	6 X 40 Flange Bolt	8 X 30 Flange Bolt
6 X 20 Flange Bolt	6 X 45 Flange Bolt	8 X 35 Flange Bolt
6 X 25 Flange Bolt	8 X 16 Flange Bolt	8 X 40 Flange Bolt
6 X 30 Flange Bolt	8 X 20 Flange Bolt	8 X 50 Flange Bolt





## Metric Nut Hardware Kit (Zinc)

Contains 10 pcs of each of the following zinc plated nuts and durable compact snap lock plastic box with dividers.

Order No. 950-781

Description	Description	Description
5mm Nut	8mm Nylock Nut	6mm Fuji Lock Nut
6mm Nut	10mm Nylock Nut	8mm Fuji Lock Nut
8mm Nut	5mm Flange Nut	10mm Fuji Lock Nut
10mm Nut	6mm Flange Nut	12mm Fuji Lock Nut
12mm Nut	8mm Flange Nut	5mm Acorn Low Dome
4mm Nylock Nut	10mm Flange Nut	6mm Acorn Low Dome
5mm Nylock Nut	12mm Flange Nut	8mm Acorn Low Dome
6mm Nylock Nut	12mm Flange Nut	10mm Acorn Low Dome
		12mm Acorn Low Dome

## Metric Allen Bolt Hardware Kit (Zinc)

Contains 10 pcs of each of the following zinc plated bolts and durable compact snap lock plastic box with dividers.

Order No. 950-784

Description	Description	Description
6 X 10 Allen	6 X 45 Allen	8 X 25 Allen
6 X 12 Allen	6 X 50 Allen	8 X 30 Allen
6 X 18 Allen	6 X 55 Allen	8 X 35 Allen
6 X 25 Allen	6 X 60 Allen	8 X 40 Allen
6 X 30 Allen	6 X 65 Allen	8 X 45 Allen
6 X 35 Allen	6 X 70 Allen	
6 X 40 Allen	8 X 20 Allen	



## Metric Washer Hardware Kit (Zinc)

Contains 10 pcs of each of the following zinc plated washers and durable compact snap lock plastic box with dividers.

Order No. 950-780

Description	Description	Description
4mm Flat Washer	12mm Flat Washer	10mm Lock Washer
5mm Flat Washer	4mm Lock Washers	12mm Lock Washer
6mm Flat Washer	5mm Lock Washer	6mm Fender Washer
8mm Flat Washer	6mm Lock Washer	8mm Fender Washer
10mm Flat Washer	8mm Lock Washer	

## Metric Hex Bolt Hardware Kit (Zinc)

Contains 10 pcs of each of the following zinc plated metric grade 4.8 bolts and durable compact snap lock plastic box with dividers.

Order No. 950-782

Description	Description	Description
6 X 10 Bolt	6 X 50 Bolt	10 X 20 Bolt
6 X 15 Bolt	8 X 10 Bolt	10 X 25 Bolt
6 X 20 Bolt	8 X 25 Bolt	10 X 30 Bolt
6 X 25 Bolt	8 X 30 Bolt	10 X 35 Bolt
6 X 30 Bolt	8 X 35 Bolt	10 X 40 Bolt
6 X 35 Bolt	8 X 40 Bolt	10 X 45 Bolt
6 X 40 Bolt	8 X 45 Bolt	10 X 50 Bolt
6 X 45 Bolt	8 X 50 Bolt	

## Exhaust Pipe Plug

For use on 2-stroke and 4-stroke mufflers. Prevents water from entering exhaust muffler and keeps muffler packing fresh. Sold each.

Order No. 502-9205





## Sudco 7.5mm Valve Adjustment Shim Kits

Sudco shims are OEM specific dimensions for proper fitment. (7.47mm - 7.49mm) Available in shop kit and individual sizes. Individual sizes sold each. **Made in Japan.**

See model application list on next column.

### Honda/Kawasaki/Suzuki/Yamaha 7.50mm Diameter

7.5mm Diameter Dealer Shim Kit 1.35mm - 2.15mm (total 34 shims)

**Order No. 035-001**

Includes storage box and qt 2 each size of the following:

1.35, 1.40, 1.45, 1.50, 1.55, 1.60, 1.65, 1.70, 1.75, 1.80, 1.85  
1.90, 1.95, 2.00, 2.05, 2.10, 2.15

7.5mm Diameter Dealer Shim Kit 2.20mm - 3.00mm (total 34 shims)

**Order No. 035-002**

Includes storage box and qt 2 each size of the following:

2.20, 2.25, 2.30, 2.35, 2.40, 2.45, 2.50, 2.55, 2.60, 2.65, 2.70  
2.75, 2.80, 2.85, 2.90, 2.95 3.00

## 7.50mm Valve Adjustment Shims

Sizes available from 1.35 mm thickness - 3.00mm thickness. Sold each.

Size	Order No.	Size	Order No.
1.35 mm	035-100	2.20 mm	035-117
1.40 mm	035-101	2.25 mm	035-118
1.45 mm	035-102	2.30 mm	035-119
1.50 mm	035-103	2.35 mm	035-120
1.55 mm	035-104	2.40 mm	035-121
1.60 mm	035-105	2.45 mm	035-122
1.65 mm	035-106	2.50 mm	035-123
1.70 mm	035-107	2.55 mm	035-124
1.75 mm	035-108	2.60 mm	035-125
1.80 mm	035-109	2.65 mm	035-126
1.85 mm	035-110	2.70 mm	035-127
1.90 mm	035-111	2.75 mm	035-128
1.95 mm	035-112	2.80 mm	035-129
2.00 mm	035-113	2.85 mm	035-130
2.05 mm	035-114	2.90 mm	035-131
2.10 mm	035-115	2.95 mm	035-132
2.15 mm	035-116	3.00 mm	035-133

## Honda

Model	Year
NX250	88-90
CB400 CB1 400	89-90
CB600F (599)	04-05
CBR600F2 Hurricane	91-94
CBR600F3 Hurricane	95-98
CBR600F4 Hurricane	99-05
CBR600F4i Hurricane	99-05
CBR600RR	03-05
CBR600SE Hurricane	1998
CBR600SJR Replica	1996
FSC600 Silverwing	02-05
FSC600A (ABS)	03-05
FSC600D Silverwing	2003
RVF750R RC45	1994
VF750C Magna	94-03
VF750CD Magna Deluxe	95-96
VF750C2 Magna Deluxe	97-00
VFR750F	90-97
VFR750R RC30	1990
VFR800FI Interceptor	98-01
VFR800 Interceptor	02-05
VFR800A Interceptor ABS	02-05

## Honda Street

Model	Year
CB900F 919	02-05
CBR900RR/CBR929/CBR954	93-03
CBR1000RR	04-05
CBR1100XX Blackbird	97-03
ST1100/A	91-02
ST1300/A	03-05
GL1800/A Goldwing	01-05
NRX1800DA/DB/EA/EB Valkyrie Rune	04-05

## Honda Offroad

CRF250R/CRF250X	04-05
-----------------	-------

## Kawasaki Street

ZX600D1/D2/D3/D4 Ninja ZX-6	90-93
ZX600E1-E10 Ninja ZX-6	93-02
ZX600E11/E12 ZZR600	03-04
ZX600F1/F2/F3 Ninja ZX-6R	95-97
ZX600G1/G2 Ninja ZX-6R	98-99
EJ650A2/A3/A4 W650	00-02
ZX750J1/J2 Ninja ZX-7	91-92
ZX750K1/K2 Ninja ZX7-R	91-92
ZX750L1/L2/L3 Ninja ZX-7	93-95
ZX750M1/M2 Ninja ZX7-R	93-94
ZX750N1/N2 Ninja ZX7-RR	96-97
ZX750P1-P8 Ninja ZX7-R	96-03
ZX900B1/B2/B3/B4 Ninja ZX-9R	94-97
ZX900C/E/F Ninja ZX-9R	98-03
ZR1000A1/A2/A3 Z1000	03-05
ZX1000C1/C2 Ninja ZX-10R	04-05

## Kawasaki Dual Sport & Offroad

KL250G4/G5/G6/G7 Super Sherpa	00-03
KLX250D2/D3/D4	94-96
KLX300A2-A10	97-05

## Suzuki Street

GSX-R600WN/WP	92-93
GSX-R600V/WX/Y/K1/K2/K3/K4/K5	97-05
GSX-R600ZK3	2003
RF600RR/RS/RT	94-96
AN650K3/K4/K5 Burgman	03-05
SV650X/Y/K1/K2/K3/K4/K5	99-05
SV650SX/SY/SK1/SK2/SK3/SK4/SK5	99-05
GSX-R750WP/WVR/WS	93-95
GSX-R750T/V/WI/X/Y/K1/K2/K3/K4/K5	96-05
RF900RR/RS/RZS/RT/RV	94-97
GSX-R1000K1/K2/K3/K4/K5	01-05
GSX-R1100WP/WR/WS/WT/WV/WW	93-98

## Suzuki Offroad

DR-Z250K1/K2/K3/K4/K5	01-05
-----------------------	-------

## Yamaha Street

FZR400U/SUC/W/SWC/A/SAC	88-90
FZ600SS/ST/STC FZ6	04-05
FZR600W/WC/AC/RA/RAC-RL/RLC	89-99
YZF600RG/RG-RV/RVC	95-06
YZF-R6L/LC/-T/TC	99-05
YZF-R6SN/SNC Champions Limited Ed.	2001
YZF750RF/RFC-RK/RKC	94-98
FZR1000W/WC-G/GC	89-95
FZS1000N/NC/-T/TC FZ-1	01-05
GTS1000AE/AEC/AF/AFC	93-94
YZF1000R/J/RJ/RK/RKC	97-98
YZF-R1L/LC-T/TC	99-05
YZF-R1SN/SNC Champions Limited Ed.	2001



## Sudco 9.50mm Valve Adjustment Shim Kit

Sudco shims are OEM specific dimensions for proper fitment. Available in shop kit and individual sizes.

Individual sizes sold each. **Made in Japan.**

### Honda/Kawasaki/Suzuki/Yamaha 9.50mm Diameter

9.5mm Diameter Dealer Shim Kit 2.35mm - 3.30mm (total 34 shims)

**Order No. 035-006**

Includes storage box and qt 2 each size of the following:

2.30, 2.35, 2.40, 2.45, 2.50, 2.55, 2.60, 2.65, 2.70, 2.75, 2.80, 2.85  
2.90, 2.95, 3.00, 3.05, 3.10, 3.15, 3.20, 3.25, 3.30.

### Valve Shim Storage Box

**Order No. 008-001**

## 9.50mm Valve Adjustment Shims

Sizes available from 2.30 mm thickness - 3.30mm thickness.

Sold each.

Size	Order No.	Size	Order No.
2.30mm	<b>035-243</b>	2.85mm	<b>035-230</b>
2.35 mm	<b>035-220</b>	2.90mm	<b>035-231</b>
2.40 mm	<b>035-221</b>	2.95mm	<b>035-232</b>
2.45mm	<b>035-222</b>	3.00mm	<b>035-233</b>
2.50mm	<b>035-223</b>	3.05mm	<b>035-234</b>
2.55mm	<b>035-224</b>	3.10mm	<b>035-235</b>
2.60mm	<b>035-225</b>	3.15mm	<b>035-236</b>
2.65mm	<b>035-226</b>	3.20mm	<b>035-237</b>
2.70mm	<b>035-227</b>	3.25mm	<b>035-238</b>
2.75mm	<b>035-228</b>	3.30mm	<b>035-239</b>
2.80mm	<b>035-229</b>		

## Honda Street

Model	Year
RVT1000R RC51	00-05
VTR1000F Superhawk	98-05

## Honda ATV

TRX450R ATV	04-05
-------------	-------

## Honda Offroad

CRF450R	02-05
CRF450X	04-05



## Kawasaki Street

Model	Year
ZX750H1/H2 Ninja ZX-7	89-90
VN800A1-A11 Vulcan 800	95-05
VN800B1-B10 Vulcan 800 Classic	96-05
VN800C1/C2 Vulcan 800 Drifter	99-00
VN800E1/E2/E3/E4/E5 Vulcan 800 Drifter	01-05
ZX1000B1/B2/B3 Ninja ZX-10	88-90
ZR1100C3/C4 ZRX1100	99-00
ZX1100C1/C2/C3 Ninja ZX-11	90-92
ZX1100D1-D9 Ninja ZX-11	93-01
ZX1100E1/E2/E3 GPz	95-97
ZX1100F1 GPz (ABS)	1996
ZX1200A1/A2 Ninja ZX-12R	00-01
ZX1200B1/B2/B3/B4 Ninja ZX-12R	02-05
ZX1200C1/C2/C3/C4 ZZR1200	02-05
ZR1200A1/A2/A3/A4/A5 ZRX1200	01-05

## Kawasaki ATV

KSF400A1/A2/A3 KFX400	03-05
-----------------------	-------

## Kawasaki Dual Sport & Offroad

KLX400A1 KLX400SR Dual Sport	2003
KLX400B1 KLX400R Offroad	2003

## Kawasaki Personal Watercraft

JT1200B1/B2 Jet Ski STX12F	03-04
JT1500A1 Jet Ski STX15F	2004

## Suzuki Street

GSX600FN/FP/FR/FS/FT/FV Katana	92-97
GSX-R750M/N	91-92
DL1000K2/K3/K4/K5 V-Storm	02-05
SV1000K3/K4/K5	03-05
SV1000SK3/SK4/SK5	03-05
TL1000SV/SW/SX/SY/SK1	97-01
TL1000RW/RX/RY/RK1/RK2/RK3/RK4	98-04
GSX-R1100M/N	91-92
GSX1300RX/RY/RK1/RK2/RK3 Hayabusa	99-03
GSX1300RK4/RK5 Hayabusa	04-05

## Suzuki ATV

LT-Z400K3/K4/K5 Z400 QuadSport	03-05
--------------------------------	-------

## Suzuki Dual Sport & Offroad

DR-Z400Y/K1/K2/K3 Offroad	00-03
DR-Z400SY/SK1/SK2/SK3/SK4 Dual Sport	00-04
DR-Z400EY/EK1/EK2/EK3/EK4 Offroad	00-04

## Yamaha Street

TDM850D/DC/E/EC	92-93
FJR1300AS/ASC/AT/ATC ABS	04-05
FJR1300R/RC/S/SC/T/TC	03-05

## Yamaha ATV

YFZ450S/T	04-05
YFZ450SET Special Edition	2005

## Yamaha Offroad

TT250RL/RLC	1999
TT-R250M/MC/N/NC/P/PC/R/RC	00-03
TT-R250S/SC/T/TC/V/V/C Offroad	04-06
WR400FK/FL/FM Offroad	98-00
YZ400FK/FL Offroad	98-99
YZ426FM/FN/FP Offroad	00-02
WR426FN/FP Offroad	01-02
WR450FR/FS/FT Offroad	03-05
YZ450FR/FS/FT Offroad	03-05

# Valve Shims



## 13mm Valve Adjustment Shim Kits

Sold as dealer kit and in individual sizes. Individual sizes sold each. See model application list on next column.

### Kawasaki 13mm Diameter

13mm Diameter Dealer Shim Kit 2.30mm - 3.10mm

#### Order No. 035-025

Includes storage box and qt 2 each size of the following:  
2.30, 2.40, 2.50, 2.55, 2.60, 2.65, 2.70, 2.75, 2.80, 2.85, 2.90, 2.95, 3.00, 3.10

Valve Shim Storage Box **Order No. 008-001**

## 13mm Valve Adjustment Shims

Sizes available from 2.30mm - 3.10mm thickness. Sold each.

Size	Order No.	Size	Order No.
2.30mm	<b>035-619</b>	2.75mm	<b>035-628</b>
2.40mm	<b>035-621</b>	2.80mm	<b>035-629</b>
2.50mm	<b>035-623</b>	2.85mm	<b>035-630</b>
2.55mm	<b>035-624</b>	2.90mm	<b>035-631</b>
2.60mm	<b>035-625</b>	2.95mm	<b>035-632</b>
2.65mm	<b>035-626</b>	3.00mm	<b>035-633</b>
2.70mm	<b>035-627</b>	3.10mm	<b>035-635</b>

## Kawasaki Street

Model	Year
KZ550A1/A2/A3	80-82
KZ550A4	1983
KZ550C1-C4 LTD	80-83
KZ550D1 GPz	1981
KZ550F1/F2 Spectre & LTD	83-84
KZ550H1/J2 GPz	82-83
KZ550M LTD	1983
ZR550B1/B2/B3/B4 Zephyr	90-93
ZX550A1/A2/A3 GPz	84-86
KZ650B1/B2/B2A	77-78
KZ650B3	1979
KZ650C1/C2 Custom	77-78
KZ650C3 Custom	1979
KZ650D1/D1A SR	1978
KZ650D2 SR	1979
KZ650E1 LTD	1980
KZ650F1	1980
KZ650H1/H2 CSR	81-82
KZ650H3	1983
KZ700A1	1984
ZN700A1/A2 LTD	84-85
KZ750E1/E2/E3	80-82
KZ750F1 LTD	1983
KZ750H1/H2/H3 LTD	80-82
KZ750H4	1983
KZ750L3	1983
KZ750N1/N2 Spectre	82-83
KZ750R1 GPz	1982
ZR750C1/C2/C3 Zephyr	91-93
ZR750F2 ZR-7	2000
ZR750H1/H2/H3 ZR-7S	01-03
ZX750A1/A2/A3 GPz	83-85
ZX750E1/E2 GPz Turbo	84-85
ZR1100A1/A2/A3/A4	92-95
ZR1100C/3C4 ZRX1100	99-00
ZX1100A1/A2 GPz	83-84





## 25mm Valve Adjustment Shim Kits

Sold as dealer kit and in individual sizes. Individual sizes sold each. See model application list on next column.

### Honda/Triumph/Yamaha 25mm Diameter

25mm Diameter Dealer Shim Kit 2.30mm - 2.70mm (total 34 shims)

**Order No. 035-010**

Includes storage box and qt 2 each size of the following:

2.30, 2.35, 2.40, 2.45, 2.50, 2.55, 2.60, 2.65, 2.70

25mm Diameter Dealer Shim Kit 2.75mm - 3.10mm

**Order No. 035-011**

**Valve Shim Storage Box**

**Order No. 008-001**

## 25mm Valve Adjustment Shims

Sizes available from 2.30mm - 3.20mm thickness. Sold each.

Size	Order No.	Size	Order No.
2.30mm	<b>035-319</b>	2.75mm	<b>035-328</b>
2.35mm	<b>035-320</b>	2.80mm	<b>035-329</b>
2.40mm	<b>035-321</b>	2.85mm	<b>035-330</b>
2.45mm	<b>035-322</b>	2.90mm	<b>035-331</b>
2.50mm	<b>035-323</b>	2.95mm	<b>035-332</b>
2.55mm	<b>035-324</b>	3.00mm	<b>035-333</b>
2.60mm	<b>035-325</b>	3.05mm	<b>035-334</b>
2.65mm	<b>035-326</b>	3.10mm	<b>035-335</b>
2.70mm	<b>035-327</b>	3.20mm	<b>035-337</b>



## Motion Pro Valve Shim Tools

Manufactured from hardened alloy steel. Compresses valve shim bucket for removal of valve adjustment shim.

**Valve Shim Tool for Honda DOHC** **Order No. 950-436**

CB750C/F/K/L/SC 80-83, CB900C/F 80-82

CB1000C 1983, CB1100F 1983, CBX1047cc 79-82

Use on Honda applications listed on next column

**Valve Shim Tool for Yamaha XJ600 only** **Order No. 950-435**

XJ600 Seca II (92-98) Use with XJ600 application only

## Honda Street

Model	Year
CB750C Custom	80-82
CB750F Super Sport	79-82
CB750K	79-82
CB750L LTD	1979
CB750SC Nighthawk	82-83
CB900C Custom	80-82
CB900F Super Sport	81-82
CB1000C Custom	1983
CB1100F Super Sport	1983
CBX1047cc	79-82

## Triumph

All watercooled three & four cylinder models

## Yamaha Street

SRX250T/TC	1987
XJ600SD/SDC-SK/SKC Seca II	92-98
XVZ12TK/TDK Venture & Venture Royale	1983
XVZ12DL/DKC2/DN Venture Royale	84-85
XVZ13DS/DT Venture Royale	86-87
XVZ13DSC/DTC Venture Royale	86-87
XVZ13T/TC/U/UC Venture	87-88
XVZ13DU/DUC/DW/DWC Venture Royale	88-89
XVZ13DA/DAC/DB/DBC Venture Royale	90-91
XVZ13DD/DDC/DE/DEC Venture Royale	92-93
VMX12N/NC/S/SC V-Max	85-86
VMX12UUC/WWC/AAC/BBC/DDC/EE/EC V-Max	88-93
VMX12F/FC/G/GC/H/HC/J/JC/K/KC/L/LC V-Max	94-99
VMX12M/MC/N/NC/P/PC/R/RC V-Max	00-03
VMX12S1/S1C/T/TC/V/VC/W1/W1C V-Max	04-07
FJ1100L/LC/N/NC	84-85
FJ1200S/SC/T/TC	86-87
FJ1200W/WC/A/AC/B/BC/D/DC	89-92
FJ1200AD/ADC/AE/AEC (ABS)	92-93
XVZ1300AH/AHC/AJ/AJC/AK/AKC Royal Star	96-98
XVZ1300AL/ALC/AM/AMC Royal Star Boulevard	99-00
XVZ1300AN/ANC Royal Star Boulevard	2001
XVZ1300ATH/ATHC/ATJ/ATJC Royal Star Tour Classic	96-97
XVZ1300ATK/ATKC/ATL/ATLC Royal Star Tour Classic	98-99
XVZ1300ATM/ATMC Royal Star Tour Classic	2000
XVZ1300LTJ/LTJCLTK/LTKC Royal Star Tour Deluxe	97-98
XVZ1300TL/LTLCLTML/TMC Royal Star Tour Deluxe	99-00
XVZ1300LTN/LTNC Royal Star Tour Deluxe	2001
XVZ1300CTT/CTC Royal Star Tour Deluxe	2005
XVZ1300TFSMC Royal Star Venture MM	2000
XVZ1300TFL/TFLC/TFW/TFMC Royal Star Venture	99-00
XVZ1300TFN/TFNC/TFP/TFPC Royal Star Venture	01-02
XVZ1300TFR/TFRC/TFS/TFSC Royal Star Venture	03-04
XVZ1300TFT/TFTC Royal Star Venture	2005
XVZ1300TFSP/TFSPC Royal Star Midnight Venture	2002
XVZ1300TFSR/TFSRC Royal Star Midnight Venture	2003
XVZ1300TFMS/TFMSC Royal Star Midnight Venture	2004
XVZ1300TFMT/TFMTC Royal Star Midnight Venture	2005

## Yamaha Dual Sport & Offroad

XT250L/LC Dual Sport	1984
TT350S/T Offroad	86-87
XT350N/NC-M/MC Dual Sport	85-00



## 29mm Valve Adjustment Shim Kits

Sold as dealer kit and in individual sizes. Individual sizes sold each. See model application list on next column.

### Kawasaki/Yamaha 29mm Diameter

Dealer Shim Kit 2.00mm - 2.50mm

**Order No. 035-015**

Includes storage box and qt 2 each size of the following:

2.00, 2.05, 2.10, 2.15, 2.20, 2.25, 2.30, 2.35, 2.40, 2.45, 2.5

Dealer Shim Kit 2.55mm - 3.10mm

**Order No. 035-016**

Includes storage box and qt 2 each size of the following:

2.55, 2.60, 2.65, 2.70, 2.75, 2.80, 2.85, 2.90, 2.95, 3.00, 3.05, 3.10

Valve Shim Storage Box

**Order No. 008-001**

## 29mm Valve Adjustment Shims

Sold each. Sizes available from 2.00mm - 3.10mm thickness.

Size	Order No.	Size	Order No.
2.00 mm	<a href="#">035-413</a>	2.55mm	<a href="#">035-424</a>
2.05mm	<a href="#">035-414</a>	2.60mm	<a href="#">035-425</a>
2.10mm	<a href="#">035-415</a>	2.65mm	<a href="#">035-426</a>
2.15mm	<a href="#">035-416</a>	2.70mm	<a href="#">035-427</a>
2.20mm	<a href="#">035-417</a>	2.75mm	<a href="#">035-428</a>
2.25mm	<a href="#">035-418</a>	2.80mm	<a href="#">035-429</a>
2.30mm	<a href="#">035-419</a>	2.85mm	<a href="#">035-430</a>
2.35mm	<a href="#">035-420</a>	2.90mm	<a href="#">035-431</a>
2.40mm	<a href="#">035-421</a>	2.95mm	<a href="#">035-432</a>
2.45mm	<a href="#">035-422</a>	3.00mm	<a href="#">035-433</a>
2.50mm	<a href="#">035-423</a>	3.05mm	<a href="#">035-434</a>
		3.10mm	<a href="#">035-435</a>



## Cam Cover End Plugs **NEW**

Billet aluminum machined cam cover plugs with satin finish. Will not blow out or suck as the stock rubber plugs. Fits Kawasaki Z1/KZ900 and KZ1000 models shown. Sold in set of 4.

**Order No: 620-9990**

## Motion Pro Valve Shim Tools

Manufactured from hardened alloy steel. Compresses valve shim bucket for removal of valve adjustment shim.

Valve Shim Tool for Kawasaki

**Order No. 950-437**

Z1/A/B-900/KZ900/KZ1000/KZ1100/KZ1300/ZN1300

Use on Kawasaki applications listed on next column

Valve Shim Tool for Yamaha

**Order No. 950-438**

XJ550/XJ650/XJ750/XS750/XS850/XS1100

Use on all Yamaha applications listed on next column

## Kawasaki Street

Model	Year
Z1/A/B-900	73-75
KZ900A4/A5	76-77
KZ900B1 LTD	1976
KZ1000A1/A2	77-78
KZ1000A3/A3A/A4 MKII	79-80
KZ1000B1/B2/B3/B4 LTD	77-80
KZ1000C1/C1A/C2/C3/C4 Police	78-81
KZ1000D1 Z1R	1978
KZ1000D3 Z1R	1980
KZ1000E1/E2 Shaft ST	79-80
KZ1000G1 LTD Classic	1980
KZ1000J1/J2/J3	81-83
KZ1000K1/K2 LTD	81-82
KZ1000M1/M2 CSR	81-82
KZ1000P1-P22 Police	82-03
KZ1000P24 Police	2005
KZ1000R1/R2 Replica	82-83
KZ1100A1/A2/A3 Shaft	81-83
KZ1100B1/B2 GPz	81-82
KZ1100D1/D2 Spectre	82-83
KZ1100L1 LTD	1983
ZN1100B1/B2 LTD	84-85
KZ1300A1/A2/A3/A4	79-82
KZ1300B2 Touring	1980
ZN1300A1-A6 Voyager	83-87

## Kawasaki Dual Sport & Offroad

KL600A1/B1/B2 KLR600	84-86
KL650A1-A19 KLR650	87-05
KL650A6F/A7F/A8F/A9F KLR650	06-09
KL650EAF/EBF/ECF/EDF KLR650	10-13
KL650B2/B3 Tengai KLR650	90-91
KLX650A1/A2/A3/D1 Offroad	93-96
KLX650C1/C2/C3/C4 Dual Sport	93-96

## Yamaha Street

XS400J/K Maxim	82-83
XS400RJ/RK Seca	82-83
XJ550H/J/K Maxim	81-83
XJ550RH/RJ/RK Seca	81-83
FJ600L/LC/N/NC	84-85
FZ600S/SC/T/TC/U/UC	86-88
YX600S/SC-A/AC Radian	86-90
XJ650G/H/J/K Maxim	80-83
XJ650LH Midnight Maxim	1981
XJ650RJ Seca	1982
XJ650LJ/LK Seca Turbo	82-83
XJ700N/NC/S/SC Maxim	85-86
XJ750J/K Maxim	82-83
XJ750MK Midnight Maxim	1983
XJ750RH/RJ/RK Seca	81-83
XS750D/2D/E/F	77-79
XS750SE/SF Special	78-79
XS850G/H	80-81
XS850LG/LG Midnight Special	80-81
XS850SG/SH Special	80-81
XJ900RK Seca	1982
XJ1100J Maxim	1982
XS1100E/F/G/H	78-81
XS1100LG/LH Midnight Special	80-81
XS1100SF/SG/SH Special	79-81



950-437

950-438



## 29.5mm Valve Adjustment Shim Kit

Sold as dealer kit and in individual sizes. Individual sizes sold each. See model application list on next column.

### Suzuki 29.5mm Diameter

Dealer Shim Kit 2.30mm - 3.00mm

Order No. **035-020**

Includes storage box and qt 2 each size of the following:

2.30, 2.35, 2.40, 2.45, 2.50, 2.55, 2.60, 2.65, 2.70, 2.75, 2.80, 2.85, 2.90, 3.00.

Valve Shim Storage Box

Order No. **008-001**

## 29.5mm Valve Adjustment Shims

Sold each. Sizes available from 2.30mm - 3.00mm thickness.

Size	Order No.	Size	Order No.
2.30mm	<b>035-519</b>	2.65mm	<b>035-526</b>
2.35mm	<b>035-520</b>	2.70mm	<b>035-527</b>
2.40mm	<b>035-521</b>	2.75mm	<b>035-528</b>
2.45mm	<b>035-522</b>	2.80mm	<b>035-529</b>
2.50mm	<b>035-523</b>	2.85mm	<b>035-530</b>
2.55mm	<b>035-524</b>	2.90mm	<b>035-531</b>
2.60mm	<b>035-525</b>	3.00mm	<b>035-533</b>



## APE Kawasaki Cam Cover Caps

Owners of race only Kawasaki's using the popular "J model" or GPZ1100 cylinder head can now remove the smog hose caps without leaving those ugly holes in the valve cover. The APE Billet caps are CNCed for perfect fit and stunning good looks. They fit all 1000s and 1100s with smog hoses in the cam cover. Sold in pairs, with allen bolts.

APE No. KCK1100

Order No. **875-600**

## Suzuki

Model	Year
GS400B/XB/C/XC	80-82
GS425EN/LN/N	1983
GS450ET/EX/EZ/ED	80-83
GS450GAZ/GAD	82-83
GS450GAF	1985
GS450LT/LX/LZ/LD	80-83
GS450LF/LG/LH/LJ	85-88
GS450ST/SX	80-81
GS450TX/TXZ/TZ/TXD	84-86
GS500EK/EL/EM/EN/EP/ER/ES/ET/EV/EW/EX/EY	89-00
GS500EK1/EK2	01-02
GS500FK4/FK5/FK6/FK7/FK8/FK9	04-09
GS500HK7/HK8/HK9	1979
GS550B/C/EC/N/EN/ET	77-80
GS550MZ Katana	1982
GS550TT/TX	80-81
GR650D/XD Tempter	1983
GS650EX/EZ	81-82
GS650GX/GZ/GD	81-83
GS650GLX/GLZ/GLD	81-83
GS650MD Katana	1983
XN85 Turbo	1983
GS750B/C/N/EN/EN	77-79
GS750ET/EX/EZ	80-82
GS750ED/ESD	1983
GS750SD Katana	82-83
GS750TZ/TD	82-83
GS850GN/GT//GX/GZ	80-82
GS850GLT/GLX/GLZ	81-83
GS1000C/EC/N/EN/ET	78-80
GS1000GT/GLT/GX/GLX	80-81
GS1000LN	1979
GS1000SN/ST	79-80
GS1000SZ Katana	1982
GS1100ED/ESD	1983
GS1100ET/EX/EZ	80-82
GS1100GZ/GLZ/GX/GLX	82-83
GS1100GKZ/GK2/GKD/GKE	82-84
GS1100SD Katana	1983



## APE Suzuki GS1100 Breather Block Off Plate

Get rid of that OEM breather cover on GS1100s and have a flat top on the valve cover for proper air box fitment, or just plain great looks. CNC machined from billet stock means it won't crack like the OEM part does.

APE No. SBC1100

Order No. **875-635**

# Engine Valves



## Vesrah Engine Valves

Sudco offers high performance engine valves manufactured in Japan to the highest quality standards by Fuji. All valves feature advanced technology, and tuff tride treatment for a superior product, with high resistance to wear, burn oxidation and corrosion. **Made in Japan.** Valves are sold each. Order per quantity required.

### Honda Street

Model	Year	Intake No.	Exhaust No.
CB125S	76-85	622-1014I	622-1014E
CB750A Automatic	76-77	622-1002I	622-1002E
CB750C Custom	80-82	622-1003I	622-1003E
CB750F Super Sport	75-76	622-1002I	622-1002E
CB750F Super Sport	79-82	622-1003I	622-1003E
CB750K D-K5/K	69-77	622-1002I	622-1002E
CB750K	79-82	622-1003I	622-1003E
CB750L LTD	1979	622-1003I	622-1003E
CB750SC Nighthawk	82-83	622-1003I	622-1003E
VF750C V45 Magna	82-83	622-030I	622-030E
VF750S V45 Sabre	82-83	622-030I	622-030E
CB900C Custom	80-82	622-1006I	622-1006E
CB900F Super Sport	81-82	622-1006I	622-1006E
CB1000C Custom	1983	622-1006I	622-1006E
CBX	79-82	622-1003I	622-1003E
CB1100F Super Sport	1983	622-1006I	622-1006E

### Honda ATV

ATC185	1980	622-1014I	622-1014E
ATC185S	81-83	622-1014I	622-1014E
ATC200	81-83	622-1014I	622-1014E
ATC200E	82-83	622-1014I	622-1014E
ATC200ES	1984	622-1014I	622-1014E
ATC200M	84-85	622-1014I	622-1014E
ATC200S	84-86	622-1014I	622-1014E
ATC200X	83-85	622-1014I	622-1014E
ATC200X	86-87	622-1024I	622-1024E
TRX200 Fourtrax 200	1984	622-1014I	622-1014E
TRX200 Fourtrax 200	90-91	622-1014I	622-1014E
TRX200D Fourtrax 200 Type II	91-97	622-1024I	622-1024E
TRX200SX Fourtrax	86-87	622-1024I	622-1024E
ATC250ES	85-87	622-1016I	622-1016E
ATC250SX	85-87	622-1016I	622-1016E
TRX250 Fourtrax	85-87	622-1016I	622-1016E
TRX250X Fourtrax	87-88	622-1026I	622-1026E
TRX250X Fourtrax	91-92	622-1026I	622-1026E
TRX300 Fourtrax 300	88-00	622-1020I	622-1016E
TRX300EX Fourtrax 300EX	93-00	622-1026I	622-1026E
TRX300EX Sportrax300EX	01-08	622-1026I	622-1026E
TRX300FW Fourtrax 300 4x4	1988	622-1020I	622-1016E
TRX300FW Fourtrax 300 4x4	90-00	622-1020I	622-1016E
TRX400EX Fourtrax 400EX	99-00	_____	_____
TRX400EX Fourtrax 400EX	01-05	_____	_____
TRX500FA Fourman Rubicon	01-05	_____	_____
TRX500FGA Fourman Rubicon	04-05	_____	_____

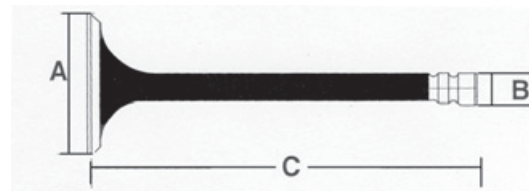

### Honda Dual Sport & Offroad

Model	Year	Intake No.	Exhaust No.
XL125S	79-82	622-1014I	622-1014E
XL125S	1984	622-1014I	622-1014E
XL185S	79-83	622-1014I	622-1014E
XR185	1979	622-1014I	622-1014E
XL200R	83-84	622-1014I	622-1014E
XR200	80-84	622-1014I	622-1014E
XR200R	81-83	622-1014I	622-1014E
XR200R	86-88	622-1014I	622-1014E
XR200R	90-91	622-1014I	622-1014E
XR200R	93-03	622-1014I	622-1014E
XR400R	96-04	_____	_____

### Kawasaki Street

KZ200A1/A2	78-79	622-4012I	622-4012E
KL250A1/A1A/A2	78-79	622-610I	622-610E
KL250A3/A4	80-81	622-4011I	622-4011E
KL250C1/C2	83-84	622-4011I	622-4011E
KL250D2-D22 KLR250	85-05	622-4018I	622-4018E
KZ250D1 LTD	1980	622-4011I	622-4011E
KZ250D2 CSR	1981	622-4011I	622-4011E
KZ250L1 CSR	1982	622-4011I	622-4011E
KZ250W1 LTD	1983	622-4011I	622-4011E
EX305B1 GPz	1983	622-4020I	622-4020E
KLX400A1 KLX400SR Dual Sport	2003	_____	_____
KZ400B1/B2	78-79	622-604I	622-604E
KZ400H1 LTD	1979	622-604I	622-604E
EN450A LTD454	85-90	622-4018I	622-4018E
EN500A1-A7 Vulcan	90-96	622-4018I	622-4018E
EN500C1-C9F Vulcan LTD	96-09	622-4018I	622-4018E
EN500C6F-C8F Vulcan 500 LTD	06-08	622-4018I	622-4018E
EX500A1-A7 Ninja 500R	87-93	622-4018I	622-4018E
EX500D1/D2/D3 Ninja 500	94-96	622-4018I	622-4018E
EX500D4-D9F Ninja 500R	97-09	622-4018I	622-4018E
EX500D6F/D7F/D8F Ninja 500R	06-08	622-4018I	622-4018E
KZ550A1/A2/A3	80 82	_____	_____
KZ550C1/C2/C3/C4 LTD	80-83	_____	_____
KZ550D1 GPz	1981	_____	_____
KZ550F1 Spectre	1983	_____	_____
KZ550F2 LTD	1984	_____	_____
KZ550H1/H2 GPz	82-83	_____	_____
KZ550M1 LTD	1983	_____	_____
ZR550B1/B2/B3/B4	90-93	_____	_____
ZX550A1/A2 GPz	84-85	_____	_____
KL600A1 KLR600 Dual Sport	1984	622-615I	_____
KL600B1/B2 KLR600 Dual Sport	85-86	622-615I	_____
ZL600A1/A2 Eliminator	85-86	622-4023I	622-4023E
ZL600B2/B3 Eliminator	96-97	_____	622-4018E
ZX600A1/A2/A3 Ninja 600R	85-87	622-4023I	622-4023E
ZX600B1 Ninja 600RX	1987	622-4023I	622-4023E
ZX600C1-C10 Ninja 600R	88-97	622-4023I	622-4023E
KL650A1-EBF KLR650	87-11	622-4015I	_____
KL650A6F KLR650	2006	622-4015I	_____
KL650B1/B2 Tengai KLR650	90-91	622-4015I	_____
KLX650C1/C2/C3/C4 Dual Sport	93-96	622-4038I	622-4038E
KZ650B1/B2/B2A/B3	77-79	622-4008I	_____
KZ650C1/C2/C3	77-79	622-4008I	_____



## Kawasaki Street

Model	Year	Intake No.	Exhaust No.
KZ650C1/C2/C3 Custom	77-79	622-4008I	—————
KZ650I/D1A/D2 SR	78-79	622-4008I	—————
KZ650E1 LTD	1980	622-4008I	—————
KZ650F1	1980	622-4008I	—————
VN750A2-A6F Vulcan 750	86-06	622-4017I	622-4017E
VN750A6F Vulcan 750	2006	622-4017I	622-4017E
ZI/A/B-900	73-75	622-4001I	622-4001E
KZ900A4/A5	76-77	622-4001I	622-4001E
KZ900B1 LTD	1976	622-4001I	622-4001E
ZL900A1/A2 Eliminator	85-86	622-4018I	622-4018E
ZX900A1/A2/A3 Ninja 900R	84-86	622-4018I	622-4018E
KZ1000A1/A2	77-78	622-4003I	622-4003E
KZ1000A3/A3A/A4 MKII	79-80	622-4003I	622-4003E
KZ1000B1/B2/B3/B4 LTD	77-80	622-4003I	622-4003E
KZ1000C1-C4 Police	78-81	622-4003I	622-4003E
KZ1000D1 Z1R	1978	622-4003I	622-4003E
KZ1000D3 Z1R	1980	622-4003I	622-4003E
KZ1000E1/E2 Shaft ST	79-80	622-4003I	622-4003E
KZ1000G1 LTD Classic	1980	622-4003I	622-4003E
KZ1000J1/J2/J3	81-83	622-4005I	622-4005E
KZ1000K1/K2 LTD	81-82	622-4005I	622-4005E
KZ1000M1/M2 CSR	81-82	622-4005I	622-4005E
KZ1000P1-P22 /Police	82-03	622-4005I	622-4005E
KZ1000P24 Police	2005	622-4005I	622-4005E
KZ1000R1/R2 Replica	82-83	622-4005I	622-4005E
ZG1000A1-A20 Concours	86-05	622-4018I	622-4018E
ZG1000A6F	2006	622-4018I	622-4018E
ZL1000A1 Eliminator	1987	622-4018I	622-4018E
ZX1000A1/A2 Ninja 1000R	86-87	622-4018I	622-4018E
KZ1100A1/A2/A3 Shaft	81-83	622-4005I	622-4005E
KZ1100B1/B2 GPz	81-82	622-4005I	622-4005E
KZ1100D1/D2 Spectre	82-83	622-4005I	622-4005E
KZ1100L1 LTD Shaft	1983	622-4005I	622-4005E
ZN1100B1/B2 LTD	84-85	622-4015I	622-4015E
ZX1100A1/A2 GPz	83-84	622-4015I	622-4015E
ZX1100C1/C2/C3/C4 Ninja ZX-11	90-93	622-4031I	622-4032E
VN1500A1-A9 Vulcan 88	87-90	622-4024I	622-4024E
VN1500A10/A11/A12 /A13 Vulcan1500	96-99	622-4024I	622-4024E
VN1500B1/B2/B3/B4 Vulcan 88 SE	87-90	622-4024I	622-4024E
VN1500C3/C4 Vulcan L	96-97	622-4024I	622-4024E
VN1500D1/D2 Classic	96-97	622-4024I	622-4024E
VN1500E1-E4 Classic	98-01	622-4024I	622-4024E
VN1500G1/G2/G3 Nomad	99-01	622-4024I	622-4024E
VN1500J1/J2 Drifter	99-00	622-4024I	622-4024E
VN1500L1-L4 Vulcan Nomad F.I.	00-04	622-4024I	622-4024E
VN1500N1-N3 Vulcan Classic F.I.	00-02	622-4024I	622-4024E
VN1500N4 Vulcan 1500 Classic	2005	622-4024I	622-4024E
VN1500N6F Vulcan 1500 Classic	2006	622-4024I	622-4024E
VN1500R1-R5 Vulcan 1500 Drifter	01-05	622-4024I	622-4024E
VN1500T6F Vulcan 1500 Classic	2006	622-4024I	622-4024E
VN1600A1-A8F	03-08	622-4024I	622-4024E
Vulcan 1600 Classic			
VN1600D1/D7F Vulcan 1600 Nomad	05-07	622-4024I	622-4024E
VN1600E6F Vulcan 1600 Classic	2006	622-4024I	622-4024E

## Kawasaki ATV

KLT160A1	1985	622-616I	622-616E
KLF185A1-A4 Bayou	85-88	622-616I	622-616E
KLT185A1/A2 Bayou	85-86	622-616I	622-616E
KLT200A1-A4/A4A	81-83	622-4011I	622-4011E
KLT200B1	1983	622-4011I	622-4011E
KLT200C1/C2	83-84	622-4011I	622-4011E
KLF220A1-A15 Bayou 220	88-02	—————	—————
KLF250A1/A2/A3/A6F Bayou 250	03-06	—————	—————
KLT250A1/A2	82-83	622-4011I	622-4011E
KLT250C1/C2/C3	83-85	622-4011I	622-4011E
KLT250P1 Police	1984	622-4011I	622-4011E

## Kawasaki ATV

Model	Year	Intake No.	Exhaust No
KSF250A1-A17 Mojave 250	87-03	622-4018I	622-4018E
KSF250A18 KFX250 Mojave	2004	622-4018I	622-4018E
KEF300A1-A6 Lakota	95-00	622-4011I	622-4011E
KEF300B1/B2/B3 Lakota Sport	01-03	622-4011I	622-4011E
KLF300A1/A2 Bayou	86-87	622-4011I	622-4011E
KLF300B1-B17 Bayou 300	88-04	622-4011I	622-4011E
KLF300C1-C16 Bayou 300 4x4	89-04	622-4011I	622-4011E
KVF300A1-A4 Prairie 3004 x4	99-02	622-4011I	622-4011E
KVF300B1-B4 Prairie 300	99-02	622-4011I	622-4011E
KVF360A1-A6F Prairie 360 4x4	03-09	—————	—————
KVF360B1/B2/B3/B6F Prairie 360	03-09	—————	—————
KVF360C1 Prairie 360 4x4	03-05	—————	—————
Advantage Classic			
KVF360C2/C3/C6F Prairie 360 4x4	04-10	—————	—————
Hardwoods Green HD			
KLF400B1-B7 Bayou 400 4x4	93-99	—————	—————
KSF400A1/A2/A3 KFX400	03-06	—————	—————
KSF400A6F KFX400	2006	—————	—————
KVF400A1/A2 Prairie 400 4x4	97-98	—————	—————
KVF400B1 Prairie 400	1998	—————	—————
KVF400C1-C4 Prairie 400 4x4	99-02	—————	—————
KVF400D1/D2/D3/D4 Prairie 400	99-02	—————	—————
KVF650A1/A2 Prairie 650 4x4	02-03	—————	—————
KVF650B1/B2 Prairie 650 4x4	02-03	—————	—————
Advantage Classic			
KVF650D1Brute Force 650 4x4	2005	—————	—————
KVF650D6F Brute Force 650 4x4	2006	—————	—————
KVF650E1 Brute Force 650 4x4	2005	—————	—————
Realtree Hardwoods Green HD			
KVF650E6F-E9F Brute Force 650 4x4	06-09	—————	—————
Realtree Hardwoods Green HD			
KVF650F6F Brute Force 650 4x4i	2006	—————	—————
KSV700A1-A9F KFX700 V-Force	04-09	—————	—————
KSV700B1-B9F KFX700 V-Force	04-09	—————	—————
KSV700C6F	2006	—————	—————
KVF700A1/A2/A6F Prairie 700 4x4	04-06	—————	—————
KVF700B1/B2 Prairie 700 4x4	04-05	—————	—————
Hardwoods Green HD			
KVF700D1/D6F Prairie 700 4x4	05-06	—————	—————
Team Green Special Edition			
KVF750A1 Brute Force 750 4x4i	2005	—————	—————
KVF750A6F Brute Force 750 4x4i	2006	—————	—————
KVF750B1 Brute Force 750 4x4i	2005	—————	—————
Real Tree Hardwoods Green HD			
KVF750B6F Brute Force 750 4x4i	2006	—————	—————
Real Tree Hardwoods Green HD			

## Kawasaki Dual Sport & Offroad

KL250A1/A1A/A2	78-79	622-610I	622-610E
KL250A3/A4	80-81	622-4011I	622-4011E
KL250C1/C2	83-84	622-4011I	622-4011E
KL250D2-D22 KLR250	85-05	622-4018I	622-4018E
KLX250D2/D3/D4 KLX250R	94-96	—————	—————
KLX250H6F-H7F KLX250S	06-07	—————	—————
KLX300A2-A7F KLX300R	97-07	—————	—————
KLX300A6F KLX300R	2006	—————	—————
KLX400A1 KLX400SR Dual Sport	2003	—————	—————
KLX400B1 KLX400R Offroad	2003	—————	—————
KL600A1 KLR600	1984	622-615I	—————
KL600B1/B2 KLR600	85-86	622-615I	—————
KL650A1-A19 KLR650	87-05	622-4015I	—————
KL650A6F KLR650 Dual Sport	06-07	622-4015I	—————
KL650B1/B2 Tengai KLR650	90-91	622-4015I	—————
KLX650A1/A2/A3 KLX650R	93-95	622-4038I	622-4038E
KLX650C1/C2/C3/C4 Dual Sport	93-96	622-4038I	622-4038E
KLX650D1 KLX650R	1996	622-4038I	622-4038E

# Vesrah Engine Valves

## Suzuki Street

Model	Year	Intake No.	Exhaust No
SP100D Dual Sport	1983	————	————
GN125Z/D	82-83	————	<b>622-3012E</b>
SP125Z/D Dual Sport	82-83	————	————
DR250SL-SER Dual Sport	90-95	<b>622-3026I</b>	<b>622-3026E</b>
GN250Z/D	82-83	————	————
GN250F	1985	————	————
GN250J	1988	————	————
SP250Z/D Dual Sport	82-83	————	<b>622-406E</b>
SP250F Dual Sport	1985	————	<b>622-406E</b>
DR350L/M/N/P/R/S/T/V/W/X	90-99	<b>622-3028I</b>	<b>622-3028E</b>
DR350SL-SEX Dual Sport	90-99	<b>622-3028I</b>	<b>622-3028E</b>
GS550B/C/EC/N/EN	77-79	————	<b>622-433E</b>
GS550ET	1980	————	<b>622-433E</b>
GS550LN/LT/LX/LZ	79-82	————	<b>622-433E</b>
GS550MZ Katana	1982	————	<b>622-433E</b>
GS550TX	1981	————	<b>622-433E</b>
GSF600ST/SV/SW/SX/SY Bandit	96-00	<b>622-3023I</b>	<b>622-3023E</b>
GSF600SK1/SK2/SK3 Bandit	01-03	<b>622-3023I</b>	<b>622-3023E</b>
GXS600FJ/FK/FL/FM Katana	88-91	<b>622-3023I</b>	<b>622-3023E</b>
GXS600FN-FV Katana	92-97	<b>622-3034I</b>	<b>622-3034E</b>
GXS600F W-K6 Katana	88-06	<b>622-3023I</b>	<b>622-3023E</b>
GXS-R600WN/WP	92-93	<b>622-3029I</b>	<b>622-3029E</b>
RF600RR/RS/RT	94-96	<b>622-3029I</b>	<b>622-3029E</b>
DR650S T-L1 Dual Sport	96-11	<b>622-3021I</b>	————
GS650EX/EZ	81-82	————	<b>622-433E</b>
GS650GX/GZ/GD	81-83	————	<b>622-433E</b>
GS650GLX/GLZ/GLD	81-83	————	<b>622-433E</b>
GS650MD Katana	1983	————	<b>622-433E</b>
XN85D Turbo	1983	————	<b>622-433E</b>
SV650 X-L0	99-10	<b>622-3036I</b>	————
SV650S X-L0	99-10	<b>622-3036I</b>	————
GS750ET/EX/EZ	80-82	<b>622-3001I</b>	<b>622-3001E</b>
GS750LT/LX	80-81	<b>622-3001I</b>	<b>622-3001E</b>
GS750TZ/TD	82-83	<b>622-3001I</b>	<b>622-3001E</b>
GXS750FK-FV Katana	89-97	<b>622-3022I</b>	<b>622-3022E</b>
GXS-R750G/H	86-87	<b>622-3019I</b>	<b>622-3019E</b>
GXS-R750RG	1986	<b>622-3019I</b>	<b>622-3019E</b>
GXS-R750J/K	88-89	<b>622-3022I</b>	<b>622-3022E</b>
GXS-R750WP/WR/WS	93-95	<b>622-3027I</b>	<b>622-3027E</b>
GXS-R750TV/W/X	96-99	<b>622-3038I</b>	<b>622-3027E</b>
GXS-R750Y/K1-K3	00-03	<b>622-3045I</b>	<b>622-3045E</b>
RF900RR/RS/RT/RV	94-97	<b>622-3035I</b>	<b>622-3027E</b>
GS1000C/EC/N/EN/ET	78-80	————	<b>622-3007E</b>
GS1000GT/GLT/GX/GLX	81-82	————	<b>622-3007E</b>
GS1000LN	1979	————	<b>622-3007E</b>
GS1000SN/ST	79-80	————	<b>622-3007E</b>
GS1000SZ Katana	1982	<b>622-3008I</b>	<b>622-3008E</b>
GXS-R1000K1/K2/K3/K4	01-04	<b>622-3045I</b>	<b>622-3045E</b>
GS1100ET/EX/EZ/ED/ESD	80-83	<b>622-3008I</b>	<b>622-3008E</b>
GS1100GZ/GLZ/GD/GLD	82-83	————	<b>622-3007E</b>
GS1100GKZ/GK2/GKD/GKE	82-84	————	<b>622-3007E</b>
GS1100LT	1980	<b>622-3008I</b>	<b>622-3008E</b>
GS1100SD Katana	1983	<b>622-3008I</b>	<b>622-3008E</b>
GXS1100FJ-FP Katana	88-93	<b>622-3018I</b>	<b>622-3018E</b>
GXS1100GM/GN/GP Shaft	91-93	<b>622-3018I</b>	<b>622-3018E</b>
GXS-R1100G/H/J/K/L	86-90	<b>622-3018I</b>	<b>622-3018E</b>
GXS-R1100M/N	91-92	<b>622-3032I</b>	<b>622-3032I</b>
GXS-R1100WP/WR/WS	93-95	<b>622-3036I</b>	<b>622-3036E</b>
GXS-R1100WT/WV/WW	96-98	<b>622-3036I</b>	<b>622-3036E</b>
GSF1200SV/SW/SX/SY Bandit	97-00	<b>622-3018I</b>	<b>622-3018E</b>
GSF1200S K1-K2 Bandit	01-02	<b>622-3018I</b>	<b>622-3018E</b>
GSF1200SAV Bandit 12/21	1997	<b>622-3018I</b>	<b>622-3018E</b>

## Suzuki ATV

Model	Year	Intake No.	Exhaust No
ALT125D/E	83-84	<b>622-405I</b>	————
LT230EH/EJ/EK/EL Quadrunner	87-90	<b>622-3016I</b>	<b>622-3016E</b>
LT230EM/EN/EP Quadrunner	91-93	<b>622-3016I</b>	<b>622-3016E</b>
LT230GEF/GEG Quadrunner	85-86	<b>622-3016I</b>	<b>622-3016E</b>
LT230SF/SG/SH/SJ Quadrunner	85-88	<b>622-3016I</b>	<b>622-3016E</b>
LT-F230G/H	86-87	<b>622-3016I</b>	<b>622-3016E</b>
LT250EFF/EFEG Quadrunner	85-86	————	<b>622-406E</b>
LT-F250J/K/L/M/N/P	88-93	<b>622-3021I</b>	<b>622-3016E</b>
LT-F250R/S/T/V/W/X/Y/K1	94-01	<b>622-3021I</b>	<b>622-3016E</b>
LT-F250 K2-L2 Ozark	02-12	<b>622-3016I</b>	<b>622-3016E</b>
LT-F250FX/FY/FK1/FK2	99-02	<b>622-3021I</b>	<b>622-3016E</b>
LT-Z250 K4-K9 Quadrunner	04-09	<b>622-3016I</b>	<b>622-3016E</b>
LT-4WDH/WDJ/WDK Quad 4x4	87-89	<b>622-3021I</b>	<b>622-3016E</b>
LT-4WDL/WDM/WDN Quad 4x4	90-92	<b>622-3021I</b>	<b>622-3016E</b>
LT-4WDP/WDR/WDS Quad 4x4	93-95	<b>622-3021I</b>	<b>622-3016E</b>
LT-4WDT/WDV/WDW Quad 4x4	96-98	<b>622-3021I</b>	<b>622-3016E</b>
LT300EH/EJ/EK	87-89	————	<b>622-406E</b>
LT-F300FX/FY/K1/K2 King Quad	99-02	<b>622-3021I</b>	<b>622-3016E</b>
LT-F4WDXM/N/P/R King Quad	91-94	<b>622-3021I</b>	<b>622-3016E</b>
LT-F4WDXS/T/V/W King Quad	95-98	<b>622-3021I</b>	<b>622-3016E</b>
LT-400K2/K3/K4 Eiger 2WD	02-03	<b>622-3028I</b>	<b>622-3028E</b>
LT-A400FK2/FK3 Eiger Auto 4WD	02-03	<b>622-3028I</b>	<b>622-3028E</b>
LT-A400F K4-K7 Eiger Auto 4WD	04-07	<b>622-3028I</b>	<b>622-3028E</b>
LT-A400FK3 Eiger Auto 4WD	2003	<b>622-3028I</b>	<b>622-3028E</b>
LT-A400FK4 Eiger Auto 4WD	2004	<b>622-3028I</b>	<b>622-3028E</b>
LT-A400K2-K8 Eiger Auto 2WD	02-08	<b>622-3028I</b>	<b>622-3028E</b>
LT-F400FK2/FK3/FK4 Eiger 4WD	02-04	<b>622-3028I</b>	<b>622-3028E</b>
LT-F400 K2-L0 Eiger 2WD	02-10	<b>622-3028I</b>	<b>622-3028E</b>
LT-Z400K3/K4/K5 Quad Sport	03-05	————	————
LT-A500FY/K1	00-01	<b>622-3028I</b>	<b>622-3028E</b>
LT-A500FK2/FK3 Vinson 4WD	02-03	<b>622-3028I</b>	<b>622-3028E</b>
LT-A500FK4/FCK4 Vinson 4WD	2004	<b>622-3028I</b>	<b>622-3028E</b>
LT-A500FK5/K7 Vinson 4WD	05-07	<b>622-3028I</b>	<b>622-3028E</b>
LT-F500FK3 Vinson Manual 4WD	2003	<b>622-3028I</b>	<b>622-3028E</b>
LT-F500FK4 Vinson Manual 4WD	2004	<b>622-3028I</b>	<b>622-3028E</b>
LT-F500FK5 Vinson Manual 4WD	2005	<b>622-3028I</b>	<b>622-3028E</b>
LT-F500FW/FX/FY Quadrunner	98-00	<b>622-3028I</b>	<b>622-3028E</b>
LT-F500FK1/FK2 Quadrunner	01-02	<b>622-3028I</b>	<b>622-3028E</b>

## Suzuki Dual Sport & Offroad

DR100D/E	83-84	————	————
SP100D Dual Sport	1983	————	————
DR125Z/D/E	82-84	————	————
SP125Z/D Dual Sport	82-83	————	————
DR250Z/D	82-83	————	<b>622-406E</b>
DR250F	1985	————	<b>622-406E</b>
DR250L/M/N/P	90-93	<b>622-3026I</b>	<b>622-3026E</b>
DR250SL-SER Dual Sport	90-95	<b>622-3026I</b>	<b>622-3026E</b>
SP250Z/D Dual Sport	82-83	————	<b>622-406E</b>
SP250F Dual Sport	1985	————	<b>622-406E</b>
DR350L/M/N/P/R/S/T/V/W/X	90-99	<b>622-3028I</b>	<b>622-3028E</b>
DR350SL-SEX Dual Sport	90-99	<b>622-3028I</b>	<b>622-3028E</b>
DR-Z400Y/K1/K2/K3/K4/K5	00-04	————	————
DR-Z400EY-K6	00-06	————	————
DR-Z400SY-L0 Dual Sport	00-12	————	————
DR650SET-L1 Dual Sport	96-11	<b>622-3021I</b>	————

## Yamaha Street

Model	Year	Intake No.	Exhaust No.
SR185H/J Exciter	81-82	622-2013I	622-2013E
XS360C/D/2D	76-77	622-235I	622-235E
XS400D/E/2E/F/2F	77-79	622-235I	622-235E
XS400G/H Special II	80-81	622-235I	622-235E
XS400SG/SH Special	80-81	622-235I	622-235E
XS400SJ Heritage Special	1982	622-235I	622-235E
XS400J/K Maxim	82-83	622-2011I	622-2011E
XS400RJ/RK Seca	82-83	622-2011I	622-2011E
SR500E/F/G/H	78-81	622-2011I	622-2007E
XJ550H/J/K Maxim	81-83	622-205I	622-205E
XJ550RH/RJ/RK Seca	81-83	622-205I	622-205E
XZ550R/J/RK Vision	82-83	622-236I	622-205E
XJ650G/H/J/K Maxim	80-83	622-2004I	622-2004E
XJ650LH Midnight Maxim	1981	622-2004I	622-2004E
XJ650LJ/LK Seca Turbo	82-83	622-2004I	622-2004E
XJ650RJ Seca	1982	622-2004I	622-2004E
XJ750J/K Maxim	82-83	622-2004I	622-2004E
XJ750MK Midnight Maxim	1983	622-2004I	622-2004E
XJ750RH/RJ/RK Seca	81-83	622-2004I	622-2004E
XS750D/2D/E/F	77-79	622-2011I	622-2011E
XS750SE/SF Special	78-79	622-2011I	622-2011E
XV750H/J/K Virago	81-83	————	————
XV750MK Midnight Virago	1983	————	————
XV750U/UC-G/GC Virago	88-95	————	————
XV750H1/H1C1-K1/KC1 Virago	96-98	————	————
XS850G/H	80-81	622-2011I	622-2011E
XS850LG/LH Midnight Special	80-81	622-2011I	622-2011E
XS850SG/SH Special	80-81	622-2011I	622-2011E
XV920J/K Virago	82-83	622-2011I	622-2011E
XV920MK Midnight Virago	1983	622-2011I	622-2011E
XV920RH/RJ	81-82	622-2011I	622-2011E
XV1000L/LC/N/NC Virago	84-85	622-2011I	622-2011E
XJ1100J Maxim	1982	622-2031I	622-2031E
XS1100E/F	78-79	622-2011I	622-2011E
XS1100G/H	80-81	622-2031I	622-2031E
XS1100LG/LH Midnight Special	80-81	622-2031I	622-2031E
XS1100SF Special	1979	622-2011I	622-2011E
XS1100SG/SH Special	80-81	622-2031I	622-2031E
XV1100S/SC-L/LC Virago	86-99	622-2011I	622-2011E
XV1100SH/SHC-SK/SKC Virago	96-98	622-2011I	622-2011E
XVS1100AM/AMC-AS/ASC	00-04	622-2011I	622-2011E
V-Star 1100 Classic			
XVS1100AT T/TC-Y/YC	03-09	622-2011I	622-2011E
V-Star 1100 Silverado			
XVS1100AW T/TC-Y/YC	03-09	622-2011I	622-2011E
V-Star 1100 Classic			
XVS1100L/LC-T/TC	99-05	622-2011I	622-2011E
V-Star 1100 Custom			
VMX12N/NC-W1/W1C V-Max	85-07	622-2019I	622-2019E

## Yamaha ATV

YFM200N Moto-4	1985	622-2013I	622-2013E
YFM200DXS-DXW Moto-4	86-89	622-2013I	622-2013E
YTM200K/L/N Tri-Moto	83-84	622-2013I	622-2013E
YTM200N Tri-Moto	1985	622-2013I	622-2013E
YFM225S/T/U Moto-4	86-88	622-2013I	622-2013E
YTM225DRN/DRS Tri-Moto	85-86	622-2013I	622-2013E
YTM225DXK/DXL/DXN Tri-Moto	83-85	622-2013I	622-2013E
YTM200EK/EL/ERN Tri-Moto	83-85	622-2013I	622-2013E
YFB250D/E/F/G/H Timberwolf	92-96	622-2013I	622-2013E
YFB250FWF-FWMC Timberwolf	94-00	622-2013I	622-2013E
YFB250UH/UJ/UK Timberwolf	96-98	622-2013I	622-2013E
YFM250W/A/B Moto-4	89-91	622-2013I	622-2013E
YFM250M/MC Beartracker	2000	622-2013I	622-2013E
YFM250XL/XLC-XS Beartracker	99-04	622-2013I	622-2013E
YFM350S Raptor	2004	622-2020I	622-2020E
YFM350RSET/RESV Raptor 350 SE	05-06	622-2020I	622-2020E

## Yamaha ATV

Model	Year	Intake No.	Exhaust No.
YFM350R T-Y Raptor	05-09	622-2020I	622-2020E
YFM350FAS/FAT Bruin 350 4x4	04-06	622-2020I	622-2020E
YFM350FAHS Bruin 350 Auto 4x4 Hardwood Camo	2004	622-2020I	622-2020E
YFM350FXP/FXR Wolverine	02-03	622-2020I	622-2020E
YFM350XT-XS/XSC Warrior	87-04	622-2020I	622-2020E
YFM350AS/AT Bruin 350 Auto 2WD	04-05	622-2020I	622-2020E
YFM350BAT/BAV Bruin 350 2WD	05-06	622-2020I	622-2020E
YFM350FAS/FAT Bruin 350 4WD	05-06	622-2020I	622-2020E
YFM350FAV-B Bruin 350 4WD	2006	622-2020I	622-2020E
YFM350FAV Bruin 350 4WD	2006	622-2020I	622-2020E
YFM350FAHS/T/V Bruin 4WD	04-06	622-2020I	622-2020E
YFM350FXG-FXN/FXNC Wolverine	95-01	622-2020I	622-2020E
YFM350FXS/FXT Wolverine	04-05	622-2020I	622-2020E
YFU1TW/YFU1W Pro-Hauler	1989	622-2013I	622-2013E
YFM400S Big Bear 400 2WD	2004	622-2020I	622-2020E
YFM400P Big Bear 400 2WD	2002	622-2020I	622-2020E
YFM400AM/AMC Kodiak2WD	2000	622-2020I	622-2020E
YFM400AR Kodiak4WD	2003	622-2020I	622-2020E
YFM400FM/FMC Big Bear 4WD	2000	622-2020I	622-2020E
YFM400FP Big Bear 4WD	2001	622-2020I	622-2020E
Real Tree			
YFM400FAM/FAMC/N/P/R/RB Kodiak 4WD Auto	00-03	622-2020I	622-2020E
YFM400FAHM/MC/N/NC Kodiak	00-01	622-2020I	622-2020E
YFM400FHP Big Bear 400 4WD	2002	622-2020I	622-2020E
YFM400FHAP Kodiak 4x4 Hunter	2002	622-2020I	622-2020E
YFM400FWE-FWL/FWLC Kodiak	93-90	622-2020I	622-2020E
YFM400FWR Big Bear	2003	622-2020I	622-2020E
YFM400FWAHM/MC Kodiak 4WD	2000	622-2020I	622-2020E
Realtree			
YFM400FVNM/MCN Big Bear 4WD	00-01	622-2020I	622-2020E
YFM400FVNHM/MCN Big Bear	00-01	622-2020I	622-2020E
Buckmaster			
YFM400HP Big Bear 2WD	2002	622-2020I	622-2020E
YFM400NM/NM/C/N Big Bear 2WD	00-01	622-2020I	622-2020E
YFM400NR Big Bear 2WD	2003	622-2020I	622-2020E
YFM400NHN Big Bear 2WD	2001	622-2020I	622-2020E

## Yamaha Dual Sport & Offroad

BW200N/S Big Wheel	85-86	622-2013I	622-2013E
BW200ES/ET/EU Big Wheel	86-88	622-2013I	622-2013E
TW200T/TC-B1 Trailway	87-12	622-2013I	622-2013E
XT200J/K/KC Dual Sport	82-83	622-2013I	622-2013E
TT225S/T	86-87	622-2013I	622-2013E
TT225L/LC/RM/RMC	99-00	622-2013I	622-2013E
TT-R225N/NC/P/PC/R/RC/S	01-04	622-2013I	622-2013E
XT225D/DC-V/V/C Serrow	92-07	622-2013I	622-2013E
TTR-230 T/TC-B	05-12	622-2013I	622-2013E
WR400FK/FL/FM	98-00	————	————
YZ400FK/FL	98-99	————	————
WR426FN/FP	01-02	————	————
YZ426FM/FN/FP	00-02	————	————
TT500C/D/E/F/G/H	76-81	————	622-2007E
XT500C/D/E/F/G/H Dual Sport	76-81	————	622-2007E
XT550J/K Dual Sport	82-83	622-208I	————

# Vesrah Engine Valves

## Sudco Part Number to OEM Cross Reference

### Honda

OEM Reference	Dimension- Head x Stem x Overall	Vesrah Reference	Order No.
14711-MB0-000	26.00 x 5.50 x 89.70mm	GG-1001-IN	<b>622-030I</b>
14721-MB0-000	23.00 x 5.50 x 89.40mm	GG-1001-IN	<b>622-030E</b>
14711-300-005	32.00 x 6.60 x 102.50mm	GG-1002-IN	<b>622-1002I</b>
14721-300-005	28.00 x 6.60 x 102.50mm	GG-1002-EX	<b>622-1002E</b>
14711-MA4-770	25.00 x 5.50 x 90.00mm	GG-1003-IN	<b>622-1003I</b>
14721-422-000	22.00 x 5.50 x 88.70mm	GG-1003-EX	<b>622-1003E</b>
14711-438-000	26.00 x 5.50 x 90.00mm	GG-1006-IN	<b>622-1006I</b>
14721-438-000	22.60 x 5.50 x 88.70mm	GG-1006-EX	<b>622-1006E</b>
14711-440-003	30.00 x 5.50 x 92.00mm	GG-1014-IN	<b>622-1014I</b>
14711-437-000	30.00 x 5.50 x 92.00mm	GG-1014-IN	<b>622-1014I</b>
14721-437-000	25.00 x 5.50 x 91.50mm	GG-1014-EX	<b>622-1014E</b>
14711-HA0-003	32.00 x 5.50 x 91.30mm	GG-1016-IN	<b>622-1016I</b>
14721-HA0-003	28.00 x 5.50 x 89.95mm	GG-1016-EX	<b>622-1016E</b>
14711-440-003	30.00 x 5.50 x 92.00mm	GG-1020-IN	<b>622-1020I</b>
14711-HB3-770	30.50 x 5.50 x 85.90mm	GG-1024-IN	<b>622-1024I</b>
14721-HB3-000	25.00 x 5.50 x 84.80mm	GG-1024-EX	<b>622-1024E</b>
14711-HC0-000	25.50 x 5.50 x 93.50mm	GG-1026-IN	<b>622-1026I</b>
14721-HC0-000	25.50 x 5.50 x 93.00mm	GG-1026-EX	<b>622-1026E</b>

### Kawasaki

12004-012	36.00 x 7.00 x 91.68mm	GG-4001-IN	<b>622-4001I</b>
12005-005	30.00 x 7.00 x 90.19mm	GG-4001-EX	<b>622-4001E</b>
12004-1010	36.00 x 7.00 x 91.68mm	GG-4003-IN	<b>622-4003I</b>
12005-1009	30.00 x 7.00 x 90.19mm	GG-4003-EX	<b>622-4003E</b>
12004-1013	37.00 x 7.00 x 64mm	GG-4005-IN	<b>622-4005I</b>
12005-1011	32.00 x 7.00 x 89.14mm	GG-4005-EX	<b>622-4005E</b>
12004-1001	35.00 x 7.00 x 94.49mm	GG-4006-IN	<b>622-604I</b>
12005-1001	35.00 x 7.00 x 93.03mm	GG-4006-EX	<b>622-604E</b>
12004-1011	33.00 x 7.00 x 92.80mm	GG-4008-IN	<b>622-4008I</b>
12005-008	28.00 x 7.00 x 92.50mm	GG-4008-EX	
12004-1016	28.00 x 5.50 x 91.30mm	GG-4009-IN	<b>622-4009I</b>
12004-1123	31.00 x 7.00 x 100.70mm	GG-4011-IN	<b>622-4011I</b>
12004-1137	31.00 x 7.00 x 100.70mm	GG-4011-IN	<b>622-4011I</b>
12005-1275	31.00 x 7.00 x 99.00mm	GG-4011-EX	<b>622-4011E</b>
12005-1005	31.00 x 7.00 x 99.00mm	GG-4011-EX	<b>622-4011E</b>
12004-018	36.00 x 7.00 x 100.50mm	GG-4012-IN	<b>622-610I</b>
12005-010	30.00 x 7.00 x 99.00mm	GG-4012-EX	<b>622-610E</b>
12004-1087	38.00 x 7.00 x 91.14mm	GG-4015-IN	<b>622-4015I</b>
12005-1016	32.50 x 7.00 x 88.50mm	GG-4015-EX	<b>622-4015E</b>
12004-1061	32.00 x 5.50 x 90.22mm	GG-4017-IN	<b>622-4017I</b>
12005-1064	28.00 x 5.50 x 90.09mm	GG-4017-EX	<b>622-4017E</b>
12004-1085	29.00 x 5.50 x 89.09mm	GG-4018-IN	<b>622-4018I</b>
12004-1079	29.00 x 5.50 x 89.09mm	GG-4018-IN	<b>622-4018I</b>
12005-1052	24.70 x 5.50 x 87.16mm	GG-4018-EX	<b>622-4018E</b>
12004-1086	38.00 x 7.00 x 90.64mm	GG-4019-IN	<b>622-615I</b>
12004-1051	30.00 x 5.50 x 89.20mm	GG-4020-IN	<b>622-616I</b>
12005-1051	26.00 x 5.50 x 88.50mm	GG-4020-EX	<b>622-616E</b>
12004-1075	21.50 x 5.00 x 80.60mm	GG-4023-IN	<b>622-4023I</b>
12004-1065	21.50 x 5.00 x 80.60mm	GG-4023-IN	<b>622-4023I</b>
12005-1062	19.00 x 5.00 x 79.30mm	GG-4023-EX	<b>622-4023E</b>
12004-1072	33.00 x 7.00 x 101.25mm	GG-4024-IN	<b>622-4024I</b>
12005-1268	33.00 x 7.00 x 101.25mm	GG-4024-EX	<b>622-4024E</b>
12004-1115	31.60 x 5.00 x 89.10mm	GG-4031-IN	<b>622-4031I</b>
12005-1240	27.00 x 5.00 x 88.83mm	GG-4031-EX	<b>622-4031E</b>
12004-1188	38.00 x 7.00 x 92.17mm	GG-4038IN	<b>622-4038I</b>
12005-1188	33.00 x 7.00 x 91.40mm	GG-4038-EX	<b>622-4038E</b>

### Suzuki

12911-45410	23.00 x 5.50 x 88.30mm	GG-3001-IN	<b>622-3001I</b>
12912-45410	20.00 x 5.50 x 87.90mm	GG-3001-EX	<b>622-3001E</b>
12912-47011	27.00 x 7.00 x 85.56mm	GG-3006-IN	<b>622-433E</b>
12911-49020	38.00 x 7.00 x 90.90mm	GG-3007-IN	<b>622-3007I</b>
12912-49020	38.00 x 7.00 x 89.10mm	GG-3007-EX	<b>622-3007E</b>
12911-49220	27.00 x 5.50 x 86.50mm	GG-3008-IN	<b>622-3008I</b>

## Sudco Part Number to OEM Cross Reference

### Suzuki

OEM Reference	Dimension- Head x Stem x Overall	Vesrah Reference	Order No.
12912-49220	27.00 x 5.50 x 86.50mm	GG-3008-EX	<b>622-3008E</b>
12911-05211	30.00 x 5.50 x 90.30mm	GG-3012-IN	<b>622-405I</b>
12912-38201	22.00 x 5.50 x 93.38mm	GG-3013-EX	<b>622-406E</b>
12911-31300		GG-3015-IN	<b>622-408I</b>
12912-31301		GG-3015-EX	<b>622-408E</b>
12911-18A00	32.00 x 5.50 x 88.66mm	GG-3016-IN	<b>622-3016I</b>
12911-05G00	32.00 x 5.50 x 88.66mm	GG-3016-IN	<b>622-3016I</b>
12912-18A00	28.00 x 5.50 x 87.84mm	GG-3016-EX	<b>622-3016E</b>
12911-06B02	28.50 x 5.00 x 85.60mm	GG-3018-IN	<b>622-3018I</b>
12912-06B00	25.00 x 5.00 x 84.99mm	GG-3018-EX	<b>622-3018E</b>
12911-27A03	26.00 x 5.00 x 88.17mm	GG-3019-IN	<b>622-3019I</b>
12912-27A01	24.00 x 5.00 x 87.74mm	GG-3019-EX	<b>622-3019E</b>
12911-19B00	33.00 x 5.50 x 88.57mm	GG-3021-IN	<b>622-3021I</b>
12911-17C02	28.00 x 5.00 x 87.42mm	GG-3022-IN	<b>622-3022I</b>
12912-17C00	25.00 x 5.00 x 86.73mm	GG-3022-EX	<b>622-3022E</b>
12911-19C00	23.00 x 5.00 x 88.67mm	GG-3023-IN	<b>622-3023I</b>
12912-19C00	20.00 x 5.00 x 88.42mm	GG-3023-EX	<b>622-3023E</b>
12911-17E00	27.00 x 4.50 x 96.46mm	GG-3027-IN	<b>622-3027I</b>
12912-17E01	24.00 x 4.50 x 96.71mm	GG-3027-EX	<b>622-3027E</b>
12911-14D01	30.60 x 5.00 x 93.05mm	GG-3028-IN	<b>622-3028I</b>
12911-14D10	30.60 x 5.00 x 93.05mm	GG-3028-IN	<b>622-3028I</b>
12912-14D01	27.00 x 5.00 x 92.55mm	GG-3028-EX	<b>622-3028E</b>
12911-18E00	25.50 x 4.50 x 96.96mm	GG-3029-IN	<b>622-3029I</b>
12912-18E00	25.50 x 4.50 x 97.01mm	GG-3029-EX	<b>622-3029E</b>
12911-41C00	28.50 x 5.00 x 87.84mm	GG-3032-IN	<b>622-3032I</b>
12912-41C00	25.00 x 5.00 x 87.17mm	GG-3032-EX	<b>622-3032E</b>
12911-19E00	23.00 x 5.00 x 90.85mm	GG-3034-IN	<b>622-3034I</b>
12912-19E00	20.00 x 5.00 x 90.60mm	GG-3034-EX	<b>622-3034E</b>
12911-31E00	28.00 x 4.50 x 96.80	GG-3035-IN	<b>622-3035I</b>
12911-46E00	31.00 x 4.50 x 94.66mm	GG-3036-IN	<b>622-3036I</b>
12912-46E00	27.00 x 4.50 x 94.41mm	GG-3036-EX	<b>622-3036E</b>
12911-33E00	29.00 x 4.50 x 96.11mm	GG-3038-IN	<b>622-3038I</b>
12911-35F00	29.00 x 4.00 x 95.43mm	GG-3045-IN	<b>622-3045I</b>
12912-35F00	24.00 x 4.00 x 95.56mm	GG-3045-EX	<b>622-3045E</b>

### Yamaha

1J7-12111-01-00	36.00 x 7.00 x 96.00mm	GG-2001-IN	<b>622-201I</b>
12R-12111-00-00	36.00 x 7.00 x 96.00mm	GG-2001-IN	<b>622-201I</b>
1J7-12121-00-00	31.00 x 7.00 x 95.00mm	GG-2001-EX	<b>622-201E</b>
12R-12121-00-00	31.00 x 7.00 x 95.00mm	GG-2001-EX	<b>622-201E</b>
4X7-12111-00-00	43.00 x 8.00 x 104.00mm	GG-2003-IN	<b>622-2003I</b>
4H7-12111-10-00	33.00 x 7.00 x 94.20mm	GG-2004-IN	<b>622-2004I</b>
4H7-12121-10-00	28.00 x 7.00 x 94.10mm	GG-2004-EX	<b>622-2004E</b>
583-12121-00-00	39.00 x 8.00 x 101.20mm	GG-2007-EX	<b>622-2007E</b>
1L9-12111-03-00	35.50 x 7.00 x 97.70mm	GG-2008-IN	<b>622-235I</b>
1L9-12121-02-00	30.00 x 7.00 x 96.90mm	GG-2008-EX	<b>622-235E</b>
3H5-12111-01-00	38.00 x 7.00 x 95.00mm	GG-2009-IN	<b>622-203I</b>
3H5-12121-00-00	32.00 x 7.00 x 93.50mm	GG-2009-EX	<b>622-203E</b>
11H-12111-00-00	38.00 x 7.00 x 95.00mm	GG-2010-IN	<b>622-236I</b>
2J2-12111-01-00	47.00 x 8.00 x 102.30mm	GG-2011-IN	<b>622-2011I</b>
5A8-12121-00-00	39.00 x 8.00 x 101.20mm	GG-2011-EX	<b>622-2011E</b>
5H0-12111-02-00	34.00 x 6.00 x 93.80mm	GG-2013-IN	<b>622-2013I</b>
5H0-12121-01-00	28.50 x 6.00 x 92.50mm	GG-2013-EX	<b>622-2013E</b>
4U8-12111-00-00	30.00 x 6.00 x 89.40mm	GG-2014-IN	<b>622-205I</b>
4U8-12121-00-00		GG-2014-EX	<b>622-205E</b>
5Y1-12111-00-00	30.00 x 6.00 x 89.40mm	GG-2017-IN	<b>622-208I</b>
1FK-12111-01-00	30.50 x 5.50 x 87.95mm	GG-2019-IN	<b>622-2019I</b>
1FK-12121-01-00	25.00 x 5.50 x 86.95mm	GG-2019-EX	<b>622-2019E</b>
1UY-12111-01-00	40.00 x 7.00 x 102.60mm	GG-2020-IN	<b>622-2020I</b>
1UY-12121-01-00	34.00 x 7.00 x 100.50mm	GG-2020-EX	<b>622-2020E</b>



## Heavy Duty Cylinder Head Studs

Heavy duty cylinder studs are necessary to prevent head gasket leakage in high compression and turbocharged engines. Stock studs are made from poor material that will stretch and allow gasket leakage. APE studs are made from heat treated chrome moly and have rolled threads for maximum strength. Sold in sets.

### Honda

CB750 SOHC	thru 78	CS750H	<b>875-140</b>
------------	---------	--------	----------------

### Kawasaki

KZ650/KZ750 2 valve fours		CS650K	<b>875-100</b>
KZ900/KZ1000/KZ1100		CS900K	<b>875-102</b>
ZX11/10/1000 Ninja***		CS1100K	<b>875-103</b>
ZX12		CS1200K	<b>875-104</b>

### Suzuki

GS1150		CS1150S	<b>875-122</b>
GSXR1100, 1127cc case (40mm starter hole)		CS1127GSX	<b>875-125</b>
GSXR1100W ***	93-98	CS1100GSXW	<b>875-126</b>
GSX1300R Hayabusa***		CS1300GSX	<b>875-127</b>
SV650	all	CS650S	<b>875-128</b>

### Yamaha

YZF-R1		CS1000R1	<b>875-163</b>
FJ1100/FJ1200		CS1100FJ	<b>875-164</b>

\*\*\*Must use Heavy Duty Cylinder Head Nuts

## Heavy Duty Cylinder Head Nuts

Super heat treated cylinder head nuts are a must for high output engines. Help prevent blown and leaking head gaskets caused by the threads in the soft stock nuts stretching. APE nuts are machined from alloy steel and fully heat treated for maximum strength. Nuts are .150" taller than stock to prevent the nut from bottoming out on the stud when the head has been milled. **Note:** Packed in complete engine sets.

Description	Order No.
10mm x 1.25 with 7/8 base dia.	<b>875-050</b>
Kawasaki KZ900/1000/1100	(APE#: CHN1000K)
Suzuki GS1100/1150	
GSXR750/1100 oil-cooled	
10mm x 1.25 with 3/4" base dia.	<b>875-051</b>
For use with any application requiring the smaller 3/4" base dia. Including <b>875-126</b> .	(APE#: CHN1100GSXW)
Special head nuts for use with <b>875-105</b> stud set	<b>875-053</b> (APE#: CHN1000TF)
Complete cylinder head nuts for <b>875-128</b> (10 pcs)	<b>875-055</b> (APE#: CHN10125-10)
Complete cylinder head nuts for <b>875-128</b> (8 pcs)	<b>875-054</b> (APE#: CHN10125-8)

## Three Bond Anaerobic Thread Locks

No matter what locking properties are required, one of Three Bond's thread lock products will get the job done. All of Three Bond's thread lock inhibit the development of rust, leaks, corrosion and are not affected by oils, chemicals, salt water, various gases or organic solvents.

Description	Three Bond Ref.	Order No.
Low Strength: Frequent Removal	TB1342 10ml	<b>800-120</b>
Medium Strength: Bearing & Stud	TB1333 10ml	<b>800-124</b>
High Temp: Extreme Temperature	TB1360 10ml	<b>800-128</b>





## APE High Performance Valve Springs

APE valve guides are made from special bronze alloy to resist wear and heat. Precision machined with the bores finished to size. They are designed to fit lower in the cylinder head to clear high lift cams, and use APE seals or factory OEM seals. Sold in sets for models listed.

## APE Titanium Valve Spring Retainers

APE valve spring retainers are machined from aircraft quality titanium bar stock in the APE plant on the latest state of the art computerized CNC machinery. Sold in sets for models listed.

Application	Use	Street	APE Spring. No	Spring Order. No	APE Retainer No.	Retainer Order No.
Honda 750 SOHC thru '78	street/race (TQ Midgets)	stock	VS750H	<b>875-330</b>	TVSRH750 (K model)	<b>875-390</b>
Kawasaki ZX7 '91-'95 kit type	Race				TVSRK750	<b>875-370</b>
Kawasaki ZX7 '96-'99			VS750K	<b>875-300</b>	TVSRK750-96	<b>875-371</b>
Kawasaki ZX9 '98-'00					TVSRK750-96	<b>875-371</b>
Kawasaki 650 thru 1100 2 valve	up to .460" lift	stock	VS900K	<b>875-301</b>	TVSRK1000 (sob)	<b>875-372</b>
Kawasaki 900 thru 1100 2 valve	.460" .510" lift		VSP500	<b>875-302</b>	TVSRK1000 (sob)	<b>875-372</b>
Kawasaki/Suzuki 2 Valve race	up to .540" lift		VSP520	<b>875-303</b>	TVSRK1000 (sob)	<b>875-372</b>
Kawasaki Ninja 900/1000	includes bases	stock	VS908KS	<b>875-305</b>		
Kawasaki ZX10/ZX11	includes bases	stock	VS1100K	<b>875-306</b>	TVSRK1100	<b>875-374</b>
Kawasaki ZX12	65 lbs seat pressure		VS1200K	<b>875-307</b>		
Suzuki GS1100/1150	street/race	stock	VS1100S	<b>875-320</b>	TVSRS1100	<b>875-378</b>
Suzuki GS1100/1150 pro race	60# @ 1.250", .460" lift		VS1100S-PRO	<b>875-321</b>	TVSRS750	<b>875-379</b>
Suzuki GSXR750 86-90	street/race	stock	VS750GSX	<b>875-322</b>	TVSRS750	<b>875-379</b>
Suzuki GSXR750 '91-'92 (shim style)	street/race				TVSRS750SH	<b>875-380</b>
	VSA204 shims req'd					
Suzuki GSXR750W '93-'95	street/race				TVSR1100SX	<b>875-381</b>
Suzuki GSXR750T '96-'99	street/race				TVSRS750-96	<b>875-382</b>
Suzuki GSXR1100 '93-'99	street/race	stock			TVSR1100GSX	<b>875-383</b>
Suzuki GSXR1300 Hayabusa	w/ stock springs				TVSR1300GSX	<b>875-384</b>
Suzuki GSXR1300 Hayabusa	race w/ APE springs		VS1300GSX	<b>875-325</b>	TVSR1300PRO	<b>875-385</b>
45 lbs of seat pressure with a .015" shim						
Suzuki GS550 thru 1000 2 valves	street/race	stock	VS1100S	<b>875-320</b>	TVSRK1000 (sob)	<b>875-373</b>
High seat pressure (65lbs) for high lift	cams or high boost turbo		VS1300GSX-2	<b>875-327</b>		
Yamaha FJ1100/1200	street/race/legends	stock	VS1100FJ	<b>875-341</b>	TVSR1100Y (sob)	<b>875-397</b>
Triumph Daytona 4-cylinder	street/race	stock	VS1200T	<b>875-350</b>		

## Motion Pro Valve Spring Compressor

Improved quick action design, used in same applications as Honda tool 07757-0010000 and Kowa tool AKS-215-1010 OEM tools. Accepts Motion Pro adapters (08-0248) as well as Honda OEM adapters 07GME-KT70200, 07JME-KY20100, and 07959-KM30101. For use in shim under bucket and small diameter valve spring keeper applications, both cup-type and ball-type tips are included. Adapter on compressor is double stepped. The inner step diameter is 17mm - Outer step diameter is 21mm.

Order No. **950-772**





## APE High Performance Valve Guides

APE valve guides are made from special bronze alloy to resist wear and heat. Precision machined with the bores finished to size. They are designed to fit lower in the cylinder head to clear high lift cams, and use APE seals or factory OEM seals. Sold in sets for models listed.

### Honda

Model	Year	APE No.	Order No.
750 SOHC	69-78	VGH750	<b>875-200</b>

### Kawasaki

KZ650 thru KZ1100	2-Valve	VGK900	<b>875-210</b>
ZX1000 Ninja ZX10	88-90	VGK1100K	<b>875-211</b>
ZX1100 Ninja ZX11	90-01	VGK1100K	<b>875-211</b>

### Suzuki

GS750/1100/1150	4 valve	VGS1100S	<b>875-220</b>
GSXR750/1100	thru 1992	VG750GSX	<b>875-221</b>
GSXR750W	93-95	VG1100GSX	<b>875-222</b>
GSXR1100W	93-98	VG1100GSX	<b>875-222</b>
GSX1300R Hayabusa	99-	VG1300GSX	<b>875-223</b>

### Yamaha

FJ1100	84-85	VGY110	<b>875-230</b>
FJ1200	86-93	VGY110	<b>875-230</b>

### Specials (oversize)

Application	Size	APE No.	Order No.
Kawasaki Z1/KZ1000/GPZ1100	004"	99101-4	<b>875-240</b>
Kawasaki Z1/KZ1000/GPZ1100	025"	99101-25	<b>875-241</b>
oversize repair guide (.502 dia)			
Suzuki GS guide with GSXR O.D		VGGSXR55	<b>875-247</b>



## APE Kawasaki Cam Chain Idler Adapter

This adapter allows the use of later model GPz 1100 or KZ1000J cylinder head on earlier model GPz 900/KZ1000 lower end. It maintains the roller style cam chain. This is the only modification necessary to install the big valve head on early motor. Use with OEM KZ sprockets or high performance aftermarket versions.

Description	APE No.	Order No.
Cam Chain Idler Adapter with Pin	CCIA	<b>875-450</b>



## Assembly Lube

Provides three-times greater film strength than conventional black Molybdenum Disulfide greases and will not clog oil filters. This product clings to all surfaces and is an excellent rust inhibitor, allowing the storage of parts for years. A thin film of protection is all that is required when mating parts. Sold in 4 oz. tub.

Order No. **900-840**

# Cam Chain Tensioners



875-405



875-789

## APE Manual Cam Chain Tensioners

**A Must for any kind of performance riding.** APE manual cam chain tensioners are CNC machined from billet alloy to exact tolerances for perfect fit. Designed to replace the automatic and hydraulic tensioners on high performance engines. The automatic adjusters can back out when the throttle is suddenly closed at high rpm. This allows the cams to go momentarily out of time and can result in bent valves and/or serious engine damage. Hydraulic tensioners have a tendency to put too much tension on the chain guide under high rpm/high oil pressure conditions resulting in premature wear. Both problems can be eliminated with the installation of the APE manual cam chain tensioner. No matter what the engine does, the cam chain tensioner will remain constant. Cam Chain Tensioners are sold each.

### Honda Street

#### Cam Chain Tensioner

Model	Year	APE No.	Order No.
CBR600F Hurricane	86-90	HT600	875-425
CBR600F2 Hurricane	91-94	HT600	875-425
CBR600F3 Hurricane	95-98	HT900	875-426
CBR600F4	99-00	HT900	875-426
CBR600F4I		HT900	875-426
CBR600RR	03-11	HT600RR	875-430
CB900F (919)	03-05	HT900	875-426
CBR900RR	93-99	HT900	875-426
CBR929RE	2001	HT929	875-427
CBR929RR	00-01	HT929	875-427
CBR954RR	02-03	HT929	875-427
CBR1000RR	04-06	HT600RR	875-430
VTR1000F Super Hawk (*qt2 required)	98-05	HT1000VTR	875-429*
CBR1100XX Blackbird	97-03	HT900	875-426

#### Cam Chain Tensioner Gasket

Cometic No.	Order No.
use OEM	_____
use OEM	_____
EC388	875-784
EC388	875-784
EC388	875-784
EC814	875-788
EC388	875-784
EC388	875-784
EC631	875-786
EC631	875-786
EC631	875-786
EC814	875-788
EC388	875-784*
EC388	875-784

### Honda Offroad

Model	Year	APE No.	Order No.	Cometic No.	Order No.
CRF150R	07-09, 12	HT250	875-431	EC377	875-783
CRF250R/CRF250X	04-12	HT250	875-431	EC377	875-783
CRF450R	04-08	HT450	875-432	EC377	875-783
CRF450R	09-12	HT250	875-431	EC377	875-783
TRX450R (ATV)	04-05	HT900	875-426	EC388	875-784
TRX450R (ATV)	06-09	HT450	875-432	_____	_____
XR650R		HT929	875-427	_____	_____

### Kawasaki Street

Model	Year	APE No.	Order No.	Cometic No.	Order No.
EX250	08-11	KT250	875-422	_____	_____
KTR250		KT900	875-419	_____	_____
EX500	All	KT1050	875-415	_____	_____
EN500 Vulcan 500	1995	KT1050	875-415	_____	_____
ZX600A Ninja 600R	85-87	KT1100	875-416	comes with o-ring	_____
ZX600C	88-97	KT1100	875-416	comes with o-ring	_____
ZX600F/G/J Ninja ZX-6R	95-12	KT750	875-417	_____	_____
ZX636B/C/D Ninja ZX-6R	03-06	KT750	875-417	_____	_____
ZX-6RR 636	00-04	KT750	875-417	_____	_____
GPz750	83-85	KT1000	875-418	_____	_____
VN750A Vulcan 750 (*qt2 required)	86-03	KT1100	875-416*	comes with o-ring	_____
ZX750H1/H2 Ninja ZX-7	89-90	KT1100	875-416	comes with o-ring	_____
ZX750J1/J2 Ninja ZX-7	91-92	KT750	875-417	_____	_____
ZX750K1/K2 Ninja ZX-7R	91-02	KT750	875-417	_____	_____
ZX750L1/L2/L3 Ninja ZX-7	93-95	KT750	875-417	_____	_____
ZX750M1/M2 Ninja ZX-7R	93-94	KT750	875-417	_____	_____
ZX750P1-P8 Ninja ZX-7R	96-03	KT750	875-417	_____	_____
KZ900A4/A5	76-77	KT1000	875-418	EC067	875-782
KZ900B1 LTD	1976	KT1000	875-418	EC067	875-782
Z1/A/B-900	73-75	KT1000	875-418	EC067	875-782
ZX900A Ninja 900R	84-86	KT1050	875-415	_____	_____
ZX900B Ninja ZX-9R	94-97	KT750	875-417	_____	_____
ZX900C/E/F Ninja ZX-9R	98-05	KT900	875-419	_____	_____
KZ1000A1/A2/A2A	77-78	KT1000	875-418	EC067	875-782
KZ1000A3/A3A/A4 MKII	79-80	KT1000	875-418	EC067	875-782
KZ1000B1/B2/B3/ B4 LTD	77-80	KT1000	875-418	EC067	875-782
KZ1000C1/C1A/C2/C3/C4 Police	78-81	KT1000	875-418	EC067	875-782
KZ1000D1 Z1R	1978	KT1000	875-418	EC067	875-782
KZ1000D3 Z1R	1980	KT1000	875-418	EC067	875-782
KZ1000E1/E2 Shaft ST	79-80	KT1000	875-418	EC067	875-782
KZ1000J	81-83	KT1100	875-416	comes with o-ring	_____



## Kawasaki Street

Cam Chain Tensioner		Cam Chain Tensioner Gasket			
Model	Year	APE No.	Order No.	Cometic No.	Order No.
KZ1000P Police	81-04	KT1100	875-416	comes with o-ring	_____
ZX1000A Ninja 1000R	86-87	KT1050	875-415	_____	_____
ZX1000B1/B2/B3 Ninja ZX-10	88-89	KT1050	875-415	_____	_____
ZX1000C1/C2/D6F Ninja ZX-10R	04-05	KTZX10	875-420	_____	_____
GPz1000	-84	KT1100	875-416	comes with o-ring	_____
ZX10	06-12	KTZX10-Pro			
ZR1100C3/C4 ZRX1100	99-00	KT1050	875-415	_____	_____
ZX1100C Ninja ZX-11	90-93	KT1050	875-415	_____	_____
ZX1100D1-D9 Ninja ZX-11	93-01	KT1050	875-415	_____	_____
ZX1100E1/E2/E3 GPz	95-96	KT1050	875-415	_____	_____
ZX1100F1 GPz (ABS)	1996	KT1050	875-415	_____	_____
ZR1200A ZRX1200	01-05	KT1050	875-415	_____	_____
ZX1200A/B Ninja ZX-12R	00-05	KT750	875-417	_____	_____
KZ1300		KT1050	875-415	_____	_____
ZX1400 Ninja ZX-14	06-11	KTZX14	875-421	_____	_____

## Kawasaki ATV & Offroad

KX250F		KT900	875-419	_____	_____
KLX400	2003	ST1300GX	875-405	EC377	875-783
KSF400 KFX ATV	04-06	ST1300GX	875-405	EC377	875-783

## Suzuki Street

GS500		ST650SV	875-408	EC377	875-783
GSXR600	93-96	ST1100GX	875-403	EC065	875-781
GSXR600	97-00	ST750GX	875-401	EC377	875-783
GSXR600	01-03	ST750Y2K	875-406	EC523	875-785
GSXR600	04-07	ST1000-3	875-407	EC745	875-787
SV650	99-04	ST650SV	875-408	EC377	875-783
GSX-R750 oil cooled	86-92	ST750	875-402	EC065	875-781
GSX-R750 water cooled	93-95	ST1100GX	875-403	EC065	875-781
GSX-R750 SRAD motors	96-99	ST750GX	875-401	EC377	875-783
GSX-R750	00-03	ST750Y2K	875-406	EC523	875-785
GSX-R750	04-08	ST1000-3	875-407	EC745	875-787
GSX-R1000K	01-02	ST750Y2K	875-406	EC523	875-785
GSX-R1000K	03-08	ST1000-3	875-407	EC745	875-787
GS1100/1150	all	ST1100	875-404	EC062	875-789
GSX-R1100 oil cooled	87-92	ST750	875-402	EC065	875-781
GSX-R1100 water cooled	93-98	ST1100GX	875-403	EC065	875-781
GSF1200 Bandit	97-05	ST750	875-402	EC065	875-781
GSX1300R Hayabusa	99-07	ST1300GX	875-405	EC377	875-783
GSX1300R Hayabusa	08-	ST1300-08PRO	875-409	_____	_____

## Suzuki ATV & Offroad

RM-Z250K		KT900	875-419	_____	_____
DR-Z400		ST1300GX	875-405	EC377	875-783
LT-Z400K ATV		ST1300GX	875-405	EC377	875-783

## Yamaha Street

FZR600W/R	89-99	YT1000	875-435	EC019	875-780
YZF-R6	99-05	YT1000	875-435	EC019	875-780
YZF-R6	06-12	YTR6	875-437	_____	_____
FZR750R	87-88	YT1000	875-435	EC019	875-780
YZF750R	94-98	YT1000	875-435	EC019	875-780
FZ1000 FZ1	01-03	YT1000	875-435	EC019	875-780
FZR1000	87-95	YT1000	875-435	EC019	875-780
YZF1000R	1997	YT1000	875-435	EC019	875-780
YZF-R1	98-03	YT1000	875-435	EC019	875-780
YZF-R1	04-06	YTR1	875-436	_____	_____
YZF-R1	09-11	YTR1-09	875-438	_____	_____
FJ1100	84-85	YT1000	875-435	EC019	875-780
FJ1200	86-93	YT1000	875-435	EC019	875-780

# Cam Chain Tensioners

## Yamaha ATV & Offroad

### Cam Chain Tensioner

Model	Year	APE No.	Order No.	Cometic No.	Order No.
TT-R125	00-05	YT1000	<a href="#">875-435</a>	EC019	<a href="#">875-780</a>
TT-R250	99-06	YT1000	<a href="#">875-435</a>	EC019	<a href="#">875-780</a>
WR250F	01-05	YT1000	<a href="#">875-435</a>	EC019	<a href="#">875-780</a>
YFB250 Beartracker	99-02	YT1000	<a href="#">875-435</a>	EC019	<a href="#">875-780</a>
YFM250 Timberwolf	92-01	YT1000	<a href="#">875-435</a>	EC019	<a href="#">875-780</a>
YZ250F	01-04	YT1000	<a href="#">875-435</a>	EC019	<a href="#">875-780</a>
YFM250 Timberwolf (ATV)	92-01	YT1000	<a href="#">875-435</a>	EC019	<a href="#">875-780</a>
WR250F	01-04	YT1000	<a href="#">875-435</a>	EC019	<a href="#">875-780</a>
WR400F	98-00	YT1000	<a href="#">875-435</a>	EC019	<a href="#">875-780</a>
YZ400F	98-99	YT1000	<a href="#">875-435</a>	EC019	<a href="#">875-780</a>
WR426F	01-02	YT1000	<a href="#">875-435</a>	EC019	<a href="#">875-780</a>
YZ426F	00-02	YT1000	<a href="#">875-435</a>	EC019	<a href="#">875-780</a>
WR450F	03-06	YT1000	<a href="#">875-435</a>	EC019	<a href="#">875-780</a>
WR450F	07-11	YT450	<a href="#">875-435</a>	EC019	<a href="#">875-780</a>
YZ450F	03-06	YT1000	<a href="#">875-435</a>	EC019	<a href="#">875-780</a>
YZ450F	06-09	YT450	<a href="#">875-435</a>	EC019	<a href="#">875-780</a>
YFZ450 (ATV)	04-05	YT1000	<a href="#">875-435</a>	EC019	<a href="#">875-780</a>

### Cam Chain Tensioner Gasket



### Gel Lube

Engine assembly is made easier, quicker, and cleaner with Valco's premier lubricant —GelLube™. GelLube sprays on thin and penetrates quickly—transforming into a heavy-duty, load-bearing, protective gel. GelLube does not drip, melt or shift when applied. GelLube bonds to metal surfaces and fills all small spaces and crevices on valve springs, cranks, cams, bearings and much more. Sold in 8 oz. can.

Order No. [800-565](#)



### LPC-3® Penetrating Oil

Super rust busting penetrating lubricant

- Multipurpose lubricant
  - Protects metal
  - Displaces moisture
- Sold in 11 fl. oz. aerosol can.

Order No. [899-191](#)

### Assembly Lube

Use on crankshafts, valve guides, cylinder walls, pistons, camshafts, etc. Synthetic and petroleum oil soluble.

Sold in 11 fl. oz. aerosol can.

Order No. [899-192](#)





950-191

## Cam Chain Tensioner Pushrod Kit

High performance kits contain 4 pieces: 1 push rod (5mm longer than stock), 2 heavy duty springs and tensioner block gasket. Improves cam chain function, prevents cam chain noise and extends cam chain life. **Made in Japan.** Available for the following Kawasaki models.

### Kawasaki

Model	Year	Order No.
<b>PRK-101</b>		<b>950-191</b>
<b>Model</b>	<b>Year</b>	
KZ1000J1/J2/J3	81-83	
KZ1000K1/K2 LTD	81-82	
KZ1000M1/M2 CSR	81-82	
KZ1000P1-P21 Police	82-02	
KZ1000R1/R2 Replica	82-83	
KZ1100A1/A2/A3 Shaft	81-83	
KZ1100B1/B2 GPz	81-82	
KZ1100D1/D2 Spectre	82-83	
KZ1100L1 LTD	1983	
ZN1100B1/B2 LTD Shaft	84-85	
ZX1100A1/A2 GPz	83-84	
<b>PRK-102</b>		<b>950-192</b>
<b>Model</b>	<b>Year</b>	
KZ650H1/H2/H3 CSR	81-83	
KZ700A1	1984	
ZN700A1/A2 LTD	84-85	
KZ750E1/E2/E3	80-82	
KZ750F1 LTD Shaft	1983	
KZ750H1/H2/H3/H4 LTD	80-83	
KZ750L3	1983	
KZ750N1/N2 Spectre	82-83	
KZ750R1 GPz	1982	
ZR750C1/C2/C3 Zephyr	91-93	
ZX750A1/A2/A3 GPz	83-85	
<b>PRK-103</b>		<b>950-193</b>
<b>Model</b>	<b>Year</b>	
KZ550A1/A2/A3/A4	80-83	
KZ550C1/C2/C3/C4 LTD	80-83	
KZ550D1 GPz	1981	
KZ550F1/F2 Spectre & LTD	83-84	
KZ550H1/H2 GPz	82-83	
KZ550M1 LTD	1983	
ZR550B1/B2/B3/B4 Zephyr	90-93	
ZX550A1/A2 GPz	84-85	



## White Lithium Grease

Multipurpose White Lithium Grease™ is a quality white grease (NLGI#1) specifically designed to protect engine parts. The exceptional consistency of this grease creates ease in application for all engine parts including valves, bearings, crankshafts, wheels and nut assemblies and all other areas where metal-metal contacts occur. Sold in 8 oz. tube.

Order No. **800-545**



## Synthetic CV-2 Grease

Red Line CV-2 Grease is designed to withstand the extreme temperatures and pressures which occur in high-performance wheel bearings and CV-joints. The excellent high-temperature stability, extreme-pressure protection, and water resistance enables it to out-perform even the best conventional or synthetic greases. Red Line CV-2 Grease can be used in a wide range of applications at temperatures ranging between -100° F to 500° F and provides good oxidation and corrosion resistance, low evaporation and oil separation, and has a minimum effect on rubber seals. Sold in 14 oz. tub.

Order No. **900-850**

# APE Cam Sprockets



## APE Adjustable Cam Sprocket Assemblies

*For models with Factory OEM Bolt on Sprockets*

APE manufactures the original "billet" adjustable cam sprockets. APE sprockets are necessary for precise cam timing to achieve maximum performance. APE sprockets are fully machined on the latest state of the art computerized equipment to precision tolerances and fully heat treated for extra long wear life. Its cam sprockets are used by most leading racers who demand top performance along with the safety of not chancing their expensive racing heads to reworked stock sprockets.

### Honda

Model	Year	APE No	Order No
CBR600F2/F3	91-98	ACS600H	<a href="#">875-510</a>
CBR600F4	99-	ACS600-4H	<a href="#">875-511</a>
CBR600RR	03-08	ACS600RR	<a href="#">875-515</a>
CBR900RR Firebird	93-99	ACS900H	<a href="#">875-512</a>
CBR929RR	00-01	ACS929H	<a href="#">875-513</a>
CBR954RR	02-03	ACS929H	<a href="#">875-513</a>
CBR1000RR	04-06	ACS929H	<a href="#">875-513</a>
CBR1100XX Blackbird	97-03	ACS1100H	<a href="#">875-514</a>

### Kawasaki

EX500	all	ACS500K	<a href="#">875-505</a>
ZX600		ACS600K	<a href="#">875-506</a>
ZX750F Ninja750R	87-90	ACS750K	<a href="#">875-507</a>
ZX750H Ninja ZX-7	89-90	ACS750K	<a href="#">875-507</a>
Z1/A/B-900	73-75	ACS900K	<a href="#">875-500</a>
KZ900A4/A5	76-77	ACS900K	<a href="#">875-500</a>
KZ900B1 LTD	1976	ACS900K	<a href="#">875-500</a>
KZ1000A1/A2	77-78	ACS900K	<a href="#">875-500</a>
KZ1000A3/A4 MKII	79-80	ACS1000K	<a href="#">875-501</a>
KZ1000B1/B2 LTD	77-78	ACS900K	<a href="#">875-500</a>
KZ1000B3/B4 LTD	79-80	ACS1000K	<a href="#">875-501</a>
KZ1000D1 Z1R	1978	ACS900K	<a href="#">875-500</a>
KZ1000D3 Z1R	1980	ACS1000K	<a href="#">875-501</a>
KZ1000E1/E2 Shaft	79-80	ACS1000K	<a href="#">875-501</a>
KZ1000J1/J2/J3	81-83	ACS1100K	<a href="#">875-503</a>
KZ1000K1/K2	81-82	ACS1100K	<a href="#">875-503</a>
KZ1000M1/M2	81-82	ACS1100K	<a href="#">875-503</a>
KZ1000P Police	82-05	ACS1100K	<a href="#">875-503</a>
KZ1000R1/R2 Replica	82-83	ACS1100K	<a href="#">875-503</a>
KZ1000 (w/32T)		ACS1000K	<a href="#">875-501</a>
Kaw with MK11	16T crank	ACS1100K-2B	<a href="#">875-504</a>
using stock GPZ1100	0 bolt cams.		
ZX1100A GPz	83-84	ACS1100K	<a href="#">875-503</a>
ZX1000B Ninja ZX-10	88-90	ACS1100ZX	<a href="#">875-509</a>
ZX1100C/D Ninja ZX-11	90-01	ACS1100ZX	<a href="#">875-509</a>
ZR1100 ZRX	99-00	ACS1100ZX	<a href="#">875-509</a>
ZR1200 ZRX	01-05	ACS1100ZX	<a href="#">875-509</a>
ZX1400 Ninja ZX-14	06-11	ACSZX14	<a href="#">875-541</a>

### Suzuki

Model	Year	APE No	Order No
GSXR600W	92-93	ACS750GSX	<a href="#">875-520</a>
GSXR750G/H	86-87	ACS750S	<a href="#">875-521</a>
GSXR750J/K	88-89	ACS1100GSX	<a href="#">875-522</a>
GSXR750L/M/N	90-92	ACS750S	<a href="#">875-521</a>
GSXR750W	93-95	ACS750GSX	<a href="#">875-520</a>
GS1100E	80-83	ACS1100S	<a href="#">875-524</a>
GS1150E	83-86	ACS1100S	<a href="#">875-524</a>
GSXR1100	86-92	ACS1100GSX	<a href="#">875-522</a>
GSXR1100W	93-98	ACS750GSX	<a href="#">875-520</a>
GSF1200 Bandit		ACS1200S	<a href="#">875-523</a>

### Yamaha

YZF-R6	99-05	ACS600	<a href="#">875-530</a>
YZF-R6	06-12	ACS Y06R6	
FZR750R	87-88	ACS750Y	<a href="#">875-531</a>
YZF750, OWO1		ACS1000Y	<a href="#">875-532</a>
FZR1000	87-88	ACS750Y	<a href="#">875-531</a>
FZR1000	89-95	ACS1000Y	<a href="#">875-532</a>
YZF-R1	99-03	ACS1000R1	<a href="#">875-533</a>
FJ1100	84-85	ACS1100FJ	<a href="#">875-534</a>
FJ1200	86-93	ACS1100FJ	<a href="#">875-534</a>





## APE Adjustable Cam Sprocket Assemblies

**For models with Factory Pressed on Sprockets**

APE adjustable cam sprocket assemblies allow the cam timing to be adjusted on models with factory pressed on sprockets. The CNC machined APE adapters are pressed on the cams in place of the stock sprocket. Then the slotted sprockets can be adjusted. All assemblies include two adapters, adjustable sprockets, and four bolts.

### Kawasaki

Application	Year	APE No.	Order No.
EX250 Ninja	08-11	ACS250KN	875-540
ZX600 Ninja ZX6		CSAKK600	875-550
ZX750 Ninja ZX7	91-00	CSAKK750	875-551
ZX900 Ninja ZX9R	94-97	CSAKK900	875-552
ZX900 Ninja ZX9R	98-later	CSAKK900-98	875-553
ZX1200 Ninja ZX12		CSAKK1200	875-544
ZX1400 Ninja ZX14		ACSZX14	875-541

### Suzuki

GSX-R600T	97-99	CSAKS750	875-560
GSX-R600K	01-09	CSAKS750-2	875-561
SV650	99-	CSAKS650	875-566
GSX-R750	98-99	CSAKS750	875-560
GSX-R750K	00-09	CSAKS750-2	875-561
GSX-R1000K	01-09	CSAKS750-2	875-561
GSX1300R Hayabusa	99-	CSZKS1300	875-565

## APE Cam Chain Conversion Kit

**For Suzuki GSX1300R Hayabusa**

Kit Includes heavy duty Tsubaki roller cam chain, crank/cam chain gear, and cam sprockets with adapters. **Please Note the following:** There will be some modifications on the cam chain guides that will need to be done. Not too complicated, and can be performed by any mechanic/technician. Instructions are included.

APE No. CCK1300GSX. Order No. 875-800



Triumph X75 Hurricane

Photo courtesy of Layla Guest / Brandon Castellanos



## Motion Pro Degree Wheel

Manufactured from .052" thick aluminum with a 6-3/4" outside diameter and a 6mm center hole. Black anodized finish with easy to read numbers. Check or set timing or cam timing. Use with 2 & 4-stroke engines. Sold each.

Order No. 950-442



## APE Positive Stop TDC Tools

The only accurate way to find TDC (top dead center). Available in the following sizes:

Description	Order No.
10mm TDC Tool	950-235
12mm TDC Tool	950-236
14mm TDC Tool	950-237

## Sudco Cam Chains

SUDCO cam chains are stock replacements for the models listed. Cam Chains available are endless. Master links are not available. **Made in Japan.** Available for the following models:



### Honda Street

Model	Year	Cam Chain Number x Links	Order No
CB750A Automatic	76-78	BF05M x 94L	<b>311-015</b>
CB750F Super Sport	76-78	BF05M x 94L	<b>311-015</b>
CB750K0/K1/K2/K3/K4/K5	69-75	BF05M x 94L	<b>311-015</b>
CB750K	76-78	BF05M x 94L	<b>311-015</b>

### Honda ATV

Model	Year	Cam Chain Number x Links	Order No
ATC90/K1/K2/K3	70-78	25H x 86L	<b>311-060</b>
ATC110	79-85	25H x 88L	<b>311-061</b>
ATC185	1980	25H x 100L	<b>311-063</b>
ATC185S	81-83	25H x 100L	<b>311-063</b>
ATC200	81-83	25H x 100L	<b>311-063</b>
ATC200E	82-83	25H x 100L	<b>311-063</b>
ATC200ES	1984	25H x 100L	<b>311-063</b>
ATC200M	84-85	25H x 100L	<b>311-063</b>
ATC200S	84-86	25H x 100L	<b>311-063</b>
ATC200X	83-87	25H x 100L	<b>311-063</b>
TRX200 Fourtrax	1984	25H x 100L	<b>311-063</b>
TRX200 Fourtrax	90-91	25H x 100L	<b>311-063</b>
TRX200D Fourtrax	91-97	25H x 100L	<b>311-063</b>
ATC250ES Big Red	85-87	82RH2015 x 110L	<b>311-103</b>
ATC250SX	85-87	82RH2015 x 110L	<b>311-103</b>
TRX250 Fourtrax 250	85-87	82RH2015 x 110L	<b>311-103</b>
TRX250X Fourtrax 250X	87-88	82RH2010 x 110L	<b>311-082</b>
TRX250X Fourtrax 250X	91-92	82RH2010 x 110L	<b>311-082</b>
TRX300 Fourtrax 300	88-00	82RH2010 x 110L	<b>311-082</b>
TRX300EX Fourtrax 300EX	93-00	82RH2010 x 110L	<b>311-082</b>
TRX300EX Sportrax 300EX	01-06	82RH2010 x 110L	<b>311-082</b>
TRX300FW Fourtrax 300 4x4	1988	82RH2010 x 110L	<b>311-082</b>
TRX300FW Fourtrax 300 4x4	90-00	82RH2010 x 110L	<b>311-082</b>
ATC350X	85-86	82RH2015 x 114L	<b>311-105</b>
TRX350 Fourtrax 4x4	86-87	82RH2015 x 114L	<b>311-105</b>
TRX350D Fourtrax Foreman	87-89	82RH2015 x 114L	<b>311-105</b>
TRX400EX Fourtrax 400EX	99-00	82RH2010 x 112L	<b>311-083</b>
TRX400EX Sportrax 400EX	01-06	82RH2010 x 112L	<b>311-083</b>

### Honda Dual Sport & Offroad

Model	Year	Cam Chain Number x Links	Order No
XL75	77-79	25H x 86L	<b>311-060</b>
XR75/K1/K2	73-75	25H x 86L	<b>311-060</b>
XR75	76-78	25H x 86L	<b>311-060</b>
CRF80F	04-07	25H x 88L	<b>311-061</b>
XL80S	80-85	25H x 88L	<b>311-061</b>
XR80	79-84	25H x 88L	<b>311-061</b>
XR80R	85-03	25H x 88L	<b>311-061</b>
CT90 Trail 90	66-68	25H x 86L	<b>311-060</b>
CT90K1-K5 Trail 90	69-75	25H x 86L	<b>311-060</b>
CT90 Trail 90	76-79	25H x 86L	<b>311-060</b>
SL90 Moto Sport	1969	25H x 86L	<b>311-060</b>
ST90K/K1/K2 Trail Sport 90	73-75	25H x 86L	<b>311-060</b>
SL100K/K1/K2/K3 Moto Sport	70-73	25H x 100L	<b>311-063</b>
XL100/K1	74-75	25H x 100L	<b>311-063</b>
XL100	76-78	25H x 98L	<b>311-062</b>
XL100S	79-85	25SH(DHA) x 102L	<b>311-070</b>
XR100	81-84	25SH(DHA) x 102L	<b>311-070</b>
XR100R	85-03	25SH(DHA) x 102L	<b>311-070</b>
CT125 Trail 125	1977	25H x 98L	<b>311-062</b>
SL125/K1/K2 Moto Sport	71-73	25H x 100L	<b>311-063</b>

### Honda Dual Sport & Offroad

Model	Year	Cam Chain Number x Links	Order No
TL125/K1/K2/S Trials	73-76	25H x 100L	<b>311-063</b>
XL125/K1	74-75	25H x 100L	<b>311-063</b>
XL125	76-78	25H x 98L	<b>311-062</b>
XL125S	79-85	25H x 98L	<b>311-062</b>
XL175	73-78	219H x 88L	<b>311-050</b>
XL185S	79-85	25H x 100L	<b>311-063</b>
XR185	1979	25H x 100L	<b>311-063</b>
TLR/TR200	86-87	25H x 100L	<b>311-063</b>
XL200R	83-84	25H x 100L	<b>311-063</b>
XR200	80-84	25H x 100L	<b>311-063</b>
XR200R	81-83	25H x 100L	<b>311-063</b>
XR200R	84-85	82RH2015 x 100L	<b>311-100</b>
XR200R	86-03	25H x 100L	<b>311-063</b>
TL250	75-76	219T x 94L	<b>311-051</b>
XL250K/K1/K2 Moto Sport	72-76	219T x 94L	<b>311-051</b>
XL250S	78-81	219T x 94L	<b>311-051</b>
XL250R	82-83	219T x 94L	<b>311-051</b>
XL250R	84-87	82RH2015 x 102L	<b>311-101</b>
XR250L	91-96	82RH2015 x 102L	<b>311-101</b>
XR250	79-80	219T x 94L	<b>311-051</b>
XR250R	81-82	219T x 94L	<b>311-051</b>
XR250R	84-95	82RH2015 x 102L	<b>311-101</b>
XR250R	96-04	82RH2010 x 102L	<b>311-080</b>
SL350/K1/K2 Moto Sport	69-73	219H x 94L	<b>311-051</b>
XL350R	84-85	82RH2015 x 108L	<b>311-102</b>
XR350R	83-85	82RH2015 x 108L	<b>311-102</b>
XR400R	96-04	82RH2010 x 112L	<b>311-083</b>
XL500S	79-81	82RH2015 x 120L	<b>311-107</b>
XL500R	1982	82RH2015 x 120L	<b>311-107</b>
XR500	79-80	82RH2015 x 120L	<b>311-107</b>
XR500R	81-82	82RH2015 x 120L	<b>311-107</b>
XR500R	83-84	82RH2015 x 118L	<b>311-106</b>
XL600R	83-87	82RH2015 x 118L	<b>311-106</b>
XL600V Transalp	89-90	82RH2010 x 118L	<b>311-084</b>
XR600R	85-87	82RH2015 x 118L	<b>311-106</b>
XR600R	89-00	82RH2010 x 118L	<b>311-084</b>
NX650	88-89	82RH2010 x 118L	<b>311-084</b>
XR650L	93-07	82RH2010 x 118L	<b>311-084</b>

### Kawasaki Street

Model	Year	Cam Chain Number x Links	Order No
KZ400A1/A2 Deluxe	77-78	BF05T x 88L	<b>313-088</b>
KZ400B1/B2	78-79	BF05T x 88L	<b>313-088</b>
KZ400C1	1978	BF05T x 88L	<b>313-088</b>
KZ400/D/D3/D4	74-77	BF05T x 88L	<b>313-088</b>
KZ400H1 LTD	1979	BF05T x 88L	<b>313-088</b>
KZ400S/S2/S3 Special	75-77	BF05T x 88L	<b>313-088</b>
KZ650B1/B2/B2A/B3	77-79	BF05T x 118L	<b>311-001</b>
KZ650C1/C2/C3 Custom	77-79	BF05T x 118L	<b>311-001</b>
KZ650D1/D1A/D2 SR	78-79	BF05T x 118L	<b>311-001</b>
KZ650E1 LTD	1980	BF05T x 118L	<b>311-001</b>
KZ650F1	1980	BF05T x 118L	<b>311-001</b>
KZ750B1/B2/B3/B4	76-79	BF05T x 130L	<b>313-130</b>
KZ750G1 LTD	1980	BF05T x 130L	<b>313-130</b>
ZX750J1/J2 Ninja ZX-7	91-92	BF05MU x 106L	<b>311-035</b>
ZX750K1/K2 Ninja ZX-7R	91-92	BF05MU x 106L	<b>311-035</b>
ZX750L1/L2/L3 Ninja ZX-7	93-95	BF05MU x 106L	<b>311-035</b>
ZX750M1/M2 Ninja ZX-7R	93-94	BF05MU x 106L	<b>311-035</b>

**Kawasaki Street**

Model	Year	Cam Chain Number x Links	Order No.
Z1/Z1A/Z1B-900	73-75	BS05MH x 122L	<b>311-027</b>
KZ900A4/A5	76-77	BS05MH x 122L	<b>311-027</b>
KZ900B1 LTD	1976	BS05MH x 122L	<b>311-027</b>
KZ1000A1/A2/A2A	77-78	BS05MH x 122L	<b>311-027</b>
KZ1000A3/A3A/A4 MKII	79-80	BS05MH x 124L	<b>311-028</b>
KZ1000B1/B2/B3 LTD	77-79	BS05MH x 122L	<b>311-027</b>
KZ1000B4 LTD	1980	BS05MH x 124L	<b>311-028</b>
KZ1000C1/C1A/C2 Police	78-79	BS05MH x 122L	<b>311-027</b>
KZ1000C3/C4 Police	80-81	BS05MH x 124L	<b>311-028</b>
KZ1000D1 Z1R	1978	BS05MH x 122L	<b>311-027</b>
KZ1000D3 Z1R	1980	BS05MH x 124L	<b>311-028</b>
KZ1000E1/E2 Shaft ST	79-80	BS05MH x 124L	<b>311-028</b>
KZ1000G1 LTD Classic	1980	BS05MH x 124L	<b>311-028</b>

**Kawasaki ATV**

KLF110A1/A2 Mojave 110	87-88	25H x 88L	<b>311-061</b>
KLF110B1 Mojave 110	1987	25H x 88L	<b>311-061</b>
KLT110A1/A2/A3	84-86	25H x 88L	<b>311-061</b>
KLT200A1/A2/A3/A4/A4A	81-83	BF05T x 90L	<b>311-002</b>
KLT200B1	1983	BF05T x 90L	<b>311-002</b>
KLT200C1/C2	83-84	BF05T x 90L	<b>311-002</b>
KLT250A1/A2	82-83	BF05T x 90L	<b>311-002</b>
KLT250C1/C2/C3 Prairie	83-85	BF05T x 90L	<b>311-002</b>
KLT250P1 Police	1984	BF05T x 90L	<b>311-002</b>
KSF250A1-A17 Mojave 250	87-03	82RH2010 x 158L	<b>311-088</b>
KSF250A18 KFX250 Mojave	2004	82RH2010 x 158L	<b>311-088</b>
KEF300A1-A6 Lakota 300	95-00	BF05T x 90L	<b>311-002</b>
KEF300B1/B2/B3 Sport	01-03	BF05T x 90L	<b>311-002</b>
KLF300A1/A2 Bayou	86-87	BF05T x 90L	<b>311-002</b>
KLF300B1-B17 Bayou 300	88-04	BF05T x 90L	<b>311-002</b>
KLF300C1-C16 Bayou 4x4	89-04	BF05T x 90L	<b>311-002</b>
KVF300A1-A4 Prairie 4x4	99-02	BF05T x 90L	<b>311-002</b>
KVF300B1-B4 Prairie 300	99-02	BF05T x 90L	<b>311-002</b>
KVF360A1-A3 Prairie 4x4	03-05	82RH2010 x 118L	<b>311-084</b>
KVF360A6F/A7F Prairie 4x4	06-07	82RH2010 x 118L	<b>311-084</b>
KVF360B1/B2/B3 360	03-05	82RH2010 x 118L	<b>311-084</b>
KVF360B6F/B7F Prairie 360	06-07	82RH2010 x 118L	<b>311-084</b>
KVF360C1 Prairie 360 4x4	2003	82RH2010 x 118L	<b>311-084</b>
Advantage Classic			
KVF360C2/C3 Prairie 360	04-05	82RH2010 x 118L	<b>311-084</b>
4x4 Hardwoods Green HD			
KVF360C6F/C7F Prairie 4x4	06-07	82RH2010 x 118L	<b>311-084</b>
Hardwoods Green HD			
KLF400B1-B7 Bayou 4x4	93-99	82RH2010 x 118L	<b>311-084</b>
KVF400A1/A2 Prairie 4x4	97-98	82RH2010 x 118L	<b>311-084</b>
KVF400B1 Prairie 400	1998	82RH2010 x 118L	<b>311-084</b>
KVF400C1-C4 Prairie 4x4	99-02	82RH2010 x 118L	<b>311-084</b>
KVF400D1-D4 Prairie 400	99-02	82RH2010 x 118L	<b>311-084</b>

**Kawasaki Dual Sport & Offroad**

KL250A1-A5	78-82	BF05T x 90L	<b>311-002</b>
KL250C1/C2	83-84	BF05T x 90L	<b>311-002</b>
KL250D2-D22 KLR250	85-05	82RH2010 x 158L	<b>311-088</b>
KLX250A1/A2 Offroad	79-80	BF05T x 90L	<b>311-002</b>

**Suzuki Street**

GS400B/XB/C/XC	77-78	BF05MU x 120L	<b>311-037</b>
GS425N/EN/LN	1979	BF05MU x 120L	<b>311-037</b>
GS450ET/EX/EZ/ED	80-83	BF05MU x 120L	<b>311-037</b>
GS450GAZ/GAD Automatic	82-83	BF05MU x 120L	<b>311-037</b>
GS450GAF Automatic	1985	BF05MU x 120L	<b>311-037</b>
GS450LT/LX/LZ/LD	80-83	BF05MU x 120L	<b>311-037</b>

**Suzuki Street**

Model	Year	Cam Chain Number x Links	Order No.
GS450LF/LG/LH/LJ	85-88	BF05MU x 120L	<b>311-037</b>
GS450ST/SX	80-81	BF05MU x 120L	<b>311-037</b>
GS450TX/TZ/TXZ/TXD	81-83	BF05MU x 120L	<b>311-037</b>
GS500EK/EL/EM/EN	89-92	BF05MU x 120L	<b>311-037</b>
GS500EP-EY/K1	93-01	BF05MU x 120L	<b>311-037</b>
GS550B/C/EC/N/EN/ET	77-80	BF05M x 116L	<b>311-016</b>
GS550LN/LT/LX/LZ	79-82	BF05M x 116L	<b>311-016</b>
GS550MZ Katana	1982	BF05M x 116L	<b>311-016</b>
GS550TX	1981	BF05M x 116L	<b>311-016</b>
GSX600FJ/FK/FL/FM Katana	88-91	BF05M x 116L	<b>311-016</b>
GSX600FN-FT Katana	92-96	BF05M x 116L	<b>311-016</b>
GSX-R600WN/WP	92-93	BF05MU x 110L	<b>311-036</b>
GS650EX/EZ	81-82	BF05M x 116L	<b>311-016</b>
GS650GX/GZ/GD	81-83	BF05MU x 120L	<b>311-037</b>
GS650GLX/GLZ/GLD	81-83	BF05MU x 120L	<b>311-037</b>
GS650MD Katana	1983	BF05MU x 120L	<b>311-037</b>
XN85D Turbo	1983	BF05MU x 120L	<b>311-037</b>
GS700EF/ESF	1985	BF05MU x 120L	<b>311-037</b>
GS750ET/EX/EZ	80-82	BF05MU x 122L	<b>311-038</b>
GS750ED/ESD	1983	BF05MU x 120L	<b>311-037</b>
GS750LN	1979	BF05MU x 120L	<b>311-037</b>
GS750LT/LX	80-81	BF05MU x 122L	<b>311-038</b>
GS750SD Katana	1983	BF05MU x 122L	<b>311-038</b>
GS750TZ/TD	82-83	BF05MU x 122L	<b>311-038</b>
GSX750FK-FV Katana	89-97	BF05M x 118L	<b>311-017</b>
GSX-R750G/H	86-87	BF05M x 116L	<b>311-016</b>
GSX-R750RG	1986	BF05M x 116L	<b>311-016</b>
GSX-R750JK	88-89	BF05M x 118L	<b>311-017</b>
GSX-R750L/M/N	90-92	BF05M x 116L	<b>311-016</b>
GSX-R750WP/WR/WS	93-95	BF05MU x 110L	<b>311-036</b>
GS850GN/GT/GX/GZ/GD	79-83	BF05MU x 120L	<b>311-037</b>
GS850GLT/GLX/GLZ/GLD	80-83	BF05MU x 120L	<b>311-037</b>
GS1000C/EC/N/EN/ET	78-80	BF05MU x 120L	<b>311-037</b>
GS1000GT/GLT/GX/GLX	80-81	BF05MU x 120L	<b>311-037</b>
GS1000LN	1979	BF05MU x 120L	<b>311-037</b>
GS1000SN/ST	79-80	BF05MU x 120L	<b>311-037</b>
GS1000LN	1979	BF05MU x 120L	<b>311-037</b>
GS1000SZ Katana	1982	BF05MU x 120L	<b>311-037</b>
GS1100ET/EX/EZ	80-82	BF05MU x 120L	<b>311-037</b>
GS1100ED/ESD	1983	BF05MU x 120L	<b>311-037</b>
GS1100GZ/GLZGD/GLD	82-83	BF05MU x 120L	<b>311-037</b>
GS1100GKZ/GK2/GKD/GKE	82-84	BF05MU x 120L	<b>311-037</b>
GS1100LT	1980	BF05MU x 120L	<b>311-037</b>
GS1100SD Katana	1983	BF05MU x 120L	<b>311-037</b>
GSX1100FJ/K/L/M/N/P Katana	88-93	BF05MU x 122L	<b>311-038</b>
GSX-R1100G/H/J/K/L/M/N	86-92	BF05MU x 122L	<b>311-038</b>
GSX-R1100W	93-98	BF05MU x 110L	<b>311-036</b>
GS1150ES3/ESE/EF/ESF	83-84	BF05MU x 120L	<b>311-037</b>
GS1150EF2/EG/ESG	85-86	BF05MU x 120L	<b>311-037</b>

**Suzuki ATV**

ALT/LT125D/E/F/G/H	83-87	25H x 98L	<b>311-062</b>
LT160EK/EL/EM/EN	89-92	25H x 98L	<b>311-062</b>
LT-F160M-K1	91-01	25H x 98L	<b>311-062</b>
ALT185F/LT185E/F/G/H	84-87	25H x 98L	<b>311-062</b>
LT230EH/J/K/L/M/N/P	87-93	25SH(DHA) x 104L	<b>311-071</b>
LT230GEF/EG/EG Quad	85-86	25SH(DHA) x 104L	<b>311-071</b>
LT230SF/SG/SH/SJ Quad	85-88	25SH(DHA) x 104L	<b>311-071</b>
LT-F230G/H Quadrunner	86-87	25SH(DHA) x 104L	<b>311-071</b>
LT250EFF/EFQ Quad	85-86	82RH2015 x 112L	<b>311-104</b>
LT250SK/SL Quadrunner	89-90	25H x 104L	<b>311-064</b>
LT-F250J/K/L/M/N/P	88-93	25H x 104L	<b>311-064</b>
LT-F250R/S/T/V/W	94-98	25H x 104L	<b>311-064</b>
LT-F250FX/FY/FK1/FK2	99-02	25H x 104L	<b>311-064</b>

# Cam Chains

## Suzuki ATV

Model	Year	Cam Chain Number x Links	Order No.
LT-F250 FK2-FK7	02-07	25H x 104L	<b>311-064</b>
LT300EH/EJ/EK Quadrunner	87-89	82RH2015 x 118L	<b>311-106</b>
LT-F300FX-FK3 King Quad	99-03	82RH2010 x 108L	<b>311-081</b>
LT-4WDH/J/K/L/M	87-91	25H x 104L	<b>311-064</b>
LT-4WDN/P/R/S/T	92-97	25H x 104L	<b>311-064</b>
LT-F4WDV/W King Quad	97-98	25H x 104L	<b>311-064</b>
LT-F4WDXM/N/P King Quad	91-93	82RH2010 x 108L	<b>311-081</b>
LT-F4WDXR/S/T King Quad	94-96	82RH2010 x 108L	<b>311-081</b>
LT-F4WDXV/W King Quad	97-98	82RH2010 x 108L	<b>311-081</b>
LT-A400FK2/FK3 Eiger 4WD	02-03	82RH2010 x 108L	<b>311-081</b>
LT-A400K2/K3 Eiger	02-03	82RH2010 x 108L	<b>311-081</b>
LT-F400 FK2-FK7 Eiger 4WD	02-07	82RH2010 x 108L	<b>311-081</b>
LT-F400K2-K7 Eiger	02-07	82RH2010 x 108L	<b>311-081</b>

## Suzuki Dual Sport & Offroad

DR100D-L	83-90	25H x 98L	<b>311-062</b>
SP100D Dual Sport	1983	25H x 98L	<b>311-062</b>
DR125Z/D/E	82-84	25H x 98L	<b>311-062</b>
DR125G/H/J	86-88	25H x 98L	<b>311-062</b>
DR125SER/SES/SET Dual	94-96	25H x 98L	<b>311-062</b>
SP125Z/D Dual Sport	82-83	25H x 98L	<b>311-062</b>
SP125G/H/J Dual Sport	86-88	25H x 98L	<b>311-062</b>
DR200G/H/J	86-88	25SH(DHA) x 104L	<b>311-071</b>
DR200SET-SEK7 Dual Sport	96-07	25SH(DHA) x 104L	<b>311-071</b>
SP200G/H/J Dual Sport	86-88	25SH(DHA) x 104L	<b>311-071</b>
DR250Z/D Offroad	82-83	82RH2015 x 112L	<b>311-104</b>
DR250F Offroad	1985	82RH2015 x 112L	<b>311-104</b>
DR250L/M/N/P Offroad	90-93	82RH2010 x 108L	<b>311-081</b>
DR250SL-SES Dual Sport	90-95	82RH2010 x 108L	<b>311-081</b>
SP250Z/D Dual Sport	82-83	82RH2015 x 112L	<b>311-104</b>
SP250F Dual Sport	1985	82RH2015 x 112L	<b>311-104</b>
DR350L-X Offroad	90-99	82RH2010 x 108L	<b>311-081</b>
DR350SL-SEX Dual Sport	90-99	82RH2010 x 108L	<b>311-081</b>
DR500X/Z/D Offroad	81-83	82RH2015 x 124L	<b>311-081</b>
SP500X/Z/D Dual Sport	81-83	82RH2015 x 124L	<b>311-108</b>
SP600F Dual Sport	1985	82RH2015 x 124L	<b>311-108</b>
DR650SL-SES Dual Sport	90-95	82RH2015 x 124L	<b>311-108</b>

## Yamaha Street

FZR400U/SUCM/SWC/A/SAC	88-90	BF04MA x 112L	<b>311-010</b>
FZR600W/WC/AC	89-90	BF04MA x 118L	<b>311-011</b>
FZR600RA/RAC-RL/RLC	90-99	BF04MA x 118L	<b>311-011</b>
FZ700T/TC	1987	BS05MH x 110L	<b>311-026</b>
FZX700S/SC/T/TC Fazer	86-87	BS05MH x 110L	<b>311-026</b>
FZ750N/S/SC	85-86	BS05MH x 110L	<b>311-026</b>
FZR750RT/RU	87-88	BS05MH x 110L	<b>311-026</b>
FZR1000T/TC/U/UC	87-88	BS05MH x 110L	<b>311-026</b>
FZR1000W/WC-G/GC	89-95	BS05MH x 108	<b>311-025</b>
XJ1100J Maxim	1982	BF05M x 128L	<b>311-018</b>
XS1100E/F/G/H	78-81	BF05M x 128L	<b>311-018</b>
XS1100LG/LH Midnight Special	80-81	BF05M x 128L	<b>311-018</b>
XS1100SF/SG/SH Special	79-81	BF05M x 128L	<b>311-018</b>
VMX12N/NC-T/TC V-Max	86-05	BF05M x 118L	<b>311-017</b>
VMX12V/VC V-Max	2006	BF05M x 118L	<b>311-017</b>

## Yamaha ATV

Model	Year	Cam Chain Number x Links	Order No.
YFM200N Moto 4	1985	25H x 104L	<b>311-064</b>
YFM200DXS-DXW Moto 4	86-89	25H x 104L	<b>311-064</b>
YTM200EK/EL Tri-Moto	83-84	25H x 104L	<b>311-064</b>
YTM200ERN Tri-Moto	1985	25H x 104L	<b>311-064</b>
YTM200K/L/N Tri-Moto	83-85	25H x 104L	<b>311-064</b>
YFM225S/T/U Moto 4	86-88	25H x 104L	<b>311-064</b>
YTM225DXK/DXL/DXN	83-85	25H x 104L	<b>311-064</b>
YTM225DRN/DRS Tri-Moto	85-86	25H x 104L	<b>311-064</b>
YFU1W (230cc) Pro Hauler	1989	25H x 104L	<b>311-064</b>
YFU1TW (230cc) Pro Hauler	1989	25H x 104L	<b>311-064</b>
YFB250D-H Timberwolf	92-96	25H x 104L	<b>311-064</b>
YFB250UH-UK Timberwolf	96-98	25H x 104L	<b>311-064</b>
YFB250FWF-FWM Timberwolf	94-00	25H x 104L	<b>311-064</b>
YFM250W/A/B Moto-4	89-91	25H x 104L	<b>311-064</b>
YFM250XL/XLC	1999	25H x 104L	<b>311-064</b>
YFM250M/MC Beartracker	2000	25H x 104L	<b>311-064</b>
YFM250BV	2006	25H x 104L	<b>311-064</b>
YFM350ERT-ERG Moto 4	87-95	BF05M x 90L	<b>311-013</b>
YFM350FWT-FWJ Big Bear	87-97	BF05M x 90L	<b>311-013</b>
YFM350FWB Big Bear	97-99	BF05M x 90L	<b>311-013</b>
YFM350UH-UL Big Bear	96-99	BF05M x 90L	<b>311-013</b>
YFM350FX Wolverine	95-01	BF05M x 90L	<b>311-013</b>
YFM350XT-XS/XSC Warrior	87-04	BF05M x 90L	<b>311-013</b>
YFM350S/RT/RV/RW Raptor	04-07	BF05M x 90L	<b>311-013</b>
YFM350RSET Raptor 350 SE	2005	BF05M x 90L	<b>311-013</b>
YFM350RSEV Raptor 350 SE	2006	BF05M x 90L	<b>311-013</b>
YFP350U Terraport	1988	BF05M x 90L	<b>311-013</b>
YFM600FW Grizzly	98-00	82RH2015 x 126L	<b>311-109</b>
YFM600HM/HMC	2000	82RH2015 x 126L	<b>311-109</b>
YFM660RP/RPB Raptor	2001	82RH2015 x 126L	<b>311-109</b>

## Yamaha Dual Sport & Offroad

XT125J/K/KC Dual Sport	82-83	25H x 104L	<b>311-064</b>
BW200N/S/ES/ET/EU	85-88	25H x 104L	<b>311-064</b>
TW200T/TC-R/RC Trailway	87-03	25H x 104L	<b>311-064</b>
XT200J/K/KC Dual Sport	82-83	25H x 104L	<b>311-064</b>
TT225S/T	86-87	25H x 104L	<b>311-064</b>
TT225L/LC/RM/RMC	99-00	25H x 104L	<b>311-064</b>
TT-R225N/NC/P/PC/R/RC	01-03	25H x 104L	<b>311-064</b>
XT225 Serrow	92-07	25H x 104L	<b>311-064</b>
TT250G/H/J Offroad	80-82	BF05M x 90L	<b>311-013</b>
XT250G/H/J/K/KC Dual Sport	80-83	BF05M x 90L	<b>311-013</b>
XT250L/LC Dual Sport	1984	82RH2015 x 136L	<b>311-110</b>
BW350 T/U	87-88	BF05M x 92L	<b>311-014</b>
TT350S/T Offroad	86-87	82RH2015 x 136L	<b>311-110</b>
XT350N/NC-M/MC Dual	85-00	82RH2015 x 136L	<b>311-110</b>
TT500C/D/E/F/G/H Offroad	76-81	BF05M x 106L	<b>311-019</b>
XT500C/D/E/F/G/H Dual	76-81	BF05M x 106L	<b>311-019</b>
XT550J/K Dual Sport	82-83	82RH2015 x 126L	<b>311-109</b>
TT600K/L/N/S Offroad	83-86	82RH2015 x 126L	<b>311-109</b>
XT600L/LC-EG/EGC Dual	84-95	82RH2015 x 126L	<b>311-109</b>





## Alternator Block Off Cover

APE alternator block off covers allow the removal of the alternator on race only bikes. Their unique design makes them a simple bolt on replacement for the alternator, which can be re-installed if desired. Complete with o-ring and mounting bolts.

### Kawasaki

ZX7 '91-'96 ABP-K750 [875-607](#)

### Suzuki

GSXR750/1100 oil-cooled thru '92 ABP-S1100 [875-605\\*](#)

### Yamaha

FZR750/1000/FJ1100/1200 ABP-Y1100 [875-606](#)

\*This model has the top mounting ear eliminated as most racers remove the top flange from the cases to facilitate the installation of larger carbs.

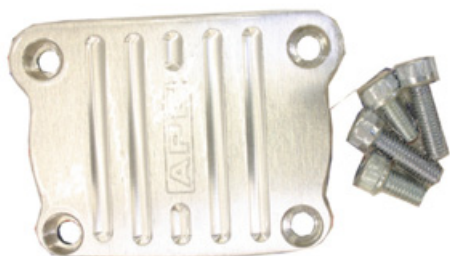

## Kawasaki Kick Start Block Off Cover

Much weight can be saved by removing the kick start Assy. from Kawasaki drag bikes. APE makes it simple for the racer to remove the entire kick start mechanism from his Kawasaki. This billet cover bolts on and prevents any leaks. For Kawasaki KZ900/1000 thru 1980.

APE No. 99211 Order No. [875-630](#)



## Kawasaki Low Profile Oil Filter Cover

The original oil filter cover for lowered Kawasaki race bikes. Provides the maximum clearance under the bike. Kit comes complete with plate, special filter bolt, low profile drain plug, and allen wrench. The 2" minimum ground clearance rule is being strictly enforced by all of the drag racing organizations.

Description	APE No.	Order No
Z1/KZ900/KZ1000 thru 1980	OFC1000K	<a href="#">875-620</a>
Drain Plug only for 875-620	DPK900	<a href="#">875-622</a>



## Heavy Duty Main Bearing Studs

Heat treated chrome moly main bearing studs (case studs) are necessary to prevent the cases from moving around under power in high output engines. These high strength studs help to prevent crankshaft damage. Made from the same special chrome moly that are used in APE cylinder studs. All threads are rolled after heat treat for maximum strength.

### Kawasaki

Model	APE No.	Order No.
KZ900/1000/1100	MBS1000K	<a href="#">875-190</a>

### Suzuki

GS1100	MBS1100S	<a href="#">875-191</a>
GSX-R1100 thru 1992	MBS1100GSX	<a href="#">875-192</a>
GSX1300R Hayabusa	MBS1300GSX	<a href="#">875-193</a>



## Kawasaki Main Bearing Support Cap

Helps prevent crankshaft flex and resulting broken cranks. This is necessary on all Kawasaki's that make serious horsepower. All KZ900/1000 thru 1978.

APE No. 99285 Order No. [875-198](#)



## Kawasaki Low Profile Breather Cover

At last a low profile cover to replace the tall OEM breather cover. Allows plenty of room for large carbs, turbochargers, etc. CNC machined from billet stock. Uses factory o-ring. Plain for applications where motor is vented from starter hole. Or drilled and tapped for fitting and breather filter. Sold each.

Description	APE No.	Order No.
Plain	KBC1000K	<a href="#">875-640</a>
Tapped	KBC1000D	<a href="#">875-641</a>

# Piston Kits



## JE Racing Piston Kits

Sudco International is pleased to offer J.E. Pistons to the motorcycle performance industry. J.E. Pistons have gained an excellent reputation for top quality products. Consider these outstanding features:

- Made in U.S.A. from premium certified aerospace materials
- Ultra light weight, fully C.N.C. machined from dedicated forging
- Proprietary wrist pin designs for the maximum strength and light weight
- O.E.M. style rings for long term cylinder seal
- NASCAR proven durability
- All piston kits include pistons, rings, wrist pins, & pin clips
- Most big bore kits and gaskets for import motorcycles are in stock
- Sleeve type big bore piston kits are available by special order

### J.E. Piston Kits/Cometic Gaskets

Notes: \* = 1197cc & up, requires re-sleeving and top case boring N = Requires cylinder boring and nikasil process  
 \*\* = 1327cc & up, big block cylinders recommended

#### Ducati

Model	Year	Displ.	Bore	Over Size	Comp. Ratio	Weight	JE Kit #	Piston Kit #	Head Gasket #	Base Gasket
916 4V 21mm Pin	94-96	955cc	96mm	+2mm	12.0:1	325g	131366	625-900	_____	_____
900SS	91-02	900cc	92mm	STD	11.5:1	361g	157597	625-905	_____	_____
900SS	91-02	944cc	94mm	+2mm	11.5:1	383g	157598	625-906	_____	_____

#### Harley Davidson®

883/1200 Sportster	85-08	1200cc	3.498"	STD	9.5:1	332g	129856	625-910	_____	_____
883/1200 Sportster	85-08	1205cc	3.503"	+ .005"	10.5:1	350g	132986	625-915	_____	_____
883/1200 Sportster	85-08	1208cc	3.508"	+ .010"	10.5:1	350g	132987	625-916	_____	_____
883/1200 Sportster	85-08	1214cc	3.518"	+ .020"	10.5:1	354g	132988	625-917	_____	_____
EVO Bathtub Big Bore	85-99	1340cc	3.498"	STD	10.5:1	392g	134092	625-934	_____	_____
		1342cc	3.503"	+ .005"	8.5:1	350g	124962	625-920	_____	_____
		1342cc	3.503"	+ .005"	9.5:1	370g	124846	625-924	_____	_____
		1342cc	3.503"	+ .005"	10.0:1	385g	133732	625-929	_____	_____
		1342cc	3.503"	+ .010"	10.5:1	394g	134093	625-935	_____	_____
		1345cc	3.508"	+ .010"	8.5:1	350g	126943	625-921	_____	_____
		1345cc	3.508"	+ .010"	9.5:1	372g	124847	625-925	_____	_____
		1345cc	3.508"	+ .010"	10.0:1	385g	133733	625-930	_____	_____
		1345cc	3.508"	+ .010"	10.5:1	394g	134094	625-936	_____	_____
		1353cc	3.518"	+ .020"	9.5:1	374g	124848	625-926	_____	_____
		1353cc	3.518"	+ .020"	10.0:1	391g	133734	625-931	_____	_____
		1353cc	3.518"	+ .020"	10.5:1	400g	134095	625-937	_____	_____
		1361cc	3.528"	+ .030"	10.0:1	395g	133735	625-932	_____	_____
Shovelhead 89"	78-84	1438cc	3.625"	STD	10.5:1	456g	138673	625-940	_____	_____
Buell S1, Thunderbolt, White Lighting-S3/S3T		1200cc	3.498"	STD	10.0:1	333g	161949	625-965	_____	_____
Buell S1, Thunderbolt, White Lighting-S3/S3T		1207cc	3.508"	+ .010"	10.0:1	337g	161950	625-966	_____	_____
Twin Cam Big Bore	99-06	1546cc*	3.875"	STD	10.25:1	412g	161936	625-943	_____	_____
Twin Cam Big Bore	99-06	1554cc*	3.885"	+ .010"	10.25:1	415g	161935	625-944	_____	_____

#### Honda

XR250L Dual Sport	91-96	270cc	76mm	+3mm	10.5:1	208g	127918	625-100	607-001 (kit)	kit only
XR250L Dual Sport	91-96	277cc	77mm	+4mm	10.5:1	215g	131243	625-101	607-001 (kit)	kit only
XR250R	86-04	270cc	76mm	+3mm	10.5:1	208g	127918	625-100	607-001 (kit)	kit only
XR250R	86-04	277cc	77mm	+4mm	10.5:1	215g	131243	625-101	607-001 (kit)	kit only
TRX400EX ATV	99-06	397cc	85mm	STD	10.5:1	263g	132697	625-110	_____	_____
TRX400EX ATV	99-06	406cc	86mm	+1mm	10.6:1	287g	132699	625-112	_____	_____
TRX400EX ATV	99-06	415cc	87mm	+2mm	10.8:1	291g	133889	625-113	_____	_____
XR400R	96-04	397cc	85mm	STD	10.5:1	263g	132697	625-110	_____	_____
XR400R	96-04	406cc	86mm	+1mm	10.6:1	287g	132699	625-112	_____	_____
XR400R	96-04	415cc	87mm	+2mm	10.8:1	291g	133889	625-113	_____	_____
TRX450R ATV	04-05	449cc	94mm	STD	11.5:1	292g	221771	625-181	_____	_____
TRX450R ATV	04-05	449cc	94mm	STD	13.0:1	299g	221767	625-180	_____	_____
CBR600F2/F3 Mini Sprint	91-98	618cc	66mm	+1mm	13.5:1	140g	163620	625-155	_____	_____
CBR600F2/F3 Hurricane	91-98	618cc	66mm	+1mm	13.5:1	140g	144537	625-150	_____	_____
CBR600F2/F3 Hurricane	91-98	637cc	67mm	+2mm	13.5:1	148g	144538	625-151	_____	_____

## Honda

Model	Year	Displ.	Bore	Over Size	Comp. Ratio	Weight	JE Kit #	Piston Kit #	Head Gasket #	Base Gasket
XR600R	85-00	629cc	100mm	+3mm	10.5:1	386g	128995	625-120	607-005 (kit)	kit only
XR600R	85-00	640cc	101mm	+4mm	10.6:1	397g	128996	625-121	607-007 (kit)	kit only
XR600R	85-00	654cc	102mm	+5mm	10.8:1	395g	128998	625-123	607-007 (kit)	kit only
XR650R Offroad	00-05	649cc	100mm	STD	11.0:1	387g	190862	625-134	_____	_____
XR650L Dual Sport	93-06	644cc	100mm	STD	10.5:1	399g	130682	625-132	607-003 (kit)	kit only
XR650L Dual Sport	93-06	650cc	101mm	+1mm	10.5:1	412g	138978	625-130	_____	_____
XR650L Dual Sport	93-06	657cc	102mm	+2mm	10.5:1	406g	139550	625-131	_____	_____
NT650 Hawk GT	88-91	696cc	82mm	+3mm	11.0:1	276g	157589	625-171	_____	_____
CB750 (SOHC)	69-78	836cc	65mm	+3mm	10.5:1	151g	144539	625-160	_____	_____
CBR900RR	92-95	945cc	72mm	+2mm	12.0:1	175g	138979	625-165	_____	_____
CBR900RR	96-98	997cc	74mm	+3mm	12.0:1	184g	157587	625-166	_____	_____
RVT1000R (RC51)	00-01	999cc	100mm	STD	11.5:1	367g	184333	625-178	_____	_____
VTR1000F Super Hawk	97-01	996cc	98mm	STD	11.5:1	385g	149139	625-174	* Uses O.E.M rings	_____
CBR1100XX Blackbird	97-01	1195cc	81mm	+2mm	11.5:1	223g	153766	625-176	_____	_____

## Kawasaki

KSF400A KFX400 ATV	03-06	398cc	90mm	STD	12.0:1	286g	180297	625-520	_____	_____
KSF400A KFX400 ATV	03-06	434cc	94mm	+4mm	12.0:1	280g	183051	625-521	_____	_____
KLX400	2003	398cc	90mm	STD	12.0:1	286g	180297	625-520	_____	_____
KLX400	2003	434cc	94mm	+4mm	12.0:1	280g	183051	625-521	_____	_____
KLX650	93-96	650cc	100mm	STD	10.5:1	378g	129225	625-620	_____	_____
ZX750 Ninja ZX-7R	91-95	791cc	73mm	+2mm	12.0:1	194g	153765	625-615	_____	_____
ZX750P Ninja ZX-7R	96-03	770cc	74mm	+1mm	13.0:1	188g	149299	625-640	_____	_____
ZX750N Ninja ZX-7RR	1996	770cc	74mm	+1mm	13.0:1	188g	149299	625-640	_____	_____
ZX900B Ninja ZX-9R (Flat Top)	94-97	924cc	74mm	+1mm	13.0:1	188g	156026	625-645	_____	_____
ZX900C/E Ninja ZX-9R	98-01	936cc	76.5mm	+1.5mm	12.0:1	208g	157592	625-625	_____	_____
KZ900/1000 (early KZ)	76-80	1015cc	70mm	STD	10.25:1	193g	137712	625-600	607-110	607-200
KZ900/1000 (early KZ)	76-80	1075cc	72mm	+2mm	8.5:1	195g	125083	625-601	607-111	607-200
KZ900/1000 (early KZ)	76-80	1075cc	72mm	+2mm	10.25:1	201g	125473	625-602	607-111	607-200
KZ900/1000 (early KZ)	76-80	1200cc	76mm*	+6mm	10.25:1	220g	132493	625-603	607-112	607-200
ZX1100C/D Ninja ZX-11	90-00	1109cc	78mm	+2mm	12.0:1	212g	133996	625-610	607-135	607-240
ZX1100E GPz1100	95-96	1109cc	78mm	+2mm	12.0:1	212g	133996	625-610	_____	_____
ZR1100C ZRX1100	99-00	1109cc	78mm	+2mm	12.0:1	212g	133996	625-610	_____	_____
ZX1200 Ninja ZX12R	00-05	1198cc	83mm	STD	13.0:1	236g	222109	625-631	_____	_____
ZX1200 Ninja ZX12R	00-05	1287cc	86mm	+3mm	13.0:1	264g	192315	625-630	_____	_____

## Royal Enfield

Enfield 500				STD	9.5:1		182560	625-950	_____	_____
-------------	--	--	--	-----	-------	--	--------	---------	-------	-------

## Suzuki

DR350R/S	90-99	441cc	89mm	+10mm	10.5:1	275g	130928	625-400	607-009 (kit)	kit only
DR350R/S	90-99	442cc	89.25mm	+10.25mm	10.5:1	277g	131242	625-401	607-009 (kit)	kit only
DR350R/S	90-99	443cc	89.50mm	+10.5mm	10.5:1	283g	131241	625-402	607-009 (kit)	kit only
DR-Z400	00-06	398cc	90mm	STD	12.0:1	286g	180297	625-520	_____	_____
DR-Z400	00-06	434cc	94mm	+4mm	12.0:1	280g	183051	625-521	_____	_____
LTZ400 ATV	03-07	398cc	90mm	STD	12.0:1	286g	180297	625-520	_____	_____
LTZ400 ATV	03-07	434cc	94mm	+4mm	12.0:1	280g	183051	625-521	_____	_____
DR650	90-98	650cc	100mm	STD	10.5:1	375g	136633	625-406	_____	_____
SV650	99-06	677cc	83mm	+2mm	13.0:1	239g	169253	625-510	_____	_____
GSXR750	00-03	791cc	74mm	+2mm	12.5:1	_____	222104	Custom	_____	_____
GSXR750	00-03	812cc	75mm	+3mm	12.5:1	_____	222103	Custom	_____	_____
GSXR750W	93-95	907cc	77mm**	+7mm	13.0:1	196g	138983	625-420	607-150	_____
GSXR1000	01-04	1070cc	76mm	+3mm	13.5:1	180g	192322	625-425	_____	_____
GS1100 Pro-Mod	81-83	1394cc	82mm		12.0:1	287g	144259	625-478	_____	_____
GS1100 (Drag Race)	81-83	1500cc	85mm	+13mm	12.5:1	294g	190680	625-480	_____	_____
GS1100 (Dome)	81-83	1134cc	74mm	+2mm	13.5:1	214g	130298	625-470	607-100	607-203
GS1100 (Dome)	81-83	1197cc	76mm*	+4mm	13.5:1	226g	128820	625-471	607-101	607-204
GS1100 (Dome)	81-83	1260cc	78mm*	+6mm	13.5:1	239g	130299	625-472	607-116	607-204
GS1100 (Dome)	81-83	1295cc	79mm**	+7mm	13.5:1	227g	127402	625-473	607-117	607-205
GS1100 (Dome)	81-83	1327cc	80mm**	+8mm	13.5:1	239g	130300	625-474	607-118	607-215
GS1100 (Dome)	81-83	1394cc	82mm**	+10mm	13.5:1	247g	130301	625-475	607-119	607-215
GS1100 (Dome)	81-83	1428cc	83mm**	+11mm	13.5:1	248g	130302	625-476	607-120	607-215
GS1100 (Dome)	81-83	1500cc	85mm**	+13mm	14.0:1	272g	138271	625-477	607-125	607-205
GS1100 (Dome)	81-83	1570cc	87mm	+14mm	15.0:1	298g	146085	625-479	_____	_____

# Piston Kits

## Suzuki

Model	Year	Displ.	Bore	Over Size	Comp. Ratio	Weight	JE Kit #	Piston Kit #	Head Gasket #	Base Gasket#
GS1100 (Flat Top)	81-83	1134cc	74mm	+2mm	10.25:1	209g	125491	625-450	607-100	607-203
GS1100 (Flat Top)	81-83	1170cc	75mm	+3mm	10.25:1	211g	125490	625-451	607-100	607-203
GS1100 (Flat Top)	81-83	1197cc	76mm*	+4mm	10.25:1	222g	128323	625-452	607-101	607-204
GS1100 (Flat Top)	81-83	1260cc	78mm*	+6mm	10.5:1	232g	128324	625-453	607-102	607-204
GS1100 (Flat Top)	81-83	1327cc	80mm**	+8mm	11.0:1	237g	129310	625-454	607-103	607-215
GS1100 (Flat Top)	81-83	1360cc	81mm**	+9mm	11.25:1	240g	129311	625-455	607-145	607-215
GS1100 (Flat Top)	81-83	1394cc	82mm**	+10mm	11.5:1	250g	129312	625-456	607-119	607-215
GS1100 (Flat Top)	81-83	1428cc	83mm**	+11mm	11.7:1	261g	129313	625-457	607-120	607-215
GS1100 (Flat Top)	81-83	1463cc	84mm**	+12mm	11.8:1	262g	129314	625-458	607-128	607-215
GS1100 (Flat Top)	81-83	1500cc	85mm**	+13mm	12.0:1	270g	129315	625-459	607-125	607-205
GSXR1100W	93-98	1117cc	77mm	+1.5mm	12.3:1	219g	131367	625-445	607-137	607-244
GSXR1100W	93-98	1146cc	78mm	+2.5mm	12.8:1	228g	155930	625-448	_____	_____
GSXR1100W	93-98	1195cc	79.5mm	_____	13.0:1	224g	129682	625-446	607-138	607-244
GSXR1100	89-92	1127cc	78mm	STD	13.0:1	232g	129855	625-430	607-146	607-245
GSXR1100	89-92	1186cc	80mm	+2mm	13.0:1	225g	127641	625-431	607-153	607-245
GSXR1100	89-92	1201cc	80.5mm	+2.5mm	13.0:1	233g	155544	625-439	_____	_____
GSXR1100	89-92	1216cc	81mm	+3mm	13.0:1	236g	127642	625-432	607-136	607-246
GSXR1100	89-92	1246cc	82mm*	+4mm	13.0:1	244g	128885	625-433	607-147	607-246
GSXR1100	89-92	1277cc	83mm*	+5mm	13.0:1	236g	127643	625-434	607-147	607-247
GSXR1100	89-92	1277cc	83mm*	+5mm	15.0:1	232g	132495	625-435	607-147	607-247
GSXR1100	89-92	1340cc	85mm*	+7mm	13.0:1	244g	127644	625-436	607-151	607-247
GSXR1100	89-92	1340cc	85mm*	+7mm	15.0:1	245g	130894	625-437	607-151	607-247
GSXR1100	89-92	1371cc	86mm*	+8mm	13.5:1	258g	127645	625-438	607-127	607-247
GS1150 (Dome)	84-85	1197cc	76mm	_____	13.5:1	226g	131097	625-500	607-115	607-204
GS1150 (Dome)	84-85	1327cc	80mm	+6mm	13.5:1	240g	134358	625-501	607-118	607-215
GS1150 (Dome)	84-85	1428cc	83mm	+9mm	13.5:1	265g	134360	625-503	607-120	607-215
GS1150 (Dome)	84-85	1500cc	85mm	+11mm	14.0:1	248g	138329	625-504	607-125	607-205
GS1150 (Flat Top)	84-85	1327cc	80mm	+6mm	11.0:1	236g	134355	625-490	607-118	607-215
GS1150 (Flat Top)	84-85	1394cc	82mm	+8mm	11.5:1	261g	134356	625-491	607-119	607-215
GS1150 (Flat Top)	84-85	1428cc	83mm	+9mm	11.7:1	241g	134357	625-492	607-120	607-215
GS1150 (Flat Top)	84-85	1500cc	85mm	_____	12.0:1	254g	136857	625-493	607-125	607-205
GSX1300R Hayabusa	99-07	1299cc	81mm	STD	12.5:1	239g	167679	625-515	_____	_____
GSX1300R Hayabusa	99-07	1363cc	83mm	+2mm	12.8:1	248g	167680	625-516	_____	_____
GSX1300R Hayabusa	99-07	1397cc	84mm	+3mm	13.0:1	246g	172945	625-517	_____	_____

## Yamaha

YZ250F/WR250F	01-04	249cc	77mm	STD	13.5:1	170g	221798	_____	_____	_____
YZ250F/WR250F	01-04	262cc	79mm	+2mm	13.0:1	181g	247943	_____	_____	_____
YZ400F/WR400F	98-99	399cc	92mm	STD	12.5:1	251g	157595	625-225	_____	_____
YZ426F/WR426F	00-01	426cc	95mm	STD	13.5:1	262g	175000	625-230	_____	_____
YZ426F/WR426F	00-01	446cc	97mm	+2mm	12.5:1	277g	175001	625-231	_____	_____
TT500/XT500/SR500	76-81	540cc	90mm	+3mm	11.0:1	342g	130798	625-200	_____	_____
TT600/XT600	84-96	621cc	97mm	+2mm	11.5:1	373g	138330	625-210	_____	_____
YFM660 Grizzly	02-07	660cc	100mm	STD	10.75:1	367g	190253	625-234	_____	_____
YFM660 Grizzly	02-07	686cc	102mm	+2mm	10.75:1	368g	189576	625-235	_____	_____
YFM660 Grizzly	02-07	660cc	100mm	STD	12.0:1	367g	199654	625-236	_____	_____
YFM660 Grizzly	02-07	686cc	102mm	+2mm	12.0:1	368g	201158	625-237	_____	_____
YFM660R Raptor	01-05	660cc	100mm	STD	10.75:1	367g	190253	625-234	_____	_____
YFM660R Raptor	01-05	686cc	102mm	+2mm	10.75:1	368g	189576	625-235	_____	_____
YFM660R Raptor	01-05	660cc	100mm	STD	12.0:1	367g	199654	625-236	_____	_____
YFM660R Raptor	01-05	686cc	102mm	+2mm	12.0:1	368g	201158	625-237	_____	_____
FZ1000 FZ1	01-03	997cc	74mm	STD	13.0:1	177g	174998	625-215	_____	_____
FZR1000	89-95	1040cc	77mm	+1.5mm	12.0:1	204g	138328	625-220	607-139	607-250
RX1	_____	997cc	74mm	STD	13.0:1	177g	174998	625-215	_____	_____
YZF-R1	99-03	997cc	74mm	STD	13.0:1	177g	174998	625-215	_____	_____



## Piston Pin Bearings

Sold each. *Made in Japan.*

### Honda ATV

Model	Year	OEM Reference	Order No.
ATC250R	81-86	91015-357-003	<b>623-900</b>
FL250ROdyssey	81-84	91015-357-003	<b>623-900</b>
TRX250R	86-89	91015-357-003	<b>623-900</b>

### Honda Offroad

CR80R	85-01	91002-GC4-711	<b>623-902</b>
CR80RB	00-01	91002-GC4-711	<b>623-902</b>
CR250R	81-96	91015-357-003	<b>623-900</b>

### Kawasaki ATV

KXF250A1/A2 Tecate 4	87-88	13033-1010	<b>623-930</b>
KXT250A1/A2 Tecate 3	84-85	13033-1010	<b>623-930</b>
KXT250B1/B2 Tecate 3	86-87	13033-1010	<b>623-930</b>

### Kawasaki Offroad

KDX80C1/C2/C3/C4	85-88	13033-1003	<b>623-931</b>
KX80E1/E2/E3/G1/G2	83-87	13033-1003	<b>623-931</b>
KDX250A1/B1/B2/B3/B4	80-84	13033-1010	<b>623-930</b>
KDX250DD1/D2/D3/D4	91-94	13033-1010	<b>623-930</b>
KT250/A2 Trials	74-75	13033-1010	<b>623-930</b>
KX250/A/A3	74-76	13033-1010	<b>623-930</b>
KX250A4/A5/A6/A7/B1	78-82	13033-1010	<b>623-930</b>
KX250C1/C2/D1/D2	83-86	13033-1010	<b>623-930</b>
KX250E1/F1/G1/H1/H2/J1/J2	87-93	13033-1010	<b>623-930</b>
KX250K1/K2/K3/K4/K5/L1/L2	94-00	13033-1010	<b>623-930</b>
F9/A/B/C-350	72-75	13033-1010	<b>623-930</b>

### Suzuki ATV

ALT50D/E	83-84	09263-12015	<b>623-920</b>
LT50E/F/G/H Quadrunner	84-87	09263-12015	<b>623-920</b>
LT250RF/RG Quadracracer	85-86	09263-18021	<b>623-921</b>

### Suzuki Offroad

DS80C/N/T/X/Z/D	78-83	09263-12015	<b>623-920</b>
RM80D-W	83-98	09263-14016	<b>623-902</b>
RL250L/M Trials	74-75	09263-18021	<b>623-921</b>

### Yamaha ATV

YF60S Moto-4	1986	93310-210M0-00	<b>623-910</b>
YT60L/N Tri-Zinger	84-85	93310-210M0-00	<b>623-910</b>
		93310-210L7-00	
YT125G/H/J/K/L/N Tri-Moto	80-85	93310-216L2-00	<b>623-911</b>
YFS200 Blaster	88-95	93310-316H6-00	<b>623-914</b>
YFZ350Banshee	87-95	93310-316H6-00	<b>623-914</b>

### Yamaha Offroad

PW50H/J/K Y-Zinger	81-83	93310-210M0-00	<b>623-910</b>
PW50N/S/T Y-Zinger	85-87	93310-210M0-00	<b>623-910</b>
PW50A-J1 Y-Zinger	90-97	93310-210M0-00	<b>623-910</b>
YZ100C/D/E/F/G/H/J/K	76-83	93310-216L2-00	<b>623-911</b>
DT125B/C	75-76	93310-216L2-00	<b>623-911</b>

### Yamaha Offroad

Model	Year	OEM Reference	Order No.
DT125E/F/G/H	78-81	93310-216L2-00	<b>623-911</b>
IT125G/H	80-81	93310-216L2-00	<b>623-911</b>
MX125A/B/C	74-76	93310-216L2-00	<b>623-911</b>
YZ125X	1976	93310-216L2-00	<b>623-911</b>
YZ125A/B/C/D/E/F/G/H	74-81	93310-216L2-00	<b>623-911</b>
YZ125J/K/L/N/S/T/U/W/A	82-90	93310-216L2-00	<b>623-911</b>
IT200L/N/S	84-86	93310-316H6-00	<b>623-914</b>
YZ250L/M/N/P/R/S1/T1/V/W	99-07	93310-218A6-00	<b>623-900</b>

### Kawasaki Personal Watercraft

Model	Year	OEM Reference	Order No.
JS300A1-A5 300 SX	87-91	13033-1010	<b>623-930</b>
JS300B1/B2/B3	86-88	13033-1010	<b>623-930</b>
JB650A1/A2/A3/A4 Jet Mate	89-92	13033-1010	<b>623-930</b>
JF650A1-A10 650 X2	86-95	13033-1010	<b>623-930</b>
JF650B1-B8 Tandem Sport	89-96	13033-1010	<b>623-930</b>
JL650-A1/A2/A3/A4/A5 SC	91-95	13033-1010	<b>623-930</b>
JS650A1/A2/A3/A4 650 SX	87-90	13033-1010	<b>623-930</b>
JS650B1/B2/B3 650 SX	91-93	13033-1010	<b>623-930</b>



## Sudco Part Number to OEM Cross Reference

### Honda

OEM Reference	Dimensions	Order No.
91015-357-003	18 x 22 x 22mm	<b>623-900</b>
91002-GC4-711	14 x 18 x 16mm	<b>623-902</b>

### Kawasaki

13033-1010	18 x 22 x 23.8mm	<b>623-930</b>
13033-1003		<b>623-931</b>

### Suzuki

09263-12015		<b>623-920</b>
09263-18021	18 x 23 x 24mm	<b>623-921</b>
09263-14016	14 x 18 x 16mm	<b>623-902</b>

### Yamaha

93310-210M0-00		<b>623-910</b>
93310-216L2-00	17 x 20 x 20mm	<b>623-911</b>
93310-316H6-00	16 x 21 x 23mm	<b>623-914</b>
93310-218A6-00	18 x 22 x 22mm	<b>623-900</b>

# Piston Kits



## ART ATV Piston Kits

All ART Piston Kits come with piston, ring set, wrist pin, and PIN clips.  
*Made in Japan.*

### Honda

Application	Year	Piston Size	Piston Kit	Rings
ATC110 <b>(Std. Bore 52mm)</b>	81-85	Std	_____	_____
		.25mm	_____	<b>624-011R</b>
		.50mm	_____	<b>624-012R</b>
		.75mm	_____	<b>624-013R</b>
		1.00mm	_____	_____
		1.25mm	_____	<b>624-015R</b>
		1.50mm	_____	<b>624-016R</b>
ATC185	1980	Std	_____	_____
ATC185C	80-83	.25mm	_____	<b>624-021R</b>
XL185S (rings only)	79-83	.50mm	_____	_____
XR185 (rings only)	1979	.75mm	_____	<b>624-023R</b>
<b>(Std. Bore 63mm)</b>		1.00mm	_____	_____
		1.25mm	_____	<b>624-025R</b>
		1.50mm	_____	<b>624-026R</b>
ATC200	81-83	Std	_____	_____
ATC200E	82-83	.25mm	_____	_____
ATC200ES	1984	.50mm	_____	_____
ATC200M	84-85	.75mm	_____	<b>624-043R</b>
ATC200S	84-86	1.00mm	_____	<b>624-044R</b>
TRX200 Fourtrax200	1984	1.25mm	_____	<b>624-045R</b>
<b>(Std. Bore 65mm)</b>		1.50mm	_____	<b>624-046R</b>
ATC250ES Big Red	85-87	Std	_____	_____
ATC250SX	85-87	.25mm	_____	_____
TRX250 Fourtrax 250	85-87	.50mm	_____	<b>624-062R</b>
<b>(Std. Bore 74mm)</b>		.75mm	_____	<b>624-063R</b>
		1.00mm	_____	<b>624-064R</b>
(				
ATC250R	81-83	Std	_____	<b>624-050R</b>
<b>(Std. Bore 70mm)</b>		.25mm	_____	<b>624-051R</b>
		.50mm	_____	<b>624-052R</b>
		.75mm	_____	<b>624-053R</b>
		1.00mm	_____	<b>624-054R</b>
		1.25mm	_____	<b>624-055R</b>
		1.50mm	_____	<b>624-056R</b>
ATC250R	1984	Std	_____	<b>624-080R</b>
<b>(Std. Bore 70mm)</b>		.25mm	_____	<b>624-081R</b>
		.50mm	_____	<b>624-082R</b>
		.75mm	_____	<b>624-083R</b>
		1.00mm	_____	<b>624-084R</b>
ATC250R	85-86	Std	<b>624-070</b>	<b>624-070R</b>
TRX250R Fourtrax	85-86	.25mm	_____	<b>624-071R</b>
<b>(Std. Bore 66mm)</b>		.50mm	_____	<b>624-072R</b>
		.75mm	_____	<b>624-073R</b>
		1.00mm	_____	_____
		1.25mm	_____	<b>624-075R</b>
		1.50mm	_____	<b>624-076R</b>
FL250 Odyssey	77-84	Std	_____	<b>624-150R</b>
<b>(Std. Bore 70mm)</b>				

### Kawasaki

Application	Year	Piston Size	Piston Kit	Rings
KXT250B1/B2 Tecate	86-87	Std.	<b>624-601</b>	<b>624-601R</b>
KX250D2	1986			
<b>(Std. Bore 70mm)</b>				
KX250C1/C2/D1	83-85	Std	_____	<b>624-602R</b>

### Suzuki

ALT125D/E/F/G	83-86	.25mm	<b>624-411</b>	<b>624-411R</b>
LT125D/E/F/G/H	83-87	.50mm	_____	_____
<b>(Std. Bore 57mm)</b>		.75mm	<b>624-413</b>	<b>624-413R</b>
		1.00mm	_____	<b>624-414R</b>
ALT185	1985	.25mm	<b>624-401</b>	<b>624-401R</b>
LT185	84-87	.50mm	_____	<b>624-402R</b>
		.75mm	<b>624-403</b>	<b>624-403R</b>
		1.00mm	_____	<b>624-404R</b>
LT230GEF/GEG	85-86	Std	_____	_____
LT230EH/EJ/EK/EL	87-90	.25mm	_____	_____
LT230EM/EN/EP QuadSport	91-93	.50mm	_____	_____
LTF230G/H QuadSport	86-87	.75mm	_____	<b>624-423R</b>
<b>(Std. Bore 66mm)</b>		1.00mm	_____	<b>624-424R</b>
LT250RF/RG Quadracer	85-86	Std	<b>624-430</b>	<b>624-430R</b>
<b>(Std. Bore 70mm)</b>		.25mm	_____	_____
		.50mm	<b>624-432</b>	<b>624-432R</b>
		.75mm	<b>624-433</b>	<b>624-433R</b>
		1.00mm	<b>624-434</b>	<b>624-434R</b>
		1.25mm	<b>624-435</b>	<b>624-435R</b>
		1.50mm	<b>624-436</b>	<b>624-436R</b>
LT250RH/RJ/RK Quadracer	87-89	.25mm	_____	<b>624-481R</b>
LT250RL/RM/RN	90-92	.50mm	<b>624-482</b>	_____
<b>(Std. Bore 67mm)</b>		.75mm	<b>624-483</b>	<b>624-433R</b>
		1.00mm	_____	_____
		1.25mm	<b>624-485</b>	_____
		1.50mm	<b>624-486</b>	_____
LT500RH/RJ Quadracer	87-88	Std	_____	<b>624-440R</b>
LT500RK/RL Quadracer	89-90	.25mm	<b>624-441</b>	<b>624-441R</b>
<b>(Std. Bore 86mm)</b>		.50mm	<b>624-442</b>	<b>624-442R</b>
		.75mm	<b>624-443</b>	<b>624-443R</b>
		1.00mm	<b>624-444</b>	<b>624-444R</b>

### Yamaha

YFM200DXS/DXT Moto-4	86-87	Std	_____	<b>624-200R</b>
YFM200DU/DXW Moto-4	88-89	.25mm	_____	<b>624-201R</b>
YTM200K/L/N Tri-Moto	83-85	.50mm	_____	<b>624-202R</b>
YTM200EK/EL Tri-Moto	83-84	.75mm	_____	<b>624-203R</b>
YTM200ERN Tri-Moto	1985	1.00mm	_____	<b>624-204R</b>
<b>(67mm bore)</b>				
YFM225S/T/U Moto-4	86-88	Std	_____	_____
YTM225DXK/DXL Moto-4	83-84	.25mm	<b>624-211</b>	<b>624-211R</b>
YTM225DXN Tri-Moto	1985	.50mm	<b>624-212</b>	<b>624-212R</b>
YTM225DRN/DRS Tri-Moto	85-86	.75mm	<b>624-213</b>	<b>624-213R</b>
<b>(70mm bore)</b>		1.00mm	<b>624-214</b>	<b>624-214R</b>
YTZ250N Tri-Z	1985	Std	_____	<b>624-220R</b>
<b>(68mm bore)</b>		.25mm	_____	<b>624-221R</b>
		.50mm	_____	<b>624-222R</b>
		.75mm	_____	<b>624-223R</b>
		1.00mm	_____	<b>624-224R</b>



## Shindy Products ATV Piston Kits

High quality replacement piston kits meet or exceed OEM specifications. Kits include piston, ring set, wrist pin and circlips. **Made in Japan.**

### Honda

Model	Year	Size	Piston Kit	Replacement Piston Rings
TRX400FM Fourtrax Foreman	2002	Std.	———	<b>627-100R</b>
TRX400FW Fourtrax Foreman	95-01	0.25	———	<b>627-101R</b>
TRX400FW Fourtrax Foreman	2003	0.50	———	———
		0.75	———	———
		1.00	<b>627-104</b>	———

### Kawasaki

KLF220A1-A15 Bayou 220	88-02	Std.	———	———
		0.25	———	———
		0.50	<b>627-602</b>	———
		0.75	———	———
		1.00	———	———

KEF300A1-A6 Lakota 300	95-00	Std.	———	———
KEF300B1-B3 Lakota Sport	01-03	0.25	———	———
KLF300B1-B17 Bayou 300	88-04	0.50	<b>627-612</b>	———
KLF300C1-C16 Bayou 4x4	89-04	0.75	———	———
KVF300A1-A4 Prairie 4x4	99-02	1.00	———	———
KVF300B1-B4 Prairie 300	99-02		———	———

### Yamaha

YFB250D-H Timberwolf 2WD	92-96	Std.	<b>627-200</b>	———
YFB250FW Timberwolf 4WD	94-00	0.25	<b>627-201</b>	———
YFB250U Timberwolf 2WD	96-98	0.50	———	———
YFM250B Bruin 250 2WD	05-06	0.75	———	———
YFM250W/A/B Moto-4	89-01	1.00	———	———
YFM250X Beartracker	99-04		———	———

YFM350ERT-ERG Moto-4	87-95	Std.	———	<b>627-210R</b>
YFM350FW Big Bear 4WD	87-99	0.25	———	———
YFM350FXG-FXT Wolverine	95-05	0.50	———	———
YFM350U Big Bear 2WD	96-99	0.75	———	———
YFM350XT-XS/XSC Warrior	87-04	1.00	———	———

YFM400FW-FWK Kodiak 4WD	87-98	Std.	———	<b>627-210R</b>
YFM400FWB Kodiak 4WD	1999	0.25	———	———
YFM400FAH Kodiak 4WD Hunter	2000	0.50	———	———
YFM400FA Kodiak 4WD	2000	0.75	———	———
		1.00	———	———

## Piston Rings

**Made in Japan** to OEM specifications. Sold in sets for one piston. Order qt required. Use with OEM Pistons.

### Honda

Model	Year	Size	OEM Reference	Order No.
CB900C Custom	80-82	0.25	13021-438-004	<b>624-115R</b>
CB900F Super Sport	81-82	0.25	13021-438-004	<b>624-115R</b>
CBX (1047cc)	79-82	0.25	13021-438-004	<b>624-115R</b>
GL1000K Goldwing	75-79	0.25	13021-371-004	<b>624-120R</b>
GL1000L Goldwing LTD	1976	0.25	13021-371-004	<b>624-120R</b>
GL1100 Goldwing	80-83	0.25	13021-463-000	<b>624-124R</b>
GL1100A Aspencade	82-83	0.25	13021-463-000	<b>624-124R</b>
GL1100I Interstate	80-83	0.25	13021-463-000	<b>624-124R</b>

### Kawasaki

KZ400A1/A2 Deluxe	77-78	0.50	13025-5013	<b>624-651R</b>
KZ400D/D3/D4	75-77	0.50	13025-5013	<b>624-651R</b>
KZ400S/S2/S3 Special	75-77	0.50	13025-5013	<b>624-651R</b>
KZ440A1/A2/A3/A4 LTD	80-83	0.50	13025-5015	<b>624-654R</b>
KZ440B1/B2	80-81	0.50	13025-5015	<b>624-654R</b>
KZ440D1/D2/D3/D4/D5 LTD Belt	80-83	0.50	13025-5015	<b>624-654R</b>
KZ440G1 Belt	1983	0.50	13025-5015	<b>624-654R</b>
H2/A/B/C-750 Mach IV	72-75	0.50	13025-045	<b>624-675R</b>

### Suzuki

GS450ET/EX/EZ	80-82	0.50	12140-44110-050	<b>624-451R</b>
GS450GAZ/GAD Automatic	82-83	0.50	12140-44110-050	<b>624-451R</b>
GS450GAF Automatic	1985	0.50	12140-44110-050	<b>624-451R</b>
GS450LT/LX/LZ/LD	80-83	0.50	12140-44110-050	<b>624-451R</b>
GS450LF/LG/LH/LJ	85-88	0.50	12140-44110-050	<b>624-451R</b>
GS450TX/TZ/TXZ/TXD	81-83	0.50	12140-44110-050	<b>624-451R</b>
GS550B/C/EC/N/EN/ET	77-80	0.50	12140-47031-050	<b>624-454R</b>
GS550LN/LT/LX/LZ	79-82	0.50	12140-47031-050	<b>624-454R</b>
GS550MZ	1982	0.50	12140-47031-050	<b>624-454R</b>
GS550TX	1981	0.50	12140-47031-050	<b>624-454R</b>
GS850GN/GT/GX/GZ/GD	79-83	0.50	12140-45120-050	<b>624-466R</b>
GS850GLT/GLX/GLZ/GLD	80-83	0.50	12140-45120-050	<b>624-466R</b>
GS1000C /EC/N/EN	78-79	0.50	12140-49001-050	<b>624-469R</b>
GS1000ET	1980	0.50	12140-49001-050	<b>624-469R</b>
GS1000GT/GX	80-81	0.50	12140-49001-050	<b>624-469R</b>
GS1000LN	1979	0.50	12140-49001-050	<b>624-469R</b>
GS1000SN/ST	80-81	0.50	12140-49001-050	<b>624-469R</b>
GS1100ET/EX/EZ/ED	80-83	0.50	12140-49220-050	<b>624-472R</b>
GS1100GZ/GLZ/GD/GLD	82-83	0.50	12140-49220-050	<b>624-472R</b>

### Yamaha

RD400C/D/E/F	76-79	0.25	1A1-11601-25-00	<b>624-251R</b>
XV750H/J/K Virago	81-83	Std.	4X7-11610-00-00	<b>624-271R</b>
XV750MK Midnight Virago	1983	Std.	4X7-11610-00-00	<b>624-271R</b>

# Connecting Rod Kits



## Vesrah Connecting Rod Kits

Vesrah connecting rod kits include connecting rod, crank pin bearing, crank pin, thrust washers (as required) and piston pin bearing for 2-stroke. *Made in Japan.. († Thrust washers not in kit)*

### Honda ATV

Model	Year	Vesrah Ref.	Order No.
ATC70*	78-85	VA-1001	623-001
TRX70*	86-87	VA-1001	623-001
ATC90/K1/K2/K3*	70-75	—	623-050
ATC90*	76-78	—	623-050
ATC110*	82-85	VA-1003	623-003
ATC185	1980	VA-1005	623-005
ATC185S	81-83	VA-1005	623-005
ATC200	81-83	VA-1005	623-005
ATC200E	82-83	VA-1005	623-005
ATC200ES	1984	VA-1005	623-005
ATC200M	84-85	VA-1005	623-005
ATC200S	84-86	VA-1005	623-005
ATC200X	83-85	VA-1005	623-005
TRX200 Fourtrax 200	1984	VA-1005	623-005
TRX200 Fourtrax 200	90-91	VA-1012	623-012
TRX200D Fourtrax 200 Type II	91-97	VA-1012	623-012
TRX200SX	86-88	VA-1012	623-012
ATC250ES Big Red	85-87	VA-1014	623-014
ATC250R	81-84	VA-1006	623-006
ATC250R	85-86	VA-1009	623-009
ATC250SX	85-87	VA-1014	623-014
TRX250 Four Trax	85-87	VA-1014	623-014
TRX250 Recon	97-01	VA-1015	623-015
TRX250EX Sportrax 250EX	01-06	VA-1015	623-015
TRX250R Four Trax 250R	1986	VA-1009	623-009
TRX250TE Fourtrax Recon ES	02-06	VA-1015	623-015
TRX250TE Recon	2006	VA-1015	623-015
TRX250TM Fourtrax Recon	02-06	VA-1015	623-015
TRX250X Four Trax	87-88	VA-1013	623-013
TRX250X Four Trax	91-92	VA-1013	623-013
TRX300 Four Trax	88-00	VA-1010	623-010
TRX300EX Four Trax	93-00	VA-1010	623-010
TRX300EX Sport Trax	01-06	VA-1010	623-010
TRX300FW FourTrax 300	1988	VA-1010	623-010
TRX300FW FourTrax 300	90-00	VA-1010	623-010
ATC350X	85-86	VA-1011	623-011
TRX350 Fourtrax 4x4	86-87	VA-1011	623-011
TRX350D Fourtrax Foreman 4x4	86-87	VA-1011	623-011
TRX400FW Fourtrax Foreman	95-01	VA-1017	623-017
TRX450ES Fourtrax Foreman ES	98-01	VA-1017	623-017
TRX450S Fourtrax Foreman S	98-01	VA-1017	623-017

### Honda Offroad

Model	Year	Vesrah Ref.	Order No.
CR80R	86-02	VA-5009	623-5009
CR80RB	00-02	VA-5009	623-5009
CR85R	03-07	VA-5009	623-5009
CR85RB	03-07	VA-5009	623-5009
CR125R	90-07	VA-5014	623-5014
XR185	1979	VA-1005	623-005
XL185S	79-83	VA-1005	623-005
CR250R	81-01	VA-5001	623-5001
CR250R	02-07	VA-5015	623-5015
CRF250R	04-06	VA-5016	623-5016
CR500R	87-01	VA-5004	623-5004

### Kawasaki Street

KZ200A1/A1A/A2	78-79	VA-4001	623-601
KZ250W1 LTD Belt	1983	VA-4004	623-604
H1/A/B/C/D/E/F-500 Mach II	69-75	VA-4902	623-699
KH500A8	1976	VA-4902	623-699
H2/A/B/C-750 Mach IV	72-75	VA-4801	623-698

**623-698 H2 Rod Kit does not include the piston pin bearing**

### Kawasaki ATV

KSF50A1/A2/A3/A6F KFX 50*	03-06	VA-3001	623-401
KSF80A1/A2/A3/A6F KFX80	03-06	VA-3008	623-408
KLF110A1/A2 Mojave	86-87	VA-4006	623-606
KLF110B1/B2 Mojave	86-87	VA-4006	623-606
KLT110A1/A2/A3	84-86	VA-4006	623-606
KLT160A1	1985	VA-4007	623-607
KLT200A1/A2/A3/A4/A4A	81-83	VA-4001	623-601
KLT200B1	1983	VA-4002	623-602
KLT200C1/C2	83-84	VA-4002	623-602
KLF220A1-A15 Bayou 220*	88-02	VA-4009	623-4009
KLF250A1-A3/A6F/A7F Bayou 250*	03-07	VA-4009	623-4009
KLT250A1	1982	VA-4003	623-603
KLT250A2	1983	VA-4004	623-604
KLT250C1/C2/C3 Prairie 250	83-85	VA-4004	623-604
KLT250P1 Police	1984	VA-4004	623-604
KEF300A1-A6 Lakota 300	95-00	VA-4008	623-608
KEF300B1/B2/B3 Lakota Sport	01-03	VA-4008	623-608
KLF300A1/A2 Bayou 300	86-87	VA-4008	623-608
KLF300B1-B17 Bayou 300	88-04	VA-4008	623-608
KLF300C1-C16 Bayou 300 4x4	89-04	VA-4008	623-608
KVF300A1-A4 Prairie 300 4x4	99-02	VA-4008	623-608
KVF300B1-B4 Prairie 300	99-02	VA-4008	623-608

### Kawasaki Dual Sport & Offroad

KX60A1/A2	83-84	VA-8007	623-8007
KX60B1-B14	85-98	VA-8007	623-8007
KX60B15/B16/B17/B18/B19	99-03	VA-7017	623-7017
KX65A1/A2/A3/A4/A5/A6/A6F/A7F	00-07	VA-7017	623-7017
KDX80C1/C2/C3/C4/C5	84-88	VA-8006	623-8006
KX80E2/E3	84-85	VA-8006	623-8006
KX80G1/G2	86-87	VA-8006	623-8006
KX80J2 Big Wheel	1987	VA-8006	623-8006
KX80L1/L2/L3	88-90	VA-8006	623-8006
KX80N1/N2/N3	88-90	VA-8006	623-8006
KX80R1-R7	91-97	VA-8006	623-8006
KX80T1-T4 Big Wheel	91-94	VA-8006	623-8006
KX80W1/W2/W3	98-00	VA-8009	623-8009
KX85A1/A2/A3/A4/A5/A6F/A7F	01-07	VA-8009	623-8009
KX100B5/B6/B7	95-97	VA-8006	623-8006
KX100C1/C2/C3	98-00	VA-8009	623-8009
KX100D1/D2/D3/D4/D5/D6F/D7F	01-07	VA-8009	623-8009
KX125K1/K2/K3/K4	94-97	VA-8003	623-8003



## Kawasaki Dual Sport & Offroad

Model	Year	Vesrah Ref.	Order No.
KX125K5	1998	VA-8008	<b>623-8008</b>
KX125L1/L2/L3/L4	99-02	VA-8008	<b>623-8008</b>
KX125M1/M2/M3	03-05	VA-8010	
KDX250D1/D2/D3/D4	91-94	VA-8002	<b>623-8002</b>
KL250A1/A1A/A2/A3/A4 Dual Sport	78-81	VA-4003	<b>623-603</b>
KL250C1 Dual Sport	1983	VA-4004	<b>623-604</b>
KLX250A1/A2	79-80	VA-4003	<b>623-603</b>
KX250C1/C2	83-84	VA-8002	<b>623-8002</b>
KX250D1/D2	85-86	VA-8002	<b>623-8002</b>
KX250F1/G1	88-89	VA-8002	<b>623-8002</b>
KX250H1/H2	90-91	VA-8002	<b>623-8002</b>
KX250J1/J2	92-93	VA-8002	<b>623-8002</b>
KX250K1/K2/K3/K4/K5	94-98	VA-8002	<b>623-8002</b>
KX250L1/L2/L3	99-01	VA-8002	<b>623-8002</b>
KX250L4	2002	VA-8011	<b>623-8011</b>
KX250M1/M2	03-04	VA-8011	<b>623-8011</b>
KX250R1/R6F/R7F	05-07	VA-8011	<b>623-8011</b>
KX500A1/A2/B1/B2	83-86	VA-8001	<b>623-8001</b>
KX500C1/D1	87-88	VA-8001	<b>623-8001</b>
KX500E1-E16	89-04	VA-8001	<b>623-8001</b>

## Suzuki ATV

ALT50D/E Quadrunner*	83-84	VA-3001	<b>623-401</b>
LT-A50K2/K3/K4/K5*	02-05	VA-3001	<b>623-401</b>
LT50E/F/G/H*	84-90	VA-3001	<b>623-401</b>
LT80H-Y Quadrunner	87-00	VA-3008	<b>623-408</b>
LT80K1/K2/K3/K4/K5/K6 Quadport	01-06	VA-3008	<b>623-408</b>
ALT125D/E/F/G 3x6*	83-86	VA-3002	<b>623-402</b>
LT125D/E/F/G/H Quadrunner*	83-87	VA-3002	<b>623-402</b>
LT230EH-EP Quadrunner	87-93	VA-3004	<b>623-404</b>
LT230GEF/GEG Quadrunner	85-86	VA-3004	<b>623-404</b>
LT230SF/SG/SH/SJ Quadport 230	85-88	VA-3004	<b>623-404</b>
LT-F230G/H	86-87	VA-3004	<b>623-404</b>
LT250EFF/EFQ Quadrunner*	85-86	VA-3005	<b>623-405</b>
LT250RF/RG Quadrunner	85-86	VA-3003	<b>623-403</b>
LT-4WDH-WDW 4x4*	87-98	VA-3005	<b>623-405</b>
LT-F250J-K1 Quadrunner 250*	88-01	VA-3005	<b>623-405</b>
LT-F250K2/K3/K4/K5/K6 Ozark*	02-06	VA-3005	<b>623-405</b>
LT-F250FX/FY/FK1/FK2 Quadrunner*	99-02	VA-3005	<b>623-405</b>
LTF300FX-FK2 King Quad	99-02	VA-3006	<b>623-406</b>
LT-F4WDXM-WDXW King Quad	91-98	VA-3006	<b>623-406</b>
LT-A500FY/FK1 Quadmaster	00-01	VA-3009	<b>623-409</b>
LT-A500FK2-FK6 Vinson 4WD	02-06	VA-3009	<b>623-409</b>

## Suzuki Offroad

JR50C-K6*	78-06	VA-3001	<b>623-401</b>
RM60K3	2003	VA-8007	<b>623-8007</b>
RM65K3/K4/K5	03-05	VA-8007	<b>623-8007</b>
RM80L/M/N/P/R/S	90-95	VA-7010	<b>623-7010</b>
RM80T/V/W/Y/K1	96-01	VA-7010	<b>623-7010</b>
RM125N/P/R/S/T	92-96	VA-7004	<b>623-7004</b>
RM125V/W	97-98	VA-7014	<b>623-7014</b>
RM125X/Y/K1/K2/K3	99-03	VA-7015	<b>623-7015</b>
RM250N/P/R/S	92-95	VA-7001	<b>623-7001</b>
RM250T/V/W/X/Y	96-00	VA-7013	<b>623-7013</b>
RM250K1/K2/K3/K4/K5/K6	01-06	VA-7013	<b>623-7013</b>
RMX250K/L/M/N/P	89-93	VA-7001	<b>623-7001</b>
RMX250R/S/T/V/W	94-98	VA-7001	<b>623-7001</b>

## Yamaha ATV

Model	Year	Vesrah Ref.	Order No.
YF60S 4-Zinger*	1986	VA-2001	<b>623-201</b>
YT60L/N Tri-Zinger*	84-85	VA-2001	<b>623-201</b>
YT125G-N Tri Moto	80-85	VA-2002	<b>623-202</b>
YFS200U-V Blaster	88-06	VA-2009	<b>623-209</b>
YFS200SEV Blaster	2006	VA-2009	<b>623-209</b>
YFM225S/T/U Moto-4*	86-88	VA-2005	<b>623-205</b>
YTM225DRN/DRS Tri-Moto*	85-86	VA-2005	<b>623-205</b>
YTM225DXK/DXL/DXN Tri-Moto*	83-85	VA-2005	<b>623-205</b>
YFB250D/E/F/G/H/J Timberwolf*	92-97	VA-2005	<b>623-205</b>
YFB250FWF-FWM/FWMC 4x4*	94-00	VA-2005	<b>623-205</b>
YFB250UH/UJ/UK Timberwolf*	96-98	VA-2005	<b>623-205</b>
YFM250W/A/B Moto-4*	89-91	VA-2005	<b>623-205</b>
YFM250M/MC Beartracker*	2000	VA-2005	<b>623-205</b>
YFM250XL/XLC/XM/XMC*	99-00	VA-2005	<b>623-205</b>
YFM250XN/XHN*	2001	VA-2005	<b>623-205</b>
YFM250XP/XR/XS Beartracker*	02-04	VA-2005	<b>623-205</b>
YTZ250N/S Tri-Z	85-86	VA-6003	<b>623-6003</b>
YFZ350T-V Banshee	87-06	VA-2008	<b>623-208</b>
YFZ350LER/LES	03-04	VA-2008	<b>623-208</b>
YFZ350RB Banshee	2003	VA-2008	<b>623-208</b>
YFZ350SET/SEV	05-06	VA-2008	<b>623-208</b>
YFZ350SPV Banshee	2006	VA-2008	<b>623-208</b>

## Yamaha Offroad

PW50A-V Y-Zinger*	90-06	VA-2001	<b>623-201</b>
YZ80E1/F1/G1/H1	93-96	VA-6008	<b>623-6008</b>
YZ80J1/K1/L1/M1/N1	97-01	VA-6008	<b>623-6008</b>
YZ85P/R/S/T/V	02-06	VA-6008	<b>623-6008</b>
YZ125S/T/U/W/A	86-90	VA-6005	<b>623-6005</b>
YZ125B/D/E/F/G/H	91-96	VA-6005	<b>623-6005</b>
YZ125J1/K1/L1/M1	97-00	VA-6013	<b>623-6013</b>
YZ125N/P/R/S1	01-04	VA-6010	<b>623-6010</b>
XT225D/DC-S/SC Serow*	92-04	VA-2005	<b>623-205</b>
WR250ZB-ZJ	91-97	VA-6002	<b>623-6002</b>
YZ250WRW	1989	VA-6003	<b>623-6003</b>
YZ250WRA	1990	VA-6002	<b>623-6002</b>
YZ250J/K/L/N/S/T/U/W	82-89	VA-6003	<b>623-6003</b>
YZ250A1/B1/D1/E1	90-93	VA-6002	<b>623-6002</b>
YZ250F1/G1/H1/J1/K1	94-98	VA-6002	<b>623-6002</b>
YZ250L1/M1/N1	99-01	VA-6009	<b>623-6009</b>
YZ250P/R/S1/T1/V	02-06	VA-6009	<b>623-6009</b>
WR426FN/FP*	01-02	VA-6012	<b>623-6012</b>
YZ426FM/FN/FP*	00-02	VA-6012	<b>623-6012</b>





## Sudco Oil Filters

Sudco Oil Filters are **Made in Japan** by the same manufacturers who supply oil filters to the OEM manufacturers. Sudco Oil Filters are made to original manufacturer's specifications for fit, performance and quality. Sold each.

### Sudco Part Number to OEM Cross Reference

#### Honda

OEM Reference	Vesrah	Order No.	Notes
154A1-413-005	SF-1002	<b>631-002</b>	Oil Filter only
15410-MB0-003	SF-1004	<b>631-005</b>	Black Spin-on
15410-MCJ-000	SF-4007	—	Black Spin-on
15410-MCJ-003	SF-4007	—	Black Spin-on
15410-MJ0-405	SF-1004	<b>631-005</b>	Black Spin-on
15410-MM9-003	SF-4005	<b>631-009</b>	Black Spin-on
15410-MM9-013	SF-4005	<b>631-009</b>	Black Spin-on
15410-MT7-003	SF-4005	<b>631-009</b>	Black Spin-on
15410-426-010	SF-1001	<b>631-003</b>	With o-rings
15410-426-010	SF-4004	<b>631-001</b>	Oil Filter only
15412-MEN-671	SF-1009	—	Oil Filter only
15412-300-024	SF-4004	<b>631-001</b>	Oil Filter only
15412-413-005	SF-1002	<b>631-002</b>	Oil Filter only

#### Kawasaki

16097-0002	SF-4007	—	Black Spin-on
16097-1002	SF-4003	<b>631-603</b>	Oil Filter only
16097-1054	SF-1004	<b>631-005</b>	Black Spin-on
16097-1061	SF-4005	<b>631-009</b>	Black Spin-on
16097-1063	SF-4005	<b>631-009</b>	Black Spin-on
16097-1064	SF-4006	<b>631-606</b>	Black Spin-on
16097-1065	SF-4006	<b>631-606</b>	Black Spin-on
16097-1066	SF-4006	<b>631-606</b>	Black Spin-on
16097-1070	SF-4007	—	Black Spin-on
16097-1072	SF-4007	—	Black Spin-on
16099-002	SF-4001	<b>631-601</b>	Oil Filter only
16099-003	SF-4004	<b>631-001</b>	Oil Filter only
16099-004	SF-4002	<b>631-602</b>	Oil Filter only
52010-0001	SF-3012	—	Oil Filter only
52010-S001	SF-3003	<b>631-402</b>	Oil Filter only
52010-S002	SF-3007	<b>631-403</b>	Oil Filter only
52010-S004	SF-3011	—	Oil Filter only

### Sudco Part Number to OEM Cross Reference

#### Polaris ATV

OEM Reference	Vesrah	Order No.	Notes
3084963	SF-4005	<b>631-009</b>	Black spin-on

#### Suzuki

16510-03G00	SF-3009	<b>631-405</b>	Black spin-on
16510-03G00-X07	SF-3009	<b>631-405</b>	Black spin-on
16510-05A00	SF-3008	<b>631-404</b>	Black spin-on
16510-05240	SF-3003	<b>631-402</b>	Oil Filter only
16510-06B00	SF-3009	<b>631-405</b>	Black spin-on
16510-24501	SF-3007	<b>631-408</b>	Oil Filter only
16510-25C00	SF-3007	<b>631-403</b>	Oil Filter only
16510-29F00	SF-3011	—	Oil Filter only
16510-34E00	SF-3009	<b>631-405</b>	Black spin-on
16510-37440	SF-3005	<b>631-408</b>	Oil Filter only
16510-37450	SF-3005	<b>631-408</b>	Oil Filter only
16510-38240	SF-3006	<b>631-409</b>	Oil Filter only
16510-45040	SF-3004-2	<b>631-401.5</b>	With o-rings
K1609-71072	SF-4007	—	Black spin-on
K5201-00001	SF-3012	—	Oil Filter only

#### Yamaha

1J7-13441-10-00	SF-2002	<b>631-202</b>	With o-rings
1J7-13440-90-00	SF-2002	<b>631-201</b>	With o-rings
1J7-13440-91-00	SF-2002	<b>631-201</b>	With o-rings
1L9-13440-11-00	SF-2001	<b>631-201</b>	With o-rings
1L9-13440-91-00	SF-2001	<b>631-201</b>	With o-rings
1UY-13440-00-00	SF-2005	<b>631-205</b>	Oil Filter only
1UY-13440-01-00	SF-2005	<b>631-205</b>	Oil Filter only
1UY-13440-02-00	SF-2005	<b>631-205</b>	Oil Filter only
3FV-13440-00-00	SF-4005	<b>631-009</b>	Black spin-on
3FV-13440-10-00	SF-4005	<b>631-009</b>	Black spin-on
3UH-E3440-00-00	SF-2004	<b>631-204</b>	Oil Filter only
36Y-13441-00-00	SF-4004	<b>631-001</b>	Oil Filter only
4X7-13440-00-00	SF-2003	<b>631-203</b>	Oil Filter only
4X7-13440-01-00	SF-2003	<b>631-203</b>	Oil Filter only
4X7-13440-90-00	SF-2003	<b>631-203</b>	Oil Filter only
5DM-13440-00-00	SF-2006	—	Black spin-on
5GH-13440-00-00	SF-4005	<b>631-009</b>	Black spin-on
5H0-13440-00-00	SF-2004	<b>631-204</b>	Oil Filter only
5H0-13440-09-00	SF-2004	<b>631-204</b>	Oil Filter only
5JW-13440-00-00	SF-2007	—	Oil Filter only
5JX-13440-00-00	SF-2003	<b>631-203</b>	Oil Filter only
5RU-13440-00-00	SF-3007	<b>631-403</b>	Oil Filter only
5TA-13440-00-00	SF-2008	—	Oil Filter only



## K&N Oil Filters

K&N Oil Filters are TUV production monitored. Synthetic filter media provides outstanding filtration at high-flow rates with less pressure drop and will not break down with today's synthetic oils. 17mm hex nut on spin-on oil filters for easy wrench-off installation with cross drilled safety wire holes. Higher burst point than OEM with heavy-duty, steel outer construction. (spin-on filters) Anti-drain back valve (where applicable) and pre-lubed base gasket ensures a tight seal. Sold each.

### K&N Part Number to OEM Cross Reference

#### Aprilia

OEM Reference	K&N	Order No.
25 61 85	KN-151	<b>631-7151</b>
02 56 187	KN-152	<b>631-7152</b>
02 64 50	KN-185	<b>631-7185</b>

#### Arctic Cat ATV

3436005	KN-132	<b>631-7132</b>
0436001, 0436146, 3402155	KN-138	<b>631-7138</b>
0436001, 0436146, 3402155	KN-138C	<b>631-7138C</b>
	KN-139	<b>631-7139</b>
	KN-204	<b>631-7204</b>

#### BMW

11412 343 118, 11412 343 452	KN-151	<b>631-7151</b>
11412 337 198, 11421 357 572	KN-161	<b>631-7161</b>
11001 341 616, 11421 460 687, 11421 460 845	KN-163	<b>631-7163</b>
11417 651 414	KN-185	<b>631-7185</b>

#### Bombardier ATV

711256185	KN-151	<b>631-7151</b>
-----------	--------	-----------------

#### Buell

	KN-171B	<b>631-7171B</b>
	KN-171C	<b>631-7171C</b>

#### Cagiva

	KN-153	<b>631-7153</b>
	KN-138	<b>631-7138</b>
	KN-138C	<b>631-7138C</b>

#### Ducati

090549960, 44440034A	KN-153	<b>631-7153</b>
----------------------	--------	-----------------

#### Gas Gas

	KN-112	<b>631-7112</b>
--	--------	-----------------

## Harley Davidson®

OEM Reference	K&N	Order No.
<b>Extra Long Filter</b>		
6381290 Chrome	KN-173C	<b>631-7173C</b>
6381390 Chrome	KN-173C	<b>631-7173C</b>
<b>Long Filter</b>		
6380580A, 6379677A Black with Anti Drain Back Valve	KN-170	<b>631-7170</b>
6380580A, 6379677A Chrome with Anti Drain Back Valve	KN-170C	<b>631-7170C</b>
6373199, 6373199A, 6379899, 6379899A Black without Anti Drain Back Valve	KN-171B	<b>631-7171B</b>
6373199, 6373199A, 6379899, 6379899A Chrome without Anti Drain Back Valve	KN-171C	<b>631-7171C</b>
<b>Short Filter</b>		
6378280 Chrome	KN-172C	<b>631-7172C</b>
6381080A Chrome	KN-172C	<b>631-7172C</b>

## Honda

154A1-413-005	KN-111	<b>631-7111</b>
15410-KF0-315	KN-112	<b>631-7112</b>
15412-HM5-A10	KN-113	<b>631-7113</b>
15412-MEB-671	KN-115	<b>631-7115</b>
15412-MEN-671	KN-116	
15410-MJ0-405 Black Spin-on	KN-202	<b>631-7202</b>
15410-MCJ-003 Black Spin-on	KN-204	<b>631-7204</b>
15410-MM9-013 Black Spin-on	KN-303	<b>631-7303</b>
15410-MM9-013 Chrome Spin-on	KN-303C	<b>631-7303C</b>
15410-426-010	KN-401	<b>631-7401</b>

## Husqvarna

800081675	KN-154	<b>631-7154</b>
-----------	--------	-----------------

## Kawasaki

52010-1053	KN-112	<b>631-7112</b>
16099-004	KN-123	<b>631-7123</b>
16099-002	KN-126	<b>631-7126</b>
52010-S004	KN-139	<b>631-7139</b>
16097-1054 Black Spin-on	KN-202	<b>631-7202</b>
16097-1072 Black Spin-on	KN-204	<b>631-7204</b>
52010-0001	KN-207	<b>631-7207</b>
16097-1066 Black	KN-303	<b>631-7303</b>
16097-1066 Chrome	KN-303C	<b>631-7303C</b>
16099-003	KN-401	<b>631-7401</b>

# Oil Filters

## K&N Part Number to OEM Cross Reference

### KTM

OEM Reference	K&N	Order No.
580 38005000	KN-155	631-7155
590 38045000	KN-156	631-7156
590 38046000	KN-157	631-7157

### Kymco

	KN-147	631-7147
--	--------	----------

### MBK

	KN-143	631-7143
--	--------	----------

### MZ

	KN-145	631-7145
	KN-151	631-7151

### Peugeot

	KN-185	631-7185
--	--------	----------

### Polaris ATV

2540006	KN-196	631-7196
3084963	KN-303	631-7303
3084963	KN-303	631-7303

### Sachs

	KN-145	631-7145
--	--------	----------

### Suzuki

16510-05240	KN-131	631-7131
16510-25C00	KN-132	631-7132
16510-45040	KN-133	631-7133
16510-05A00	KN-134	631-7134
16510-38240	KN-136	631-7136
16510-37450	KN-137	631-7137
16510-03G00-X07	KN-138	631-7138
16510-03G00-X07 Chrome	KN-138C	631-7138C
16510-29F00	KN-139	631-7139
K5201-00001	KN-207	631-7207

### Triumph

T1210200	KN-191	631-7191
1210031T0301	KN-192	631-7192

### Yamaha

5TA-13440-00-00	KN-141	631-7141
1UY-13440-02-00	KN-142	631-7142
5H0-13440-09-00	KN-143	631-7143
1L9-13441-11-00	KN-144	631-7144
5JX-13440-00-00	KN-145	631-7145
4X7-13440-90-00	KN-145	631-7145
1J7-13441-10-00	KN-146	631-7146
5DM-13440-00-00	KN-147	631-7147
5JW-13440-00-00	KN-148	631-7148
3FV-13440-10-00	KN-303	631-7303
5GH-13440-00-00	KN-303	631-7303
3FV-13440-10-00 Chrome	KN-303C	631-7303C
5GH-13440-00-00 Chrome	KN-303C	631-7303C
36Y-13441-00-00	KN-401	631-7401

## Aprilia

Model	Year	Sudco Order No.	K&N Order No.
Leonardo 125	97-04	_____	631-7185
Scarabeo 125	99-03	_____	631-7185
Scarabero 125 GT	02-03	_____	631-7185
Leonardo 150	99-04	_____	631-7185
Scarabero 150	00-02	_____	631-7185
200 Scarabero	02-03	_____	631-7185
200 Scarabero GT	02-03	_____	631-7185
ETX 350	85-90	_____	631-7151
ETX350 Tuareg Wind	88-90	_____	631-7151
Tuareg 600	88-93	_____	631-7151
650 Stark	ALL	_____	631-7152
Moto 650	95-01	_____	631-7151
Pegaso 650	93-00	_____	631-7151
Pegaso 650 I.E.	01-04	_____	631-7151
Pegaso 650 I.E. Tuscany Tibet Raid	2004	_____	631-7151
ETV 1000 Caponord	01-04	_____	631-7152
ETV 1000 Caponord Rally Raid	2004	_____	631-7152
RST 1000 Futura	01-04	_____	631-7152
RSV 1000 R/RSV 1000 R Factory	2005	_____	631-7152
RSV Millie 1000	99-03	_____	631-7152
RSV Millie Factory	2004	_____	631-7152
RSV Millie R 1000	00-04	_____	631-7152
RSV Millie R Nera 1000	2004	_____	631-7152
RSV Millie SP 1000	00-02	_____	631-7152
SL 1000 Falco	00-04	_____	631-7152
Tuono 1000 R	04-05	_____	631-7152
Tuono 1000 R Factory	2005	_____	631-7152
Tuono Fighter 1000	03-04	_____	631-7152
Tuono Racing	2004	_____	631-7152

### Arctic Cat ATV

250 2x4	99-05	_____	631-7132
250 4x4	01-05	_____	631-7132
300 2x4	98-03	_____	631-7132
300 4x4	98-05	_____	631-7132
375 2x4	2002	_____	631-7138
		_____	631-7138C
375 4x4	2002	_____	631-7138
		_____	631-7138C
400 2x4	98-04	_____	631-7138
		_____	631-7138C
400 2x4 Auto	03-04	_____	631-7138
		_____	631-7138C
400 4x4	98-05	_____	631-7138
		_____	631-7138C
400 4x4 ACT	2004	_____	631-7138
		_____	631-7138C
400 4x4 Auto	03-05	_____	631-7138
		_____	631-7138C
400 4x4 Auto ACT	2004	_____	631-7138
		_____	631-7138C
400 4x4 Auto MRP	2003	_____	631-7138
		_____	631-7138C
400 4x4 Auto TBX	04-05	_____	631-7138
		_____	631-7138C
400 DVX 2x4	2004	_____	631-7139
400 DVX	2006	_____	631-7139
454 2x4	96-98	_____	631-7138
		_____	631-7138C
454 4x4	96-98	_____	631-7138
		_____	631-7138C
500 4x4	98-05	_____	631-7138
		_____	631-7138C
500 4x4 Auto	00-05	_____	631-7138
		_____	631-7138C
500 4x4 Auto LE	2005	_____	631-7138
		_____	631-7138C

## Arctic Cat ATV

Model	Year	Sudco Order No.	K&N Order No.
500 4x4 Auto MRP	2003	_____	<b>631-7138</b>
		_____	<b>631-7138C</b>
500 4x4 Auto TBX	02-05	_____	<b>631-7138</b>
		_____	<b>631-7138C</b>
500 4x4 Auto TRV	04-05	_____	<b>631-7138</b>
		_____	<b>631-7138C</b>
500 Standard	99-02	_____	<b>631-7138</b>
		_____	<b>631-7138C</b>
650 4x4 Auto	2004	_____	<b>631-7204</b>
650 4x4 Auto LE	2004	_____	<b>631-7204</b>
650 V-2 4x4	2006	_____	<b>631-7204</b>
650 V-2 4x4 Auto	2005	_____	<b>631-7204</b>
650 V-2 4x4 Auto LE	2005	_____	<b>631-7204</b>
650 V-2 4x4 LE TS	2006	_____	<b>631-7204</b>

## BMW

C1 125	01-02	_____	<b>631-7185</b>
C1 200	2002	_____	<b>631-7185</b>
R45	78-80	_____	<b>631-7161</b>
R45N	78-80	_____	<b>631-7161</b>
R50/5	69-73	_____	<b>631-7161</b>
R60	69-84	_____	<b>631-7161</b>
F650 Funduro	93-00	_____	<b>631-7151</b>
F650 CS	02-05	_____	<b>631-7151</b>
F650 GS	00-05	_____	<b>631-7151</b>
F650 GS Dakar	01-05	_____	<b>631-7151</b>
F650 ST Strada	97-00	_____	<b>631-7151</b>
R65	79-85	_____	<b>631-7161</b>
R65 LS	78-84	_____	<b>631-7161</b>
K75	87-97	_____	<b>631-7163</b>
K75 ABS	1994	_____	<b>631-7163</b>
K75 ABS Special Edition	1994	_____	<b>631-7163</b>
K75 Special Edition	1994	_____	<b>631-7163</b>
K75 /3	1995	_____	<b>631-7163</b>
K75 /3 ABS	1995	_____	<b>631-7163</b>
K75C	85-88	_____	<b>631-7163</b>
K75RT	90-97	_____	<b>631-7163</b>
K75RT ABS	91-95	_____	<b>631-7163</b>
K75S	86-97	_____	<b>631-7163</b>
K75S ABS	91-95	_____	<b>631-7163</b>
K75S ABS Special Edition	1994	_____	<b>631-7163</b>
K75T	1986	_____	<b>631-7163</b>
R75	69-84	_____	<b>631-7161</b>
R80	84-95	_____	<b>631-7161</b>
R80GS	80-95	_____	<b>631-7161</b>
R80R	93-95	_____	<b>631-7161</b>
R80RT	84-95	_____	<b>631-7161</b>
R80ST	82-90	_____	<b>631-7161</b>
R850C	99-02	_____	<b>631-7163</b>
R850C Avantgarde	2001	_____	<b>631-7163</b>
R850C Boxer	2001	_____	<b>631-7163</b>
R850C Classic	2001	_____	<b>631-7163</b>
R850GS Boxer	1999	_____	<b>631-7163</b>
R850R	95-03	_____	<b>631-7163</b>
R850R Boxer	99-01	_____	<b>631-7163</b>
R850RT Boxer	1999	_____	<b>631-7163</b>
R90	1975	_____	<b>631-7161</b>
R90S	69-76	_____	<b>631-7161</b>
K1	89-94	_____	<b>631-7163</b>
K1 ABS	91-93	_____	<b>631-7163</b>
K100	83-90	_____	<b>631-7163</b>
K100LT	83-94	_____	<b>631-7163</b>
K100RS	83-94	_____	<b>631-7163</b>
K100RT	83-94	_____	<b>631-7163</b>
R100CS (w/o Oil Cooler)	73-90	_____	<b>631-7161</b>
R100GS (w/o Oil Cooler)	87-94	_____	<b>631-7161</b>
R100R (w/o Oil Cooler)	87-96	_____	<b>631-7161</b>
R100RS (w/o Oil Cooler)	87-96	_____	<b>631-7161</b>
R100RT (w/o Oil Cooler)	87-96	_____	<b>631-7161</b>
R100S (w/o Oil Cooler)	73-90	_____	<b>631-7161</b>
K1100LT ABS	92-99	_____	<b>631-7163</b>
K1100LT ABS Special Edition	1994	_____	<b>631-7163</b>
K1100RS	90-95	_____	<b>631-7163</b>

## BMW

Model	Year	Sudco Order No.	K&N Order No.
R1100GS ABS	93-99	_____	<b>631-7163</b>
R1100GS PD	1998	_____	<b>631-7163</b>
R1100R	1995	_____	<b>631-7163</b>
R1100R	2001	_____	<b>631-7163</b>
R1100R ABS	95-00	_____	<b>631-7163</b>
R1100RA/S ABS	1995	_____	<b>631-7163</b>
R1100RS ABS	93-01	_____	<b>631-7163</b>
R1100RS ABS Specia; Edition	94-95	_____	<b>631-7163</b>
R1100RT ABS	99-01	_____	<b>631-7163</b>
R1100S	99-05	_____	<b>631-7163</b>
R1100S Replika	04-05	_____	<b>631-7163</b>
R1150GS	99-03	_____	<b>631-7163</b>
R1150GS Adventure	02-04	_____	<b>631-7163</b>
R1150R	01-05	_____	<b>631-7163</b>
R1150R Rockster	04-05	_____	<b>631-7163</b>
R1150RS	02-05	_____	<b>631-7163</b>
R1150RT	01-05	_____	<b>631-7163</b>
K1200C	1999	_____	<b>631-7163</b>
K1200GT	02-05	_____	<b>631-7163</b>
K1200LT	02-05	_____	<b>631-7163</b>
K1200LT ABS	99-02	_____	<b>631-7163</b>
K1200LT SE	2002	_____	<b>631-7163</b>
K120RS	97-04	_____	<b>631-7163</b>
R1200C	1999	_____	<b>631-7163</b>
R1200C Avantgarde	00-03	_____	<b>631-7163</b>
R1200C Classic	01-03	_____	<b>631-7163</b>
R1200C Cruiser	99-01	_____	<b>631-7163</b>
R1200C Independent	01-04	_____	<b>631-7163</b>
R1200C Montauk	2004	_____	<b>631-7163</b>
R1200C Phoenix	2001	_____	<b>631-7163</b>
R1200C Phoenix	2004	_____	<b>631-7163</b>
R1200CL	03-04	_____	<b>631-7163</b>

## Bombardier

Outlander 330 H.O. 2x4	03-05	_____	<b>631-7152</b>
Outlander 330 H.O. 4x4	03-05	_____	<b>631-7152</b>
Outlander 400 H.O. 2x4	03-04	_____	<b>631-7152</b>
Outlander 400 H.O. 4x4	03-06	_____	<b>631-7152</b>
Outlander 400 H.O. 4x4 XT	03-06	_____	<b>631-7152</b>
Outlander Max 400 H.O. 4x4	04-06	_____	<b>631-7152</b>
Outlander Max 400 H.O. 4x4 XT	04-06	_____	<b>631-7152</b>
DS650	2000	_____	<b>631-7151</b>
DS650	01-05	_____	<b>631-7152</b>
DS650 Baja	02-04	_____	<b>631-7152</b>
DS650X	05-06	_____	<b>631-7152</b>
Outlander 800 H.O. EFI	2006	_____	<b>631-7152</b>
Outlander 800 H.O. EFI XT	2006	_____	<b>631-7152</b>
Outlander Max 800 H.O. EFI	2006	_____	<b>631-7152</b>
Outlander Max 800 H.O. EFI XT	2006	_____	<b>631-7152</b>

## Buell

M2 Cyclone 1200	97-02	_____	<b>631-7171B</b>
		_____	<b>631-7171C</b>
M2 Cyclone 1200 Low	2001	_____	<b>631-7171B</b>
		_____	<b>631-7171C</b>
S1 Lightning 1200	1998	_____	<b>631-7171B</b>
		_____	<b>631-7171C</b>
S1 White Lightning 1200	1998	_____	<b>631-7171B</b>
		_____	<b>631-7171C</b>
S1 White Lightning 1200	2002	_____	<b>631-7171B</b>
		_____	<b>631-7171C</b>
S2 Thunderbolt 1200	94-99	_____	<b>631-7171B</b>
		_____	<b>631-7171C</b>
S2T Thunderbolt 1200	94-99	_____	<b>631-7171B</b>
		_____	<b>631-7171C</b>
S3 Thunderbolt 1200	94-99	_____	<b>631-7171B</b>
		_____	<b>631-7171C</b>
S3T Thunderbolt 1200	94-99	_____	<b>631-7171B</b>
		_____	<b>631-7171C</b>
X1 Lightning 1200	99-02	_____	<b>631-7171B</b>
		_____	<b>631-7171C</b>



# Oil Filters

## Cagiva

Model	Year	Sudco Order No.	K&N Order No.
Alazzurra 350	All	_____	<b>631-7153</b>
Alazzurra 650 GT Sports	82-88	_____	<b>631-7153</b>
Alazzurra Sports 650	82-88	_____	<b>631-7153</b>
Raptor 650	00-04	_____	<b>631-7138</b>
		_____	<b>631-7138C</b>
Raptor 650 i.e.	2005	_____	<b>631-7138</b>
		_____	<b>631-7138C</b>
V Raptor 650	01-04	_____	<b>631-7138</b>
		_____	<b>631-7138C</b>
Elephant 750	89-98	_____	<b>631-7153</b>
Elephant 900	92-97	_____	<b>631-7153</b>
900 Gran Canyon	1999	_____	<b>631-7153</b>
1000 Navigator	00-05	_____	<b>631-7138</b>
		_____	<b>631-7138C</b>
Raptor 1000	00-05	_____	<b>631-7138</b>
		_____	<b>631-7138C</b>
V Raptor 1000	00-04	_____	<b>631-7138</b>
		_____	<b>631-7138C</b>
Xtra Raptor 1000	01-05	_____	<b>631-7138</b>
		_____	<b>631-7138C</b>

## Ducati

350 F3	All	_____	<b>631-7153</b>
350 Indiana	All	_____	<b>631-7153</b>
350 Pantah	All	_____	<b>631-7153</b>
400SS Junior	1992	_____	<b>631-7153</b>
400SS Junior Super Sport	93-94	_____	<b>631-7153</b>
Monster 400	01-03	_____	<b>631-7153</b>
Monster 400 Dark	02-03	_____	<b>631-7153</b>
Monster 400 Dark i.e.	2005	_____	<b>631-7153</b>
Monster 400 i.e.	2005	_____	<b>631-7153</b>
600 SL Pantah Sports	81-85	_____	<b>631-7153</b>
600SS	91-98	_____	<b>631-7153</b>
M600 Monster	93-01	_____	<b>631-7153</b>
620 Sport	2003	_____	<b>631-7153</b>
Monster 620	02-06	_____	<b>631-7153</b>
Monster 620 Dark	03-06	_____	<b>631-7153</b>
Monster 620 Dark MD	2001	_____	<b>631-7153</b>
Monster 620 Dark MD	04-05	_____	<b>631-7153</b>
Monster 620s	02-03	_____	<b>631-7153</b>
Multistrada 620	05-06	_____	<b>631-7153</b>
Multistrada 620 Dark	05-06	_____	<b>631-7153</b>
650 Indiana Custom	86-88	_____	<b>631-7153</b>
748	97-03	_____	<b>631-7153</b>
748 Biposto	95-99	_____	<b>631-7153</b>
748 SP	94-98	_____	<b>631-7153</b>
748 SPS	1999	_____	<b>631-7153</b>
748R	00-02	_____	<b>631-7153</b>
748S	00-02	_____	<b>631-7153</b>
749	04-06	_____	<b>631-7153</b>
749 Dark	05-06	_____	<b>631-7153</b>
749R	04-06	_____	<b>631-7153</b>
749S	03-06	_____	<b>631-7153</b>
750 F1 MKII	85-87	_____	<b>631-7153</b>
750 Indiana Custom	87-88	_____	<b>631-7153</b>
750 Paso	86-90	_____	<b>631-7153</b>
750 Sport	1988	_____	<b>631-7153</b>
750 Sport	1990	_____	<b>631-7153</b>
750 Sport	2002	_____	<b>631-7153</b>
750SS	91-99	_____	<b>631-7153</b>
750SS	01-02	_____	<b>631-7153</b>
750SS i.e.	00-01	_____	<b>631-7153</b>
M750 Monster	96-01	_____	<b>631-7153</b>
Monster750 Dark	99-00	_____	<b>631-7153</b>
Monster750 Dark i.e.	2002	_____	<b>631-7153</b>
Monster750 i.e.	2002	_____	<b>631-7153</b>
800 Sport	2003	_____	<b>631-7153</b>
800SS	03-06	_____	<b>631-7153</b>

## Ducati

Model	Year	Sudco Order No.	K&N Order No.
Monster 800 i.e.	2004	_____	<b>631-7153</b>
Monster 800s i.e.	2003	_____	<b>631-7153</b>
Monster S2R	05-06	_____	<b>631-7153</b>
Monster S2RDark	05-06	_____	<b>631-7153</b>
851 Strada	89-92	_____	<b>631-7153</b>
888 Strada	92-94	_____	<b>631-7153</b>
900 S2	79-85	_____	<b>631-7153</b>
900 Sport	2002	_____	<b>631-7153</b>
900 Superlight	92-97	_____	<b>631-7153</b>
900SS	90-99	_____	<b>631-7153</b>
900SS FE	1998	_____	<b>631-7153</b>
900SS i.e.	00-02	_____	<b>631-7153</b>
MH900e	2001	_____	<b>631-7153</b>
Monster 900	93-01	_____	<b>631-7153</b>
Monster 900 Dark i.e.	2002	_____	<b>631-7153</b>
Monster M900 City	1999	_____	<b>631-7153</b>
Monster M900 Cromo	99-01	_____	<b>631-7153</b>
Monster M900 Dark	2000	_____	<b>631-7153</b>
Monster M900 S	98-00	_____	<b>631-7153</b>
906 Paso Sport	88-91	_____	<b>631-7153</b>
907 i.e.	90-93	_____	<b>631-7153</b>
916 Biposto	93-98	_____	<b>631-7153</b>
916 Senna	96-98	_____	<b>631-7153</b>
916 SP	93-98	_____	<b>631-7153</b>
916 SPS	1993	_____	<b>631-7153</b>
916 SPS Fogarty Replica (Ltd.Ed.)	1999	_____	<b>631-7153</b>
916 Strada	93-98	_____	<b>631-7153</b>
916 Monster S4	01-03	_____	<b>631-7153</b>
916 ST4	99-03	_____	<b>631-7153</b>
944 ST2	97-03	_____	<b>631-7153</b>
992 Monster S2R 1000	2006	_____	<b>631-7153</b>
992 Paul Smart 1000LE	2006	_____	<b>631-7153</b>
992 Sport 1000	2006	_____	<b>631-7153</b>
992 ST3	97-03	_____	<b>631-7153</b>
996	98-01	_____	<b>631-7153</b>
996 Biposto	1999	_____	<b>631-7153</b>
996 SPS	99-00	_____	<b>631-7153</b>
996R	2001	_____	<b>631-7153</b>
996S	00-01	_____	<b>631-7153</b>
996 Monster S4R	03-06	_____	<b>631-7153</b>
996 Monster ST4s	01-05	_____	<b>631-7153</b>
998	02-03	_____	<b>631-7153</b>
998 Matrix	2004	_____	<b>631-7153</b>
998 R	2002	_____	<b>631-7153</b>
998 S	2002	_____	<b>631-7153</b>
999	03-06	_____	<b>631-7153</b>
999R	04-06	_____	<b>631-7153</b>
999S	03-06	_____	<b>631-7153</b>
1000SS	03-06	_____	<b>631-7153</b>
Monster 1000 i.e.	03-05	_____	<b>631-7153</b>
Monster 1000S i.e.	04-05	_____	<b>631-7153</b>
Multistrada 1000 DS	04-06	_____	<b>631-7153</b>
Multistrada 1000s DS	05-06	_____	<b>631-7153</b>

## Gas Gas

EC400 FSE	02-03	_____	<b>631-7112</b>
EC450 FSE	2003	_____	<b>631-7112</b>

**Harley Davidson®**

Model	Year	Sudco Order No.	K&N Order No.
XL53C Sportster Custom	99-03	_____	631-7170
		_____	631-7170C
XL883 Sportster	04-05	_____	631-7171B
		_____	631-7171C
XL883 Sportster Custom	03-05	_____	631-7171B
		_____	631-7171C
XL883 Sportster Low	2005	_____	631-7171B
		_____	631-7171C
XL883R Sportster	02-03	_____	631-7170
		_____	631-7170C
XLH883	80-84	_____	631-7172C
XLH883 Sportster	86-03	_____	631-7170
		_____	631-7170C
XLH883 Sportster Custom	99-02	_____	631-7170
		_____	631-7170C
XLH883 Sportster Deluxe	86-95	_____	631-7170
		_____	631-7170C
XLH883 Sportster Hugster	88-03	_____	631-7170
		_____	631-7170C
XLH883 Sportster Hugster F/I	1987	_____	631-7170
		_____	631-7170C
XLH883R Sportster Flat Track	2000	_____	631-7170
		_____	631-7170C
XL1000 Sportster	84-85	_____	631-7170
		_____	631-7170C
XLH1000 Sportster	1985	_____	631-7171B
		_____	631-7171C
XLS1000 Roadster	80-83	_____	631-7172C
XLX61 Roadster (from late 1984)	84-85	_____	631-7170
		_____	631-7170C
XLX61 Sportster (from late 1984)	84-85	_____	631-7170
		_____	631-7170C
XLH1100 Sportster	86-87	_____	631-7170
		_____	631-7170C
XLH1100 Sportster Liberty	86-87	_____	631-7170
		_____	631-7170C
VRSCA V-Rod	02-06	_____	631-7174C
VRSCB V-Rod	04-05	_____	631-7174C
VRSCD Night Rod	2006	_____	631-7174C
VRSCR Street Rod	2006	_____	631-7174C
XL1200C Sportster Custom	96-03	_____	631-7170
		_____	631-7170C
XL1200C Sportster Custom	04-05	_____	631-7171B
		_____	631-7171C
XL1200R Sportster Roadster	04-05	_____	631-7171B
		_____	631-7171C
XL1200S Sportster Sport	96-03	_____	631-7170
		_____	631-7170C
XLH Sportster Anniversary	1993	_____	631-7170
		_____	631-7170C
XLH1200 Sportster	88-02	_____	631-7170
		_____	631-7170C
XLH1200 Sportster Custom	99-02	_____	631-7170
		_____	631-7170C
VRSCSE Screami Eagle V-Rod	2005	_____	631-7174C
FLH80 Electra Glide	82-84	_____	631-7172C
FLHC Electra Glide Classic	1982	_____	631-7172C
FLHR Electra Glide Road King	96-98	_____	631-7171B
		_____	631-7171C
FLHRI Electra Glide Road King F/I	1996	_____	631-7171B
		_____	631-7171C
FLHS	1984	_____	631-7172C
FLHS Electra Glide Sport	87-93	_____	631-7171B
		_____	631-7171C
FLHS Sport Glide	82-83	_____	631-7172C
FLHT Electra Glide (late 1984)	1984	_____	631-7170
		_____	631-7170C
FLHT Electra Glide	85-89	_____	631-7170
		_____	631-7170C
FLHT Electra Glide Standard	95-98	_____	631-7170
		_____	631-7170C
FLHTC Electra Glide Classic (non US)	84-85	_____	631-7170
		_____	631-7170C

**Harley Davidson®**

Model	Year	Sudco Order No.	K&N Order No.
FLHTC Electra Glide Classic (non US)	1985	_____	631-7171C
FLHTC Electra Glide Classic	86-98	_____	631-7170
		_____	631-7170C
FLHTCI Electra Glide Classic F/I	96-98	_____	631-7170
		_____	631-7170C
FLHTCU Electra Glide Ultra Classic	80-82	_____	631-7170
		_____	631-7170C
FLHTCU Electra Glide Ultra Classic	87-97	_____	631-7170
		_____	631-7170C
FLHTCU Electra Glide Ultra Classic Anniversary	1993	_____	631-7170
		_____	631-7170C
FLHTCUI Ultra Classic Electra Glide F/I	1998	_____	631-7170
		_____	631-7170C
FLST Heritage Softail	87-90	_____	631-7170
		_____	631-7170C
FLSTC Heritage Softail Classic	88-99	_____	631-7170
		_____	631-7170C
FLSTF Fat Boy	90-99	_____	631-7170
		_____	631-7170C
FLSTN Heritage Softail Special	94-98	_____	631-7170
		_____	631-7170C
FLSTS Heritage Springer	97-99	_____	631-7170
		_____	631-7170C
FLT	80-90	_____	631-7170
		_____	631-7170C
FLT80 Tour Glide	80-83	_____	631-7171B
		_____	631-7171C
FLTC Chrome	1988	_____	631-7171B
		_____	631-7171C
FLTC Chrome TT	1987	_____	631-7171B
		_____	631-7171C
FLTC Tour Glide Classic	80-92	_____	631-7170
		_____	631-7170C
FLTC Ultra Tour Glide Anniversary	1993	_____	631-7170
		_____	631-7170C
FLTCU Ultra Tour Glide Classic	87-95	_____	631-7170
		_____	631-7170C
FLTR Road Glide	1998	_____	631-7170
		_____	631-7170C
FLTR Road Glide F/I	1998	_____	631-7170
		_____	631-7170C
FXB Sturgis	1980	_____	631-7173C
FXB Sturgis	1982	_____	631-7173C
FXD Dyna Super Glide	96-98	_____	631-7173C
FXDB Dyna Glide Daytona	1992	_____	631-7173C
FXDB Dyna Glide Sturgis	1991	_____	631-7173C
FXDC Dyna Glide Custom	1992	_____	631-7173C
FXDL Dyna Low Rider	93-98	_____	631-7173C
FXDS Dyna Convertible	96-98	_____	631-7173C
FXDWG Dyna Wide Glide	93-98	_____	631-7173C
FXE Super Glide	82-84	_____	631-7172C
FXEF Super Glide Fat Bob	84-85	_____	631-7172C
FXLR Low Rider Custom	87-94	_____	631-7170
		_____	631-7170C
FXLR Low Rider Custom Anniversary	1993	_____	631-7170
		_____	631-7170C
FXR Super Glide	86-93	_____	631-7170
		_____	631-7170C
FXR Super Glide II	82-83	_____	631-7170
		_____	631-7170C
FXRC Low Glide Custom	1987	_____	631-7170
		_____	631-7170C
FXRD GT	1986	_____	631-7170
		_____	631-7170C
FXRS Low Rider	87-92	_____	631-7170
		_____	631-7170C
FXRS Low Rider Conv.	89-93	_____	631-7170
		_____	631-7170C
FXRS Low Rider Sport	87-88	_____	631-7171B
		_____	631-7171C
FXRS-SP Low Rider Sport	89-93	_____	631-7171B
		_____	631-7171C
FXRT Sport Glide	83-89	_____	631-7170
		_____	631-7170C



# Oil Filters

## Harley Davidson®

Model	Year	Sudco Order No.	K&N Order No.
FXST Softail	84-90	_____	631-7170
		_____	631-7170C
FXST Softail Standard	1999	_____	631-7171B
		_____	631-7171C
FXSTB Night Train	1999	_____	631-7170
		_____	631-7170C
FXSTS Softail Custom	86-99	_____	631-7170
		_____	631-7170C
FXSTS Springer Softail	90-99	_____	631-7170
		_____	631-7170C
FXSTSB Bad Boy	95-97	_____	631-7170
		_____	631-7170C
FXWG Wide Glide	82-86	_____	631-7172C
FLHR Road King	99-06	_____	631-7171B
		_____	631-7171C
FLHRCI Road King Classic F/I	99-06	_____	631-7171B
		_____	631-7171C
FLHRI Electra Glide Road King F/I	00-01	_____	631-7171B
		_____	631-7171C
FLHRI Road King F/I	03-06	_____	631-7171B
		_____	631-7171C
FLHRS Road King Custom	04-06	_____	631-7171B
		_____	631-7171C
FLHRSI Road King Custom F/I	04-06	_____	631-7171B
		_____	631-7171C
FLHT Electra Glide Standard	99-06	_____	631-7171B
		_____	631-7171C
FLHTC Electra Glide Classic	99-05	_____	631-7171B
		_____	631-7171C
FLHTCI Electra Glide Classic F/I	99-06	_____	631-7171B
		_____	631-7171C
FLHTCUI	99-06	_____	631-7171B
Ultra Classic Electra Glide F/I		_____	631-7171C
FLHTI Electra Glide Standard	03-06	_____	631-7171B
		_____	631-7171C
FLHX Street Glide	2006	_____	631-7171B
		_____	631-7171C
FLHXI Street Glide F/I	2006	_____	631-7171B
		_____	631-7171C
FLST Heritage Softail	2006	_____	631-7171B
		_____	631-7171C
FLSTC Heritage Softail Classic	00-06	_____	631-7171B
		_____	631-7171C
FLSTCI Heritage Softail Classic F/I	01-06	_____	631-7171B
		_____	631-7171C
FLSTF Fat Boy	00-06	_____	631-7171B
		_____	631-7171C
FLSTFI Fat Boy F/I	01-06	_____	631-7171B
		_____	631-7171C
FLSTI Heritage Softail F/I	2006	_____	631-7171B
		_____	631-7171C
FLSTN Softail Deluxe	05-06	_____	631-7171B
		_____	631-7171C
FLSTNI Softail Deluxe F/I	05-06	_____	631-7171B
		_____	631-7171C
FLSTS Heritage Springer	00-03	_____	631-7171B
		_____	631-7171C
FLSTSC Softail Springer Classic	05-06	_____	631-7171B
		_____	631-7171C
FLSTSCI Softail Springer Classic F/I	05-06	_____	631-7171B
		_____	631-7171C
FLSTSI Heritage Springer Classic F/I	01-03	_____	631-7171B
		_____	631-7171C
FLTR Road Glide	99-02	_____	631-7171B
		_____	631-7171C
FLTRI Road Glide F/I	99-06	_____	631-7171B
		_____	631-7171C
FXD Dyna Super Glide	99-05	_____	631-7171B
		_____	631-7171C
FXDBI Street Bob F/I	2006	_____	631-7171B
		_____	631-7171C
FXDC Dyna Super Glide Custom	2005	_____	631-7171B
		_____	631-7171C
FXDCI Dyna Super Glide Custom F/I	05-06	_____	631-7171B
		_____	631-7171C

## Harley Davidson®

Model	Year	Sudco Order No.	K&N Order No.
FXDI Dyna Super Glide F/I	04-06	_____	631-7171B
		_____	631-7171C
FXDI35 35th Anniversary Super Glide F/I	2006	_____	631-7171B
		_____	631-7171C
FXDL Dyna Low Rider	99-05	_____	631-7171B
		_____	631-7171C
FXDLI Dyna Low Rider F/I	04-06	_____	631-7171B
		_____	631-7171C
FXDS Dyna Convertible	99-00	_____	631-7171B
		_____	631-7171C
FXDWG Dyna Wide Glide	99-05	_____	631-7171B
		_____	631-7171C
FXDWGI Dyna Wide Glide F/I	04-06	_____	631-7171B
		_____	631-7171C
FXDX Dyna Super Glide Sport	99-04	_____	631-7171B
		_____	631-7171C
FXDXI Dyna Super Glide Sport F/I	04-05	_____	631-7171B
		_____	631-7171C
FXDXT Dyna Super Glide T-Sport	01-03	_____	631-7171B
		_____	631-7171C
FXST Softail Standard	00-06	_____	631-7171B
		_____	631-7171C
FXSTB Night Train	00-06	_____	631-7171B
		_____	631-7171C
FXSTBI Night Train F/I	01-06	_____	631-7171B
		_____	631-7171C
FXSTD Softail Deuce	00-06	_____	631-7171B
		_____	631-7171C
FXSTDI Softail Deuce F/I	01-06	_____	631-7171B
		_____	631-7171C
FXSTI Softail Standard F/I	01-06	_____	631-7171B
		_____	631-7171C
FXSTS Springer Softail	00-06	_____	631-7171B
		_____	631-7171C
FXSTSI Springer Softail F/I	01-06	_____	631-7171B
		_____	631-7171C
FLSTFI Fat Boy F/I 15th Anniv.	2005	_____	631-7171B
		_____	631-7171C
FLTRSEI2 Screamin Eagle Road Glide	2001	_____	631-7171B
		_____	631-7171C
FXSTDSE Screamin Eagle Softail Deuce	03-04	_____	631-7171B
		_____	631-7171C
FLHTCSE Screamin Eagle Electra Glide	03-04	_____	631-7171B
		_____	631-7171C
FLHTCSE2 Screamin Eagle Electra Glide 2	2005	_____	631-7171B
		_____	631-7171C
FLhTFSEI Screamin Eagle Road King F/I	2003	_____	631-7171B
		_____	631-7171C
FLSTFSE Screamin Eagle Fat Boy	2005	_____	631-7171B





**Honda Street**

Model	Year	Sudco Order No.	K&N Order No.
NX250	88-90	_____	631-7112
VTR250 Interceptor	88-90	631-002	631-7111
CB350F Super Sport (4 cylinder)	72-74	631-003	631-7401
CB400A Automatic	1978	631-002	631-7111
CB400F Super Sport	75-77	631-003	631-740
CB400F CB-1	89-90	631-009	631-7303
CB400T1 Hawk I	78-79	631-002	631-7111
CB400T Hawk II	78-79	631-002	631-7111
CB400T Hawk	80-81	631-002	631-7111
CM400A Automatic	79-81	631-002	631-7111
CM400C Custom	1981	631-002	631-7111
CM400E	80-81	631-002	631-7111
CM400T	79-81	631-002	631-7111
CB450SC Nighthawk 450	82-83	631-002	631-7111
CB450SC Nighthawk 450	85-86	631-002	631-7111
CB450T Hawk	1982	631-002	631-7111
CM450A Automatic	82-83	631-002	631-7111
CM450C Custom	1982	631-002	631-7111
CM450E	82-83	631-002	631-7111
CB500K0/K1/K2 (500 Four)	71-73	631-003	631-7401
CX500	78-79	631-002	631-7111
CX500C Custom	79-82	631-002	631-7111
CX500D Deluxe	79-81	631-002	631-7111
CX500TC Turbo	1982	631-002	631-7111
GB500	89-90	_____	631-7112
GL500 Silverwing	81-82	631-002	631-7111
GL500I Silverwing Interstate	81-82	631-002	631-7111
VF500C V30 Magna	84-85	631-005	631-7202
VF500F Interceptor	84-86	631-005	631-7202
VT500C Shadow	83-86	631-005	631-7202
VT500FT Ascot	83-84	631-005	631-7202
CB550F Super Sport	75-77	631-003	631-7401
CB550K0/K1 (550 Four)	74-75	631-003	631-7401
CB550K (550 Four)	76-78	631-003	631-7401
CB550SC Nighthawk	1983	631-003	631-7401
CB600F (599)	04-06	_____	631-7204
CBR600F Hurricane	87-90	631-009	631-7303
CBR600F2 Hurricane	91-94	631-009	631-7303
CBR600F3 Hurricane	95-98	631-009	631-7303
CBR600SE	1998	631-009	631-7303
CBR600SJR	1996	631-009	631-7303
CBR600F4 Hurricane	99-00	631-009	631-7303
CBR600F4i Hurricane	01-06	_____	631-7204
CBR600RR	03-07	_____	631-7204
FSC600 Silverwing	01-02	_____	631-7204
FSC600A Silverwing	03-07	_____	631-7204
FSC600D Silverwing	03-07	_____	631-7204
VT600C Shadow VLX	88-89	631-009	631-7303
VT600C Shadow VLX	91-97	631-009	631-7303
VT600C Shadow	99-07	631-009	631-7303
VT600CD Shadow VLX Deluxe	93-98	631-009	631-7303
VT600CD Shadow Deluxe	99-07	631-009	631-7303
VT600CD2 Shadow Deluxe	99-00	631-009	631-7303
CB650	79-82	631-003	631-7401
CB650C Custom	80-81	631-003	631-7401
CB650SC Nighthawk	82-85	631-003	631-7401
CX650C Custom	1983	631-002	631-7111
CX650T Turbo	1983	631-002	631-7111
GL650 Silverwing	1983	631-002	631-7111
GL650I Silverwing Interstate	1983	631-002	631-7111
NT650 Hawk GT	88-91	631-009	631-7303
NX650	88-89	_____	631-7112
XL600V Transalp	89-90	631-009	631-7303
CB700SC Nighthawk	84-86	631-005	631-7202
VF700C Magna	84-87	631-005	631-7202
VF700F Interceptor	84-85	631-005	631-7202
VF700S Sabre	84-85	631-005	631-7202
VFR700F/F2 Interceptor	86-87	631-005	631-7202
VT700C Shadow	84-87	631-005	631-7202
CB750 Nighthawk 750	91-03	631-009	631-7303
CB750A Automatic	76-78	631-003	631-7401
CB750C Custom	80-82	631-003	631-7401
CB750F Super Sport	75-82	631-003	631-7401
CB750K0/K1/K2/K3/K4/K5	69-75	631-003	631-7401
CB750K	76-82	631-003	631-7401

**Honda Street**

Model	Year	Sudco Order No.	K&N Order No.
CB750L LTD	1979	631-003	631-7401
CB750SC Nighthawk	82-83	631-003	631-7401
RVF750R RC45	1994	_____	631-7204
VF750C Magna	82-83	631-005	631-7202
VF750C Magna	1988	631-005	631-7202
VF750C Magna	94-03	631-009	631-7303
VF750CD Magna Deluxe	95-98	631-009	631-7303
VF750C2 Magna Deluxe	97-00	631-009	631-7303
VF750F Interceptor	83-84	631-005	631-7202
VF750S V45 Sabre	82-83	631-005	631-7202
VFR750F Interceptor	1986	631-005	631-7202
VFR750F	90-97	631-009	631-7303
VFR750R (RC30)	1990	631-009	631-7303
VT750C Shadow	1983	631-005	631-7202
VT750C Shadow A.C.E 750	98-00	631-009	631-7303
VT750CShadow Aero	04-07	_____	631-7204
VT750CA Shadow Aero	04-07	_____	631-7204
VT750CD Shadow Deluxe	98-02	631-009	631-7303
VT750CD2 Shadow Deluxe	98-01	631-009	631-7303
VT750CDA Shadow ACE 750 Deluxe	02-03	631-009	631-7303
VT750CDB Shadow ACE 750 Deluxe	02-03	631-009	631-7303
VT750CDC Shadow ACE 750 Deluxe	02-03	631-009	631-7303
VT750CDD Shadow ACE 750 Deluxe	02-03	631-009	631-7303
VT750DC Shadow Spirit	01-02	631-009	631-7303
VT750DCA Shadow Spirit	03-07	631-009	631-7303
VT750DCB Shadow Spirit	03-07	631-009	631-7303
PC800 Pacific Coast	89-90	631-009	631-7303
PC800 Pacific Coast	94-98	631-009	631-7303
VFR800FI Interceptor	98-01	631-009	631-7303
VFR800 Interceptor	02-07	_____	631-7204
VFR800A Interceptor ABS	02-07	_____	631-7204
VT800C Shadow	1988	631-005	631-7202
CB900C Custom	80-82	631-003	631-7401
CB900F Super Sport	81-82	631-003	631-7401
CB900F (919)	02-07	_____	631-7204
CBR900RR	93-99	631-009	631-7303
CBR929RR	2001	_____	631-7204
CBR929RR	00-01	_____	631-7204
CBR954RR	02-03	_____	631-7204
CB1000	94-95	631-009	631-7303
CB1000C Custom	1983	631-003	631-7401
CBR1000F Hurricane	87-88	631-009	631-7303
CBR1000F Hurricane	90-91	631-009	631-7303
CBR1000F Hurricane	93-96	631-009	631-7303
CBR1000RR	04-07	_____	631-7204
CBX (1047cc six cylinder)	79-82	631-003	631-7401
GL1000 Goldwing	75-79	631-003	631-7401
GL1000L Goldwing LTD	1976	631-003	631-7401
RVT1000R RC51	00-06	_____	631-7204
VF1000F Interceptor	1984	631-005	631-7202
VF1000R	85-86	631-005	631-7202
VTR1000F Super Hawk	98-02	631-009	631-7303
VTR1000F Super Hawk	03-05	_____	631-7204
CB1100F Super Sport	1983	631-003	631-7401
CBR1100XX Blackbird	97-03	631-009	631-7303
GL1100 Goldwing	80-83	631-003	631-7401
GL1100A Goldwing Aspencade	82-83	631-003	631-7401
GL1100I Goldwing Interstate	80-83	631-003	631-7401
ST1100	91-02	631-009	631-7303
ST1100A (ABS)	92-02	631-009	631-7303
VF1100C V65 Magna	83-86	631-005	631-7202
VF1100S V65 Sabre	84-85	631-005	631-7202
VT1100C Shadow 1100	85-88	631-005	631-7202
VT1100C Shadow 1100	89-90	631-009	631-7303
VT1100C Shadow 1100	92-96	631-009	631-7303
VT1100C Shadow 1100 Spirit	1997	631-009	631-7303
VT1100C Shadow Spirit	98-07	631-009	631-7303
VT1100C2 Shadow Sabre	00-07	631-009	631-7303
VT1100C2 Shadow 1100 ACE	95-99	631-009	631-7303
VT1100C2-2 Shadow 1100 ACE	1997	631-009	631-7303
VT1100C3 Shadow Aero	98-02	631-009	631-7303
VT1100D2 Shadow 1100 ACE	1999	631-009	631-7303



# Oil Filters

## Honda Street

Model	Year	Sudco Order No.	K&N Order No.
VT1100T Shadow 1100 ACE Tourer	98-01	631-009	631-7303
GL1200 Goldwing	1984	631-003	631-7401
GL1200A Goldwing Aspencade	84-87	631-003	631-7401
GL1200I Goldwing Interstate	84-87	631-003	631-7401
GL1200L Goldwing LTD	1985	631-003	631-7401
GL1200SEi Goldwing Aspencade	1986	631-003	631-7401
ST1300	03-05	—	631-7204
ST1300A (ABS)	03-05	—	631-7204
VTX1300C	04-07	—	631-7204
VTX1300R	2003	—	631-7204
VTX1300S	05-07	—	631-7204
VTX1300S (Retro 1300)	03-07	—	631-7204
GL1500 Goldwing	88-90	631-009	631-7303
GL1500A Goldwing Aspencade	91-00	631-009	631-7303
GL1500C Valkyrie	97-00	631-009	631-7303
GL1500CD Valkyrie	2003	631-009	631-7303
GL1500CF Valkyrie	01-03	631-009	631-7303
GL1500CF Valkyrie Interstate	99-01	631-009	631-7303
GL1500CT Valkyrie Tourer	97-00	631-009	631-7303
GL1500I Goldwing Interstate	91-96	631-009	631-7303
GL1500SE Goldwing SE	90-00	631-009	631-7303
GL1800 Goldwing	01-06	—	631-7204
GL1800A Goldwing (ABS)	01-06	—	631-7204
NRX1800DA/DB Rune	2004	—	631-7204
NRX1800EA/EB Rune	2004	—	631-7204
VTX1800C	02-04	—	631-7204
VTX1800C1	2005	—	631-7204
VTX1800C2	2005	—	631-7204
VTX1800C3	2005	—	631-7204
VTX1800F1	2005	—	631-7204
VTX1800F2	2005	—	631-7204
VTX1800F3	2005	—	631-7204
VTX1800N1	04-05	—	631-7204
VTX1800N2	04-05	—	631-7204
VTX1800N3	04-05	—	631-7204
VTX1800R (Retro 1800)	02-03	—	631-7204
VTX1800R1	04-05	—	631-7204
VTX1800R2	04-05	—	631-7204
VTX1800R3	04-05	—	631-7204
VTX1800S	02-03	—	631-7204
VTX1800S1	04-05	—	631-7204
VTX1800S2	04-05	—	631-7204
VTX1800S3	04-05	—	631-7204

## Honda ATV

ATC250ES Big Red	85-87	—	631-7112
ATC250SX	85-87	—	631-7112
TRX250 Four Trax 250	85-87	—	631-7112
TRX250X Four Trax 250X	87-88	—	631-7112
TRX250X Four Trax 250X	91-92	—	631-7112
TRX300 Four Trax 300	88-97	—	631-7112
TRX300 Four Trax 300	98-00	—	631-7113
TRX300EX Four Trax 300EX	93-97	—	631-7112
TRX300EX Four Trax 300EX	98-00	—	631-7113
TRX300EX Sportrax 300EX	01-07	—	631-7113
TRX300FW Four Trax 300 4x4	1988	—	631-7112
TRX300FW Four Trax 300 4x4	90-97	—	631-7112
TRX300FW Four Trax 300 4x4	98-00	—	631-7113
ATC350X	85-86	—	631-7112
TRX350 Fourtrax 4x4	86-87	—	631-7112
TRX350D Fourtrax Foreman 4x4	87-89	—	631-7112
TRX350FE Fourtrax Rancher 4x4 ES	00-07	—	631-7113
TRX350FM Fourtrax Rancher 4x4	00-07	—	631-7113
TRX350TE Fourtrax Rancher ES	00-07	—	631-7113
TRX350TM Fourtrax Rancher	00-07	—	631-7113
TRX400FM Fourtrax Foreman	01-03	—	631-7113
TRX400FW Fourtrax Foreman 4x4	95-97	—	631-7112
TRX400FW Fourtrax Foreman 4x4	98-01	—	631-7113
TRX400FW Fourtrax Foreman 4x4	2003	—	631-7113
TRX400EX Fourtrax 400EX	99-00	—	631-7113
TRX400EX Sportrax 400EX	01-07	—	631-7113
TRX450FE Fourtrax Foreman ES	02-03	—	631-7113
TRX450FM Fourtrax Foreman ES	02-03	—	631-7113
TRX450S Fourtrax Foreman S	98-01	—	631-7113

## Honda ATV

Model	Year	Sudco Order No.	K&N Order No.
TRX450ES Fourtrax Foreman ES	98-01	—	631-7113
TRX450R Sportrax 450R	04-09	—	631-7116
TRX500FA Fourtrax Rubicon	01-04	631-002	631-7111
TRX650FA Fourtrax Rubicon	03-05	631-002	631-7111
TRX650FGA Fourtrax Rincon GP	04-05	631-002	631-7111

## Honda Dual Sport & Offroad

XR200R	84-85	—	631-7112
CRF250R	04-09	—	631-7116
CRF250X	04-09	—	631-7116
NX250	88-89	—	631-7112
XL250R	84-87	—	631-7112
XR250L	91-96	—	631-7112
XR250R	84-04	—	631-7112
XL350R	84-85	—	631-7112
XR350R	83-85	—	631-7112
XR400R	96-04	—	631-7112
CRF450R	2002	—	631-7115
CRF450R	03-09	—	631-7116
CRF450X	05-09	—	631-7116
XR500R	83-84	—	631-7112
XL600R	83-87	—	631-7112
XL600V Transalp	89-90	631-009	631-7303
XR600R	85-00	—	631-7112
NX650	88-89	—	631-7112
XR650L	93-07	—	631-7112
XR650R	00-07	—	631-7112

## Husaberg Offroad

All 4-Stroke	95-02	—	631-7155
--------------	-------	---	----------

## Husqvarna Offroad

TC250	02-05	—	631-7154
TE250	02-05	—	631-7154
SM400R	04-05	—	631-7154
TE410E	98-01	—	631-7154
SM450R	04-05	—	631-7154
TC450	02-05	—	631-7154
TE450	02-05	—	631-7154
SM510R	2005	—	631-7154
TC510	2005	—	631-7154
TE510	04-05	—	631-7154
TE510 Centennial	2004	—	631-7154
SM610	98-99	—	631-7154
SM610S	00-01	—	631-7154
TE610E	98-01	—	631-7154
TE610 LT	2000	—	631-7154

## Kawasaki Street

BN125A4/A5 Eliminator 125	01-02	—	631-7112
BN125A7/A8 Eliminator 125	04-05	—	631-7112
BN125A6F/A7F Eliminator 125	06-07	—	631-7112
KZ200A1/A2	78-79	631-602	631-7123
EL250B2/B3 Eliminator	88-89	631-001	631-7401
EL250E1/E2/E3 Eliminator 250HS	91-93	631-001	631-7401
EX250E1/E2 Ninja 250R	86-87	631-001	631-7401
EX250F2/F3/F4 Ninja 250R	88-90	631-001	631-7401
EX250F6-F19 Ninja 250R	92-05	631-001	631-7401
EX250F6F/F7F Ninja 250R	06-07	631-001	631-7401
KZ250D1/D2 LTD&CSR	80-81	631-602	631-7123
KZ250L1 CSR	1982	631-602	631-7123
KZ250W1 LTD	1983	631-602	631-7123
KZ400A1/A2 Deluxe	77-78	631-001	631-7401
KZ400B1/B2	78-79	631-001	631-7401
KZ400C1	1978	631-001	631-7401
KZ400D/D3/D4	74-77	631-001	631-7401
KZ400H1 LTD	1979	631-001	631-7401
KZ400S/S2/S3 Special	75-77	631-001	631-7401
KZ440A1/A2/A3/A4 LTD	80-83	631-001	631-7401
KZ440B1/B2	80-81	631-001	631-7401

## Kawasaki Street

Model	Year	Sudco Order No.	K&N Order No.
KZ440D1/D2/D3/D4/D5 LTD Belt	80-83	631-001	631-7401
KZ440G1 Belt	1982	631-001	631-7401
EN450A1-A6 LTD 454	85-90	631-005	631-7202
EN500A1-A7 Vulcan 500	90-96	631-606	631-7303
EN500C1-C5 Vulcan 500 LTD	96-00	631-606	631-7303
EN500C6-C10 Vulcan 500 LTD	01-05	—	631-7204
EN500C6F/C7F Vulcan 500 LTD	06-07	—	631-7204
EX500A1/A2/A3	87-89	631-005	631-7202
EX500A4/A5/A6/A7	90-93	631-606	631-7303
EX500D1/D2/D3 Ninja 500	94-96	631-606	631-7303
EX500D4-D9 Ninja 500R	97-02	631-606	631-7303
EX500D10/D11/D12 Ninja 500R	03-05	—	631-7204
EX500D6F/D7F Ninja 500R	06-07	—	631-7204
KZ550A1/A2/A3/A4	80-83	631-001	631-7401
KZ550C1/C2/C3/C4 LTD	80-83	631-001	631-7401
KZ550D1 GPz	1981	631-001	631-7401
KZ550F1 Spectre	1983	631-001	631-7401
KZ550F2 LTD	1984	631-001	631-7401
KZ550H1/H2 GPz	82-83	631-001	631-7401
KZ550M1 LTD	1983	631-001	631-7401
ZR550B1/B2/B3/B4 Zephyr	90-93	631-001	631-7401
ZX550A1/A2/A3 GPz	84-86	631-001	631-7401
ZL600A1/A2 Eliminator	86-87	631-001	631-7401
ZL600B2/B3 Eliminator	96-97	631-001	631-7401
ZX600A1/A2/A3 Ninja 600R	85-87	631-001	631-7401
ZX600B1 Ninja 600RX	1987	631-001	631-7401
ZX600C1-C10 Ninja 600R	88-97	631-001	631-7401
ZX600D1/D2/D3/D4 Ninja ZX-6	90-93	631-005	631-7202
ZX600E-E9 Ninja ZX-6	93-01	631-005	631-7202
ZX600E10 Ninja ZX-6	2002	—	631-7204
ZX600E11/E12 ZZR600	03-04	—	631-7204
ZX600F1/F2/F3 Ninja ZX-6R	95-97	631-005	631-7202
ZX600G1/G2 Ninja ZX-6R	98-99	631-005	631-7202
ZX600J1/J2/J3 Ninja ZX-6R	00-02	—	631-7204
ZX600J4 Ninja ZX-6R	2005	—	631-7204
ZX600J6F ZZR600	2006	—	631-7204
ZX600M1/M2 Ninja ZX-6R	04-05	—	631-7204
ZX600N6F Ninja ZX-6R	2006	—	631-7204
ZX636B1/B2 Ninja ZX-6R	03-04	—	631-7204
ZX636C1 Ninja ZX-6R	2005	—	631-7204
ZX636C6F Ninja ZX-6R	2006	—	631-7204
ZX636D6F Ninja ZX-6R	2006	—	631-7204
EJ650A3/A4 W650	00-01	—	631-7204
EX650A6F Ninja 650R	2006	—	631-7204
KZ650B1/B2/B2A/B3	77-79	631-001	631-7401
KZ650C1/C2/C3 Custom	77-79	631-001	631-7401
KZ650D1/D1A/D2 SR	77-78	631-001	631-7401
KZ650E1	1980	631-001	631-7401
KZ650F1	1980	631-001	631-7401
KZ650H1/H2/H3 CSR	81-83	631-001	631-7401
KZ700A1	1984	631-001	631-7401
VN700A1 Vulcan 700	1985	631-005	631-7202
ZN700A1 LTD	84-85	631-001	631-7401
KZ750B1/B2/B3/B4 (2-cyl.)	76-79	631-601	631-7126
KZ750E1/E2/E3	80-82	631-001	631-7401
KZ750F1 LTD	1983	631-001	631-7401
KZ750G1 LTD (2-cyl.)	1980	631-601	631-7126
KZ750H1/H2/H3/H4 LTD	80-83	631-001	631-7401
KZ750K1/K2 LTD 2-cyl.	83-84	631-601	631-7126
KZ750L3	1983	631-001	631-7401
KZ750M1 CSR (2-cyl.)	1982	631-601	631-7126
KZ750N1/N2 Spectre	82-83	631-001	631-7401
KZ750R1 GPz	1982	631-001	631-7401
VN750A2-A10 Vulcan 750	86-94	631-005	631-7202
VN750A11-A14 Vulcan 750	95-98	631-005	631-7202
VN750A15-A19 Vulcan 750	99-03	631-606	631-7303
VN750A20/A21 Vulcan 750	04-05	—	631-7204
VN750A6F Vulcan 750	2006	—	631-7204
ZR750C1/C2/C3 Zephyr	91-93	631-001	631-7401
ZR750F2 ZR-7	2000	631-001	631-7401
ZR750H1/H2/H3 ZR-7S	01-03	631-001	631-7401
ZR750K6F Z750S	2006	—	631-7204
ZX750A1/A2/A3 GPz	83-85	631-001	631-7401
ZX750E1/E2 GPz Turbo	84-85	631-001	631-7401

## Kawasaki Street

Model	Year	Sudco Order No.	K&N Order No.
ZX750F1/F2/F3/F4 Ninja 750R	87-90	631-001	631-7401
ZX750H1 Ninja ZX-7	1989	631-009	631-7303
ZX750H2 Ninja ZX-7	1990	631-001	631-7401
ZX750J1/J2 Ninja ZX-7	91-92	631-009	631-7303
ZX750K1/K2 Ninja ZX-7R	91-92	631-009	631-7303
ZX750L1/L2/L3 Ninja ZX-7	93-95	631-009	631-7303
ZX750M1/M2 Ninja ZX-7R	93-94	631-009	631-7303
ZX750N1/N2 Ninja ZX-7RR	96-97	631-009	631-7303
ZX750P1-P8 Ninja ZX-7R	96-03	631-009	631-7303
VN800A1-A5 Vulcan 800	95-99	631-009	631-7303
VN800A6-A11 Vulcan 800	00-05	—	631-7204
VN800B1-B5 Vulcan 800 Classic	96-00	631-009	631-7303
VN800B6-B10 Vulcan 800 Classic	01-05	—	631-7204
VN800C1/C2 Vulcan 800 Drifter	99-00	631-009	631-7303
VN800E1-E4 Vulcan 800 Drifter	01-04	—	631-7204
VN800E6F Vulcan 800 Drifter	2006	—	631-7204
Z1/A/B-900	73-75	631-601	631-7126
KZ900A4/A5	76-77	631-601	631-7126
KZ900B1 LTD	1976	631-601	631-7126
ZL900A1/A2 Eliminator	85-86	631-001	631-740
ZX900A1/A2/A3 Ninja 900R	84-86	631-001	631-740
ZX900B1/B2/B3/B4 Ninja ZX-9R	94-97	631-009	631-7303
ZX900C1/C2 Ninja ZX-9R	98-99	—	631-7204
ZX900E1/E2 Ninja ZX-9R	00-01	—	631-7204
ZX900F1/F2 Ninja ZX-9R	02-03	—	631-7204
KZ1000A1/A2	77-78	631-601	631-7126
KZ1000A3/A3A/A4 MKII	79-80	631-601	631-7126
KZ1000B1/B2/B3/B4 LTD	77-80	631-601	631-7126
KZ1000C1/C1A/C2/C3/C4 Police	78-81	631-601	631-7126
KZ1000D1 Z1R	1978	631-601	631-7126
KZ1000D3 Z1R	1980	631-601	631-7126
KZ1000E1/E2 Shaft ST	79-80	631-601	631-7126
KZ1000G1 LTD Classic	1980	631-601	631-7126
KZ1000J1/J2/J3	81-83	631-001	631-7401
KZ1000K1/K2 LTD	81-82	631-001	631-7401
KZ1000M1/M2 CSR	81-82	631-001	631-7401
KZ1000P1-P21 Police	82-02	631-001	631-7401
KZ1000P24 Police	2005	631-001	631-7401
KZ1000R1/R2 Replica	82-83	631-001	631-7401
ZG1000A1-A20 Concours	86-05	631-001	631-7401
ZG1000A6F Concours	2006	631-001	631-7401
ZL1000A1 Eliminator	1987	631-001	631-7401
ZR1000A1/A2/A3/A6F Z100	03-06	—	631-7204
ZX1000A1/A2 Ninja 1000R	86-87	631-001	631-7401
ZX1000B1/B2/B3 Ninja ZX-10	88-90	631-001	631-7401
ZX1000C1/C2 Ninja ZX-10R	04-05	—	631-7204
KZ1100A1/A2/A3 Shaft	81-83	631-001	631-7401
KZ1100B1/B2 GPz	81-82	631-001	631-7401
KZ1100D1/D2 Spectre	82-83	631-001	631-7401
KZ1100L1 LTD	1983	631-001	631-7401
ZN1100B1/B2 LTD	84-85	631-001	631-7401
ZR1100A1/A2/A3	92-94	631-001	631-7401
ZR1100C3/C4 ZRX1100	99-00	631-001	631-7401
ZX1100A1/A2 GPz	83-84	631-001	631-7401
ZX1100C1/C2/C3/C4 Ninja ZX-11	90-93	631-001	631-7401
ZX1100D1-D9 Ninja ZX-11	93-01	631-001	631-7401
ZX1100E1/E2/E3 GPz	95-97	631-001	631-7401
ZX1100F1 GPz (ABS)	1996	631-001	631-7401
ZR1200A1/A2/A3/A4/A5 ZRX1200	01-05	631-001	631-7401
ZX1200A1/A2 Ninja ZX-12R	00-01	—	631-7204
ZX1200B1/B2/B3/B4 Ninja ZX-12R	02-05	—	631-7204
ZX1200C1/C2/C3/C4 ZZR1200	02-05	631-001	631-7401
ZG1200A1 Voyager XII	1986	631-001	631-7401
ZG1200B1~B17 Voyager XII	87-03	631-001	631-7401
KZ1300A1/A2/A3/A4	79-82	631-601	631-7126
KZ1300B1 Touring	1980	631-601	631-7126
ZN1300A1-A6 Voyager	83-87	631-601	631-7126
VN1500A1-A7 Vulcan 88	87-93	631-009	631-7303
VN1500A8/A9 Vulcan 88	94-95	631-606	631-7303
VN1500A10/A11/A12 Vulcan 1500	96-98	631-009	631-7303
VN1500B1/B2/B3/B4 Vulcan 88 SE	87-90	631-009	631-7303
VN1500C3/C4 Vulcan 1500 L	96-97	631-009	631-7303
VN1500D1/D2 Vulcan Classi	96-97	631-009	631-7303
VN1500E1 Vulcan 1500 Classi	1998	631-009	631-7303
VN1500E2-E7 Vulcan 1500 Classic	99-04	—	631-7204



# Oil Filters

## Kawasaki Street

Model	Year	Sudco Order No.	K&N Order No.
VN1500G1/G1A-G3 1500 Nomad	99-01	—	<b>631-7204</b>
VN1500J1/J2 Vulcan 1500 Drifter	99-00	—	<b>631-7204</b>
VN1500L1 Vulcan 1500 Nomad Fi	2000	<b>631-009</b>	<b>631-7303</b>
VN1500L2-L5 Vulcan Nomad Fi	01-04	—	<b>631-7204</b>
VN1500N-N3 Vulcan 1500 Classic Fi	00-02	—	<b>631-7204</b>
VN1500N4/N6F Vulcan 1500 Classic	05-06	—	<b>631-7204</b>
VN1500P1/P2 Mean Streak	02-03	—	<b>631-7204</b>
VN1500R1-R5 Vulcan 1500 Drifter	01-05	—	<b>631-7204</b>
VN1600A1-A3 Vulcan 1600 Classic	03-05	—	<b>631-7204</b>
VN1600A6F Vulcan 1600 Classic	2006	—	<b>631-7204</b>
VN1600B1/B2 Vulcan 1600 Mean Streak	04-05	—	<b>631-7204</b>
VN1600D1/D6F Vulcan 1600 Nomad	05-06	—	<b>631-7204</b>
VN1600E6F Vulcan 1600 Classic	2006	—	<b>631-7204</b>
VN1600F6F Vulcan 1600 Mean Streak	2006	—	<b>631-7204</b>
VN2000A1/A2 Vulcan 2000	04-05	—	<b>631-7204</b>

## Kawasaki Personal Watercraft

JT1200B1/B2 Jet Ski STX12F	03-04	—	<b>631-7204</b>
JT1200D1 Jet Ski STX12F	2005	—	<b>631-7204</b>
JT1200D6F Jet Ski STX12F	2006	—	<b>631-7204</b>
JT1500A1/A2/A6F Jet Ski STX15F	04-06	—	<b>631-7204</b>

## Kawasaki ATV

KLT200A1/A2/A3/A4/A4A	81-83	<b>631-602</b>	<b>631-7123</b>
KLT200B1	1983	<b>631-602</b>	<b>631-7123</b>
KLT200C1/C2	83-84	<b>631-602</b>	<b>631-7123</b>
KLF220A1-A15 Bayou 220	88-02	<b>631-602</b>	<b>631-7123</b>
KLF250A1/A2/A3/A6F Bayou 250	03-06	<b>631-602</b>	<b>631-7123</b>
KLT250A1/A2	82-83	<b>631-602</b>	<b>631-7123</b>
KLT250C1/C2/C3 Prairie	83-85	<b>631-602</b>	<b>631-7123</b>
KLT250P1 Police	1984	<b>631-602</b>	<b>631-7123</b>
KSF250A1-A17 Mojave	87-03	<b>631-602</b>	<b>631-7123</b>
KSF250A18 KFX250 Mojave	2004	<b>631-602</b>	<b>631-7123</b>
KEF300A1-A6 Lakota 300	95-00	<b>631-602</b>	<b>631-7123</b>
KEF300B1/B2/B3 Lakota Sport	01-03	<b>631-602</b>	<b>631-7123</b>
KLF300A1/A2 Bayou 300	86-87	<b>631-602</b>	<b>631-7123</b>
KLF300B1-B9 Bayou 300	88-96	<b>631-602</b>	<b>631-7123</b>
KLF300B10-B17 Bayou 300	97-04	<b>631-602</b>	<b>631-7123</b>
KLF300C1-C16 Bayou 300 4x4	89-04	<b>631-602</b>	<b>631-7123</b>
KVF300A1/A2/A3/A4 Prairie 300 4x4	99-02	—	<b>631-7204</b>
KVF300B1/B2/B3/B4 Prairie 300	99-02	—	<b>631-7204</b>
KVF360A1-A6F Prairie 360 4x4	03-06	—	<b>631-7204</b>
KVF360B1/B2/B3/B6F Prairie 360	03-06	—	<b>631-7204</b>
KVF360C1 Prairie 360 4x4	2003	—	<b>631-7204</b>
Advantage Classic			
KVF360C2/C3/C6F Prairie 360 4x4	04-06	—	<b>631-7204</b>
Hardwoods Green HD			
KLF400B1-B7 Bayou 400 4x4	93-99	<b>631-009</b>	<b>631-7303</b>
KSF400A1/A2/A3 KFX400	03-05	—	<b>631-7139</b>
KVF400A1/A2 Prairie 400 4x4	97-98	<b>631-009</b>	<b>631-7303</b>
KVF400B1 Prairie 400	1998	<b>631-009</b>	<b>631-7303</b>
KVF400C1-C4 Prairie 400 4x4	99-02	<b>631-009</b>	<b>631-7303</b>
KVF400D1/D2/D3/D4 Prairie 400	99-02	<b>631-009</b>	<b>631-7303</b>
KVF650A1/A2 Prairie 650 4x4	02-03	—	<b>631-7204</b>
KVF650B1/B2 Prairie 650 4x4	02-03	—	<b>631-7204</b>
Advantage Classic			
KVF650D1/D6F Brute Force 650 4x4	05-06	—	<b>631-7204</b>
KVF650E1 Brute Force 650 4x4	2005	—	<b>631-7204</b>
Realtree Hardwoods Green HD			
KSV700A1/A2/A6F KFX700 V-Force	04-06	—	<b>631-7204</b>
KSV700B1/B2/B6F KFX700 V-Force	04-06	—	<b>631-7204</b>
KSV700C6F KFX700 V-Force	2006	—	<b>631-7204</b>
KVF700A1/A2/A6F Prairie 700 4x4	04-06	—	<b>631-7204</b>
KVF700B1/B2 Prairie 700 4x4	04-05	—	<b>631-7204</b>
Hardwoods Green HD			
KVF700D1/D6F Prairie 700 4x4	05-06	—	<b>631-7204</b>
Team Green Special Edition			
KVF750A1 Brute Force 750 4x4i	2005	—	<b>631-7204</b>
KVF750B1 Brute Force 750 4x4i	2005	—	<b>631-7204</b>
Real Tree Hardwoods Green HD			

## Kawasaki Dual Sport & Offroad

Model	Year	Sudco Order No.	K&N Order No.
KLX110A1/A2/A3/A4/A6F	02-06	—	<b>631-7112</b>
KLX125A1/A2/A3/A6F	03-06	<b>631-403</b>	<b>631-7132</b>
KLX125B1/B2/B3/B6F	03-06	<b>631-403</b>	<b>631-7132</b>
KL250A1/A2/A3/A4/A5	78-82	<b>631-602</b>	<b>631-7123</b>
KL250C1/C2	83-84	<b>631-602</b>	<b>631-7123</b>
KL250D2-D22 KLR250	85-05	<b>631-602</b>	<b>631-7123</b>
KL250G4/G5/G6 Super Sherpa	00-03	—	<b>631-7112</b>
KLX250A1/A2	79-80	<b>631-602</b>	<b>631-7123</b>
KLX250D2/D3/D4	94-96	—	<b>631-7112</b>
KLX250H6F KLX250S Dual Sport	2006	—	<b>631-7112</b>
KX250N1/N2 KX250F	04-05	—	<b>631-7207</b>
KX250T6F KX250F	2006	—	<b>631-7207</b>
KLX300A2-A10 KLX300R	97-05	—	<b>631-7112</b>
KLX300A6F KLX300R	2006	—	<b>631-7112</b>
KLX400A1 KLX400SR Dual Sport	2003	—	<b>631-1739</b>
KLX400B1 KLX400R Offroad	2003	—	<b>631-1739</b>
KX450D6F KX450F	2006	—	<b>631-7112</b>
KL600A1/B1/B2 KLR600	84-86	<b>631-602</b>	<b>631-7123</b>
KL650A1-A19 KLR650	87-05	<b>631-602</b>	<b>631-7123</b>
KL650A6F KLR650	2006	<b>631-602</b>	<b>631-7123</b>
KL650B2/B3 Tengai KLR650	90-91	<b>631-602</b>	<b>631-7123</b>
KLX650A1/A2/A3 Offroad	93-95	<b>631-602</b>	<b>631-7123</b>
KLX650C1/C2/C3/C4 Dual Sport	93-96	<b>631-602</b>	<b>631-7123</b>
KLX650D1 Offroad	93-96	<b>631-602</b>	<b>631-7123</b>

## KTM Dual Sport & Offroad

250 EXC (1st Filter)	02-05	—	<b>631-7155</b>
250 EXC (2nd Filter)	02-05	—	<b>631-7157</b>
400 EGS (1st Filter)	ALL	—	<b>631-7155</b>
400 EGS (2nd Filter)	ALL	—	<b>631-7156</b>
400 EXC (1st Filter)	1999	—	<b>631-7155</b>
400 EXC (2nd Filter)	1999	—	<b>631-7157</b>
400 EXC Racing (1st Filter)	00-02	—	<b>631-7155</b>
400 EXC Racing (2nd Filter)	00-02	—	<b>631-7157</b>
400 EXC (1st Filter)	04-05	—	<b>631-7155</b>
400 EXC (2nd Filter)	04-05	—	<b>631-7157</b>
400 EXE	ALL	—	<b>631-7155</b>
400 LC4 (1st Filter)	98-02	—	<b>631-7155</b>
400 LC4 (2nd Filter)	98-02	—	<b>631-7156</b>
400 MXC (1st Filter)	99-02	—	<b>631-7155</b>
400 MXC (2nd Filter)	99-02	—	<b>631-7157</b>
400 SX (1st Filter)	99-02	—	<b>631-7155</b>
400 SX (2nd Filter)	99-02	—	<b>631-7157</b>
450 EXC Racing (1st Filter)	03-05	—	<b>631-7155</b>
450 EXC Racing (2nd Filter)	03-05	—	<b>631-7157</b>
450 MXC Racing (1st Filter)	03-05	—	<b>631-7155</b>
450 MXC Racing (2nd Filter)	03-05	—	<b>631-7157</b>
450 SMR (1st Filter)	2005	—	<b>631-7155</b>
525 MXC Desert Racing (1st Filter)	03-05	—	<b>631-7155</b>
525 MXC Desert Racing (2nd Filter)	03-05	—	<b>631-7157</b>
525 MXC Racing (1st Filter)	03-05	—	<b>631-7155</b>
525 MXC Racing (2nd Filter)	03-05	—	<b>631-7157</b>
525 SMR (1st Filter)	04-05	—	<b>631-7155</b>
525 SMR (2nd Filter)	04-05	—	<b>631-7157</b>
525 SX Racing (1st Filter)	03-05	—	<b>631-7155</b>
525 SX Racing (2nd Filter)	03-05	—	<b>631-7157</b>
540 SXS (1st Filter)	ALL	—	<b>631-7155</b>
540 SXS (2nd Filter)	ALL	—	<b>631-7157</b>
620 Duke (1st Filter)	1994	—	<b>631-7155</b>
620 Duke (2nd Filter)	1994	—	<b>631-7156</b>
620 Duke (1st Filter)	96-97	—	<b>631-7155</b>
620 Duke (2nd Filter)	96-97	—	<b>631-7156</b>
620 EGS (1st Filter)	ALL	—	<b>631-7155</b>
620 EGS (2nd Filter)	ALL	—	<b>631-7156</b>
620 EXE	ALL	—	<b>631-7155</b>
620 LSK (1st Filter)	ALL	—	<b>631-7155</b>
620 LSK (2nd Filter)	ALL	—	<b>631-7156</b>
625 SMC	04-05	—	<b>631-7155</b>
625 SXC (1st Filter)	02-05	—	<b>631-7155</b>
625 SXC (2nd Filter)	02-05	—	<b>631-7157</b>
640 Duke II (1st Filter)	99-04	—	<b>631-7155</b>
640 Duke II (2nd Filter)	99-04	—	<b>631-7156</b>
640 LC4 (1st Filter)	98-01	—	<b>631-7155</b>
640 LC4 (2nd Filter)	98-01	—	<b>631-7156</b>

### KTM Dual Sport & Offroad

Model	Year	Sudco Order No.	K&N Order No.
640 LC4 Adventure (1st Filter)	2003	_____	<b>631-7155</b>
640 LC4 Adventure (2nd Filter)	2003	_____	<b>631-7156</b>
660 SMC (1st Filter)	02-03	_____	<b>631-7155</b>
660 SMC (2nd Filter)	02-03	_____	<b>631-7157</b>
660 Supermoto (1st Filter)	02-03	_____	<b>631-7155</b>
660 Supermoto (2nd Filter)	02-03	_____	<b>631-7157</b>

### MBK

125 XC Flame	00-03	_____	<b>631-7143</b>
125 XC Flame T	95-96	_____	<b>631-7143</b>
125 XC K Flame R	97-98	_____	<b>631-7143</b>
125 XC Vertex	1997	_____	<b>631-7143</b>

### MZ

500 Red Star	1997	_____	<b>631-7151</b>
500 Saxon Country	91-97	_____	<b>631-7151</b>
500 Saxon Fun	91-93	_____	<b>631-7151</b>
500 Saxon Sport Fun	1993	_____	<b>631-7151</b>
500 Saxon Tour	91-98	_____	<b>631-7151</b>
500 Silver Star	95-96	_____	<b>631-7151</b>
500 Silver Star Classic	91-92	_____	<b>631-7151</b>
500 Silver Star Classic	94-98	_____	<b>631-7151</b>
660 Baghira	98-00	_____	<b>631-7145</b>
660 Mastiff	98-00	_____	<b>631-7145</b>
660 Skorpion	95-01	_____	<b>631-7145</b>
660 Skorpion Cup	1999	_____	<b>631-7145</b>
660 Skorpion Replica	95-99	_____	<b>631-7145</b>
660 Skorpion Sport	94-99	_____	<b>631-7145</b>
660 Skorpion Tour	94-99	_____	<b>631-7145</b>
660 Skorpion Traveller	96-00	_____	<b>631-7145</b>

### Peugeot

125 Elyseo	99-03	_____	<b>631-7185</b>
125 Elystar	03-04	_____	<b>631-7185</b>
125Jet Force	03-04	_____	<b>631-7185</b>
150 Elyseo	01-02	_____	<b>631-7185</b>

### Polaris

Hawkeye 300 2x4	2006	_____	<b>631-7303</b>
		_____	<b>631-7303C</b>
Hawkeye 300 4x4	2006	_____	<b>631-7303</b>
		_____	<b>631-7303C</b>
Magnum 325 2x4	00-02	<b>631-009</b>	<b>631-7303</b>
		_____	<b>631-7303C</b>
Magnum 325 4x4	00-02	<b>631-009</b>	<b>631-7303</b>
		_____	<b>631-7303C</b>
Trail Boss 325 2x4	00-02	<b>631-009</b>	<b>631-7303</b>
		_____	<b>631-7303C</b>
Xpedition 325	00-02	_____	<b>631-7303</b>
		_____	<b>631-7303C</b>
ATP330	04-05	<b>631-009</b>	<b>631-7303</b>
		_____	<b>631-7303C</b>
Magnum 330 2x4	03-05	<b>631-009</b>	<b>631-7303</b>
		_____	<b>631-7303C</b>
Magnum 330 4x4	03-05	<b>631-009</b>	<b>631-7303</b>
		_____	<b>631-7303C</b>
Magnum 330 4x4 Mossy Oak	2004	<b>631-009</b>	<b>631-7303</b>
		_____	<b>631-7303C</b>
Trail Boss 330	03-06	<b>631-009</b>	<b>631-7303</b>
		_____	<b>631-7303C</b>
Sportsman 335	99-01	_____	<b>631-7303</b>
		_____	<b>631-7303C</b>
Sportsman 400 2x4	2001	_____	<b>631-7303</b>
		_____	<b>631-7303C</b>
Sportsman 400 4x4	01-05	_____	<b>631-7303</b>
		_____	<b>631-7303C</b>
Xplorer 400L	96-0	_____	<b>631-7303</b>
		_____	<b>631-7303C</b>
Magnum 425 2x4	96-98	_____	<b>631-7303</b>
		_____	<b>631-7303C</b>
Magnum 425 4x4	95-98	<b>631-009</b>	<b>631-7303</b>
		_____	<b>631-7303C</b>

### Polaris

Model	Year	Sudco Order No.	K&N Order No.
Magnum 425 6x6	96-97	<b>631-009</b>	<b>631-7303</b>
		_____	<b>631-7303C</b>
Ranger 425 2x4	2001	<b>631-009</b>	<b>631-7303</b>
		_____	<b>631-7303C</b>
Ranger 425 2x4	2003	<b>631-009</b>	<b>631-7303</b>
		_____	<b>631-7303C</b>
Xpedition 425	00-02	_____	<b>631-7303</b>
		_____	<b>631-7303C</b>
Sportsman 450	2006	_____	<b>631-7303</b>
		_____	<b>631-7303C</b>
Diesel 455 4x4	99-01	_____	<b>631-7303</b>
		_____	<b>631-7303C</b>
ATP500 H0	04-05	_____	<b>631-7303</b>
		_____	<b>631-7303C</b>
Big Boss 500 6x6	98-99	<b>631-009</b>	<b>631-7303</b>
		_____	<b>631-7303C</b>
Magnum 500 4x4	99-03	<b>631-009</b>	<b>631-7303</b>
		_____	<b>631-7303C</b>
Predator 500	03-06	_____	<b>631-7112</b>
Predator 500 TLD	2006	_____	<b>631-7112</b>
Predator 500 Troy Lee Edition	2006	_____	<b>631-7112</b>
Ranger 500 2x4	04-06	<b>631-009</b>	<b>631-7303</b>
		_____	<b>631-7303C</b>
Ranger500 4x4	03-06	<b>631-009</b>	<b>631-7303</b>
		_____	<b>631-7303C</b>
Scrambler 500 4x4	96-06	<b>631-009</b>	<b>631-7303</b>
		_____	<b>631-7303C</b>
Sportsman 500	96-02	<b>631-009</b>	<b>631-7303</b>
		_____	<b>631-7303C</b>
Sportsman 500 6x6	00-06	_____	<b>631-7303</b>
		_____	<b>631-7303C</b>
Sportsman 500 EFI	2006	_____	<b>631-7303</b>
		_____	<b>631-7303C</b>
Sportsman 500 H.O	04-06	_____	<b>631-7303</b>
		_____	<b>631-7303C</b>
Sportsman 500 H.O.4x4	02-03	_____	<b>631-7303</b>
		_____	<b>631-7303C</b>
Sportsman 500 H.O. Mossy Oak	2004	_____	<b>631-7303</b>
		_____	<b>631-7303C</b>
Xplorer 500 4x4	1997	_____	<b>631-7303</b>
		_____	<b>631-7303C</b>
Sportsman 600 4x4	2003	_____	<b>631-7196</b>
Sportsman 600 Twin	2004	_____	<b>631-7196</b>
Sportsman 700 4x4	02-03	_____	<b>631-7196</b>
Sportsman 700 Twin	2004	_____	<b>631-7196</b>
Sportsman 700 Twin EFI	2004	_____	<b>631-7196</b>
Sportsman 700 Twin Mossy Oak	2004	_____	<b>631-7196</b>

### Sachs

125 Roadster	98-01	_____	<b>631-7145</b>
--------------	-------	-------	-----------------

### Suzuki Street

GN125Z/D	82-83	<b>631-402</b>	<b>631-7131</b>
GN125EM/EN/EP/ER/ES/ET/EV	91-97	<b>631-402</b>	<b>631-7131</b>
GN250Z/D	82-83	<b>631-409</b>	<b>631-7136</b>
GN250F	1985	<b>631-409</b>	<b>631-7136</b>
GN250J	1988	<b>631-409</b>	<b>631-7136</b>
GS250TT/TX	80-81	<b>631-401.5</b>	<b>631-7133</b>
GZ250X/YK1-K5 Marauder	99-05	<b>631-409</b>	<b>631-7136</b>
GS300LZ/LD	82-83	<b>631-401.5</b>	<b>631-7133</b>
GS300LF	1985	<b>631-401.5</b>	<b>631-7133</b>
AN400K3/K4/K5/K6 Burgman	03-06	<b>631-403</b>	<b>631-7132</b>
GN400T/XT/XX/TX/TZ	80-82	_____	<b>631-7136</b>
GS400B/XB/C/XC	77-78	<b>631-401.5</b>	<b>631-7133</b>
GSF400M/N/P Bandit	91-93	<b>631-401.5</b>	<b>631-7133</b>
GS425N/EN	1979	<b>631-401.5</b>	<b>631-7133</b>
GS425LN	1979	<b>631-401.5</b>	<b>631-7133</b>
GS450ET/EX/EZ/ED	80-83	<b>631-401.5</b>	<b>631-7133</b>
GS450GAZ/GAD Automatic	82-83	<b>631-401.5</b>	<b>631-7133</b>
GS450GAF Automatic	1985	<b>631-401.5</b>	<b>631-7133</b>
GS450LT/LX/LZ/LD	80-83	<b>631-401.5</b>	<b>631-7133</b>
GS450LF/LG/LH/LJ	85-88	<b>631-401.5</b>	<b>631-7133</b>

## Suzuki Street

Model	Year	Sudco Order No.	K&N Order No.
GS450ST/SX	81-82	<b>631-401.5</b>	<b>631-7133</b>
GS450TX/TZ/TXZ/TXD	81-83	<b>631-401.5</b>	<b>631-7133</b>
GS500EK-EY	89-00	<b>631-401.5</b>	<b>631-7133</b>
GS500EK1/EK2	01-02	<b>631-401.5</b>	<b>631-7133</b>
GS500FK4/FK5/FK6	04-06	<b>631-401.5</b>	<b>631-7133</b>
GS550B/C/EC/N/EN	77-79	<b>631-401.5</b>	<b>631-7133</b>
GS550ET	1980	<b>631-401.5</b>	<b>631-7133</b>
GS550ED/ESD	1983	<b>631-401.5</b>	<b>631-7133</b>
GS550ES3/ESE/EF/ESF/ESG	83-86	<b>631-401.5</b>	<b>631-7133</b>
GS550LN/LT/LX/LZ/LD	79-83	<b>631-401.5</b>	<b>631-7133</b>
GS550LF/LG	85-86	<b>631-401.5</b>	<b>631-7133</b>
GS550MD Katana	1982	<b>631-401.5</b>	<b>631-7133</b>
GS550TX	1981	<b>631-401.5</b>	<b>631-7133</b>
GSF600ST/SV/SW/SX/SY Bandit	96-00	<b>631-405</b>	<b>631-7138</b>
GSF600SSK1/SK2/SK3 Bandit	01-03	<b>631-405</b>	<b>631-7138</b>
GSX600FJ-FY Katana	88-00	<b>631-405</b>	<b>631-7138</b>
GSX600FK1/FK2/FK3 Katana	98-03	<b>631-405</b>	<b>631-7138</b>
GSX-R600WN/WP	92-93	<b>631-405</b>	<b>631-7138</b>
GSX-R600V/W/X/Y/K1/K2/K3	97-03	<b>631-405</b>	<b>631-7138</b>
RF600RR/RS/RT	94-96	<b>631-405</b>	<b>631-7138</b>
AN650K3/K4/K5 Burgman	03-05	<b>631-405</b>	<b>631-7138</b>
GR650D/XD Tempter	1983	<b>631-401.5</b>	<b>631-7133</b>
GS650EX/EZ	81-82	<b>631-401.5</b>	<b>631-7133</b>
GS650GX/GZ/GD	81-83	<b>631-401.5</b>	<b>631-7133</b>
GS650GLX/GLZ/GLD	81-83	<b>631-401.5</b>	<b>631-7133</b>
GS650MD Katana	1983	<b>631-401.5</b>	<b>631-7133</b>
LS650PG/PH/PJ Savage	86-88	<b>631-408</b>	<b>631-7137</b>
LS650PS/PT/PV/PW/PX/PY Savage	95-00	<b>631-408</b>	<b>631-7137</b>
LS650PK1/PK2/PK3/PK4 Savage	01-04	<b>631-408</b>	<b>631-7137</b>
SV650X/Y/K1/K2/K3/K4/K5	99-05	<b>631-405</b>	<b>631-7138</b>
SV650SX/SY/SK1/SK2/SK3/SK4/SK5	99-05	<b>631-405</b>	<b>631-7138</b>
XN85 Turbo	1983	<b>631-401.5</b>	<b>631-7133</b>
GS700EF/ESF	1985	<b>631-401.5</b>	<b>631-7133</b>
GV700GLF/GLF2 Madura	1985	<b>631-404</b>	<b>631-7134</b>
VS700GLFG	1986	<b>631-404</b>	<b>631-7134</b>
VS700GLFH Intruder	1987	<b>631-405</b>	<b>631-7138</b>
VS700GLPG	1986	<b>631-404</b>	<b>631-7134</b>
VS700GLPH Intruder	1987	<b>631-405</b>	<b>631-7138</b>
VS700GLEFG	1986	<b>631-404</b>	<b>631-7134</b>
VS700GLEFH	1987	<b>631-405</b>	<b>631-7138</b>
VS700GLEPG Intruder	1986	<b>631-404</b>	<b>631-7134</b>
VS700GLEPH Intruder	1987	<b>631-405</b>	<b>631-7138</b>
GS750B/C/EC/N/EN	77-79	<b>631-401.5</b>	<b>631-7133</b>
GS750ET/EX/EZ	80-82	<b>631-401.5</b>	<b>631-7133</b>
GS750ED/ESD	1983	<b>631-401.5</b>	<b>631-7133</b>
GS750LN	1979	<b>631-401.5</b>	<b>631-7133</b>
GS750LT/LX	80-81	<b>631-401.5</b>	<b>631-7133</b>
GS750SD Katana	1983	<b>631-401.5</b>	<b>631-7133</b>
GS750TZ/TD	82-83	<b>631-401.5</b>	<b>631-7133</b>
GSX750FK-FY Katana	89-00	<b>631-405</b>	<b>631-7138</b>
GSX750FK1/FK2/FK3 Katana	01-03	<b>631-405</b>	<b>631-7138</b>
GSX-R750G/H	86-87	<b>631-404</b>	<b>631-7134</b>
GSX-R750RG	1986	<b>631-404</b>	<b>631-7134</b>
GSX-R750J/K/L/M/N	88-92	<b>631-405</b>	<b>631-7138</b>
GSX-R750WP/WR/WS	93-95	<b>631-405</b>	<b>631-7138</b>
GSX-R750TV/W/WX/Y/K1/K2/K3	96-03	<b>631-405</b>	<b>631-7138</b>
VS750GLPJ-GLPM Intruder	88-91	<b>631-405</b>	<b>631-7138</b>
VL800K1/K2/K3 Intruder Volusia	01-03	<b>631-405</b>	<b>631-7138</b>
VS800GLN-GLY Intruder	92-00	<b>631-405</b>	<b>631-7138</b>
VS800GLK1/GLK2/GLK3 Intruder	01-03	<b>631-405</b>	<b>631-7138</b>
VX800L/M/N/P	90-93	<b>631-405</b>	<b>631-7138</b>
VZ800V/W/X/Y/K1/K2/K3 Marauder	97-03	<b>631-405</b>	<b>631-7138</b>
GS850GN/GT/GX/GZ/GD	79-83	<b>631-401.5</b>	<b>631-7133</b>
GS850GLT/GLX/GLZ/GLD	80-83	<b>631-401.5</b>	<b>631-7133</b>
RF900RR/RS/RT/RV	94-97	<b>631-405</b>	<b>631-7138</b>
RF900RZS	1995	<b>631-405</b>	<b>631-7138</b>
DL1000K2/K3/K4/K5 V-Storm	02-05	<b>631-405</b>	<b>631-7138</b>
GS1000C/EC/N/EN/ET	78-80	<b>631-401.5</b>	<b>631-7133</b>
GS1000GT/GLT/GX/GLX	80-81	<b>631-401.5</b>	<b>631-7133</b>
GS1000LN	1979	<b>631-401.5</b>	<b>631-7133</b>
GS1000SN/ST	79-80	<b>631-401.5</b>	<b>631-7133</b>
GS1000SZ Katana	1982	<b>631-401.5</b>	<b>631-7133</b>
GSX-R1000K1/K2/K3/K4	01-04	<b>631-405</b>	<b>631-7138</b>
SV1000SK3/SK4	03-04	<b>631-405</b>	<b>631-7138</b>
TL1000RW/RX/RX/RK1/RK2/RK3	98-03	<b>631-405</b>	<b>631-7138</b>

## Suzuki Street

Model	Year	Sudco Order No.	K&N Order No.
TL1000RK4	04	<b>631-405</b>	<b>631-7138</b>
TL1000SV/SW/SX/SY/SK1	97-01	<b>631-405</b>	<b>631-7138</b>
GS1100ET/EX/EZ/ED/ESD	80-83	<b>631-401.5</b>	<b>631-7133</b>
GS1100GKZ/GK2/GKD/GKE Shaft	82-84	<b>631-401.5</b>	<b>631-7133</b>
GS1100GZ/GLZ/GD/GLD	82-83	<b>631-401.5</b>	<b>631-7133</b>
GS1100LT	1980	<b>631-401.5</b>	<b>631-7133</b>
GS1100SDKatana	1983	<b>631-401.5</b>	<b>631-7133</b>
GSX1100FJ/FK/FL/FM/FN/FP Katana	88-93	<b>631-405</b>	<b>631-7138</b>
GSX1100GM/GN/GP Shaft	91-93	<b>631-405</b>	<b>631-7138</b>
GSX-R1100G/H/J/K/L/M/N	86-92	<b>631-405</b>	<b>631-7138</b>
GSX-R1100WP/WR/WS/WT/WW/WWW	93-98	<b>631-405</b>	<b>631-7138</b>
GS1150ES3/ESE/EF/ESF/EF2	83-85	<b>631-401.5</b>	<b>631-7133</b>
GS1150EG/ESG	83-86	<b>631-401.5</b>	<b>631-7133</b>
GSF1200SV/SW/SX/SY Bandit	97-00	<b>631-405</b>	<b>631-7138</b>
GSF1200SK1-SK5 Bandit	01-05	<b>631-405</b>	<b>631-7138</b>
GSF1200SAV Bandit	1997	<b>631-405</b>	<b>631-7138</b>
GSX1300RX/RX/RK1 Hayabusa	99-01	<b>631-405</b>	<b>631-7138</b>
GSX1300RK2/-RK5 Hayabusa	02-05	<b>631-405</b>	<b>631-7138</b>
GV1200GLF/GLF2/GLG Madura	85-86	<b>631-404</b>	<b>631-7134</b>
GV1400GCG Cavalcade	1986	<b>631-404</b>	<b>631-7134</b>
GV1400GCH Cavalcade	1987	<b>631-405</b>	<b>631-7138</b>
GV1400GDG Cavalcade	1986	<b>631-404</b>	<b>631-7134</b>
GV1400GDH/GDJ Cavalcade	87-88	<b>631-405</b>	<b>631-7138</b>
GV1400GTG Cavalcade	1986	<b>631-404</b>	<b>631-7134</b>
GV1400GTH Cavalcade	1987	<b>631-405</b>	<b>631-7138</b>
			<b>631-7138C</b>
VS1400GLFH Intruder	1987	<b>631-405</b>	<b>631-7138</b>
VS1400GLPH/GLPJ Intruder	87-88	<b>631-405</b>	<b>631-7138</b>
VS1400GLPM-GLPY Intruder	90-00	<b>631-405</b>	<b>631-7138</b>
VS1400GLPK1-GLPK3 Intruder	01-03	<b>631-405</b>	<b>631-7138</b>
VL1500W/X/Y/K1/K2/K3 Intruder LC	98-03	<b>631-405</b>	<b>631-7138</b>
			<b>631-7138C</b>

## Suzuki ATV

LT160EK/EL/EM/EN Quad	89-92	<b>631-403</b>	<b>631-7132</b>
LT160K3/K4 Quadrunner	03-04	<b>631-403</b>	<b>631-7132</b>
LT-F160M/N/P/R/S/T/V/W/X/Y	91-00	<b>631-403</b>	<b>631-7132</b>
LT-F160	91-01	<b>631-403</b>	<b>631-7132</b>
ALT185F	1985	<b>631-402</b>	<b>631-7131</b>
LT185E/F/G/H	84-87	<b>631-402</b>	<b>631-7131</b>
LT230EH-EP Quadrunner	87-93	<b>631-403</b>	<b>631-7132</b>
LT230GEF/GEG Quadrunner	85-86	<b>631-403</b>	<b>631-7132</b>
LT230SF/SG/SH/SJ QuadSport	85-88	<b>631-403</b>	<b>631-7132</b>
LT-F230G/H	86-87	<b>631-403</b>	<b>631-7132</b>
LT250EF/FFF/EFG Quadrunner	85-86	<b>631-403</b>	<b>631-7132</b>
LT250SK/SL	89-90	<b>631-403</b>	<b>631-7132</b>
LT-F250J/K/L/M/N/P/R/S/T/V/W/X	88-99	<b>631-403</b>	<b>631-7132</b>
LT-F250FK2/FK3/FK4/FK5 Ozark	02-05	<b>631-403</b>	<b>631-7132</b>
LT-F250FX/FY/FK1/FK2 Quad	99-02	<b>631-403</b>	<b>631-7132</b>
LT-Z250K4/K5 QuadSport	04-05	<b>631-403</b>	<b>631-7132</b>
LT300EH/EJ/EK	87-89	<b>631-403</b>	<b>631-7132</b>
LT-F300FX/FY/FK1/FK2 King Quad	99-02	<b>631-403</b>	<b>631-7132</b>
LT-4WDH/J/K/L/M/N 4WD Quad	87-92	<b>631-403</b>	<b>631-7132</b>
LT-4WDP/R/S/T 4WD King Quad	93-96	<b>631-403</b>	<b>631-7132</b>
LT-F4WDXM/N/P/R/S King Quad	92-96	<b>631-403</b>	<b>631-7132</b>
LT-F4WDXT/V/W King Quad	97-99	<b>631-403</b>	<b>631-7132</b>
LT-A400K2 Eiger 2WD Auto	2002	<b>631-405</b>	<b>631-7138</b>
LT-A400K3/K4 Eiger 2WD Auto	03-04	<b>631-405</b>	<b>631-7138</b>
LT-A400FK2 Eiger 4WD	2002	<b>631-405</b>	<b>631-7138</b>
LT-A400FK3/FK4 Eiger Auto 4WD	03-04	<b>631-405</b>	<b>631-7138</b>
LT-F400K2 Eiger 2WD	2002	<b>631-405</b>	<b>631-7138</b>
LT-F400K3/K4 Eiger 2WD	03-04	<b>631-405</b>	<b>631-7138</b>
LT-F400FK2/FK3/FK4 Eiger 4WD	02-04	<b>631-405</b>	<b>631-7138</b>
LT-Z400K3/K4/K5 QuadSport 400	03-05		<b>631-7139</b>
LT-A500FY/FK1	00-01	<b>631-405</b>	<b>631-7138</b>
LT-A500FK2/FK3/FK4 Vinson 4WD	02-04	<b>631-405</b>	<b>631-7138</b>
LT-F500FW-FK3 Quadrunner	98-02	<b>631-405</b>	<b>631-7138</b>
LT-F500FK3 Vinson Manual 4WD	2003	<b>631-405</b>	<b>631-7138</b>
LT-F500FK4 Vinson Manual 4WD	2004	<b>631-405</b>	<b>631-7138</b>
LTA700 King Quad 4x4	05-06	<b>631-405</b>	<b>631-7138</b>

**Suzuki Dual Sport & Offroad**

Model	Year	Sudco Order No.	K&N Order No.
DR100D/E/F/G/H/J/K/L	83-90	631-402	631-7131
SP100D	1983	631-402	631-7131
DR-Z110K3/K4/K5	03-05	————	631-7112
DR125Z/D/E	82-84	631-402	631-7131
DR125G/H/J	86-88	631-403	631-7132
DR125SER/SES/SET Dual Sport	94-96	631-403	631-7132
DR-Z125K3/K4/K5 Offroad	03-05	631-403	631-7132
DR-Z125LK3/LK4/LK5 Offroad	03-05	631-403	631-7132
SP125G/H/J Dual Sport	86-88	631-403	631-7132
DR200G/H/J	86-88	631-403	631-7132
DR200SET-SEY Dual Sport	96-00	631-403	631-7132
DR200SEK1-SEK5 Dual Sport	01-05	631-403	631-7132
SP200G/H/J Dual Sport	86-88	631-403	631-7132
DR250Z/D Offroad	82-83	631-409	631-7136
DR250F Offroad	1985	631-409	631-7136
DR250L/M/N/P Offroad	90-93	631-409	631-7136
DR250SL-SES Dual Sport	90-95	631-409	631-7136
DR-Z250K1/K2/K3/K4/K5	01-05	631-409	631-7136
SP250Z/D Dual Sport	82-83	631-409	631-7136
SP250F Dual Sport	1985	631-409	631-7136
RM-Z250K4/K5	04-05	————	631-7207
DR350L/M/N/P/R/S/T/V/W/X Offroad	90-99	631-409	631-7136
DR350SL-SEX Dual Sport	90-99	631-409	631-7136
DR370C/N	78-79	————	————
SP370C/N	78-79	————	————
DR-Z400Y/K1/K2/K3/K4 Offroad	00-04	————	631-7139
DR-Z400EY/EK1/EK2/EK3/EK4	00-04	————	631-7139
Offroad Electric Start			
DR-Z400SY/SK1/SK2/SK3/SK4 Dual	00-04	————	631-7139
SP400T	1980	————	————
RM-Z450K5	2005	————	————
DR500X/Z/D	81-83	631-408	631-7137
SP500X/Z/D Dual Sport	81-83	631-408	631-7137
SP600F Dual Sport	1984	631-408	631-7137
DR650SL-SEY Dual Sport	90-00	631-408	631-7137
DR650SK1-SK5 Dual Sport	01-05	631-408	631-7137

**Triumph**

Daytona 600	2004	————	631-7191
Speed Four	03-05	————	631-7191
TT600	00-03	————	631-7191
Daytona 650	2005	————	631-7191
Daytona 750	91-95	————	631-7192
Speed Triple 750	1997	————	631-7192
Thunderbird 750	1995	————	631-7192
Trident 750	92-98	————	631-7192
America 800	03-06	————	631-7191
Bonneville 800	01-05	————	631-7191
Bonneville America	2002	————	631-7191
Bonneville T100	02-04	————	631-7191
Speedmaster 800	03-04	————	631-7191
Speed Triple T509	97-98	————	631-7191
Adventurer 900	95-01	————	631-7192
Bonneville T100	05-06	————	631-7191
Daytona 900	94-97	————	631-7192
Daytona 900 Super III	94-97	————	631-7192
Legend 900 TT	99-01	————	631-7192
Speed Triple 900	94-96	————	631-7192
Speedmaster 900	05-06	————	631-7191
Sprint 900	95-98	————	631-7192
Thruxton 900	04-06	————	631-7191
Thunderbird 900	95-03	————	631-7192
Thunderbird Sport 900	95-03	————	631-7192
Thundebolt 900	1996	————	631-7192
Tiger 900	91-00	————	631-7192
Trident 900	91-98	————	631-7192

**Triumph**

Model	Year	Sudco Order No.	K&N Order No.
Trophy 900	91-01	————	631-7192
Daytona 955i (EFI)	99-06	————	631-7191
Daytona T595	97-98	————	631-7191
Speed Triple 955	99-04	————	631-7191
Sprint RS 955	01-03	————	631-7191
Sprint ST 955	01-04	————	631-7191
Tiger 955cc	01-06	————	631-7191
Daytona 1000	91-95	————	631-7192
Speed Triple 1050	05-06	————	631-7191
Sprint ST 1050	05-06	————	631-7191
Daytona 1200	93-97	————	631-7192
Trophy 1200	91-03	————	631-7192
Rocket III 2294	04-06	————	631-7191
Rocket III Classic 2294	04-06	————	631-7191

**Yamaha Street**

XT125J/K/KC Dual Sport	82-83	631-204	631-7143
XC180K/KC/L/LC/N/NC Riva 180	83-85	631-203	631-7145
XC180ZL/ZLC/ZN/ZNC Riva 180	84-85	631-203	631-7145
SR185H/J	81-82	631-204	631-7143
TW200T/TC-V/VC Trailway	87-06	631-204	631-7143
XC200U/W/A/B Riva 200 (Scooter)	88-91	631-203	631-7145
XC200ZU/ZW/ZA Riva 200Z	88-90	631-203	631-7145
XT200J/K/KC Dual Sport	82-83	631-204	631-7143
XT225D/DC-V/VC Serrow	92-03	631-204	631-7143
SR250G/H/J Exciter	80-82	631-203	631-7145
SR250TH Exciter	80-82	631-203	631-7145
SRX250T/TC	1987	631-204	631-7143
XT250G/H/J/K/KC Dual Sport	80-83	631-203	631-7145
XT250L/LC Dual Sport	1984	631-204	631-7143
XV250U/UC/W/WC/A/AC Route 66	88-90	631-203	631-7145
XV250G/GC-K/KC Route 66	95-98	631-203	631-7145
XV250L/LC Virago	1999	631-203	631-7145
XV250P/PC/R/S/SC/T/TC Virago 250	02-05	631-203	631-7145
XV250V/V/C Virago 250	2006	631-203	631-7145
XT350N/NC-M/MC Dual Sport	85-00	631-204	631-7143
XS360C/D/2D	76-77	631-201	631-7144
FZR400U/SUC/W/SWC/A/SAC	88-90	631-201	631-7144
YP400T/V Majesty (Scooter)	05-06	631-403	631-7132
XS400D/E/F/G/H	77-81	631-201	631-7144
XS400E/2F	78-79	631-201	631-7144
XS400J/K Maxim	82-83	631-201	631-7144
XS400R/RK Seca	82-83	631-201	631-7144
XS400SG/SH/SJ Special	80-82	631-201	631-7144
SR500E/F/G/H	78-81	631-203	631-7145
XT500C/D/E/F/G/H Dual Sport	76-81	631-203	631-7145
XV500K Virago	1983	631-203	631-7145
XV535T/TC/U Virago	87-88	631-203	631-7145
XV535A/AC Virago	1990	631-203	631-7145
XV535E/EC-M/MC Virago	93-00	631-203	631-7145
XV535SF/SFC/SG/SGC Virago	94-95	631-203	631-7145
XV535SH/SHC/SJ/SJC Virago	96-97	631-203	631-7145
XJ550H/J/K Maxim	81-83	631-201	631-7144
XJ550RH/RJ/RK Seca	81-83	631-201	631-7144
XT550J/K Dual Sport	82-83	631-203	631-7145
XZ550R/RK Vision	82-83	631-203	631-7145
FJ600L/LC/N/NC	84-85	631-201	631-7144
FZ600S/SC/T/TC/U/UC	86-88	631-201	631-7144
FZ600SS/SSC/T/TC FZ6	04-05	631-009	631-7303
FZR600W/WC/AC	89-90	631-201	631-7144
FZR600RA/RAC	1990	631-201	631-7144
FZR600RB/RBC-RL/RLC	91-99	631-009	631-7303
SRX600S/SC	1986	631-203	631-7145
XJ600SD/SDC-SK/SKC Seca II	92-98	631-009	631-7303
XT600L/LC-EG/EGC Dual Sport	84-95	631-203	631-7145
YX600S/SC-A/AC Radian	86-90	631-201	631-7144



## Yamaha Street

Model	Year	Sudco Order No.	K&N Order No.
YZF600RG/RGC-RV/RVC	95-06	631-009	631-7303
YZF-R6/LC-T/TC	99-05	631-009	631-7303
YZF-R6SV/SVC	2006	631-009	631-7303
XJ650G/H/J/K Maxim	80-83	631-201	631-7144
XJ650LH Midnight Maxim	1981	631-201	631-7144
XJ650LJ/LK Seca Turbo	82-83	631-201	631-7144
XJ650RJ Seca	1982	631-201	631-7144
XVS650AK/AKC-AV/AVC	98-06	631-203	631-7145
V-Star Classic			
XVS650ATR/ATRC/ATS/ATSC	03-04	631-203	631-7145
V-Star Silverado			
XVS650ATT/ATTC/ATVATVC	05-06	631-203	631-7145
V-Star Silverado			
XVS650K/KC-V/V C V-Star Custom	98-06	631-203	631-7145
FZ700T/TC	1987	631-001	631-7401
FZX700S/SC/T/TC Fazer	86-87	631-001	631-7401
XJ700N/NC/S/SC Maxim	85-86	631-201	631-7144
XJ700XN/XNC/XS/XSC Maxim X	85-86	631-201	631-7144
XV700L/LC/N/NC Virago	84-85	631-203	631-7145
XV700CS/CSC/CT/CTC Virago	86-87	631-203	631-7145
XV700SS/SSC Virago	1986	631-203	631-7145
FZ750N/S/SC	85-86	631-001	631-7401
FZ750U/UC	1988	631-001	631-7401
FZR750RT/RU	87-88	631-001	631-7401
XJ750J/K Maxim	82-83	631-201	631-7144
XJ750MK Midnight Maxim	1983	631-201	631-7144
XJ750RH/RJ/RK Seca	81-83	631-201	631-7144
XS750D/2D/E/F	77-79	631-202	631-7146
XS750SE/SF Special	78-79	631-202	631-7146
XV750H/J/K Virago	81-83	631-203	631-7145
XXV750MK Midnight Virago	81-83	631-203	631-7145
XV750U/UC-K/KC Virago	88-98	631-203	631-7145
XV750H1/HC1/J1/JC1 Virago	96-97	631-203	631-7145
YZF750RF/RFC	1994	631-009	631-7303
YZF750RH/RHC~RK/RKC	96-98	631-009	631-7303
TDM850D/DC/E/EC	92-93	631-203	631-7145
XS850G/H	80-81	631-202	631-7146
XS850LG/LH Midnight Special	80-81	631-202	631-7146
XS850SG/SH Special	80-81	631-202	631-7146
XJ900RK Seca	1983	631-201	631-7144
XV920J/K Virago	82-83	631-203	631-7145
XV920MK Midnight Virago	1983	631-203	631-7145
XV920RH/RJ	81-82	631-203	631-7145
FZR1000T/TC/U/UC/W/WC/A/AC	87-90	631-001	631-7401
FZR1000B/BC-G/GC	91-95	631-009	631-7303
FZS1000N/NC-S/SC FZ1	01-04	631-009	631-7303
FZS1000SPR/SPRC FZ1	2003	631-009	631-7303
GTS1000AE/AEC/AF/AFC	93-94	631-009	631-7303
XV1000L/LC/N/NC Virago	84-85	631-203	631-7145
YZF1000RJ/RJC	1997	631-009	631-7303
YZF1000RK/RKC	1998	631-009	631-7303
YZF-R1L/LC-V/VZ (R1)	99-06	631-009	631-7303
YZF-R1SPV/SPVC (R1)	2006	631-009	631-7303
50th Anniversary			
FJ1100L/LC/N/NC	84-85	631-001	631-7401
XJ1100J Maxim	1982	631-202	631-7146
XS1100E/F/G/H	78-81	631-202	631-7146
XS1100LG/LH Midnight Special	80-81	631-202	631-7146
XS1100SF/SG/SH Special	79-81	631-202	631-7146
XV1100S/SC-L/LC Virago	86-99	631-203	631-7145
XV1100SH/SHC/SJ/SJC Virago	96-97	631-203	631-7145
XV1100SK/SKC Virago	1998	631-203	631-7145
XVS1100AM/AMC-AR/ARC	00-03	631-203	631-7145
V-Star 1100 Classic			
XVS1100ATR/ATRC	2003	631-203	631-7145
V-Star 1100 Silverado			

## Yamaha Street

Model	Year	Sudco Order No.	K&N Order No.
XVS1100AW V-Star 1100 Classic	2003	631-203	631-7145
XVS1100L/LC-V/V C V-Star 1100 Custom	99-06	631-203	631-7145
FJ1200S/SC/T/TC	86-87	631-001	631-7401
FJ1200W/WC/A/AC/B/BC/D/DC	89-92	631-001	631-7401
FJ1200AD/ADC/AE/AEC (ABS)	92-93	631-001	631-7401
VMX12N/NC/S/SC V-Max	85-86	631-202	631-7146
VMX12U/UC-G/GC V-Max	88-95	631-202	631-7146
VMX12H/HC-V/V C V-Max	96-06	631-009	631-7303
XVZ12TK/L/KC2 Venture	83-84	631-202	631-7146
XVZ12DL/DKC2/DN Venture Royale	84-85	631-202	631-7146
XVZ12TDK Venture Royale	1983	631-202	631-7146
FJR1300R/RC/S/SC/T/TC	03-05	-----	631-7148
FJR1300AS/ASC/AT/ATC (ABS)	04-05	-----	631-7148
XVZ13T/TC/U/UC Venture	87-88	631-202	631-7146
XVZ13DS/DSC-DE/DEC Royale	86-93	631-202	631-7146
XVZ13AH/AHC-AM/AMC Royal Star	96-00	631-009	631-7303
XVZ13AN/ANC Royal Star Boulevard	2001	631-009	631-7303
XVZ13ATH/ATHC-ATM/ATMC Royal Star Tour Classic	96-00	631-009	631-7303
XVZ13LTJ/LTJC-LTM/LTMC Royal Star Tour Deluxe	97-00	631-009	631-7303
XVZ1300AH/AHC-AN/ANC Royal Star	96-01	631-009	631-7303
XVZ1300AT Royal Star Tour Classic	96-00	631-009	631-7303
XVZ1300LTJ Royal Star Tour Deluxe	97-01	631-009	631-7303
XVZ1300TF Royal Star Venture MM	2000	631-009	631-7303
XVZ1300TF Royal Star Venture	99-04	631-009	631-7303
XVZ1300TFS Royal Star Midnight	02-04	631-009	631-7303
XV1600AL Road Star	99-03	631-009	631-7303
XV1600ALE Road Star Limited Ed.	2003	631-009	631-7303
XV1600AS Road Star MM Limited	00-03	631-009	631-7303
XV1600AT Road Star Silverado	99-03	631-009	631-7303
XV1600ATLER/ATLERC Road Star Silverado Limited Edition	2003	631-009	631-7303
XV1700AS/ASC/AT/ATC Road Star	04-05	631-009	631-7303
XV1700AV/AVC Road Star	2006	631-009	631-7303
XV1700AT Road Star Silverado	04-06	631-009	631-7303
XV1700AM Road Star Midnight	04-06	631-009	631-7303
XV1700ATM Road Star Midnight Silverado	04-06	631-009	631-7303
XV1700PC Road Star Warrior	02-06	631-009	631-7303
XV1700PCRC Road Star Warrior	2003	631-009	631-7303
XV1700PCRCB Road Star Warrior	2003	631-009	631-7303

## Yamaha ATV

YFM200N Moto-4	1985	631-204	631-7143
YFM200DXS/DXT/DXU/DXW Moto-4	86-89	631-204	631-7143
YTM200K/L/N Tri-Moto	83-84	631-204	631-7143
YTM200EK/EL	83-84	631-204	631-7143
YTM200ERN Tri-Moto	1985	631-204	631-7143
YFM225S/T/U Moto-4	86-88	631-204	631-7143
YTM225DXK/DXL/DXN Tri-Moto	83-85	631-204	631-7143
YTM225DRN/DRS Tri-Moto	85-86	631-204	631-7143
YFB250D/E/F/G/H Timberwolf	92-96	631-204	631-7143
YFB250FWF-FWM/FWMC Timberwolf	94-00	631-204	631-7143
YFB250UH/UJ/UK Timberwolf	96-98	631-204	631-7143
YFM250W/A/B Moto 4	89-91	631-204	631-7143
YFM250M/MC Bear Tracker 2WD	2000	631-204	631-7143
YFM250BT/BV Bruin 250	05-06	631-204	631-7143
YFM250XL/XLC/XM/XMC Bear Tracker	99-00	631-204	631-7143
YFM250XN/XP/XR/XS Bear Tracker	01-04	631-204	631-7143
YFM250XHN/XHP Beartracker	01-02	631-204	631-7143
YFM350AS Bruin 350 Auto 2WD	2004	631-009	631-7303
YFM350BAT/BAV Bruin 2WD	05-06	631-009	631-7303
YFM350ERT/ERU/ERW/ERA Moto-4	87-90	631-205	631-7142



**Yamaha ATV**

Model	Year	Sudco Order No.	K&N Order No.
YFM350ERD/ERE/ERF/ERG Moto-4	92-95	631-205	631-7142
YFM350FAS Bruin 350 Auto 4x4	2004	631-009	631-7303
YFM350FAHS Bruin 350 Auto 4x4	2004	631-009	631-7303
Hardwood Camo			
YFM350FAS/FAT Bruin 350 Auto 4WD	04-05	631-009	631-7303
YFM350FAV-B Bruin 4WD	2006	631-009	631-7303
YFM350FAV Bruin 4WD	2006	631-009	631-7303
YFM350FAHS/T/VBruin 4WD Hunter	04-06	631-009	631-7303
YFM350FHL/FHLC Big Bear 4WD	1999	631-205	631-7142
YFM350FWT-FWJ Big Bear 4WD	87-97	631-205	631-7142
YFM350FWBJ/FWBK/FWBKC Big Bear	97-98	631-205	631-7142
YFM350FWBL/FWBLC Big Bear	1999	631-205	631-7142
YFM350FXG-FXK Wolverine	95-98	631-205	631-7142
YFM350FXL/FXLC/FXM/FXMC	99-00	631-205	631-7142
YFM350FXN/FXNC/FXP Wolverine	01-02	631-205	631-7142
YFM350FXR/FXS/FXT Wolverine	03-05	631-205	631-7142
YFM350RSET/RSEV Raptor 350 SE	05-06	631-205	631-7142
YFM350RT/RV Raptor	05-06	631-205	631-7142
YFM350S Raptor	2004	631-205	631-7142
YFM350UH/UJ/UK/UL/ULC Big Bear	96-99	631-205	631-7142
YFM350XT-XS/XSC Warrior	87-04	631-205	631-7142
YFP350U Terrapro	1988	631-204	631-7143
YFU1W/YFU1TW Pro Hauler	1989	631-205	631-7142
YFM400P Big Bear 400 2WD	2002	631-205	631-7142
YFM400S Big Bear 400 2WD	2004	631-205	631-7142
YFM400AM/AMC/AN Kodiak 2WD	00-01	631-009	631-7303
Automatic			
YFM400AR Kodiak 4WD	2003	631-009	631-7303
YFM400FM/FMC Big Bear 4WD	2000	631-205	631-7142
YFM400FPBig Bear 4WD	2002	631-205	631-7142
Real Tree X-Tra			
YFM400FAM/FAMC/FAN Kodiak	00-01	631-009	631-7303
4WD Auto			
YFM400FAP/FAR/FARB Kodiak 4WD	02-03	631-009	631-7303
4WD Auto			
YFM400FAHM/FAHMC Kodiak 4WD	2000	631-009	631-7303
YFM400FAHN/FAHNC Kodiak 4WD	2001	631-009	631-7303
YFM400FHM Big Bear Buckmaster	2000	631-205	631-7142
YFM400FHP Big Bear 400 4WD	2002	631-205	631-7142
YFM400FHAP Kodiak 4x4 Hunter	2002	631-205	631-7142
YFM400FWE/F/G/H/J/K Kodiak	93-98	631-205	631-7142
YFM400FWR Big Bear	2003	631-205	631-7142
YFM400FWAHM/FWAHMC Kodiak	2000	631-009	631-7303
4WD Realtree			
YFM400FWM/FWNMC Big Bear 4WD	2000	631-205	631-7142
YFM400FWNN Big Bear 4WD	2001	631-205	631-7142
YFM400FWNHM/FWNHMC/FWNHN	00-01	631-205	631-7142
Big Bear Buckmaster 4WD			
YFM400HIP 2WD Real Tree X-tra	2002	631-205	631-7142
YFM400NM/NMC/NN Big Bear 2WD	00-01	631-205	631-7142
YFM400NR Big Bear 2WD	2003	631-205	631-7142
YFM400NHN Big Bear 2WD	2001	631-205	631-7142
YFM400FS/FT/FV Big Bear 400 4x4	04-06	631-205	631-7142
YFM400AS Kodiak 400 2WD	2004	631-009	631-7303
YFM400FAS/FAT/FAV Kodiak 4x4	04-06	631-009	631-7303
YFM400FAHS/FAHT/FAHV Kodiak 400	04-06	631-009	631-7303
4x4 Hardwoods			
YFM450FAR/FARB Kodiak 4WD Auto	2003	631-009	631-7303
YFM450FAS/FAT Kodiak 450 Auto 4x4	04-05	631-009	631-7303
YFM450FAV Kodiak 450 Auto 4x4	2006	631-009	631-7303
YFM450FAHS/FAHT/FAHV Kodiak 450	04-06	631-009	631-7303
Auto 4x4 Hardwoods			
YFM450FXV Wolverine 450 4x4 Sport	2005	631-009	631-7303
YFZ450LES Limited Edition	2004	————	631-7141
YFZ450SET Special Edition	2005	————	631-7141
YFZ450S/T/V	04-06	————	631-7141
YFM600FWAK/FWAL/FWALC Grizzly	98-99	631-203	631-7145
YFM600FWAM/FWAMC Grizzly	2000	631-203	631-7145

**Yamaha ATV**

Model	Year	Sudco Order No.	K&N Order No.
YFM660FWAN Grizzly	2001	631-203	631-7145
YFM600FWAHN Hunter Edition	2001	631-203	631-7145
YFM600HM/HMC Grizzly Hunting	2000	631-203	631-7145
YFM660FP Grizzly 660	2002	631-009	631-7303
YFM660FPS Grizzly 660	2002	631-009	631-7303
Metallic Silver			
YFM660FR/FS Grizzly 660	03-04	631-009	631-7303
YFM660FAHT Grizzly 660 Hunter	2005	631-009	631-7303
YFM660FHR/FHS Grizzly 660	03-04	631-009	631-7303
4X4 Wetlands Hunter Edition			
YFM660FHSWL Grizzly 660 Auto 4x4	03-04	631-009	631-7303
Wetland			
YFM660FLES Grizzly 660	2004	631-009	631-7303
Auto 4x4 Limited Edition			
YFM660RR/RS/RT Raptor 660	03-05	————	631-7147
YFM660RLER/RLES Raptor	03-04	————	631-7147
Limited Edition Black			
YFM660RSET Raptor 660 SE	2005	————	631-7147
YFM660FAT/FAV Grizzly 660	05-06	631-009	631-7303
YFM660FAHT/FAHV Grizzly 660 Hunter	05-06	631-009	631-7303
YFM660FAHWT Grizzly 660	2005	631-009	631-7303
Hunter Wetland			
YFM660FASET/FASEV Grizzly 660	05-06	631-009	631-7303
Special Edition			
YFM660FASEV Grizzly 660	2006	631-009	631-7303
Ducks Unlimited Edition			
YFM700RV Raptor 700	2006	631-203	631-7145
YFM700RSPV Raptor 700	2006	631-203	631-7145
50th Anniversary			

**Yamaha Dual Sport/ Offroad**

XT125J/K/KC Dual Sport	82-83	631-204	631-7143
BW200N/S	85-86	631-204	631-7143
BW200ES/ET/EU	86-88	631-204	631-7143
TW200T/TC-V/V/C Trailway	87-06	631-204	631-7143
XT200J/K/KC Dual Sport	82-83	631-204	631-7143
TT225S/T	86-87	631-204	631-7143
TT-R225L/LC/M/MC/N/NC	99-01	631-204	631-7143
TT-R225P/PC/R/RC/S/SC	02-04	631-204	631-7143
XT225D/DC-V/V/C Serrow	92-03	631-204	631-7143
TT-R230T/TC/V/V/C	05-06	631-204	631-7143
TT250G/H/J	80-82	631-203	631-7145
TTR250L/LC-V/V/C	99-06	631-205	631-7142
WR250FN/FP	01-02	631-205	631-7142
WR250FR/FS/FT/FV	03-06	————	631-7141
XT250G/H/J/K/KC Dual Sport	80-83	631-203	631-7145
XT250L/LC Dual Sport	1984	631-204	631-7143
YZ250FN/FP Offroad	01-02	631-205	631-7142
YZ250FR/FS/FT/FV	03-06	————	631-7141
BW350T/U	87-88	631-203	631-7145
TT350S/T Offroad	86-87	631-204	631-7143
XT350N/NC-M/MC Dual Sport	85-00	631-204	631-7143
WR400FK/FL/FM Offroad	98-00	631-205	631-7142
YZ400FK/FL Offroad	98-99	631-205	631-7142
WR426FN/FP Offroad	01-02	631-205	631-7142
YZ426FM/FN/FP Offroad	00-02	631-205	631-7142
WR450FR/FS/FT/FV	03-06	————	631-7141
YZ450FR/FS/FT/FV	03-06	————	631-7141
TT500C/D/E/F/G/H Offroad	76-81	631-203	631-7145
XT500C/D/E/F/G/H Dual Sport	76-81	631-203	631-7145
XT550J/K Dual Sport	82-83	631-203	631-7145
TT600K/L/N/S Offroad	83-86	631-203	631-7145
XT600L/LC-EG/EGC Dual Sport	84-95	631-203	631-7145



# PC Racing Oil Filters



## FLO® Stainless Steel Reusable "Spin On" Oil Filters

This should be the last oil filter you will ever buy! Made from laser cut, medical grade, 304 stainless steel micronic filter cloth. This filter provides 200% more filter area in many cases. Our stainless filter catches items down to 35 microns, which is about 3 times better than most good paper or brass filters. Unlike glued paper filters, the FLO Oil Filter pleat seam is welded and able to withstand up to 600 degrees.

- Cleanable and Reusable
- Superior Filtration – 35 microns!
- Proven Aerospace, NASCAR
- Indy and Formula 1 Technology
- High Flow Rate
- Easy Filter Element Inspection
- Unaffected by Water
- Heat or Pressure
- Environmentally Friendly
- Pays for itself

### Arctic Cat

Application	Year		Order No.
371	1998	PCS2	945-141
375	2002	PCS2	945-141
400	98-07	PCS2	945-141
454	96-98	PCS2	945-141
493	1998	PCS2	945-141
500	99-09	PCS2	945-141
650 Twin	04-06	PCS1	945-140
650 H1	06-08	PCS2	945-141
Prowler 650	06-09	PCS2	945-141
700	06-09	PCS2	945-141
Prowler 700	08-09	PCS2	945-141

### Honda

CB400F CB-1	88-90	PCS1	945-140
CB600F (599)	04-06	PCS1	945-140
CBR600	87-07	PCS1	945-140
VT600 Shadow	88-07	PCS1	945-140
CBR600RR	03-08	PCS1	945-140
NT650	88-91	PCS1	945-140
XL600V Transalp	89-90	PCS1	945-140
CB700 Nighthawk	91-03	PCS1	945-140
VF750C Magna	82-83	PCS1	945-140
VF750C Magna	1988	PCS1	945-140
VF750C Magna	94-03	PCS1	945-140
VFR750F	1986	PCS1	945-140
VFR750F	90-97	PCS1	945-140
VT750 Shadow	97-08	PCS1	945-140
PC800 Pacific Coast	88-90	PCS1	945-140
PC800 Pacific Coast	94-98	PCS1	945-140
VFR800F	98-07	PCS1	945-140
CB900F (919)	02-07	PCS1	945-140
CBR900RR	93-99	PCS1	945-140
CBR929RR	00-01	PCS1	945-140
CBR954	02-03	PCS1	945-140
CB1000 Custom	94-95	PCS1	945-140
CBR1000F	87-96	PCS1	945-140
CBR1000RR	04-08	PCS1	945-140
RVT1000R (RC51)	01-06	PCS1	945-140
VF1000 Interceptor	84-86	PCS1	945-140
CBR1100XX	97-03	PCS1	945-140

### Honda

Application	Year	Flo No.	Order No.
ST1100	91-92	PCS1	945-140
VF1100 Magna	83-86	PCS1	945-140
VT1100 Shadow	89-07	PCS1	945-140
VTR1000F Super Hawk	96-06	PCS1	945-140
ST1300	03-08	PCS1	945-140
VTX1300	03-08	PCS1	945-140
GL1500 (G.W. Aspen, Inters.)	88-00	PCS1	945-140
GL1500 Valkyrie	97-03	PCS1	945-140
GL1800 Goldwing	01-08	PCS1	945-140
NRX1800 Rune	04-05	PCS1	945-140
VTX1800	02-08	PCS1	945-140

### Kawasaki

KVF300 Prairie	99-02	PCS1	945-140
KVF360 Prairie	03-09	PCS1	945-140
KLF400 Bayou	97-01	PCS1	945-140
KVF400 Prairie	97-02	PCS1	945-140
EX500 Ninja	97-08	PCS1	945-140
EX600 Ninja R	06-08	PCS1	945-140
Mule 600 2x4	05-09	PCS1	945-140
ZX6	90-02	PCS1	945-140
ZX6R	95-08	PCS1	945-140
ZX6RR	03-08	PCS1	945-140
ZZR600	03-08	PCS1	945-140
Mule 610 4x4	05-09	PCS1	945-140
KVF650 Brute Force	05-09	PCS1	945-140
KVF650 Prairie	02-03	PCS1	945-140
W650 Retro	00-02	PCS1	945-140
KFX700	04-09	PCS1	945-140
KVF700 Prairie	04-06	PCS1	945-140
ZX7	89-99	PCS1	945-140
ZX7R	91-03	PCS1	945-140
ZX7RR	1996	PCS1	945-140
KVF750 Brute Force	05-09	PCS1	945-140
Teryx 750	08-09	PCS1	945-140
VN750 Vulcan	94-06	PCS1	945-140
Z750S	05-08	PCS1	945-140
ZX750 Ninja, 750L	91-02	PCS1	945-140
VN800 Vulcan	95-06	PCS1	945-140
VN900 Vulcan	06-08	PCS1	945-140
ZX9R Ninja	94-03	PCS1	945-140
Mule 1000	93-02	PCS1	945-140
ZX10R	04-07	PCS1	945-140
Z1000	03-08	PCS1	945-140
ZX12R	00-05	PCS1	945-140
ZX14R	06-08	PCS1	945-140
VN1500 Vulcan	87-08	PCS1	945-140
VN1600 Vulcan	03-08	PCS1	945-140
VN2000 Vulcan	04-08	PCS1	945-140
Mule 2010, 2020, 2030	93-02	PCS1	945-140
Mule 3000 3x4	01-08	PCS1	945-140
Mule 3010 4x4	01-08	PCS1	945-140
Mule 3010 Diesel 4x4	01-08	PCS1	945-140
Mule 4000, 4010	2009	PCS1	945-140

### KTM

Duke/Adventure/SMC - LC4			
Spin on filter on front frame	99-08	PCS1	945-140

## Polaris

Application	Year	Flo No.	Order No.
450 Super Utility	2000	PCS1	945-140
425 Ranger 4x2	01-04	PCS1	945-140
500 ATP	04-05	PCS1	945-140
500L Big Boss	98-00	PCS1	945-140
500 Magnum/RMK	99-02	PCS1	945-140
500 Ranger 4x2	07-08	PCS1	945-140
500 Ranger 4x4	01-08	PCS1	945-140
500 Ranger 6x6	99-05	PCS1	945-140
500 Scrambler	98-08	PCS1	945-140
500 Sportsman	96-08	PCS1	945-140
500 Sportsman 6x6	00-08	PCS1	945-140
500 X-Plorer	1997	PCS1	945-140
600 Twin	03-05	PCS1	945-140
MV7 700		PCS1	945-140
700 Ranger XP 4x4	06-08	PCS1	945-140
700 Ranger 6x6	06-08	PCS1	945-140
700 Sportsman	02-08	PCS1	945-140
800 Sportsman	02-08	PCS1	945-140
800 Ranger RZR	2008	PCS1	945-140

## Suzuki

Boulevard S40	05-08	PCS2	945-141
Boulevard C50	05-08	PCS2	945-141
Boulevard C90	05-08	PCS2	945-141
Boulevard M50	05-08	PCS2	945-141
Boulevard S83	05-08	PCS2	945-141
M95	2005	PCS2	945-141
M109 R&T	06-08	PCS2	945-141
LTA400 Eiger	02-07	PCS2	945-141
LTA400 King Quad	08-09	PCS2	945-141
LTA450 King Quad	07-09	PCS2	945-141
LTA500F Quadmaster	00-01	PCS2	945-141
LTA500F Vision	02-07	PCS2	945-141
LT-F500F Quadrunner	98-02	PCS2	945-141
GSF600S Bandit	96-03	PCS2	945-141
GSX600F Katana	88-06	PCS2	945-141
GSXR600	92-93	PCS2	945-141
GSXR600	97-08	PCS2	945-141
RF600R	94-96	PCS2	945-141
620 QUV	05-06	PCS1	945-140
DL650 V-Strom	04-08	PCS2	945-141
GSF650 Bandit	05-08	PCS2	945-141
SV650	99-08	PCS2	945-141
SV650S	99-08	PCS2	945-141
LTA700X King Quad	98-07	PCS2	945-141
LTZ700F Twin Peaks	98-05	PCS1	945-140
VS700 Intruder	1987	PCS2	945-141
LTA750 King Quad	08-09	PCS2	945-141
GSX750F Katana	89-06	PCS2	945-141
GSXR750	86-08	PCS2	945-141
VS750 Intruder	88-91	PCS2	945-141
VL800 Volusia	01-04	PCS2	945-141
VS800 Intruder	92-04	PCS2	945-141
VX800	90-93	PCS2	945-141
VZ800 Marauder	97-02	PCS2	945-141
RF900R	94-97	PCS2	945-141
DL1000 V-Strom	02-08	PCS2	945-141
GSXR1000	01-08	PCS2	945-141
TL1000S	97-01	PCS2	945-141
GSX1100F Katana	88-93	PCS2	945-141
SV1000	04-08	PCS2	945-141
SV1000S	04-08	PCS2	945-141
GSXR1100	86-98	PCS2	945-141
GSF1200 Bandit	97-05	PCS2	945-141
GSF1250 Bandit	07-08	PCS2	945-141
GSXR1300 Hayabusa	99-08	PCS2	945-141
GV1400 Cavalcade	87-88	PCS2	945-141
VS1400 Intruder	87-04	PCS2	945-141
VL1500 Intruder LC	98-04	PCS2	945-141
VZ1600 Marauder	2004	PCS1	945-140

## Triumph

Speed 4 599	02-06	PCS1	945-140
Daytona 600	2004	PCS1	945-140
TT600	00-03	PCS1	945-140
Daytona 650	2004	PCS1	945-140

## Triumph

Application	Year	Flo No.	Order No.
Daytona 675	06-08	PCS1	945-140
America 790	03-06	PCS1	945-140
Bonnieville 790	01-06	PCS1	945-140
Speedmaster 790	03-06	PCS1	945-140
America 865	07-08	PCS1	945-140
Bonnieville 865	05-08	PCS1	945-140
Speedmaster 865	07-08	PCS1	945-140
Scrambler	06-08	PCS1	945-140
Speed Triple 885	97-98	PCS1	945-140
Tiger 885	2000	PCS1	945-140
Thruxton 900	04-08	PCS1	945-140
Daytona 955	97-06	PCS1	945-140
Speed Triple 955	99-06	PCS1	945-140
Sprint RS 955	00-03	PCS1	945-140
Sprint ST 955	99-06	PCS1	945-140
Tiger 955	01-06	PCS1	945-140
Speed Triple 1050	07-08	PCS1	945-140
Sprint ST 1050	07-08	PCS1	945-140
Tiger 1050	07-08	PCS1	945-140
Rocket III	04-09	PCS1	945-140

## Victory

Cruiser	99-05	PCS1	945-140
Hammer	05-08	PCS1	945-140
Kingpin	04-08	PCS1	945-140
Touring Cruiser	02-07	PCS1	945-140
Vegas	03-08	PCS1	945-140

## Yamaha

YFM350 Bruin/ Grizzly	04-09	PCS1	945-140
YFM400 Kodiak/ Grizzly	00-07	PCS1	945-140
YXR450 Rhino (Side x Side)	06-09	PCS1	945-140
YFM450 Kodiak/ Grizzly	02-07	PCS1	945-140
YFM450 Wolverine	06-08	PCS1	945-140
FZ6	05-08	PCS1	945-140
FZR600	91-01	PCS1	945-140
XJ600 Seca II	92-98	PCS1	945-140
YZF600R	95-07	PCS1	945-140
YZF-R6	99-09	PCS1	945-140
YXR660 Rhino (Side x Side)	04-07	PCS1	945-140
YFM660 Grizzly	02-07	PCS1	945-140
YFM660 Raptor	01-05	PCS1	945-140
YXR700 Rhino	08-09	PCS1	945-140
YFM700 Grizzly	07-09	PCS1	945-140
YZF750	94-97	PCS1	945-140
FZ1	01-08	PCS1	945-140
FZR1000	91-95	PCS1	945-140
GTS1000	93-94	PCS1	945-140
YZF1000	97-98	PCS1	945-140
YZF R1	98-08	PCS1	945-140
VMX12 V-Max	96-08	PCS1	945-140
FJR1300	03-08	PCS1	945-140
XVZ13 Venture / Royal Star	96-07	PCS1	945-140
XV1600 Road Star	99-03	PCS1	945-140
XV1700 Road Star	04-07	PCS1	945-140
XV1900 Roadliner	06-07	PCS1	945-140
XV1900 Stratoliner	06-07	PCS1	945-140



# PC Racing Oil Filters



## FLO® Stainless Steel 'Drop In' Oil Filters

This should be the last oil filter you will ever buy! Made from laser cut, medical grade, 304 stainless steel micronic filter cloth, this filter provides 200% more filter area in many cases. Our stainless filter catches items down to 35 microns, which is about 3 times better than most good paper or brass filters. Unlike glued paper filters, the FLO Oil Filter pleat seam is welded and able to withstand up to 600 degrees.

### Honda

Application	Year	Flo No.	Order No.
CRF150 R	07-11	PC116	<b>945-151</b>
CRF250 R/X	04-11	PC116	<b>945-151</b>
CRF450 R/X	02-11	PC116	<b>945-151</b>
TRX250/300/350/400/450 Foreman	85-11	PC112	<b>945-150</b>
TRX450 R	04-11	PC116	<b>945-151</b>
TRX700XX	08-11	PC112	<b>945-150</b>
XR250/350/400/500/600/650	84-11	PC112	<b>945-150</b>

### Husaberg

4-Stroke Models (Front)*	all	PC155	<b>945-154</b>
4-Stroke Models (Rear)**	all	PC157	<b>945-155</b>

Note: \*Tall Filter, \*\* Short Filter

### Kawasaki

KLX110	02-11	PC112	<b>945-150</b>
KLX140	08-11	PC112	<b>945-150</b>
KLX250/300	94-11	PC112	<b>945-150</b>
KXF250	04-11	PC207	<b>945-157</b>
KFX400 (ATV)	05-11	PC139	<b>945-152</b>
KLX400	03-04	PC139	<b>945-152</b>
KFX450 (ATV)	08-11	PC112	<b>945-150</b>
KLX450	08-11	PC112	<b>945-150</b>
KX450F	06-11	PC112	<b>945-150</b>

### KTM

250/400/450/520/525 EXC-F (Front)*	00-07	PC155	<b>945-154</b>
250/400/450/520/525 EXC-F (Rear)**	00-07	PC157	<b>945-155</b>
250 EXC-F (single filter engine)	2009	PC155	<b>945-154</b>
250 SX-F (single filter engine)	05-10	PC155	<b>945-154</b>
250 XC-F (single filter engine)	2009	PC155	<b>945-154</b>
250/400/450/525 XC-F (Front)*	00-07	PC155	<b>945-154</b>
250/400/450/525 XC-F (Rear)**	00-07	PC157	<b>945-155</b>
250/400/450/520/525 SX-F (Front)*	00-05	PC155	<b>945-154</b>
250/400/450/520/525 SX-F (Rear)**	00-05	PC157	<b>945-155</b>
450/525 SX-F (Front)*	2006	PC155	<b>945-154</b>
450/525 SX-F (Rear)**	2006	PC157	<b>945-155</b>
450 SX	07-09	PC167	<b>945-156</b>
450/525 XC (ATV) (Front)*	08-09	PC155	<b>945-154</b>
450/525 XC (ATV) (Rear)**	08-09	PC157	<b>945-155</b>
450 XC/XCR/EXC/SMR	08-09	PC167	<b>945-156</b>
505 SX/XC	08-09	PC167	<b>945-156</b>
530 EXC/XCR	08-09	PC167	<b>945-156</b>
540/620/625/640/LC4	92-07	PC155	<b>945-154</b>

Note: \*Tall Filter, \*\* Short Filter

## Polaris

Application	Year	Flo No.	Order No.
500 Predator	03-09	PC112	<b>945-150</b>
450/525 Outlaw (Front)*	08-10	PC155	<b>945-154</b>
450/525 Outlaw (Rear)**	08-09	PC157	<b>945-155</b>

Note: \*Tall Filter, \*\* Short Filter

## Suzuki

RM-Z 250	04-11	PC207	<b>945-157</b>
DR-Z 400	00-11	PC139	<b>945-152</b>
LT-Z 400 QuadSport	03-11	PC139	<b>945-152</b>
LT-R 450 Quadracer	06-11	PC139	<b>945-152</b>
RM-Z 450	05-11	PC207	<b>945-157</b>

## Yamaha

YFM250 Raptor 250	08-11	PC141	<b>945-153</b>
TTR250	99-11	PC141	<b>945-153</b>
XV250 V-Star	08-11	PC145	<b>945-158</b>
XV250 Virago	04-07	PC145	<b>945-158</b>
YZ/WR250/400/426/450F	98-11	PC141	<b>945-153</b>
YMF350	86-11	PC141	<b>945-153</b>
YFB450 Kodiak	02-09	PC141	<b>945-153</b>
YFM400 (all)	93-11	PC141	<b>945-153</b>
YFZ450	04-11	PC141	<b>945-153</b>
YFZ450X	10-11	PC141	<b>945-153</b>
650 Drag Star	98-11	PC145	<b>945-158</b>
650 V-Star	98-11	PC145	<b>945-158</b>
Raptor 700	06-11	PC145	<b>945-158</b>
1100 V-Star	99-09	PC145	<b>945-158</b>
1100 Drag Star	02-09	PC145	<b>945-158</b>



## Super Clean Cleaner

Clean the stainless steel filter element, spring and house with **Super Clean**. Lightly blow air through the filter from the inside out to remove any remaining particles or **Super Clean**.

Order No. **800-600**



## Red Line High Performance Motorcycle Oils

Description	Order No.
10W30	<b>900-880</b>
10W40	<b>900-881</b>
20W50	<b>900-883</b>
20W60HD	<b>900-805</b>

# Clutch Plates, Clutch Springs, & Clutch Cover Gasket

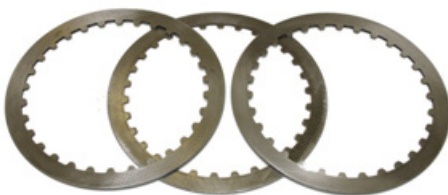

## Sudco Clutch Plates & Clutch Springs

SUDCO friction plates, steel drive plates and stiffer clutch spring sets are sourced from the OEM mfgs. in Japan. Highest quality clutch components available. Clutch plates and clutch cover gaskets are sold each. Clutch springs sold in sets. Order per quantity needed.

### Honda Street

Model	Year	Friction Plate each	Drive(Metal) Plate each	Spring Set	Gasket each
MB5-50	1982	12-1019 (3)	12-1005 (2)	614-131 (4)	_____
NSF50	1990	12-1019 (3)	13-1005 (2)	614-131 (4)	_____
NSR50	2004	12-1019 (4)	13-1005 (3)	614-131 (4)	_____
C70 Passport	80-83	12-1011 (2)	13-1001 (1)	614-115 (4)	_____
		12-1077 (1)	13-1020 (1)	_____	_____
CL70K0/K1-K3 Scrambler	69-73	12-1012 (2)	_____ (2)	614-115 (4)	_____
CT70 Trail 70	76-82	12-1011 (2)	13-1001 (1)	614-115 (4)	_____
		12-1077 (1)	13-1020 (1)	_____	_____
XL75	77-79	12-1019 (5)	13-1005 (4)	614-138 (4)	643-1026
XL80S	80-85	12-1019 (3)	13-1005 (2)	614-129 (4)	643-1026
ST90/K1/K2 Trail Sport 90	73-75	12-1017 (3)	_____ (4)	_____ (4)	_____
CB100K0/K1/K2 Super Sport	70-72	12-1019 (5)	13-1005 (4)	614-101 (4)	_____
CL100K0/K1/K2 Scrambler	70-72	12-1019 (5)	13-1005 (4)	614-101 (4)	_____
CL100S/S2/S3 Scrambler	71-73	12-1019 (5)	13-1005 (4)	614-101 (4)	_____
SL100K0-K3 Motosport	70-73	12-1019 (5)	13-1005 (4)	614-101 (4)	_____
XL100K0/K1	74-75	12-1019 (5)	13-1005 (4)	614-101 (4)	_____
XL100	76-78	12-1019 (5)	13-1005 (4)	614-101 (4)	_____
XL100S	79-80	12-1019 (4)	13-1005 (3)	614-138 (4)	643-1026
XL100S	81-85	12-1019 (4)	13-1005 (3)	614-129 (4)	643-1026
CT110 Trail 110	80-84	12-1017 (3)	_____	614-132 (4)	643-1023
CT110 Trail 110	1986	12-1017 (3)	_____	614-132 (4)	643-1023
CB125S/S1/S2	73-75	12-1019 (5)	13-1005 (4)	614-101 (4)	_____
CB125S	1976	12-1019 (5)	13-1005 (4)	614-101 (4)	_____
CB125S	78-80	12-1019 (5)	13-1005 (4)	614-101 (4)	_____
CB125S	81-82	12-1019 (5)	13-1005 (4)	614-101 (4)	643-1016
CB125S	84-85	12-1019 (5)	13-1005 (4)	614-101 (4)	_____
CB125TT	1990	12-1019 (4)	13-1005 (4)	614-134 (4)	_____
		12-1068 (1)	_____	_____	_____
CL125S/S1 Scrambler 125	73-74	12-1019 (5)	13-1005 (4)	_____ (4)	_____
CT125 Trail 125	1977	12-1019 (5)	13-1005 (4)	614-101 (4)	_____
NX125	88-90	12-1019 (4)	13-1005 (4)	614-109 (4)	_____
		12-1068 (1)	_____	_____ (4)	_____
SL125K0/K1/K2 Motosport	71-73	12-1019 (5)	13-1005 (4)	_____ (4)	_____
XL125K0/K1	74-75	12-1019 (5)	13-1005 (4)	_____ (4)	_____
XL125	76-78	12-1019 (5)	13-1005 (4)	614-101 (4)	_____
XL125S	79-82	12-1019 (5)	13-1005 (4)	614-137 (4)	643-1016
XL125S	84-85	12-1019 (5)	13-1005 (4)	614-137 (4)	643-1016
CA175 Touring 175	68-69	12-1034 (5)	13-1046 (4)	_____ (4)	_____
CB175K3-K7 Super Sport	69-73	12-1034 (5)	13-1046 (4)	_____ (4)	_____
CL175K0/K3-K7 Scrambler	68-73	12-1034 (5)	13-1046 (4)	_____ (4)	_____
CM185T Twinstar	78-79	12-1019 (5)	13-1005 (4)	_____ (4)	_____
XL185S	79-83	12-1019 (5)	13-1005 (4)	614-101 (4)	643-1016
CB200	1974	12-1034 (5)	13-1046 (4)	_____ (4)	_____
CB200T	75-76	12-1034 (5)	13-1046 (4)	_____ (4)	_____
CL200 Scrambler	1974	12-1034 (5)	13-1046 (4)	_____ (4)	_____
CM200T Twinstar	80-82	12-1019 (5)	13-1046 (4)	614-150 (4)	_____
TLR200 Reflex	86-87	12-1019 (5)	13-1005 (4)	614-154 (4)	643-1016
TR200 Fatcat	1986	12-1019 (5)	13-1006 (4)	614-148 (4)	643-1059
XL200R	83-84	12-1019 (5)	13-1005 (4)	614-105 (4)	643-1016
CB250 Nighthawk	91-06	12-1019 (6)	13-1006 (6)	614-150 (4)	_____
CM250C Custom	82-83	12-1019 (6)	13-1005 (6)	614-150 (4)	_____
CMX250C Rebel	85-87	12-1019 (6)	13-1005 (6)	614-150 (4)	_____
CMX250C Rebel	96-97	12-1019 (6)	13-1006 (6)	614-150 (4)	_____
CMX250C Rebel	99-06	12-1019 (6)	13-1006 (6)	614-150 (4)	_____
CMX250C2 Rebel	99-00	12-1019 (6)	13-1006 (6)	614-150 (4)	_____
CMX250CD Rebel 250 L	1986	12-1019 (6)	13-1005 (6)	614-150 (4)	_____
MT250/K1 Elsinore	74-75	12-1061/3 (7)	13-1018 (6)	_____	_____

### Honda Street

Model	Year	Friction Plate each	Drive(Metal) Plate each	Spring Set	Gasket each
NX250	88-90	12-1042/2 (6)	13-1011 (5)	614-152 (4)	_____
XL250/K1/K2 Motosport	72-75	12-1061/3 (7)	13-1025 (6)	614-101 (4)	_____
XL250	1976	12-1061/3 (7)	13-1029 (6)	614-101 (4)	_____
XL250S	78-80	12-1042 (4)	13-1046 (3)	614-135 (4)	643-1009
XL250S	1981	12-1042 (4)	13-1046 (4)	614-135 (4)	_____
		12-1034 (1)	_____	_____	_____
XL250R	82-83	12-1042 (4)	13-1046 (4)	614-135 (4)	_____
		12-1034 (1)	_____	_____	_____
XL250R	84-87	12-1042/2 (5)	13-1011 (5)	614-127 (4)	_____
XR250L	91-96	12-1042/2 (6)	13-1011 (5)	614-127 (4)	_____
VTR250 Interceptor	88-90	12-1019 (6)	13-1030 (6)	614-152 (4)	_____
		12-1068 (1)	_____	_____	_____
CB350F/F1 Super Sport	72-74	12-1042 (6)	13-1046 (6)	614-101 (4)	643-1014
		12-1034 (1)	13-1036 (1)	_____	_____
CB350G Super Sport	1973	12-1061/3 (8)	_____ (8)	614-102 (4)	643-1013
CB350K0-K4 Super Sport	68-73	12-1061/3 (8)	_____ (8)	614-102 (4)	643-1013
CL350K0-K5 Scrambler	68-73	12-1061/3 (8)	_____ (8)	614-102 (4)	643-1013
SL350/K1/K2 Moto Sport	70-73	12-1061/3 (8)	_____ (8)	614-102 (4)	643-1013
XL350/K1	74-75	12-1061/3 (7)	13-1025 (6)	(4)	_____
XL350	76-78	12-1061/3 (7)	13-1025 (6)	(4)	_____
XL350R	84-85	12-1042/2 (5)	13-1011 (5)	614-146 (4)	_____
		12-1034 (1)	_____	_____	_____
CB360/G	1974	12-1061/3 (8)	_____ (8)	614-102 (4)	_____
CB360T	75-76	12-1061/3 (8)	_____ (8)	614-102 (4)	_____
CJ360T	76-77	12-1061/3 (8)	_____ (8)	614-102 (4)	_____
CB400F CB1	89-90	12-1059 (5)	13-1017 (4)	614-110 (4)	_____
		12-1061/2 (1)	_____ (1)	_____	_____
CB400F Super Sport	75-77	12-1042 (6)	13-1046 (6)	614-101 (4)	643-1008
		12-1034 (1)	13-1036 (1)	_____	_____
CB400TI Hawk	78-79	12-1042 (6)	13-1047 (6)	614-110 (4)	_____
		12-1034 (1)	_____	_____	_____
CB400TII Hawk	78-79	12-1042 (6)	13-1047 (6)	614-110 (4)	_____
		12-1034 (1)	_____	_____	_____
CB400T Hawk	80-81	12-1042 (6)	13-1047 (6)	614-110 (4)	_____
		12-1034 (1)	_____	_____	_____
CM400C Custom	1981	12-1042 (6)	13-1047 (6)	614-110 (4)	_____
		12-1034 (1)	_____	_____	_____
CM400E	80-81	12-1042 (6)	13-1047 (6)	614-110 (4)	_____
		12-1034 (1)	_____	_____	_____
CM400T	79-81	12-1042(6)	13-1047(6)	614-110 (4)	_____
		12-1034 (1)	_____	_____	_____
CB450K1-K7 Super Sport	68-74	12-1061/2 (7)	13-1033 (6)	_____ (4)	_____
		_____	_____ (1)	_____	_____
CB450T Hawk	1982	12-1042 (6)	13-1047 (6)	614-110 (4)	_____
		12-1034 (1)	_____	_____	_____
CB450SC Nighthawk	82-83	12-1042 (6)	13-1047 (6)	614-107 (4)	_____
		12-1034 (1)	_____	_____	_____
CB450SC Nighthawk	85-86	12-1042 (6)	13-1047 (6)	614-107 (4)	_____
		12-1034 (1)	_____	_____	_____
CL450K1-K6 Scrambler	68-74	12-1061/2 (7)	13-1033 (6)	(4)	_____
		_____	_____ (1)	_____	_____
CM450C Custom	1982	12-1042 (6)	13-1047 (6)	614-110 (4)	_____
		12-1034 (1)	_____	_____	_____
CM450E	82-83	12-1042 (6)	13-1047 (6)	614-110 (4)	_____
		12-1034 (1)	_____	_____	_____
CMX450C Rebel	86-87	12-1042 (6)	13-1047 (6)	(4)	_____
		12-1034 (1)	_____ (1)	_____	_____



# Clutch Plates, Clutch Springs, & Clutch Cover Gasket

## Honda Street

Model	Year	Friction Plate each	Drive(Metal) Plate each	Spring Set	Gasket each
CB500T	75-76	<b>12-1061/2</b> (7)	<b>13-1033</b> (6)	_____ (4)	_____
CB500/K1/K2	71-73	<b>12-1059</b> (7)	_____ (7)	<b>614-105</b> (4)	_____
CX500	78-79	<b>12-1061/3</b> (6)	<b>13-1025</b> (5)	<b>614-109</b> (4)	_____
		<b>12-1033</b> (1)	<b>13-1039</b> (1)	_____	_____
CX500C Custom	79-82	<b>12-1061/3</b> (6)	<b>13-1025</b> (5)	<b>614-109</b> (4)	_____
		<b>12-1033</b> (1)	<b>13-1039</b> (1)	_____	_____
CX500D Deluxe	79-81	<b>12-1061/3</b> (6)	<b>13-1025</b> (5)	<b>614-109</b> (4)	_____
		<b>12-1033</b> (1)	<b>13-1039</b> (1)	_____	_____
FT500 Ascot	82-83	<b>12-1042</b> (6)	<b>13-1046</b> (7)	<b>614-124</b> (4)	<b>643-1041</b>
		<b>12-1034</b> (1)	_____	_____	_____
GB500	89-90	<b>12-1054</b> (6)	<b>13-1015</b> (6)	<b>614-125</b> (4)	_____
		<b>12-1088</b> (1)	_____	_____	_____
GL500 Silverwing	81-82	<b>12-1061/3</b> (6)	<b>13-1025</b> (5)	<b>614-109</b> (4)	_____
		<b>12-1033</b> (1)	<b>13-1039</b> (1)	_____	_____
GL500I Silverwing Interstate	81-82	<b>12-1061/3</b> (6)	<b>13-1025</b> (5)	<b>614-109</b> (4)	_____
		<b>12-1033</b> (1)	<b>13-1039</b> (1)	_____	_____
VF500C Magna	84-85	<b>12-1019</b> (8)	<b>13-1030</b> (8)	<b>614-148</b> (4)	<b>643-1049</b>
		<b>12-1068</b> (1)	_____	_____	_____
VF500F Interceptor	84-86	<b>12-1019</b> (8)	<b>13-1030</b> (8)	<b>614-148</b> (4)	<b>643-1049</b>
		<b>12-1068</b> (1)	_____	_____	_____
VT500C Shadow	83-84	<b>12-1042</b> (5)	<b>13-1047</b> (5)	<b>614-125</b> (4)	_____
		<b>12-1034</b> (1)	_____	_____	_____
VT500C Shadow	85-86	<b>12-1042</b> (5)	<b>13-1047</b> (5)	_____ (4)	_____
		<b>12-1034</b> (1)	_____	_____	_____
VT500FT Ascot	83-84	<b>12-1042</b> (5)	<b>13-1047</b> (5)	<b>614-125</b> (4)	_____
		<b>12-1034</b> (1)	_____	_____	_____
XL500R Dual Sport	1982	<b>12-1042</b> (6)	<b>13-1014</b> (6)	<b>614-107</b> (4)	_____
		<b>12-1034</b> (1)	_____	_____	_____
XL500S Dual Sport	79-81	<b>12-1042</b> (6)	<b>13-1014</b> (6)	<b>614-107</b> (4)	<b>643-1009</b>
		<b>12-1034</b> (1)	_____	_____	_____
CB550K0/K1	74-75	<b>12-1061/3</b> (7)	<b>13-1017</b> (5)	<b>614-105</b> (4)	_____
CB550/K	76-78	<b>12-1061/3</b> (6)	<b>13-1017</b> (5)	<b>614-105</b> (4)	_____
		<b>12-1070</b> (1)	_____	_____	_____
CB550F Super Sport	75-77	<b>12-1061/3</b> (6)	<b>13-1017</b> (6)	<b>614-105</b> (4)	_____
		<b>12-1070</b> (1)	_____	_____	_____
CB550SC Nighthawk	1983	<b>12-1059</b> (6)	<b>13-1017</b> (5)	<b>614-142</b> (5)	_____
CB600F (519)	2004	<b>12-1042/2</b> (7)	<b>13-1031</b> (7)	_____ (5)	_____
		<b>12-1034</b> (1)	_____	_____	_____
CB600F (519)	2006	<b>12-1042/2</b> (7)	<b>13-1031</b> (7)	_____ (5)	_____
		<b>12-1034</b> (1)	_____	_____	_____
CBR600F Hurricane	87-90	<b>12-1059</b> (5)	<b>13-1017</b> (5)	<b>614-110</b> (4)	<b>643-1070</b>
		<b>12-1061/2</b> (1)	_____	_____	_____
CBR600F2 Hurricane	91-94	<b>12-1042/2</b> (8)	<b>13-1012</b> (8)	_____ (4)	<b>643-1083</b>
		<b>12-1034</b> (1)	_____	_____	_____
CBR600F3 Hurricane	95-98	<b>12-1042/2</b> (8)	<b>13-1012</b> (8)	_____ (4)	<b>643-1083</b>
		<b>12-1034</b> (1)	_____	_____	_____
CBR600F4 Hurricane	99-00	<b>12-1042/2</b> (7)	<b>13-1012</b> (6)	_____ (5)	_____
CBR600RR	03-06	<b>12-1042/2</b> (7)	<b>13-1031</b> (7)	_____ (5)	_____
		<b>12-1034</b> (1)	_____	_____	_____
CBR600SE	1998	<b>12-1042/2</b> (8)	<b>13-1012</b> (8)	_____ (4)	<b>643-1083</b>
		<b>12-1034</b> (1)	_____	_____	_____
CBR600SJR Replica	1996	<b>12-1042/2</b> (8)	<b>13-1012</b> (8)	_____ (4)	<b>643-1083</b>
		<b>12-1034</b> (1)	_____	_____	_____
VT600C Shadow	1988	<b>12-1042/2</b> (6)	<b>13-1047</b> (6)	_____ (4)	<b>643-1071</b>
		<b>12-1034</b> (1)	_____	_____	_____
VT600C Shadow	1989	<b>12-1042</b> (7)	<b>13-1046</b> (7)	_____ (4)	<b>643-1071</b>
		<b>12-1034</b> (1)	_____	_____	_____
VT600C Shadow	91-97	<b>12-1042/2</b> (6)	<b>13-1013</b> (6)	_____ (4)	<b>643-1071</b>
		<b>12-1034</b> (1)	_____	_____	_____
VT600C Shadow	99-06	<b>12-1042/2</b> (6)	<b>13-1013</b> (6)	_____ (4)	<b>643-1071</b>
		<b>12-1034</b> (1)	_____	_____	_____
VT600CD Shadow Deluxe	93-07	<b>12-1042/2</b> (6)	<b>13-1013</b> (6)	_____ (4)	<b>643-1071</b>
		<b>12-1034</b> (1)	_____	_____	_____
VT600CD2 Shadow Deluxe	99-00	<b>12-1042/2</b> (6)	<b>13-1013</b> (6)	_____ (4)	<b>643-1071</b>
		<b>12-1034</b> (1)	_____	_____	_____
XL600R	83-87	<b>12-1054</b> (7)	<b>13-1015</b> (6)	<b>614-126</b> (4)	<b>643-1028</b>
XL600V Transalp	89-90	<b>12-1042/2</b> (6)	<b>13-1013</b> (6)	_____ (4)	_____
		<b>12-1034</b> (1)	_____	_____	_____
CB650	79-82	<b>12-1061/3</b> (7)	<b>13-1025</b> (7)	<b>614-105</b> (4)	_____
		<b>12-1070</b> (1)	_____	_____	_____

## Honda Street

Model	Year	Friction Plate each	Drive(Metal) Plate each	Spring Set	Gasket each
CB650C Custom	80-81	<b>12-1061/3</b> (7)	<b>13-1025</b> (7)	<b>614-105</b> (4)	_____
		<b>12-1070</b> (1)	_____	_____	_____
CB650SC Nighthawk	1982	<b>12-1061/3</b> (7)	<b>13-1025</b> (7)	<b>614-105</b> (4)	_____
		<b>12-1070</b> (1)	_____	_____	_____
CB650SC Nighthawk	83-85	<b>12-1059</b> (6)	<b>13-1017</b> (5)	<b>614-142</b> (5)	_____
CX650C	1983	<b>12-1067</b> (7)	<b>13-1025</b> (6)	_____ (4)	_____
		<b>12-1074</b> (1)	<b>13-1039</b> (1)	_____	_____
CX650T Turbo	1983	<b>12-1067</b> (7)	<b>13-1027</b> (6)	<b>614-144</b> (6)	_____
		<b>12-1074</b> (1)	<b>13-1041</b> (1)	_____	_____
GL650 Silverwing	1983	<b>12-1061/3</b> (7)	<b>13-1025</b> (6)	_____ (4)	_____
		<b>12-1070</b> (1)	<b>13-1039</b> (1)	_____	_____
GL650I Silverwing Interstate	1983	<b>12-1061/3</b> (7)	<b>13-1025</b> (6)	_____ (4)	_____
		<b>12-1070</b> (1)	<b>13-1039</b> (1)	_____	_____
NT650 Hawk GT	88-89	<b>12-1042</b> (7)	<b>13-1046</b> (7)	_____ (4)	<b>643-1071</b>
		<b>12-1034</b> (1)	_____	_____	_____
NT650 Hawk GT	90-91	<b>12-1042</b> (7)	<b>13-1035</b> (7)	_____ (4)	<b>643-1071</b>
		<b>12-1034</b> (1)	_____	_____	_____
NX650	88-89	<b>12-1054</b> (7)	<b>13-1015</b> (6)	<b>614-151</b> (4)	<b>643-1028</b>
XR650L Dual Sport	93-06	<b>12-1061/4</b> (7)	<b>13-1015</b> (6)	<b>614-151</b> (4)	<b>643-1028</b>
CB700SC Nighthawk	84-86	<b>12-1061</b> (6)	<b>13-1023</b> (5)	<b>614-142</b> (5)	<b>643-1050</b>
VF700C Magna	84-87	<b>12-1061</b> (6)	<b>13-1023</b> (5)	<b>614-142</b> (5)	<b>643-1021</b>
VF700F Interceptor	84-85	<b>12-1054</b> (7)	<b>13-1023</b> (6)	<b>614-142</b> (5)	<b>643-1021</b>
VF700S Sabre	84-85	<b>12-1061</b> (6)	<b>13-1023</b> (5)	<b>614-142</b> (5)	<b>643-1021</b>
VFR700F Interceptor	1986	<b>12-1042/2</b> (8)	<b>13-1012</b> (8)	<b>614-159</b> (5)	<b>643-1064</b>
		<b>12-1034</b> (1)	_____	_____	_____
VFR700F2 Interceptor	86-87	<b>12-1042/2</b> (8)	<b>13-1012</b> (8)	<b>614-159</b> (5)	<b>643-1064</b>
		<b>12-1034</b> (1)	_____	_____	_____
VT700C Shadow	84-86	<b>12-1061</b> (6)	<b>13-1023</b> (5)	_____	<b>643-1040(I)</b>
VT700C Shadow	1987	<b>12-1061</b> (6)	<b>13-1023</b> (5)	<b>614-142</b> (5)	<b>643-1040(I)</b>
CB750 Nighthawk	91-93	<b>12-1059</b> (6)	<b>13-1017</b> (5)	<b>614-110</b> (4)	<b>643-1050</b>
		<b>12-1061/2</b> (1)	_____ (1)	_____	_____
CB750 Nighthawk	95-03	<b>12-1059</b> (6)	<b>13-1017</b> (5)	<b>614-110</b> (4)	<b>643-1050</b>
		<b>12-1061/2</b> (1)	_____ (1)	_____	_____
CB750C Custom	80-82	<b>12-1045</b> (7)	<b>13-1029</b> (6)	<b>614-145</b> (6)	<b>643-1002</b>
		<b>12-1073</b> (1)	<b>13-1040</b> (1)	_____	_____
CB750F Super Sport	75-76	<b>12-1033</b> (6)	<b>13-1023</b> (6)	<b>614-102</b> (4)	_____
		<b>12-1070</b> (1)	_____	_____	_____
CB750F Super Sport	77-78	<b>12-1033</b> (6)	<b>13-1023</b> (6)	<b>614-104</b> (4)	_____
		<b>12-1070</b> (1)	_____	_____	_____
CB750F Super Sport	79-82	<b>12-1045</b> (7)	<b>13-1029</b> (6)	<b>614-145</b> (6)	<b>643-1002</b>
		<b>12-1073</b> (1)	<b>13-1040</b> (1)	_____	_____
CB750K	79-82	<b>12-1045</b> (7)	<b>13-1029</b> (6)	<b>614-145</b> (6)	<b>643-1002</b>
		<b>12-1073</b> (1)	<b>13-1040</b> (1)	_____	_____
CB750L LTD	1979	<b>12-1045</b> (7)	<b>13-1029</b> (6)	<b>614-145</b> (6)	<b>643-1002</b>
		<b>12-1073</b> (1)	<b>13-1040</b> (1)	_____	_____
CB750SC Nighthawk	82-83	<b>12-1045</b> (7)	<b>13-1029</b> (6)	<b>614-145</b> (6)	<b>643-1002</b>
		<b>12-1073</b> (1)	<b>13-1040</b> (1)	_____	_____
VF750C V45 Magna	82-83	<b>12-1061</b> (6)	<b>13-1023</b> (5)	_____ (5)	<b>643-1021</b>
VF750C V45 Magna	1988	<b>12-1061</b> (6)	<b>13-1023</b> (5)	_____ (5)	<b>643-1021</b>
VF750C Magna	94-03	<b>12-1042/2</b> (8)	<b>13-1012</b> (8)	_____ (5)	<b>643-1064</b>
		<b>12-1034</b> (1)	_____	_____	_____
VF750C2 Magna Deluxe	97-00	<b>12-1042/2</b> (8)	<b>13-1012</b> (8)	_____ (5)	<b>643-1064</b>
		<b>12-1034</b> (1)	_____	_____	_____
VF750CD Magna Deluxe	95-96	<b>12-1042/2</b> (8)	<b>13-1012</b> (8)	_____ (5)	<b>643-1064</b>
		<b>12-1034</b> (1)	_____	_____	_____
VF750F V45 Interceptor	83-84	<b>12-1061</b> (7)	<b>13-1023</b> (6)	_____	<b>643-1021</b>
VF750S V45 Sabre	82-83	<b>12-1061</b> (6)	<b>13-1023</b> (5)	_____	<b>643-1021</b>
VFR750F Interceptor	1986	<b>12-1042/2</b> (8)	<b>13-1012</b> (8)	_____ (5)	_____
		<b>12-1034</b> (1)	_____	_____	_____
VFR750F	90-97	<b>12-1042/2</b> (8)	<b>13-1012</b> (8)	_____ (5)	_____
		<b>12-1034</b> (1)	_____	_____	_____
VT750C Shadow	1983	<b>12-1061</b> (6)	<b>13-1023</b> (5)	_____	<b>643-1040</b>
VT750C Shadow	98-00	<b>12-1042</b> (7)	<b>13-1035</b> (7)	_____ (4)	_____
		<b>12-1034</b> (1)	_____	_____	_____
VT750C Shadow Aero	04-06	<b>12-1042</b> (7)	<b>13-1035</b> (7)	_____	_____
		<b>12-1034</b> (1)	_____	_____	_____
VT750CA Shadow Aero	04-06	<b>12-1042</b> (7)	<b>13-1035</b> (7)	_____	_____
		<b>12-1034</b> (1)	_____	_____	_____
VT750CD Shadow Deluxe	98-01	<b>12-1042</b> (7)	<b>13-1035</b> (7)	_____ (4)	<b>643-1071</b>
		<b>12-1034</b> (1)	_____	_____	_____



# Clutch Plates, Clutch Springs, & Clutch Cover Gasket

## Honda Street

Model	Year	Friction Plate each	Drive(Metal) Plate each	Spring Set	Gasket each
VT750CD2 Shadow Deluxe	98-01	12-1042 (7) 12-1034 (1)	13-1035 (7)	(4)	643-1071
VT750CDA Shadow ACE	02-03	12-1042 (7) 12-1034 (1)	13-1035 (7)	(4)	
VT750CDB Shadow ACE	02-03	12-1042 (7) 12-1034 (1)	13-1035 (7)	(4)	
VT750CDC Shadow ACE	02-03	12-1042 (7) 12-1034 (1)	13-1035 (7)	(4)	
VT750CDD Shadow ACE	02-03	12-1042 (7) 12-1034 (1)	13-1035 (7)	(4)	
PC800 Pacific Coast	89-90	12-1061 (7)	13-1036 (6)	(5)	643-1040
PC800 Pacific Coast	94-98	12-1061 (7)	13-1036 (6)	(5)	643-1040
VFR800 Interceptor	02-06	12-1042/2 (7) 12-1034 (1)	13-1031 (7)	(5)	
VFR800A Interceptor (ABS)	02-06	12-1042/2 (7) 12-1034 (1)	13-1031 (7)	(5)	
VFR800FI Interceptor	98-99	12-1042/2 (8) 12-1034 (1)	13-1012 (8)	(5)	
VFR800FI Interceptor	00-01	12-1042/2 (8) 12-1034 (1)	13-1031 (7)	(5)	
VT800C Shadow	1988	12-1061 (6)	13-1023 (5)	614-155 (5)	643-1040
CB900C Custom	80-82	12-1045 (7) 12-1073 (1)	13-1029 (6) 13-1040 (1)	614-111 (6)	643-1002
CB900F Super Sport	81-82	12-1045 (7) 12-1073 (1)	13-1029 (6) 13-1040 (1)	614-111 (6)	643-1002
CB900F (919)	02-03	12-1042/2 (7) 12-1034 (1)	13-1031 (7)	(5)	643-1083
CBR900RR	93-95	12-1042/2 (8) 12-1034 (1)	13-1038 (8)	(5)	643-1083
CBR900RR	96-97	12-1042 (9) 12-1034 (1)	13-1031 (9)	(5)	643-1083
CBR900RR	98-99	12-1042/2 (7) 12-1034 (1)	13-1031 (7)	(5)	643-1083
CBR929RE	2001	12-1042/2 (8) 12-1034 (1)	13-1038 (8)	(5)	
CBR929RR	00-01	12-1042/2 (8) 12-1034 (1)	13-1038 (8)	(5)	
CBR954RR	02-03	12-1042/2 (8) 12-1034 (1)	13-1038 (8)	(5)	
CB1000	94-95	12-1061 (8) 12-1061/2 (1)	13-1017 (8)	(5)	
CB1000C Custom	1983	12-1045 (7) 12-1073 (1)	13-1029 (6)	614-141 (6)	643-1002
CBR1000F Hurricane	87-88	12-1061 (8) 12-1061/2 (1)	13-1017 (8)	(5)	643-1077
CBR1000F Hurricane	90-91	12-1061 (8) 12-1061/2 (1)	13-1017 (8)	(5)	643-1077
CBR1000F Hurricane	93-95	12-1061 (8) 12-1061/2 (1)	13-1017 (8)	(5)	
CBR1000RR	04-06	12-1059 (6) 12-1061 (2)	13-1050 (6)	(1)	(5)
CBR1000RR1	2005	12-1059 (6) 12-1061 (2)	13-1050 (6)	(1)	(5)
GL1000 Goldwing	75-79	12-1070 (7) 12-1033 (1)	13-1023 (6) 13-1027 (1)	614-144 (6)	643-1039
GL1000L Goldwing LTD	1976	12-1070 (7) 12-1033 (1)	13-1023 (6) 13-1027 (1)	614-144 (6)	643-1039
RVT1000R (RC51)	00-01	(7)	13-1032 (6)	(6)	
RVT1000R (RC51)	02-06	(6) (1)	13-1032 (6)	(6)	
VF1000F Interceptor	1984	12-1061 (9)	13-1023 (8)		643-1021
VF1000R	85-86	12-1061 (9)	13-1023 (8)		643-1021
VTR1000 Super Hawk	98-05	12-1061 (10)	13-1017 (9)	(5)	
ST1100	91-02	12-1061 (8) 12-1061/2-(2)	13-1017 (9)	614-155 (5)	643-1090
ST1100A (ABS)	92-02	12-1061 (8) 12-1061/2-(2)	13-1017 (9)	614-155 (5)	643-1090
GL1200A Aspencade	84-85	12-1067 (9)	13-1027 (7) 13-1042 (1)		643-1066
GL1200A Aspencade	86-87	12-1079 (9)	13-1027 (7) 13-1043 (1)		643-1066

## Honda Street

Model	Year	Friction Plate each	Drive(Metal) Plate each	Spring Set	Gasket each
GL1200I Interstate	84-85	12-1067 (9)	13-1027 (7) 13-1042 (1)		643-1066
GL1200I Interstate	86-87	12-1079 (9)	13-1042 (7) 13-1043 (1)		643-1066
GL1200L Goldwing LTD	1985	12-1067 (9)	13-1027 (7) 13-1042 (1)		643-1066
GL1200SEi Goldwing	1986	12-1079 (9)	13-1027 (7) 13-1043 (1)		643-1066
GL1500 Goldwing	88-89	12-1045 (9) 12-1073 (1)	13-1034 (8) 13-1044 (1)		643-1081
GL1500 Goldwing	1990	12-1045 (7) 12-1073 (1)	13-1034 (8) 13-1044 (1)		643-1081
GL1500A Aspencade	91-96	12-1045 (7) 12-1073 (1)	13-1034 (8) 13-1044 (1)		643-1081
GL1500A Aspencade	97-00	(8) (1)	13-1034 (8) 13-1045 (1)		643-1081
GL1500C Valkyrie	97-00	(8)	13-1034 (8) 13-1045 (1)		643-1081
GL1500C Valkyrie	2003	(8)	13-1034 (8) 13-1045 (1)		643-1081
GL1500CD Valkyrie	01-03	(8)	13-1034 (8) 13-1045 (1)		643-1081
GL1500CF Interstate	99-01	(8) (1)	13-1034 (8) 13-1045 (1)		643-1081
GL1500CT Valkyrie Tourer	97-00	(8) (1)	13-1034 (8) 13-1045 (1)		643-1081
GL1500I Goldwing Interstate	91-96	12-1045 (7) 12-1073 (1)	13-1034 (8) 13-1044 (1)		643-1081
GL1500SE Goldwing SE	90-96	12-1045 (7) 12-1073 (1)	13-1034 (8) 13-1044 (1)		643-1081
GL1500SE	97-00	(8) (1)	13-1034 (8) 13-1045 (1)		643-1081

## Honda ATV

Model	Year	Friction Plate each	Drive(Metal) Plate each	Spring Set	Gasket each
ATC70/K1	73-74	12-1011 (2) 12-1077 (1)	13-1020 (1) 13-1001 (1)	614-115 (4)	
ATC70	78-85	12-1011 (2) 12-1077 (1)	13-1020 (1) 13-1001 (1)	614-115 (4)	
TRX70 Fourtrax 70	86-87	12-1011 (2) 12-1077 (1)	13-1020 (1) 13-1001 (1)	614-115 (4)	
ATC90/K1/K2/K3	70-75	12-1017 (3)	13-1001 (1) 13-1002 (1) 13-1003 (1)	614-118 (4)	
ATC90	76-78	12-1017 (3)	13-1001 (1) 13-1002 (1) 13-1003 (1)	614-118 (4)	
TRX90 Fourtrax 90	93-01	12-1019 (4)	13-1004 (3)	614-139 (4)	
TRX90 Sportrax 90	02-05	12-1019 (4)	13-1004 (3)	614-139 (4)	
TRX90 Sportrax 90	2006	12-1019 (4)	13-1004 (3)	614-143 (4)	
ATC110	79-80	12-1017 (3)	13-1001 (1) 13-1002 (1) 13-1003 (1)	614-132 (4)	643-1023
ATC110	81-85	12-1017 (3)	13-1001 (1) 13-1002 (1) 13-1003 (1)	614-118 (4)	643-1023
ATC125M	84-85	12-1017 (3)	13-1001 (1) 13-1002 (1) 13-1003 (1)	614-118 (4)	643-1023
ATC125M	86-87	12-1019 (4)	13-1004 (3)	614-118 (4)	
TRX125 Fourtrax	1985	12-1017 (3)	13-1001 (1) 13-1002 (1) 13-1003 (1)	614-118 (4)	643-1023
TRX125 Fourtrax	1986	12-1017 (3)	13-1001 (1) 13-1002 (1) 13-1003 (1)	614-118 (4)	
TRX125 Fourtrax	87-88	12-1019 (4)	13-1004 (3)	614-139 (4)	
ATC185	1980	12-1019 (4)	13-1004 (3)	614-117 (4)	643-1016

# Clutch Plates, Clutch Springs, & Clutch Cover Gasket

## Honda ATV

Model	Year	Friction Plate each	Drive(Metal) Plate each	Spring Set	Gasket each
ATC185S	81-83	12-1019 (4)	13-1004 (3)	614-117 (4)	643-1016
ATC200	81-83	12-1019 (4)	13-1004 (3)	614-117 (4)	643-1016
ATC200E	82-83	12-1019 (4)	13-1004 (3)	614-117 (4)	643-1016
ATC200ES	1984	12-1019 (4)	13-1004 (3)	614-117 (4)	643-1016
ATC200M	84-85	12-1019 (4)	13-1004 (3)	614-117 (4)	643-1016
ATC200S	84-86	12-1019 (4)	13-1004 (3)	614-117 (4)	643-1016
ATC200X	83-85	12-1019 (5)	13-1004 (4)	614-105 (4)	643-1016
ATC200X	86-87	12-1019 (5)	13-1004 (4)	614-105 (4)	643-1059
TRX200 Fourtrax 200	1984	12-1019 (4)	13-1004 (3)	614-117 (4)	643-1016
TRX200 Fourtrax 200	90-91	12-1019 (5)	13-1006 (4)	614-148 (4)	——
TRX200D Fourtrax Type II	91-97	12-1019 (5)	13-1006 (4)	614-148 (4)	——
TRX200SX Fourtrax	86-88	12-1019 (5)	13-1006 (4)	614-148 (4)	——
ATC250ES	85-87	12-1042 (5)	13-1011 (4)	614-143 (4)	——
ATC250R	81-84	12-1046 (7)	13-1046 (6)	614-116 (6)	——
ATC250R	1985	12-1042/2 (7)	13-1011 (6)	614-142 (5)	643-1030
ATC250R	1986	12-1042/2 (7)	13-1011 (6)	614-142 (5)	643-1030
ATC250SX	85-87	12-1042 (5)	13-1011 (4)	612-143 (4)	——
TRX250 Fourtrax 250	85-87	12-1042 (5)	13-1011 (4)	612-143 (4)	——
TRX250 Recon	97-01	12-1019 (5)	13-1006 (4)	614-148 (4)	——
TRX250EX Sportrax 250EX 01-02	12-1019 (5)	13-1006 (4)	614-148 (4)	——	——
TRX250EX Sportrax 250EX 03-05	12-1019 (5)	13-1006 (4)	614-148 (4)	——	——
TRX250R Fourtrax 250R	86-87	12-1042/2 (7)	13-1011 (6)	614-142 (5)	643-1030
TRX250R Fourtrax 250R	88-89	12-1042/2 (7)	13-1011 (6)	614-142 (5)	643-1030
TRX250TE Recon ES	02-06	12-1019 (5)	13-1006 (4)	614-148 (4)	——
TRX250TM Fourtrax Recon	02-06	12-1019 (5)	13-1006 (4)	614-148 (4)	——
TRX250X Fourtrax 250X	87-88	12-1042/2 (6)	13-1011 (5)	614-127 (4)	——
TRX250X Fourtrax 250X	91-92	12-1042/2 (6)	13-1011 (5)	614-127 (4)	——
TRX300 Fourtrax 300	88-00	12-1042 (6)	13-1011 (5)	614-147 (4)	643-1072
TRX300EX Sportrax 300EX 03-05	12-1042/2 (6)	13-1011 (5)	614-127 (4)	643-1087	——
TRX300EX Sportrax 300EX 01-05	12-1042/2 (6)	13-1011 (5)	614-127 (4)	643-1087	——
TRX300FW Fourtrax 4x4	1988	12-1042 (6)	13-1011 (5)	614-147 (4)	643-1072
TRX300FW Fourtrax 4x4	90-00	12-1042 (6)	13-1011 (5)	614-147 (4)	643-1072
ATC350X	85-86	12-1042/2 (6)	13-1011 (5)	614-146 (4)	——
TRX350 Fourtrax 4x4	86-87	12-1042 (6)	13-1011 (5)	614-147 (4)	——
TRX350D Foreman 4x4	87-89	12-1042 (6)	13-1011 (5)	614-147 (4)	——
TRX350FE Rancher 4x4 ES	00-06	12-1042 (5)	13-1011 (5)	614-147 (4)	——
		12-1034 (1)	——	——	——
TRX350FM Rancher 4x4	00-06	12-1042 (6)	13-1011 (5)	614-147 (4)	——
TRX350TE Rancher ES	00-06	12-1042 (5)	13-1011 (5)	614-147 (4)	——
		12-1034 (1)	——	——	——
TRX350TM Rancher	00-06	12-1042 (6)	13-1011 (5)	614-147 (4)	——
TRX400EX Fourtrax 400EX 99-00	12-1042/2 (7)	13-1048 (6)	——	(5)	643-1088
TRX400EX Sportrax 400EX 01-04	12-1042/2 (7)	13-1048 (6)	——	(5)	643-1088
TRX400EX Sportrax 400EX 2005	12-1042/2 (7)	13-1048 (6)	——	(5)	643-1088
TRX400FW Foreman	95-01	12-1042 (6)	13-1011 (5)	614-147 (4)	——
TRX400FW Foreman	2003	12-1042 (6)	13-1049 (5)	614-147 (4)	——
TRX450ES Foreman	98-01	12-1042 (6)	13-1011 (5)	614-147 (4)	——
TRX450FE Foreman ES	02-04	12-1042 (6)	13-1049 (5)	614-147 (4)	——
TRX450FM Foreman S	02-04	12-1042 (6)	13-1049 (5)	614-147 (4)	——
TRX450R	04-05	12-1054 (7)	13-1019 (7)	614-122 (5)	——
		(1)	——	——	——
TRX450S Foreman	98-01	12-1042 (6)	13-1011 (5)	614-147 (4)	——
TRX500FE Foreman S	05-06	12-1042 (7)	13-1049 (6)	——	(5)
TRX500FM Foreman 4x4	05-06	12-1042 (7)	13-1049 (6)	——	(5)
TRX500TM Foreman	05-06	12-1042 (7)	13-1049 (6)	——	(5)

## Honda Dual Sport & Offroad

Model	Year	Friction Plate each	Drive(Metal) Plate each	Spring Set	Gasket each
CRF50F	04-07	12-1011 (2)	13-1001 (1)	——	(4) 643-1020
		12-1077 (1)	13-1020 (1)	——	——
QA50K0-K3	70-75	12-1012 (2)	——	(3)	614-136 (4)
XR50R	00-03	12-1011 (2)	13-1001 (1)	——	(4) 643-1020
		12-1077 (1)	13-1020 (1)	——	——
Z50AKO	68-69	12-1012 (2)	——	(3)	614-136 (4)
Z50A	76-78	12-1012 (2)	——	(3)	614-136 (4)
Z50AK1-AK6 Mini Trail 50	69-75	12-1012 (2)	——	(3)	614-136 (4)
Z50R	79-87	12-1012 (2)	——	(3)	614-136 (4)
Z50R	88-89	12-1011 (2)	——	(3)	——
Z50RD	1986	12-1012 (2)	——	(3)	614-136 (4)
Z50R	91-99	12-1011 (2)	13-1001 (1)	——	(4)
		12-1077 (1)	13-1020 (1)	——	——

## Honda Dual Sport & Offroad

Model	Year	Friction Plate each	Drive(Metal) Plate each	Spring Set	Gasket each
CR60R	83-84	12-1019 (4)	13-1005 (3)	614-131 (4)	——
CRF70F	04-07	12-1011 (2)	13-1001 (1)	614-115 (4)	643-1020
		12-1077 (1)	13-1020 (1)	——	——
CT70	76-82	12-1011 (2)	13-1001 (1)	614-115 (4)	——
		12-1077 (1)	13-1020 (1)	——	——
CT70K0/K1 Trail 70	69-72	12-1012 (2)	13-1001 (3)	614-115 (4)	——
CT70H Trail 70	70-73	12-1012 (2)	13-1001 (3)	614-115 (4)	——
CT70K2-K4 Trail 70	73-75	12-1011 (2)	13-1001 (3)	614-115 (4)	——
SL70K0/K1 Moto Sport	71-73	12-1012 (2)	——	(2)	(4)
XR70R	97-03	12-1011 (2)	13-1001 (1)	614-115 (4)	643-1020
		12-1077 (1)	13-1020 (1)	——	——
XL75	77-79	12-1019 (3)	13-1005 (2)	614-129 (4)	643-1026
XR75K0/K1/K2	73-75	12-1019 (3)	13-1005 (2)	614-138 (4)	——
XR75	1976	12-1019 (3)	13-1005 (2)	614-138 (4)	——
XR75	77-78	12-1019 (3)	13-1005 (2)	614-129 (4)	643-1026
CR80R	80-82	12-1019 (4)	13-1005 (3)	614-131 (4)	——
CR80R	1983	12-1019 (4)	13-1005 (3)	614-139 (4)	——
CR80R	1984	12-1019 (5)	13-1007 (4)	614-139 (4)	643-1037
CR80R	1985	12-1019 (5)	13-1007 (4)	614-149 (4)	643-1037
CR80R	1986	12-1019 (5)	13-1007 (4)	614-149 (4)	643-1053
CR80R	87-02	12-1019 (5)	13-1005 (4)	614-149 (4)	643-1053
CR80RB	96-02	12-1019 (5)	13-1005 (4)	614-149 (4)	643-1053
CRF80F	2004	12-1019 (3)	13-1005 (2)	614-147 (4)	643-1026
CRF80F	05-07	12-1019 (3)	13-1005 (2)	614-139 (4)	643-1026
XL80S	80-85	12-1019 (3)	13-1005 (2)	614-129 (4)	643-1026
XR80	79-84	12-1019 (3)	13-1005 (2)	614-129 (4)	643-1026
XR80R	85-88	12-1019 (3)	13-1005 (2)	614-139 (4)	643-1026
XR80R	90-91	12-1019 (3)	13-1005 (2)	614-139 (4)	643-1026
XR80R	93-03	12-1019 (3)	13-1005 (2)	614-139 (4)	643-1026
CR85R	03-07	12-1019 (5)	13-1005 (4)	614-149 (4)	643-1053
CR85RB	03-07	12-1019 (5)	13-1005 (4)	614-149 (4)	643-1053
CT90K1-K6 Trail 90	69-75	12-1017 (3)	——	(4)	(4)
CT90 Trail 90	76-79	12-1017 (3)	——	(4)	(4)
ST90/K1/K2 Trail Sport 90	73-75	12-1017 (3)	——	(4)	(4)
SL100K0-K3 Motosport	70-73	12-1019 (5)	13-1005 (4)	614-101 (4)	——
CRF100F	04-07	12-1019 (4)	13-1005 (3)	614-147 (4)	643-1026
XL100/K1	74-75	12-1019 (5)	13-1005 (4)	614-101 (4)	643-1018
XL100	76-78	12-1019 (5)	13-1005 (4)	614-101 (4)	643-1018
XL100S	79-80	12-1019 (4)	13-1005 (3)	614-138 (4)	643-1026
XL100S	81-85	12-1019 (4)	13-1005 (3)	614-129 (4)	643-1026
XR100	81-84	12-1019 (4)	13-1005 (3)	614-129 (4)	643-1026
XR100R	85-86	12-1019 (4)	13-1005 (3)	614-129 (4)	643-1026
XR100R	87-03	12-1019 (4)	13-1005 (3)	614-147 (4)	643-1026
CT110 Trail 110	80-84	12-1017 (3)	——	(4)	614-132 (4) 643-1023
CT110 Trail 110	1986	12-1017 (3)	——	(4)	614-132 (4) 643-1023
CR125M Elsinore	74-78	12-1019/2 (6)	13-1009 (5)	——	(4)
CR125R	79-80	12-1047 (6)	13-1009 (5)	614-119 (4)	——
CR125R	1981	12-1019 (6)	13-1009 (5)	614-119 (4)	——
CR125R	1982	12-1019 (7)	——	(6)	614-119 (4)
CR125R	1983	12-1042/2 (6)	——	(5)	614-133 (5)
CR125R	84-85	12-1042/2 (6)	——	(5)	614-133 (5) 643-1043
CR125R	1986	12-1087 (7)	——	(6)	614-133 (5) 643-1043
CR125R	87-89	12-1087 (7)	——	(6)	614-133 (5)
CR125R	90-99	12-1087 (7)	——	(6)	614-133 (5) 643-1074
CR125R	00-07	12-1087 (8)	——	(7)	614-133 (5) 643-1074
CT125 Trail 125	1977	12-1019 (5)	13-1005 (4)	614-101 (4)	——
NX125	88-90	12-1019 (4)	13-1005 (4)	614-109 (4)	——
		12-1068 (1)	——	——	——
SL125/K1/K2	71-73	12-1019 (5)	13-1005 (4)	614-101 (4)	——
TL125/K1/K2 Trials	73-75	12-1019 (4)	13-1005 (3)	614-101 (4)	——
TL125S Trials	1976	12-1019 (5)	13-1005 (4)	614-101 (4)	——
XL125/K1	74-75	12-1019 (5)	13-1005 (4)	614-101 (4)	——
XL125	76-78	12-1019 (5)	13-1005 (4)	614-101 (4)	——
XL125S	79-82	12-1019 (5)	13-1005 (4)	614-137 (4)	643-1078
XL125S	84-85	12-1019 (5)	13-1005 (4)	614-137 (4)	643-1078
SL175/K1 Motosport	70-72	12-1034 (5)	13-1046 (4)	——	(4)
XL175/K1/K2	73-75	12-1034 (5)	13-1046 (4)	——	(4)
XL175	76-78	12-1034 (5)	13-1046 (4)	——	(4)
XL185S	79-83	12-1019 (5)	13-1005 (4)	614-101 (4)	643-1078
XR185	1979	12-1019 (5)	13-1005 (4)	614-101 (4)	643-1078
TLR200 Reflex	86-87	12-1019 (5)	13-1005 (4)	614-154 (4)	643-1078



# Clutch Plates, Clutch Springs, & Clutch Cover Gasket

## Honda Dual Sport & Offroad

Model	Year	Friction Plate each	Drive(Metal) Plate each	Spring Set	Gasket each
TR200 Fatcat	1986	12-1019 (5)	13-1006 (4)	614-148 (4)	643-1059
XL200R	83-84	12-1019 (5)	13-1005 (4)	614-105 (4)	643-1078
XR200	80-84	12-1019 (5)	13-1005 (4)	614-150 (4)	643-1078
XR200R	81-83	12-1019 (5)	13-1005 (4)	614-150 (4)	643-1078
XR200R	84-85	12-1042/2 (5)	13-1011 (4)	614-105 (4)	643-1047
XR200R	86-88	12-1019 (5)	13-1005 (4)	614-105 (4)	643-1078
XR200R	90-91	12-1019 (5)	13-1005 (4)	614-105 (4)	643-1078
XR200R	1993	12-1019 (5)	13-1005 (4)	614-105 (4)	643-1078
XR200R	94-02	12-1019 (5)	13-1005 (4)	614-150 (4)	643-1078
CRF230F	03-07	12-1019 (5)	_____ (5)	_____ (4)	_____
		12-1068 (1)	_____	_____	_____
CR250M/M1 Elsinore	73-76	12-1061/3 (7)	13-1018 (6)	_____ (6)	_____
CR250R	78-80	12-1046 (7)	13-1046 (6)	614-116 (6)	_____
CR250R	81-82	12-1061/3 (7)	13-1046 (6)	614-134 (6)	_____
CR250R	1983	12-1054 (7)	_____ (6)	614-134 (6)	_____
CR250R	1984	12-1054 (7)	_____ (6)	614-134 (6)	_____
CR250R	85-87	12-1054 (7)	_____ (6)	614-134 (6)	643-1046
CR250R	88-89	12-1054 (7)	_____ (6)	614-134 (6)	_____
CR250R	90-91	12-1054 (8)	_____ (7)	614-134 (6)	_____
CR250R	92-96	12-1054 (8)	_____ (7)	614-134 (6)	643-1085
CR250R	97-01	12-1054 (8)	_____ (7)	614-122 (6)	643-1085
CR250R	02-04	12-1054 (8)	_____ (7)	614-122 (6)	_____
CR250R	05-07	12-1054 (8)	_____ (7)	614-122 (6)	_____
CRF250R	04-07	12-1087 (8)	13-1011 (7)	_____ (5)	_____
CRF250X	04-06	12-1087 (7)	13-1011 (7)	_____ (5)	_____
		_____ (1)	_____	_____	_____
MR250 Elsinore	1976	12-1061/3 (7)	13-1018 (6)	_____ (6)	_____
MT250/K1	74-75	12-1061/3 (7)	13-1018 (6)	_____ (6)	_____
NX250	88-90	12-1042/2 (6)	13-1011 (5)	614-152 (4)	_____
TL250 Trials	75-76	12-1061/3 (7)	13-1025 (6)	614-101 (4)	_____
XL250/K1/K2 Motosport	72-75	12-1061/3 (7)	13-1025 (6)	614-101 (4)	_____
XL250	1976	12-1061/3 (7)	13-1025 (6)	614-101 (4)	_____
XL250S	78-80	12-1042 (4)	13-1046 (3)	614-135 (4)	643-1009
XL250S	1981	12-1042 (4)	13-1046 (4)	614-135 (4)	643-1009
		12-1034 (1)	_____	_____	_____
XL250R	82-83	12-1042 (4)	13-1046 (4)	614-135 (4)	643-1009
		12-1034 (1)	_____	_____	_____
XL250R	84-87	12-1042/2 (5)	13-1011 (5)	614-127 (4)	643-1047
XR250	79-80	12-1042 (4)	13-1046 (3)	612-135 (4)	643-1009
XR250R	81-82	12-1042 (4)	13-1046 (4)	612-135 (4)	643-1009
		12-1034 (1)	_____	_____	_____
XR250R	84-85	12-1042/2 (5)	13-1011 (4)	614-127 (4)	643-1047
XR250R	86-95	12-1042/2 (6)	13-1011 (5)	614-127 (4)	643-1047
XR250R	96-04	12-1042/2 (6)	13-1011 (5)	614-127 (4)	643-1086
XR250L	91-96	12-1042/2 (6)	13-1011 (5)	614-127 (4)	643-1047
SL350/K1/K2 Moto Sport	70-73	12-1061/3 (8)	_____ (8)	614-102 (4)	643-1013
XL350/K1	74-75	12-1061/3 (7)	13-1025 (6)	_____ (4)	_____
XL350	76-78	12-1061/3 (7)	13-1025 (6)	_____ (4)	_____
XL350R	84-85	12-1042/2 (5)	13-1011 (5)	614-146 (4)	_____
		12-1034 (1)	_____	_____	_____
XR350R	83-84	12-1042/2 (6)	13-1011 (5)	614-127 (4)	_____
XR350R	1985	12-1042/2 (6)	13-1011 (5)	614-127 (4)	_____
XR400R	96-04	12-1042/2 (7)	13-1011 (6)	_____ (5)	643-1088
CR450R	1981	12-1061/3 (7)	13-1018 (6)	614-134 (6)	_____
CRF450R	02-03	12-1054 (8)	13-1019 (7)	614-122 (6)	_____
CRF450R	04-05	12-1054 (8)	13-1019 (7)	614-134 (6)	_____
CRF450R	06-07	12-1054 (8)	13-1019 (7)	614-122 (6)	_____
CRF450X	05-07	12-1054 (8)	13-1019 (7)	614-134 (6)	_____
CR480R	1982	12-1061/3 (7)	13-1018 (6)	614-134 (6)	_____
CR480R	1983	12-1054 (7)	_____ (6)	614-122 (6)	_____
CR500R	1984	12-1054 (7)	_____ (6)	614-122 (6)	_____
CR500R	85-89	12-1054 (7)	_____ (6)	614-122 (6)	643-1054
CR500R	90-01	12-1054 (8)	_____ (7)	614-122 (6)	643-1054
XL500S	79-81	12-1042 (6)	13-1014 (6)	614-107 (4)	643-1009
		12-1034 (1)	_____	_____	_____
XL500R	1982	12-1042 (6)	13-1014 (6)	614-107 (4)	643-1009
XR500	79-80	12-1042 (7)	13-1014 (6)	614-107 (4)	643-1009
XR500R	81-82	12-1042 (7)	13-1014 (6)	614-107 (4)	643-1009
XR500R	83-84	12-1054 (7)	13-1015 (6)	614-126 (4)	643-1028
XL600R	83-87	12-1054 (7)	13-1015 (6)	614-126 (4)	643-1028

## Honda Dual Sport & Offroad

Model	Year	Friction Plate each	Drive(Metal) Plate each	Spring Set	Gasket each
XL600V Transalp	89-90	12-1042/2 (6)	13-1013 (6)	_____ (4)	643-1071
		12-1034 (1)	_____	_____	_____
XR600R	85-00	12-1054 (7)	13-1015 (6)	614-151 (4)	643-1028
NX650	88-89	12-1054 (7)	13-1015 (6)	614-151 (4)	643-1028
XR650L Dual Sport	93-07	12-1061/4 (7)	13-1015 (6)	614-151 (4)	643-1028
XR650R	00-07	12-1059 (6)	13-1015 (6)	_____ (4)	_____
		_____ (1)	_____	_____	_____

## Kawasaki Street

Model	Year	Friction Plate each	Drive(Metal) Plate each	Spring Set	Gasket each
AR50A1	1982	12-4038 (3)	13-4012 (2)	614-416 (6)	_____
AR80A1	1982	12-4038 (4)	13-4012 (3)	614-416 (6)	_____
G3SS/A/B/C/D-90	69-74	12-4038 (4)	13-4012 (3)	614-417 (6)	_____
G3TR-90 Bushmaster	69-70	12-4038 (4)	13-4012 (3)	614-417 (6)	_____
MC1/MC1A/MC1B-90	73-75	12-4038 (4)	13-4012 (3)	614-417 (6)	_____
G3SSE-100	1975	12-4038 (4)	13-4012 (3)	614-417 (6)	_____
G3TRA-100 Bushmaster	1971	12-4038 (4)	13-4012 (3)	614-417 (6)	_____
G4TR-100 Trail Boss	1970	12-4038 (4)	13-4012 (3)	614-417 (6)	_____
G4TRA/B/C/D/E 100	71-75	12-4038 (4)	13-4012 (3)	614-417 (6)	_____
G5/G5A/B/C-100	72-75	12-4038 (4)	13-4012 (3)	614-417 (6)	_____
KE100A5-A10	76-81	12-4038 (4)	13-4012 (3)	614-417 (6)	_____
KE100B1-B20	82-01	12-4038 (4)	13-4012 (3)	614-417 (6)	_____
KH100B7/B8	76-77	12-4038 (4)	13-4012 (3)	614-417 (6)	_____
KM100A1-A7	76-81	12-4038 (4)	13-4012 (3)	614-417 (6)	_____
KV100A7	1976	12-4038 (4)	13-4012 (3)	614-417 (6)	_____
F6/A/B-125 Enduro	71-73	12-4041 (5)	13-4001 (4)	_____ (5)	_____
KS125/A	74-75	12-4041 (5)	13-4001 (4)	614-414 (5)	_____
KE125A3-A10	76-83	12-4041 (5)	13-4001 (4)	614-414 (5)	_____
F7A/B/C/D-175 Enduro	71-75	12-4041 (5)	13-4001 (5)	_____ (5)	_____
KE175B1/B2/B3	76-78	12-4041 (5)	13-4001 (4)	614-413 (6)	_____
KE175D2/D3/D4/D5	80-83	12-4041 (5)	13-4001 (4)	614-413 (6)	_____
KZ200A1/A2	78-79	12-4049 (5)	13-4002 (5)	614-406 (5)	_____
KZ200A1/A2 eng.005063 on	78-79	12-4049 (6)	13-4002 (5)	614-406 (5)	_____
EL250B2/B3 Eliminator	88-89	12-4040 (5)	13-4004 (4)	614-426 (4)	_____
EL250E1/E2/E3/E4 250HS	91-94	12-4040 (5)	13-4004 (4)	614-426 (4)	_____
EX250E1/E2 Ninja 250R	86-87	12-4040 (5)	13-4004 (4)	614-426 (4)	_____
EX250F2/F3/F4 Ninja 250R	88-90	12-4040 (5)	13-4004 (4)	614-426 (4)	_____
EX250F6-F19 Ninja 250R	92-05	12-4040 (5)	13-4004 (4)	614-426 (4)	_____
EX250F6F/F7F Ninja 250R	06-07	12-4040 (5)	13-4004 (4)	614-426 (4)	_____
KE250B1/B2/B3	77-79	12-1061/4 (6)	13-4008 (5)	614-415 (5)	_____
KH250A5 2-stroke triple	1976	12-4041 (6)	13-4001 (5)	_____ (5)	_____
KL250A1-A5	78-82	12-4049 (7)	13-4002 (6)	_____ (5)	_____
KL250C1/C2	83-84	12-4049 (7)	13-4002 (6)	614-406 (5)	_____
KL250D2-D22 KLR250	85-05	12-4049 (5)	13-4028 (5)	614-406 (5)	_____
KL250G4-G7 Super Sherpa	00-03	12-4058 (7)	13-4044 (5)	_____ (6)	_____
		_____	13-4038 (1)	_____	_____
KLX250H6F KLX250S	2006	12-4058 (7)	13-4044 (5)	_____ (6)	_____
		_____	13-4038 (1)	_____	_____
KZ250D1/D2 LTD & CSR	80-81	12-4049 (7)	13-4002 (6)	614-406 (5)	_____
KZ250L1 CSR	1982	12-4049 (7)	13-4002 (6)	614-406 (5)	_____
KZ250W1 LTD	1983	12-4049 (7)	13-4002 (6)	614-406 (5)	_____
S1A/S1B/S1C-250 triple	73-75	12-4041 (6)	13-4001 (5)	_____ (5)	_____
EX305B1 GPz	1983	12-1061/4 (7)	13-4008 (6)	614-411 (5)	_____
KZ305A1/A2 CSR	81-82	12-1061/4 (7)	13-4008 (6)	614-415 (5)	_____
KZ305B1 CSR Belt	1982	12-1061/4 (7)	13-4008 (6)	614-415 (5)	_____
KZ305B2/B3 LTD	87-88	12-1061/4 (7)	13-4008 (6)	614-415 (5)	_____
S2/S2A 350 2-stroke	72-73	12-4041 (6)	13-4001 (5)	_____ (5)	_____
KZ400A1/A2 Deluxe	77-78	_____ (6)	13-4004 (5)	614-408 (4)	_____
KZ400B1/B2	78-79	_____ (6)	13-4004 (5)	614-408 (4)	643-4025
KZ400C1	1978	_____ (6)	13-4004 (5)	614-408 (4)	643-4025
KZ400D/D3/D4	74-77	_____ (6)	13-4004 (5)	614-408 (4)	_____
KZ400H1 LTD	1979	_____ (6)	13-4004 (5)	614-408 (4)	643-4025
KZ400S/S2/S3 Special	75-77	_____ (6)	13-4004 (5)	614-408 (4)	_____
KH400A5 2-stroke triple	1976	12-4041 (7)	13-4001 (6)	_____ (5)	_____
		74-75 12-4041 (7)	13-4001 (6)	_____ (5)	_____
KZ440A1-A4 LTD	80-83	_____ (6)	13-4004 (5)	614-408 (4)	643-4025
KZ440B1/B2	80-81	_____ (6)	13-4004 (5)	614-408 (4)	643-4025
KZ440D1-D5 LTD Belt	80-83	_____ (6)	13-4004 (5)	614-408 (4)	643-4025
KZ440G1 Sport Belt	1983	_____ (6)	13-4004 (5)	614-408 (4)	643-4025
EN450A1-A6 Ltd 454	85-90	12-4040 (7)	13-4004 (6)	614-412 (5)	643-4039
EN500A1-A7 Vulcan 500	90-96	12-4040 (7)	13-4004 (6)	614-412 (5)	643-4039
EN500C1-C10 LTD	96-05	12-4040 (7)	13-4004 (6)	614-412 (5)	643-4039

Clutch Plates, Clutch Springs, & Clutch Cover Gasket

Kawasaki Street

Table with columns: Model, Year, Friction Plate each, Drive(Metal) Plate each, Spring Set, Gasket each. Lists parts for various Kawasaki models including Vulcan 500, Ninja 500, Ninja 600R, etc.

Kawasaki Street

Table with columns: Model, Year, Friction Plate each, Drive(Metal) Plate each, Spring Set, Gasket each. Lists parts for various Kawasaki models including GPz, Ninja ZX-7, Ninja ZX-7R, Ninja ZX-7RR, Ninja ZX-9R, etc.



# Clutch Plates, Clutch Springs, & Clutch Cover Gasket

## Kawasaki Street

Model	Year	Friction Plate each	Drive(Metal) Plate each	Spring Set	Gasket each
ZG1200B5-B17 Voyager XII	91-03	<b>12-4040</b> (9)	(6)	<b>614-405</b> (6)	<b>643-4051</b>
KZ1300A1/A2/A3	79-81	<b>12-4032</b> (9)	<b>13-4006</b> (8)	<b>614-401</b> (5)	
KZ1300A4	1982	<b>12-4032</b> (7)	<b>13-4006</b> (1)	<b>614-401</b> (5)	
KZ1300B2 Touring	1980	<b>12-4032</b> (9)	<b>13-4006</b> (8)	<b>614-401</b> (5)	
ZN1300A1-A6 Voyager	83-88	<b>12-4044</b> (8)	<b>13-4020</b> (6)	<b>614-401</b> (5)	
			<b>13-4019</b> (1)		
VN1500A1-A9 Vulcan 88	87-95	<b>12-4044</b> (8)	(7)	(10)	
VN1500A10-A13 Vulcan	96-99	<b>12-4044</b> (8)	(7)	(10)	
VN1500B1-B4 Vulcan 88 SE	87-90	<b>12-4044</b> (8)	(7)	(10)	
VN1500C3/C4 1500L	96-97	<b>12-4044</b> (8)	(7)	(10)	
VN1500D1-L5 Classic	96-97	<b>12-4044</b> (8)	(7)	(10)	
VN1500E1-E7 Classic	98-04	<b>12-4044</b> (8)	(7)	(10)	
VN1500G1-G3 Nomad	99-01	<b>12-4044</b> (8)	(7)	(10)	
VN1500J1/J2 Drifter	99-00	<b>12-4044</b> (8)	(7)	(10)	
VN1500L1-L5 Nomad F.I.	00-04	<b>12-4044</b> (8)	(7)	(10)	
VN1500N1-N3 Classic F.I.	00-02	<b>12-4044</b> (8)	(7)	(10)	
VN1500N4 Classic F.I.	2005	<b>12-4044</b> (8)	(7)	(10)	
VN1500N6F Vulcan Classic	2006	<b>12-4044</b> (8)	(7)	(10)	
VN1500P Mean Streak	02-03	<b>12-4044</b> (8)	(7)	(10)	
VN1500R1-R5 Drifter	00-05	<b>12-4044</b> (8)	(7)	(10)	
VN1500T6F Vulcan Classic	2006	<b>12-4044</b> (8)	(7)	(10)	
VN1600A1-A6F Classic	03-06	<b>12-4044</b> (8)	<b>13-4051</b> (7)	(10)	
VN1600B Mean Streak	04-05	<b>12-4044</b> (8)	<b>13-4051</b> (7)	(10)	
VN1600D1/D6F Nomad	05-06	<b>12-4044</b> (8)	<b>13-4051</b> (7)	(10)	
VN1600E6F	2006	<b>12-4044</b> (8)	<b>13-4051</b> (7)	(10)	
VN1600F6F	2006	<b>12-4044</b> (8)	<b>13-4051</b> (7)	(10)	
VN2000A1/A2 Vulcan 2000	04-05	<b>12-4044</b> (10)	<b>13-4051</b> (9)	(6)	
VN2000A6F Vulcan 2000	2006	<b>12-4044</b> (10)	<b>13-4051</b> (9)	(6)	
VN2000D1/D6F Limited	05-06	<b>12-4044</b> (10)	<b>13-4051</b> (9)	(6)	
VN2000D7F Classic LT	2007	<b>12-4044</b> (10)	<b>13-4051</b> (9)	(6)	

## Kawasaki ATV

KLF110A1/A2 Mojave 110	87-88	<b>12-1004</b> (3)	(4)	(4)	
KLF110B1/B2 Mojave 110	87-88	<b>12-1004</b> (3)	(4)	(4)	
KLT110A1/A2/A3	84-86	<b>12-1004</b> (3)	(4)	(4)	
KLT160A1	1985	<b>12-1019</b> (5)	<b>13-4014</b> (4)	<b>614-421</b> (4)	
KLF185A1-A4 Bayou	85-88	<b>12-1019</b> (5)	<b>13-4014</b> (4)	<b>614-421</b> (4)	
KLT185A1/A2	86-87	<b>12-1019</b> (5)	<b>13-4014</b> (4)	<b>614-421</b> (4)	
KLT200A1-A4A	81-83	<b>12-4049</b> (7)	<b>13-4002</b> (6)	<b>614-406</b> (5)	
KLT200B1	1983	<b>12-4049</b> (7)	<b>13-4002</b> (6)	<b>614-406</b> (5)	
KL200C1/C2	83-84	<b>12-4049</b> (7)	<b>13-4002</b> (6)	<b>614-406</b> (5)	
KLF220A1-A15 Bayou 220	88-02	<b>12-1042/2</b> (5)	<b>13-4031</b> (4)	<b>614-430</b> (4)	<b>643-4042</b>
KLF250A1-A7F Bayou 250	03-07	<b>12-1042/2</b> (5)	<b>13-4031</b> (4)	<b>614-430</b> (4)	<b>643-4042</b>
KLT250A1/A2	82-83	<b>12-4049</b> (7)	<b>13-4002</b> (6)	<b>614-406</b> (5)	
KLT250C1/C2/C3 Prairie	83-85	<b>12-4049</b> (7)	<b>13-4002</b> (6)	<b>614-406</b> (5)	
KLT250P1 Police	1984	<b>12-4049</b> (7)	<b>13-4002</b> (6)	<b>614-406</b> (5)	
KSF250A1-A17 Mojave	87-03	<b>12-4049</b> (7)	<b>13-4002</b> (6)	<b>614-406</b> (5)	<b>643-4040</b>
KSF250A18 KXF250 Mojave	2004	<b>12-4049</b> (7)	<b>13-4002</b> (6)	<b>614-406</b> (5)	<b>643-4040</b>
KXF250A1/A2 Tecate 4	87-88	<b>12-4059</b> (8)	<b>13-4033</b> (7)	<b>614-411</b> (6)	
KXT250A1 Tecate 3	1984	<b>12-1061/4</b> (7)	<b>13-4013</b> (6)	<b>614-412</b> (5)	<b>643-4012</b>
KXT250A2 Tecate 3	1985	<b>12-1061/5</b> (7)	<b>13-4013</b> (6)	<b>614-407</b> (5)	<b>643-4012</b>
KXT250B1/B2 Tecate 3	86-87	(8)	<b>13-4013</b> (7)	<b>614-407</b> (5)	<b>643-4030</b>
KEF300A1-A7 Lakota 300	95-01	<b>12-1061/4</b> (5)	<b>13-4008</b> (4)	<b>614-426</b> (4)	<b>643-4036</b>
KEF300B1/B2/B3 Lakota	01-03	<b>12-1061/4</b> (5)	<b>13-4008</b> (4)	<b>614-426</b> (4)	<b>643-4036</b>
KLF300A1/A2 Bayou	86-87	<b>12-1061/4</b> (5)	<b>13-4008</b> (4)	<b>614-426</b> (4)	<b>643-4036</b>
KLF300B1-B17 Bayou 300	88-04	<b>12-1061/4</b> (5)	<b>13-4008</b> (4)	<b>614-426</b> (4)	<b>643-4036</b>
KLF300C1-C15 300 4x4	89-03	<b>12-1061/4</b> (5)	<b>13-4008</b> (4)	<b>614-426</b> (4)	<b>643-4043</b>
KLF400B1-B7 Bayou 4x4	93-99	<b>12-1061/4</b> (5)	<b>13-4045</b> (5)	<b>614-426</b> (4)	
KSF400A1/A2 KFX400	03-04	(7)	<b>13-3031</b> (7)	(8)	
		(1)			
KSF400A3/A6F KFX400	05-06	(8)	<b>13-3031</b> (8)	(8)	
		(1)			

## Kawasaki Dual Sport & Offroad

Model	Year	Friction Plate each	Drive(Metal) Plate each	Spring Set	Gasket each
KDX50A1/A2/A3	03-06	<b>12-3004</b> (2)	(3)	(3)	
KX60A1/A2	83-84	<b>12-4038</b> (5)	<b>13-4012</b> (4)	<b>614-419</b> (6)	<b>643-4020</b>
KX60B1-B19	85-03	<b>12-4038</b> (5)	<b>13-4012</b> (4)	<b>614-419</b> (6)	<b>643-4020</b>
KX65A1-A7F	00-07	<b>12-4038</b> (5)	<b>13-4048</b> (4)	(6)	
KD80A/A2	75-76	<b>12-4038</b> (4)	<b>13-4012</b> (3)	<b>614-417</b> (6)	
KD80M1-M8	80-87	<b>12-4038</b> (4)	<b>13-4012</b> (3)	<b>614-417</b> (6)	
KD80N1/N2/N3	88-90	<b>12-4038</b> (4)	<b>13-4012</b> (3)	<b>614-419</b> (6)	
KDX80A1/A2	80-81	<b>12-4038</b> (4)	<b>13-4012</b> (3)	<b>614-419</b> (6)	
KDX80B2/B3	82-83	<b>12-4038</b> (5)	<b>13-4012</b> (4)	<b>614-419</b> (6)	<b>643-4020</b>
KDX80C1/C2/C3/C4/C5	84-88	<b>12-4038</b> (5)	<b>13-4012</b> (4)	<b>614-419</b> (6)	<b>643-4020</b>
KX80A1/A2	79-80	<b>12-4038</b> (4)	<b>13-4012</b> (3)	<b>614-419</b> (6)	
KX80C1/C2/	81-82	<b>12-4038</b> (5)	<b>13-4012</b> (4)	<b>614-419</b> (6)	<b>643-4020</b>
KX80E1/E2	83-84	<b>12-4038</b> (5)	<b>13-4012</b> (4)	<b>614-419</b> (6)	<b>643-4020</b>
KX80E3	1985	<b>12-4038</b> (6)	<b>13-4012</b> (5)	<b>614-414</b> (5)	<b>643-4020</b>
KX80G1/G2	86-87	<b>12-4038</b> (6)	<b>13-4012</b> (5)	<b>614-414</b> (5)	<b>643-4032</b>
KX80J2	1987	<b>12-4038</b> (6)	<b>13-4012</b> (5)	<b>614-414</b> (5)	<b>643-4032</b>
KX80L1/L2/L3	88-90	<b>12-4060</b> (7)	<b>13-4012</b> (6)	(5)	<b>643-4032</b>
KX80N1/N2/N3	88-90	<b>12-4060</b> (7)	<b>13-4012</b> (6)	(5)	<b>643-4032</b>
KX80R1-R7	91-97	<b>12-4060</b> (7)	<b>13-4012</b> (5)	(5)	<b>643-4032</b>
KX80T1/T2/T3/T4	91-94	<b>12-4060</b> (7)	<b>13-4012</b> (5)	(5)	<b>643-4032</b>
KX80W1/W2/W3	98-00	<b>12-1019</b> (6)	<b>13-4047</b> (5)	(4)	<b>643-4032(l)</b>
KX85A1-A7F	01-07	<b>12-1019</b> (6)	<b>13-4047</b> (5)	(4)	<b>643-4032(l)</b>
G3TR-90 Bushmaster	69-70	<b>12-4038</b> (4)	<b>13-4012</b> (3)	<b>614-417</b> (6)	
MC1/MC1A/MC1B-90	73-75	<b>12-4038</b> (4)	<b>13-4012</b> (3)	<b>614-417</b> (6)	
MC1M/MC1MA-90	74-75	<b>12-4038</b> (4)	<b>13-4012</b> (3)	<b>614-417</b> (6)	
G31M/G31M A100	70-71	<b>12-4038</b> (4)	<b>13-4012</b> (3)	<b>614-417</b> (6)	
G4TR-100 Trail Boss	1970	<b>12-4038</b> (4)	<b>13-4012</b> (3)	<b>614-417</b> (6)	
G4TRA/B/C/D/E 100	71-75	<b>12-4038</b> (4)	<b>13-4012</b> (3)	<b>614-417</b> (6)	
G5/G5A/B/C-100	72-75	<b>12-4038</b> (4)	<b>13-4012</b> (3)	<b>614-417</b> (6)	
KD100M1/M2/M3/M4	76-79	<b>12-4038</b> (4)	<b>13-4012</b> (3)	<b>614-417</b> (6)	
KE100A5-A10	76-81	<b>12-4038</b> (4)	<b>13-4012</b> (3)	<b>614-417</b> (6)	
KE100B1-B20	82-01	<b>12-4038</b> (4)	<b>13-4012</b> (3)	<b>614-417</b> (6)	
KM100A1-A7	76-8	<b>12-4038</b> (4)	<b>13-4012</b> (3)	<b>614-417</b> (6)	
KV100A7	1976	<b>12-4038</b> (4)	<b>13-4012</b> (3)	<b>614-417</b> (6)	
KX100B5/B6/B7	95-97	<b>12-4060</b> (7)	<b>13-4012</b> (5)	(5)	<b>643-4032</b>
KX100C1/C2/C3	98-00	<b>12-1019</b> (6)	<b>13-4047</b> (5)	(4)	<b>643-4032(l)</b>
KX100D1-D7F	01-07	<b>12-1019</b> (6)	<b>13-4047</b> (5)	(4)	<b>643-4032(l)</b>
F6/A/B-125 Enduro	71-73	<b>12-4041</b> (5)	<b>13-4001</b> (4)	(5)	
KD125/A2/A3/A4/A5	75-79	<b>12-4041</b> (5)	<b>13-4001</b> (4)	<b>614-414</b> (5)	
KS125/A	74-75	<b>12-4041</b> (5)	<b>13-4001</b> (4)	<b>614-414</b> (5)	
KE125A3-A10	76-83	<b>12-4041</b> (5)	<b>13-4001</b> (4)	<b>614-414</b> (5)	
KX125/A/A3	74-76	<b>12-4041</b> (5)	<b>13-4001</b> (4)	(5)	
KX125A4/A5	78-79	<b>12-4041</b> (6)	(4)	<b>614-410</b> (6)	
KX125A6	1980	<b>12-4041</b> (6)	<b>13-4001</b> (5)	<b>614-410</b> (6)	
KX125A7	1981	<b>12-4041</b> (6)	(5)	<b>614-410</b> (6)	
KX125B1	1982	<b>12-4041</b> (6)	(5)	<b>614-410</b> (6)	
KX125B2	1983	<b>12-4041</b> (7)	<b>13-4001</b> (6)	<b>614-410</b> (6)	
KX125C1	1984	<b>12-4041</b> (7)	(6)	<b>614-410</b> (6)	
KX125D1/E1/E2	85-87	<b>12-4058</b> (7)	<b>13-4040</b> (6)	<b>614-410</b> (6)	
KX125F1/G1	88-89	<b>12-4058</b> (8)	<b>13-4040</b> (6)	<b>614-415</b> (5)	<b>643-4046(l)</b>
KX125H1/H2	90-91	<b>12-4058</b> (8)	<b>13-4040</b> (7)	<b>614-415</b> (5)	<b>643-4046(l)</b>
KX125J1	1992	<b>12-4058</b> (8)	<b>13-4040</b> (6)	<b>614-415</b> (5)	
KX125J2	1993	<b>12-4058</b> (6)	<b>13-4044</b> (7)	<b>614-415</b> (5)	
		<b>12-4064</b> (2)			
KX125K1/K2/K3	94-96	<b>12-4063</b> (7)	<b>13-4002</b> (6)	<b>614-430</b> (4)	<b>643-4055(l)</b>
KX125K4/K5	97-98	<b>12-4063</b> (5)	<b>13-4002</b> (6)	<b>614-433</b> (4)	<b>643-4055(l)</b>
		<b>12-4049</b> (2)			
KX125L1/L2/L3/L4	99-02	<b>12-4063</b> (5)	<b>13-4002</b> (6)	<b>614-433</b> (4)	<b>643-4055(l)</b>
		<b>12-4049</b> (2)			<b>643-4055(l)</b>
KX125M1/M2/M3	03-05	<b>12-4063</b> (5)	<b>13-4002</b> (6)	(5)	
		<b>12-4049</b> (2)			
F7A/B/C/D-175 Enduro	71-75	<b>12-4041</b> (5)	<b>13-4001</b> (5)		
KD175A1/A2/A3/A4	76-79	<b>12-4041</b> (5)	<b>13-4001</b> (4)		
KDX175A1/A2/A3	80-82	<b>12-4041</b> (6)	<b>13-4001</b> (5)	<b>614-410</b> (6)	
KE175B1/B2/B3	76-78	<b>12-4041</b> (5)	<b>13-4001</b> (4)	<b>614-413</b> (6)	
KE175D2/D3/D4/D5	80-83	<b>12-4041</b> (5)	<b>13-4001</b> (4)	<b>614-413</b> (6)	
KDX200A1/A2/A3	83-85	<b>12-4041</b> (7)	(6)	<b>614-410</b> (6)	
KDX200C1/C2/C3	86-88	<b>12-4058</b> (7)	<b>13-4026</b> (6)	<b>614-410</b> (6)	<b>643-4037</b>
KDX200E1-E6	89-94	<b>12-4058</b> (8)	<b>13-4026</b> (7)	<b>614-401</b> (5)	<b>643-4037(l)</b>
KDX200H1-H11	95-05	<b>12-1034</b> (8)	<b>13-4031</b> (7)	<b>614-430</b> (4)	<b>643-4037(l)</b>
KDX200H6F	2006	<b>12-1034</b> (8)	<b>13-4031</b> (7)	<b>614-430</b> (4)	<b>643-4037(l)</b>

# Clutch Plates, Clutch Springs, & Clutch Cover Gasket

## Kawasaki Dual Sport & Offroad

Model	Year	Friction Plate each	Drive(Metal) Plate each	Spring Set	Gasket each
KDX220A4-A12	97-05	12-1034 (8)	13-4031 (7)	614-430 (4)	643-4037(I)
KDX250A1/B1	80-81	12-1061/4 (6)	_____ (5)	614-412 (5)	_____
KDX250B2/B3/B4	82-84	12-1061/4 (7)	13-4012 (6)	614-412 (5)	_____
KDX250D1/D2/D3/D4	91-94	12-4059 (8)	13-4045 (7)	_____ (6)	_____
KE250B1/B2/B3	77-79	12-1061/4 (6)	13-4008 (5)	614-415 (5)	_____
KL250A1-A5	78-82	12-4049 (7)	13-4002 (6)	_____ (5)	_____
KL250C1/C2	83-84	12-4049 (7)	13-4002 (6)	614-406 (5)	_____
KL250D2-D22 KLR250	85-05	12-4049 (5)	13-4028 (5)	614-406 (5)	_____
KL250G4-G7 Super Sherpa	00-03	12-4058 (7)	13-4044 (5)	_____ (6)	_____
			13-4038 (1)	_____	_____
KLX250H6F KLX250S	2006	12-4058 (7)	13-4044 (5)	_____ (6)	_____
			13-4038 (1)	_____	_____
KLX250A1/A2	79-80	12-4049 (7)	13-4002 (6)	614-405 (5)	_____
KT250A/A2 Trials	75-76	12-4041(5)	13-4001 (4)	614-410 (6)	_____
KX250A/A3	74-76	_____ (5)	_____ (4)	614-422 (6)	_____
KX250A4/A5	78-79	12-1061/4 (5)	_____ (4)	614-422 (6)	_____
KX250A6/A7	80-81	12-1061/4 (6)	_____ (5)	614-412 (5)	_____
KX250B1	1982	12-1061/4 (7)	13-4013 (6)	614-412 (5)	_____
KX250C1	1983	12-1061/4 (7)	13-4013 (6)	614-412 (5)	_____
KX250C2	1984	_____ (7)	13-4013 (6)	614-412 (5)	_____
KX250D1	1985	_____ (8)	13-4013 (7)	614-412 (5)	643-4030
KX250D2	1986	12-4059 (8)	13-4033 (7)	614-407 (5)	643-4030
KX250E1	1987	12-4059 (8)	13-4033 (7)	614-411 (6)	643-4049(I)
KX250F1	1988	12-4059 (8)	13-4033 (7)	614-411 (6)	643-4049(I)
KX250G1	1989	12-4059 (8)	13-4033 (7)	_____ (6)	643-4049(I)
KX250H1	1990	12-4059 (8)	13-4033 (7)	_____ (6)	643-4049(I)
KX250H2	1991	12-4059 (8)	13-4045 (7)	_____ (6)	643-4049(I)
KX250J1/J2	92-93	12-4040 (8)	13-4022 (7)	614-401 (5)	_____
KX250K1/K2/K3	94-96	12-4040 (8)	13-4022 (7)	614-401 (5)	643-4056(I)
					643-4057(O)
KX250K4/K5	97-98	12-4040 (8)	13-4022 (7)	614-401 (5)	643-4056(I)
					643-4057(O)
KX250L1/L2/L3/L4	99-02	12-4040 (8)	13-4022 (7)	614-401 (5)	643-4056(I)
					643-4057(O)
KX250M1/M2	03-04	12-4040 (8)	13-4022 (7)	614-401 (5)	643-4056(I)
					643-4057(O)
KX250R1/R6F/R7F	05-07	12-4040 (8)	13-4022 (7)	_____ (5)	_____
KLX300A2-A10	97-05	12-4058 (7)	13-4044 (5)	_____ (6)	_____
			13-4038 (1)	_____	_____
KLX300A6F/A7F	06-07	12-4058 (7)	13-4044(5)	_____ (6)	_____
			13-4038 (1)	_____	_____
KDX400A1/A2	79-80	12-1061/4 (6)	_____ (5)	614-411 (6)	_____
KLX400A1 KLX400SR	2003	_____ (7)	13-4059 (7)	_____ (6)	_____
			_____ (1)	_____	_____
KLX400B1 KLX400R	2003	_____ (7)	13-4059 (7)	_____ (6)	_____
			_____ (1)	_____	_____
KDX420B1	1981	12-1061/4 (6)	_____ (5)	614-411 (6)	_____
KX420A1/A2	80-81	12-1061/4 (6)	_____ (5)	614-411 (6)	_____
KDX450A1	1982	12-1061/4 (6)	_____ (5)	614-411 (6)	_____
KX450D6F/D7F	06-07	12-1054 (8)	13-4045 (7)	_____ (5)	_____
KX500A1/A2	83-84	12-1061/4 (7)	13-4013 (6)	614-401 (5)	_____
KX500B1	1985	_____ (8)	13-4013 (7)	614-401 (5)	_____
KX500B2	1986	_____ (8)	13-4013 (7)	614-401 (5)	643-4034
KX500C1	1987	12-4059 (8)	13-4033 (7)	_____ (6)	643-4034
KX500D1	1988	12-4059 (8)	13-4033 (7)	_____ (6)	643-4034
KX500E1-E16	89-04	12-4059 (8)	13-4033 (7)	_____ (6)	643-4034
KL600A1 KLR600	1984	12-4040 (7)	13-4004 (6)	614-407 (5)	643-4013
KL600B1/B2 KLR600	85-86	12-4040 (7)	13-4004 (6)	614-412 (5)	643-4013
KL650A1-A9 KLR650	87-95	12-4040 (7)	13-4024 (6)	614-412 (5)	643-4013
KL650A10-A19 KLR650	96-05	12-4040 (8)	13-4024 (7)	614-401 (5)	643-4013
KL650A6F/A7F KLR650	06-07	12-4040 (8)	13-4024 (7)	614-401 (5)	643-4013
KL650B2/B3 Tengai	90-91	12-4040 (7)	13-4024 (6)	614-412 (5)	643-4013
KLX650A1/A2/A3	93-95	12-4040 (7)	13-4024 (6)	614-412 (5)	_____
KLX650C1-C4 Dual	93-96	12-4040 (7)	13-4024 (6)	614-412 (5)	_____
KLX650D1 KLX650R	1996	12-4040 (7)	13-4024 (6)	614-412 (5)	_____

## Suzuki Street

Model	Year	Friction Plate each	Drive(Metal) Plate each	Spring Set	Gasket each
SP100D Dual Sport	1983	12-3029 (5)	13-3003 (4)	614-318 (5)	_____
GN125Z/D	82-83	12-3029 (5)	13-3003 (4)	614-318 (5)	_____
GN125EM-EV	91-97	12-3029 (5)	13-3003 (4)	614-318 (5)	_____
SP125Z/D Dual Sport	82-83	12-3029 (5)	13-3003 (4)	614-318 (5)	_____
SP125G/H/J Dual Sport	86-88	12-3029 (5)	13-3003 (4)	614-318 (5)	_____
GT185K/L/M/A/B	73-77	12-3029 (6)	13-3003 (5)	614-312 (7)	_____
SP200G/H/J Dual Sport	86-88	12-3029 (6)	13-3003 (5)	614-318 (5)	_____
		12-3029 (2)	_____	_____	_____
GN250Z/D	82-83	12-3039 (4)	_____ (4)	_____ (4)	_____
		12-3041 (1)	_____	_____	_____
GN250F	1985	12-3039 (4)	_____ (4)	_____ (4)	_____
		12-3041 (1)	_____	_____	_____
GN250J	1988	12-3039 (4)	_____ (4)	_____ (4)	_____
		12-3041 (1)	_____	_____	_____
GS250TT/TX	80-81	12-3029 (7)	13-3003 (6)	614-309 (5)	_____
GT250	76-77	_____	_____	614-301 (6)	_____
GZ250X/Y/K1-K5 Marauder	99-05	12-3039 (4)	_____ (4)	_____ (4)	_____
		12-3051 (1)	_____	_____	_____
GS300LZ/LD	82-83	12-3029/2 (8)	_____ (7)	614-318 (5)	_____
GS300LF	1985	12-3029/2 (8)	_____ (7)	614-318 (5)	_____
GN400T/XT/XX/TX/TZ	80-82	12-3039 (6)	13-3004 (5)	614-305 (6)	_____
GS400B/XB/C/XC	77-78	12-3041/2 (6)	13-3004 (5)	614-301 (6)	_____
		_____	_____ (1)	_____	_____
GSF400M/N/P Bandit	91-93	12-3061 (6)	13-3003 (7)	614-318 (5)	_____
		12-3029 (1)	_____	_____	_____
GS425N/EN	1979	12-3041/2 (6)	13-3004 (5)	614-306 (6)	_____
		_____	_____ (1)	_____	_____
GS425LN	1979	12-3041/2 (6)	13-3004 (5)	614-306 (6)	_____
		_____	_____ (1)	_____	_____
GS450ET/EX/EZ/ED	80-83	12-3039 (7)	13-3004 (6)	614-305 (6)	643-3006
GS450LT/LX/LZ/LD	80-83	12-3039 (7)	13-3004 (6)	614-305 (6)	643-3006
GS450LF/LG/LH/LJ	85-88	12-3039 (7)	13-3004 (6)	614-305 (6)	643-3006
GS450ST/SX	80-81	12-3039 (7)	13-3004 (6)	614-305 (6)	643-3006
GS450TX/TZ/TXZ/TXD	81-83	12-3039 (7)	13-3004 (6)	614-305 (6)	643-3006
GS500EK-EK2	89-02	12-3039 (7)	13-3004 (6)	614-323 (6)	643-3006
GS500FK4/FK5/FK6/FK7	04-07	12-3039 (7)	13-3004 (6)	614-323 (6)	643-3006
GS550B/C/EC/N/EN	77-79	12-3041/2 (7)	13-3004 (6)	614-301 (6)	_____
GS550ET	1980	12-3041/2 (7)	13-3004 (6)	614-301 (6)	_____
GS550ED/ESD	1983	12-3041/2 (7)	13-3004 (6)	614-301 (6)	_____
		_____	_____ (1)	_____	_____
GS550ES3-ESG	83-86	12-3041/2 (7)	13-3004 (6)	614-301 (6)	_____
		_____	_____ (1)	_____	_____
GS550LN/LT/LX/LZ	79-82	12-3041/2 (7)	13-3004 (6)	614-301 (6)	_____
GS550LD	1983	12-3041/2 (7)	13-3004 (6)	614-301 (6)	_____
		_____	_____ (1)	_____	_____
GS550LF/LG	85-86	12-3041/2 (7)	13-3004 (6)	614-301 (6)	_____
		_____	_____ (1)	_____	_____
GS550MZ Katana	1982	12-3041/2 (7)	13-3004 (6)	614-301 (6)	_____
GS550TX	1981	12-3041/2 (7)	13-3004 (6)	614-301 (6)	_____
GSF600ST-SK3 Bandit	96-03	12-3039 (8)	_____ (7)	614-328 (4)	643-3039
GSX600FJ-FM Katana	88-91	12-3039 (8)	_____ (7)	614-330 (4)	643-3039
GSX600FP-FV Katana	92-97	12-3063 (8)	13-3001 (9)	614-324 (6)	643-3039
GSX600FW-FK6 Katana	98-06	12-3039 (7)	_____ (7)	614-328 (4)	643-3039
		12-3051 (1)	_____	_____	_____
GSX-R600WN/WP	92-93	12-3063 (8)	13-3002 (7)	614-324 (6)	643-3070
GSX-R600V/VW	97-98	12-1042/2 (8)	13-3005 (7)	_____	_____
		12-1034 (1)	13-3028 (1)	_____	_____
GSX-R600X/Y	99-00	12-1042/2 (8)	_____ (8)	_____	_____
		12-1034 (1)	_____ (1)	_____	_____
GSX-R600K1/K2/K3	01-03	12-1042/2 (8)	13-3039 (7)	_____ (5)	_____
		12-1034 (1)	13-3038 (1)	_____	_____
GSX-R600K4/K5	04-05	12-1042/2 (8)	_____	_____ (5)	_____
		12-1034 (1)	_____	_____	_____
GSX-R600K6/K7	06-07	12-4063 (7)	_____ (6)	_____ (6)	_____
		_____ (1)	13-3047 (1)	_____	_____
RF600RR/RS/RT	94-96	12-3063 (7)	13-3002 (6)	614-324 (6)	643-3070
		_____	13-3001 (1)	_____	_____
GR650D/XD Tempter	1983	12-3039 (7)	_____ (5)	614-313 (4)	_____
		12-3051 (1)	_____	_____	_____

# *Clutch Plates, Clutch Springs, & Clutch Cover Gasket*

VINTAGE INTAKE ENGINE SUSPENSION CONTROL ELECTRICAL CHEMICAL TOOLS WATERCRAFT

## Suzuki Street

Model	Year	Friction Plate each	Drive(Metal) Plate each	Spring Set	Gasket each
GS650EX/EZ	81-82	12-3041 (8)	(8)	614-301 (6)	(6)
GS650GX/GZ/GD	81-83	12-3041 (8)	(8)	614-301 (6)	(6)
GS650GLX/GLZ/GLD	81-83	12-3041 (8)	(8)	614-301 (6)	(6)
GS650MD Katana	1983	12-3041 (8)	(8)	614-301 (6)	(6)
LS650FG/FH Savage	86-87	12-3039 (5)	(5)	614-330 (4)	(4)
		12-3051 (1)	(1)		
LS650PG/PH/PJ Savage	86-88	12-3039 (5)	(5)	614-330 (4)	(4)
		12-3051 (1)	(1)		
LS650PS-PK4 Savage	95-04	12-3039 (5)	(5)	614-330 (4)	(4)
		12-3051 (1)	(1)		
SV650X/Y/K1/K2	99-02	12-3039 (6)	13-3004 (6)	(6)	(6)
		12-3051 (1)	(1)		
SV650K3/K4/K5/K6	03-06	(6)	13-3004 (6)	(6)	(6)
		(1)			
SV650SX/SY/SK1/SK2	99-02	12-3039 (6)	13-3004 (6)	(6)	(6)
		12-3051 (1)	(1)		
SV650SK3/SK4/SK5/SK6	03-06	(6)	13-3004 (6)	(6)	(6)
		(1)			
XN85D Turbo	1983	12-3041 (9)	13-3004 (8)	614-305 (6)	(6)
GS700EF/ESF	1985	12-3041 (8)	(8)	614-313 (4)	643-3016
GV700GLF/GLF2 Madura	1985	12-3039/3 (8)	(8)	614-313 (4)	(4)
VS700GLFG/GLFH Intruder	86-87	12-3039 (6)	(6)	614-313 (4)	(4)
		12-3051 (1)	(1)		
GS750B/C/EC/N/EN	77-79	12-3041/2 (8)	13-3004 (7)	614-303 (6)	643-3001
GS750ET/EX/EZ	80-82	12-3041 (8)	(8)	614-303 (6)	643-3007
GS750ED/ESD	1983	12-3041 (8)	(8)	614-321 (4)	643-3016
GS750LN	1979	12-3041/2 (8)	13-3004 (7)	614-303 (6)	643-3001
GS750LT/LX	80-81	12-3041 (8)	(8)	614-303 (6)	643-3007
GS750SD Katana	1983	12-3041 (8)	(8)	614-303 (6)	643-3007
GS750TZ/TD	82-83	12-3041 (8)	(8)	614-303 (6)	643-3007
GSX750FK-FV Katana	89-97	12-3063 (8)	13-3001 (9)	(4)	643-3039
GSX750FW-FK6 Katana	98-06	12-3039 (7)	(7)	614-328 (4)	643-3039
		12-3051 (1)	(1)		
GSX-R750G/H	86-87	12-3039 (8)	(7)	614-313 (4)	643-3039
GSX-R750J/K	88-89	12-3063 (8)	13-3001 (9)	(4)	643-3039
GSX-R750L/M/N	90-92	12-3063 (8)	13-3001 (9)	614-324 (6)	643-3039
GSX-R750WP/WR/WS	93-95	12-3063 (8)	13-3002 (7)	614-324 (6)	643-3070
GSX-R750T/V/W/X	96-99	12-1042/2 (9)	13-3005 (7)	(7)	(7)
		12-1034 (1)	13-3028 (2)		
GSX-R750Y/K1	00-01	12-1042/2 (10)	(7)	(5)	(5)
		(2)			
GSX-R750K2/K3/K4/K5	02-05	12-1042/2 (9)	(2)		
		12-1034 (1)	(7)		
GSX-R750K6/K7	06-07	12-4063 (8)	(6)	(6)	(6)
		(1)	(1)		
GT750M/A/B Lemans	75-77	12-3041/2 (8)	(7)	614-303 (6)	(6)
VS750GLPJ-GLPM Intruder	88-91	12-3039 (6)	(6)	614-321 (4)	643-3065
		12-3051 (1)	(1)		
VS800GLN-GLK4 Intruder	92-04	12-3039 (6)	(6)	614-321 (4)	643-3065
		12-3051 (1)	(1)		
VS800 Boulevard S50	05-06				643-3065
VX800L/M/N/P	90-93	12-3039 (6)	(6)		643-3065
		12-3051 (1)	(1)		
VZ800V-K3 Marauder	97-04	12-3039 (6)	(6)		
		12-3051 (1)	(1)		
GS850GN/GT/GX	79-81	12-3041 (8)	(8)	614-306 (6)	643-3001
GS850GZ/GD	82-83	12-3041 (8)	(8)	614-306 (6)	643-3009
GS850GLT	1980	12-3041 (8)	(8)	614-306 (6)	643-3001
GS850GLX/GLZ/GLD	81-83	12-3041 (8)	(8)	614-306 (6)	643-3009
RF900RR	1994	12-3052 (10)	13-3009(10)		
		(1)			
RF900RS/RZS/RT/RV	95-97	12-1042/2 (9)	(7)	12-1034 (1)	(2)
DL1000K2-K6 V-Storm	02-06	12-4062 (8)	13-3036 (7)	(5)	(5)
		12-4062/2 (1)	13-3037 (2)		
		(1)			
GS1000C/EC/N/EN/ET	78-80	12-2024/2 (8)	13-3034 (7)	614-303 (6)	643-3002
GS1000GT/GLT/GX/GLX	80-81	12-3045 (9)	13-3010 (8)	614-306 (6)	643-3009
GS1000LN	1979	12-2024/2 (8)	13-3034 (7)	614-303 (6)	643-3009
GS1000SN/ST	79-80	12-2024/2 (8)	13-3034 (7)	614-303 (6)	643-3002
GS1000SZ Katana	1982	12-3045 (9)	13-3010 (8)	614-307 (6)	643-3008
GSX-R1000K1/K2/K3/K4	01-04	12-4063 (10)	13-3040 (9)	(5)	(5)

## Suzuki Street

Model	Year	Friction Plate each	Drive(Metal) Plate each	Spring Set	Gasket each
GSX-R1000K5/K6	05-06	12-4063 (9)	13-3047 (9)	(5)	(5)
		(1)			
SV1000K3/K4/K5	03-05	12-4062 (8)	13-3036 (7)		
		12-4062/2 (1)	13-3037 (2)		
		(1)			
SV1000SK3-SK7	03-07	12-4062 (8)	13-3036 (7)		
		12-4062/2 (1)	13-3037 (2)		
		(1)			
TL1000RW/RX/Ry	98-00	12-3064 (8)	13-3041 (8)	(6)	(6)
		12-3065 (1)			
TL1000RK1/RK2/RK3	01-03	12-3068 (9)	13-3042 (9)	(6)	(6)
		12-3065 (1)			
TL1000SV/SW	97-98	12-1042/2 (9)	13-3008 (7)	(5)	(5)
		12-1034 (1)	13-3028 (2)		
TL1000SX/SY/SK1	99-01	12-3064 (8)	13-3041 (8)	(6)	(6)
		12-3065 (1)			
GS1100ET/EX/EZ	80-82	12-3045 (9)	13-3010 (8)	614-303 (6)	643-3008
GS1100ED/ESD	1983	(10)	13-3010(11)	614-307 (6)	643-3008
GS1100GZ/GD	82-83	12-3045 (9)	13-3010 (8)	614-305 (6)	643-3009
GS1100GLZ/GLD	82-83	12-3045 (9)	13-3010 (8)	614-305 (6)	643-3009
GS1100GKZ/GK2/GKD/GKE	82-84	12-3045 (9)	13-3010 (8)	614-305 (6)	643-3009
GS1100LT	1980	12-3045 (9)	13-3010 (8)	614-303 (6)	643-3008
GS1100SD	1983	(10)	13-3010(11)	614-307 (6)	643-3008
GSX1100FJ-FP Katana	88-93	12-3052 (11)	13-3010(10)		643-3039
GSX1100GM/GN/GP Shaft	91-93	12-3052 (10)	13-3009(10)		643-3039
GSX-R1100G/H/J	86-88	12-3052 (11)	13-3009(10)	614-321 (4)	643-3039
GSX-R1100K/L/M/N	89-92	12-3052 (10)	13-3009(10)		643-3039
GSX-R1100WP-WV	93-98	12-3052 (10)	13-3009(10)		643-3070
		(1)			
GS1150ES3-ESG	83-86	12-3045 (9)	13-3010 (8)	614-307 (6)	643-3008
GSF1200SV-SK6 Bandit	97-06	12-1042/2 (9)	13-3005 (7)		643-3039
		12-1034 (1)	13-3028 (2)		
GSF1200SAV Bandit	1997	12-1042/2 (9)	13-3005 (7)		643-3039
		12-1034 (1)	13-3028 (2)		
GV1200GLF/GLG Madura	85-86	12-3039 (9)	(9)	614-313 (4)	(4)
		12-3051 (1)			
GV1200GLF2 Madura	1985	12-3039 (9)	(9)	614-313 (4)	(4)
		12-3051 (1)			
GSX1300R Hayabusa	99-01	12-4062 (8)	13-3036 (7)	(6)	(6)
		12-4062/2 (2)	13-3037 (2)		
GSX1300R Hayabusa	02-06	12-4062 (8)	13-3036 (7)	(6)	(6)
		12-4062/2 (1)	13-3037 (2)		
		(1)			
GSX1300RZK Hayabusa	04-06	12-4062 (8)	13-3036 (7)	(6)	(6)
		12-4062/2 (1)	13-3037 (2)		
		(1)			
GV1400GCG/GCH	86-87	12-3039/3(10)	(10)	(4)	(4)
Cavalcade		12-3051 (1)			
GV1400GDG-GDJ	86-88	12-3039/3(10)	(10)	(4)	(4)
		12-3051 (1)			
GV1400GTG/GTH	86-87	12-3039/3(10)	(10)	(4)	(4)
Cavalcade		12-3051 (1)			
VS1400GLFH Intruder	1987	12-3039/3 (9)	(9)		643-3066
		12-3051 (1)			
VS1400GLP Intruder	87-88	12-3039/3 (9)	(9)		643-3066
		12-3051 (1)			
VS1400GLPIntruder	90-04	12-3039/3 (9)	(9)		643-3066
		12-3051 (1)			
VS1400 Boulevard S83	05-06	12-3039/3 (9)	(9)		643-3066
		12-3051 (1)			
VL1500W-K4 Intruder LC	98-04	12-3045 (9)	13-3034 (8)	(5)	643-3066
VL1500LC Boulevard C90	05-06	12-3045 (9)		(5)	643-3066
VZ1600K4 Marauder	2004	12-4044 (8)		(10)	(10)
VZ1600 Boulevard M95	2005	12-4044 (8)		(10)	(10)



# Clutch Plates, Clutch Springs, & Clutch Cover Gasket

## Suzuki ATV

Model	Year	Friction Plate each	Drive(Metal) Plate each	Spring Set	Gasket each
ALT125D/E/F/G	83-86	12-3029 (3)	_____ (2)	_____	_____
LT125D/E/F/G/H	83-87	12-3029 (3)	_____ (2)	_____	_____
LT160E Quadrunner	89-92	12-3029/2 (6)	_____ (5)	_____ (4)	643-3033
LT-F160M-K1 Quadrunner	91-01	12-3029/2 (6)	_____ (5)	_____ (4)	643-3033
LT-F160K3/K4 Quadrunner	03-04	12-3029/2 (6)	_____ (5)	_____ (4)	643-3033
ALT185F	1985	12-3029 (3)	_____ (2)	_____	_____
LT185E/F/G/H	84-87	12-3029 (3)	_____ (2)	_____	_____
LT230E	87-93	12-3029/2 (6)	_____ (5)	614-316 (4)	643-3033
LT230GEF/GEG	85-86	12-3029/2 (6)	_____ (5)	614-316 (4)	643-3033
LT230SF/SG/SH/SJ	85-88	12-3029/2 (6)	_____ (6)	614-318 (4)	643-3034
LT250EFF/EFG	85-86	12-3029/2 (7)	_____ (6)	_____ (4)	_____
LT250RF/RG Quadracer	85-86	12-3029 (6)	(5)	614-318 (5)	643-3036
LT250RH-RN Quadracer	87-92	12-3039/3 (6)	(5)	614-319 (6)	643-3060
LT250SK/SL QuadSport	89-90	12-3029 (7)	13-3003 (6)	614-318 (4)	_____
LT-F250J/K/L/M/N/P	88-93 (7)	_____	(6)	_____	643-3040
LT-F250R/S/T/V/W/X/Y/K1	94-01 (7)	_____	(6)	_____	643-3040
LT-F250FX/FY/FK1/FK2	99-02	12-3029/2 (7)	_____ (6)	614-316 (4)	643-3040
LT-F250K2 Ozark 2WD	2002	12-3029/2 (6)	_____ (5)	614-316 (4)	_____
LT-F250K3 Ozark 2WD	2003	12-3029/2 (7)	_____ (5)	614-316 (4)	_____
LT-F250K4 Ozark 2WD	2004	12-3029/2 (5)	_____ (5)	614-316 (4)	_____
_____	_____	12-3029 (1)	_____	_____	_____
LT-F250K5-K7 Ozark 2WD	05-07	12-3029/2 (7)	_____ (6)	614-316 (4)	_____
LT-Z250K4-K7 Quadsport	04-07	12-3029/2 (5)	_____ (5)	614-316 (4)	_____
_____	_____	12-3029 (1)	_____	_____	_____
LT-4WDH/J/K/L/M/N/P	87-93	12-3029/2 (7)	_____ (6)	614-316 (4)	643-3040
LT-4WDR/S/T/V/W	94-98	12-3029/2 (7)	_____ (6)	_____	643-3040
Quadrunner 250	_____	_____	_____	_____	_____
LT300EH/EJ/EK	87-89	12-3029/2 (7)	_____ (6)	_____ (4)	643-3035
LT-F300FX/FY/FK1/FK2	99-02	12-3029/2 (8)	_____ (7)	614-316 (4)	643-3040
King Quad	_____	_____	_____	_____	_____
LT-F4WDXM/N/P/R/S	91-95	12-3029/2 (8)	_____ (7)	614-316 (4)	643-3040
King Quad 300	_____	_____	_____	_____	_____
LT-F4WDXT/V/W	96-98	12-3029/2 (8)	_____ (7)	614-316 (4)	643-3040
King Quad 300	_____	_____	_____	_____	_____
LT-F400K2/K3/K4	02-04	12-1061/4 (6)	13-3031 (5)	_____ (4)	_____
Eiger 2WD	_____	_____	_____	_____	_____
LT-F400FK2-FK7	02-07	12-1061/4 (6)	13-3031 (5)	_____ (4)	_____
Eiger 4WD	_____	_____	_____	_____	_____
LT-Z400K3/K4	03-04	_____ (7)	13-3031 (7)	_____ (6)	_____
Quadsport Z400	_____	_____ (1)	_____	_____	_____
LT-Z400K5/K6/K7	05-07	_____ (8)	13-3031 (8)	_____ (6)	_____
_____	_____	_____ (1)	_____	_____	_____
LT-R450K6/K7	06-07	_____ (8)	13-3048 (6)	_____ (6)	_____
_____	_____	_____	13-3049 (1)	_____	_____
LT500R Quadracer	87-90	12-3039/3 (8)	_____ (7)	614-319 (6)	643-3067
LT-F500FW-FK2	98-02	12-1061/4 (6)	13-3031 (5)	_____ (4)	_____
LT-F500FK3-FK7	03-07	_____ (6)	13-3031 (5)	_____ (4)	_____
Vinson 4WD	_____	_____	_____	_____	_____

## Suzuki Dual Sport & Offroad

JR50C-K7	78-07	12-3004 (2)	_____ (3)	614-314 (3)	_____
OR50N/T	79-80	12-3029 (3)	13-3003 (2)	614-308 (5)	_____
RM50C/N/T	78-80	12-3029 (3)	13-3003 (2)	614-308 (5)	_____
RM60N/T/X/Z/D	79-83	12-3029 (5)	13-3003 (4)	614-308 (5)	_____
RM60K3	2003	12-4038 (5)	13-4012 (4)	614-419 (6)	643-4020
TS75M/A/B Colt	75-77	12-3021 (4)	_____ (4)	_____ (6)	_____
DS80C/N/T/X/Z/D	78-83	12-3029 (4)	13-3003 (3)	614-308 (5)	_____
DS80F-Y	85-00	12-3029 (4)	13-3003 (3)	614-308 (5)	_____
RM80B	1977	12-3029 (4)	13-3003 (3)	614-308 (5)	_____
RM80C/N/T/X	78-81	12-3029 (5)	13-3003 (4)	614-308 (5)	_____
RM80Z	1982	12-3029 (4)	13-3003 (3)	614-309 (5)	_____
RM80D	1983	12-3029 (4)	13-3003 (3)	614-318 (5)	_____
RM80E/F	84-85	12-3029 (5)	13-3003 (4)	614-318 (5)	_____
RM80G/H/J	86-88	12-3053 (5)	_____ (4)	614-320 (4)	_____
RM80K/L/M/N/P/R/S/T	89-96	12-3029 (5)	_____ (4)	614-325 (5)	_____
RM80V/W/X/Y/K1	97-01	12-3029 (5)	_____ (4)	614-325 (5)	_____
RM85K2/K3/K4/K5/K6/K7	02-07	12-3029 (5)	_____ (4)	614-325 (5)	_____
RM85LK2-LK7	02-07	12-3029 (5)	_____ (4)	614-325 (5)	_____
DR100D/E/F/G/H/J/K/L	83-90	12-3029 (5)	13-3003 (4)	614-318 (5)	_____
DS100C/N/T/X	78-81	12-3029 (5)	13-3003 (4)	614-312 (7)	_____
RM100A	1976	12-3029 (6)	13-3003 (5)	614-312 (7)	_____

## Suzuki Dual Sport & Offroad

Model	Year	Friction Plate each	Drive(Metal) Plate each	Spring Set	Gasket each
RM100B/C	77-78	12-3029 (7)	13-3003 (6)	614-312 (7)	_____
RM100N/T/X	79-81	12-3029 (6)	13-3003 (5)	_____ (7)	_____
SP100D	1983	12-3029 (5)	13-3003 (4)	614-318 (5)	_____
TC100K/L/M/A/B Blazer	73-77	12-3021 (6)	_____ (6)	_____ (6)	_____
TM100L/M	74-75	12-3029 (6)	13-3003 (5)	_____ (7)	_____
TS100K/L/M/A/B Honcho	73-77	12-3021 (6)	_____ (6)	_____ (7)	_____
TS100C/N/T/X	78-81	12-3029 (5)	13-3003 (4)	614-312 (7)	_____
DR125Z/D/E	82-84	12-3029 (5)	13-3003 (4)	614-318 (5)	_____
DR125G/H/J	86-88	12-3029 (5)	13-3003 (4)	614-318 (5)	_____
DR125SER/SES/SET	94-96	12-3029 (5)	13-3003 (4)	614-318 (5)	_____
DS125N/T/X	79-81	12-3029 (5)	13-3003 (4)	614-312 (7)	_____
RM125M	1975	12-3029 (6)	13-3003 (5)	614-312 (7)	_____
RM125A/B/C	76-78	12-3029 (7)	13-3003 (6)	614-312 (7)	_____
RM125N/T	79-80	12-3029 (6)	13-3003 (5)	_____ (7)	_____
RM125X/Z	81-82	12-3029 (7)	13-3003 (6)	614-309 (5)	_____
RM125D	1983	12-3029 (7)	13-3003 (6)	614-318 (5)	_____
RM125E	1984	12-3029/2 (8)	_____ (7)	614-318 (5)	_____
RM125F	1985	12-3029 (7)	13-3003 (6)	614-318 (5)	_____
RM125G/H	86-87	12-3029 (6)	13-3003 (5)	_____ (5)	643-3044
RM125J	1988	12-3029/2 (8)	_____ (7)	_____ (5)	_____
RM125K	1989	12-3029/2 (8)	_____ (7)	_____ (5)	_____
RM125L/M	90-91	12-3029/2 (8)	_____ (7)	_____ (5)	643-3055(I)
RM125N	1992	12-3062 (8)	_____ (7)	614-327 (5)	643-3074(I)
RM125P/R/S/T/V	93-97	12-3062 (8)	_____ (7)	_____ (5)	643-3074(I)
RM125W/X/Y/K1/K2	98-02	12-3062 (8)	_____ (7)	_____ (5)	_____
RM125K3/K4/K5/K6/K7	03-07	12-4063 (8)	_____ (7)	_____ (5)	_____
RV125K/L/M/A/B	73-77	12-3029 (5)	13-3003 (4)	_____ (5)	_____
SP125Z/D	82-83	12-3029 (5)	13-3003 (4)	614-318 (5)	_____
SP125G/H/J	86-88	12-3029 (5)	13-3003 (4)	614-318 (5)	_____
TC125J/K/L/M/A/B	72-77	12-3029 (5)	13-3003 (4)	_____ (7)	_____
TM125K/L/M Challenger	73-75	12-3029 (6)	13-3003 (5)	_____ (7)	_____
TS125R/J/K/L/M/A/B Duster	71-77	12-3029 (5)	13-3003 (4)	_____ (7)	_____
TS125C/N	78-79	12-3029 (5)	13-3003 (4)	614-312 (7)	_____
TS125T/X	80-81	12-3029 (4)	13-3003 (4)	614-312 (7)	_____
_____	_____	12-3061 (1)	_____ (1)	_____	_____
PE175C/N/I	78-79	12-3029 (7)	13-3003 (6)	614-312 (7)	_____
PE175T/X/Z/D/E	80-84	12-3029 (7)	13-3003 (6)	614-312 (7)	_____
RS175T/X/Z	80-82	12-3029 (7)	13-3003 (6)	614-312 (7)	_____
DS185C/N/T	78-80	12-3029 (6)	13-3003 (5)	614-312 (7)	_____
TC185L/M/A/B Ranger	74-77	12-3029 (6)	13-3003 (5)	_____	_____
TS185R/J	71-72	12-3029 (6)	13-3003 (5)	_____	_____
TS185K/L/M/A Sierra	73-76	12-3029 (6)	13-3003 (5)	_____	_____
TS185B/C/N/T/X	77-81	12-3029 (6)	13-3003 (5)	614-312 (7)	_____
DR200G/H/J	86-88	12-3029 (7)	13-3003 (5)	614-318 (5)	_____
DR200SET-SEK7 Dual	96-07	12-3029 (6)	_____ (6)	614-318 (5)	_____
SP200G/H/J Dual Sport	86-88	12-3029 (6)	13-3003 (5)	614-318 (5)	_____
DR250Z/D	82-83	12-3039 (4)	_____ (4)	614-313 (4)	_____
_____	_____	12-3051 (1)	_____	_____	_____
DR250F	1985	12-3039 (4)	_____ (4)	614-313 (4)	_____
_____	_____	12-3051 (1)	_____	_____	_____
DR250L/M/N/P	90-93	12-3039/3 (7)	13-3004 (6)	614-319 (6)	_____
DR250SL-SES Dual Sport	90-95	12-3039/3 (7)	13-3004 (6)	614-319 (6)	_____
DR-Z250K1-K6	01-06	12-1042/2 (6)	13-3013 (6)	_____ (5)	_____
_____	_____	12-1034 (1)	_____	_____	_____
DS250T	1980	12-3051 (6)	_____ (6)	614-301 (6)	_____
PE250B/C/N	77-79	12-3051 (5)	_____ (5)	614-303 (6)	_____
PE250T/X	80-81	12-3039 (5)	_____ (4)	614-303 (6)	_____
RL250L/M	74-75	12-3051 (6)	_____ (6)	614-301 (6)	_____
RM250A/B/C/C2	76-78	12-3051 (5)	_____ (5)	614-303 (6)	_____
RM250N/T/X	79-81	12-3039 (5)	_____ (4)	614-303 (6)	_____
RM250Z/D/E/F	82-85	12-3039 (5)	_____ (4)	614-303 (6)	_____
RM250G	1986	12-3039/3 (6)	_____ (5)	614-319 (6)	643-3045
RM250H	1987	12-3039/3 (6)	_____ (5)	614-319 (6)	_____
RM250J	1988	12-3039/3 (8)	13-3004 (7)	614-324 (6)	643-3058
RM250K	1989	12-3039/3 (8)	13-3004 (7)	614-324 (6)	643-3059
RM250L/M	90-91	12-3039 (8)	13-3004 (7)	614-324 (6)	643-3059 (I)
RM250N/P	92-93	12-3039/3 (9)	13-3004 (8)	614-326 (6)	643-3059 (I)
RM250R/S	94-95	12-3039/3 (8)	13-3004 (7)	614-326 (6)	643-3075 (I)
RM250TV	96-97	12-4040 (8)	13-3035 (7)	614-326 (6)	_____
RM250W/X/Y	98-00	12-4040 (8)	13-3035 (7)	614-306 (6)	_____
RM250K1/K2	01-02	12-4040 (8)	13-3035 (7)	614-306 (6)	_____

**VINTAGE INTAKE ENGINE SUSPENSION CONTROL ELECTRICAL CHEMICAL TOOLS WATERCRAFT**



# Clutch Plates, Clutch Springs, & Clutch Cover Gasket

## Suzuki Dual Sport & Offroad

Model	Year	Friction Plate each	Drive(Metal) Plate each	Spring Set	Gasket each
RM250K3/K4/K5	03-05	(8)	<b>13-3035</b> (7)	<b>614-306</b> (6)	(6)
RM250K6/K7	06-07	(8)	<b>13-3035</b> (7)	<b>614-326</b> (6)	(6)
RM-Z250K4/K5/K6	04-06	<b>12-4063</b> (8)	<b>13-4002</b> (7)	(5)	<b>643-3059</b> (6)
RMX250K	1989	<b>12-3039/3</b> (8)	<b>13-3004</b> (7)	<b>614-324</b> (6)	<b>643-3059</b> (6)
RMX250L/M	90-91	<b>12-3039</b> (8)	<b>13-3004</b> (7)	<b>614-324</b> (6)	<b>643-3059</b> (6)
RMX250N/P	92-93	<b>12-3039/3</b> (9)	<b>13-3004</b> (8)	<b>614-326</b> (6)	<b>643-3059</b> (6)
RMX250R/S/T/V/W	94-98	<b>12-3039/3</b> (8)	<b>13-3004</b> (7)	<b>614-326</b> (6)	<b>643-3059</b> (6)
RS250T/X	80-81	<b>12-3039</b> (5)	(4)	<b>614-303</b> (6)	(6)
SP250Z/D Dual Sport	82-83	<b>12-3039</b> (4)	(4)	<b>614-321</b> (4)	(4)
		<b>12-3051</b> (1)	(1)		
SP250F Dual Sport	1985	<b>12-3039</b> (4)	(4)	<b>614-321</b> (4)	(4)
		<b>12-3051</b> (1)	(1)		
TM250J/K/L/M Champion	72-75	<b>12-3051</b> (6)	(6)	<b>614-303</b> (6)	(6)
TS250J/K/L/M/A Savage	72-76	<b>12-3051</b> (6)	(6)	<b>614-301</b> (6)	(6)
TS250B/C/N/T/X	77-81	<b>12-3051</b> (6)	(6)	<b>614-301</b> (6)	(6)
DR350L-R Offroad	90-94	<b>12-3039/3</b> (7)	<b>13-3004</b> (6)	<b>614-319</b> (6)	<b>643-3064</b> (6)
DR350S-X Offroad	95-99	<b>12-3039/3</b> (7)	<b>13-3004</b> (6)	<b>614-319</b> (6)	<b>643-3069</b> (6)
DR350SL-SP Dual Sport	90-93	<b>12-3039/3</b> (7)	<b>13-3004</b> (6)	<b>614-319</b> (6)	<b>643-3064</b> (6)
DR350SER-SEX Dual Sport	94-99	<b>12-3039/3</b> (7)	<b>13-3004</b> (6)	<b>614-319</b> (6)	<b>643-3069</b> (6)
DR370C/N	78-79	<b>12-3039/3</b> (5)	(5)	<b>614-303</b> (6)	(6)
RM370A/B	76-77	<b>12-3039/3</b> (6)	(6)	<b>614-303</b> (6)	(6)
SP370C/N Dual Sport	78-79	<b>12-3039/3</b> (5)	(5)	<b>614-303</b> (6)	(6)
DR400T	1980	<b>12-3039</b> (6)	(6)	<b>614-305</b> (6)	(6)
DR-Z400Y-K6	00-06	(7)	<b>13-3031</b> (7)	(6)	(6)
DR-Z400SY-SK7	00-07	(7)	<b>13-3031</b> (7)	(6)	(6)
Dual Sport		(1)	(1)		
DR-Z400SMK5-SMK7	05-07	(7)	<b>13-3031</b> (7)	(6)	(6)
Supermotard		(1)	(1)		
PE400T/X	80-81	<b>12-3039</b> (6)	(5)	<b>614-306</b> (6)	(6)
RM400C	1978	<b>12-3039/3</b> (6)	(6)	<b>614-303</b> (6)	(6)
RM400N/T	79-80	<b>12-3039</b> (6)	(6)	<b>614-303</b> (6)	(6)
SP400T	1980	<b>12-3039</b> (6)	(5)	<b>614-305</b> (6)	(6)
TM400R/J/K/L/M Cyclone	71-75	<b>12-3039/3</b> (7)	(7)	<b>614-303</b> (6)	(6)
TS400L/M/A/B	74-77	<b>12-3039/3</b> (7)	(7)	<b>614-305</b> (6)	(6)
RM-Z450K5/K6	05-06	(8)	<b>13-3048</b> (6)	(6)	(6)
			<b>13-3049</b> (1)	(1)	
RM465X/Z	81-82	<b>12-3039</b> (7)	<b>13-3004</b> (7)	<b>614-303</b> (6)	(6)
DR500X/Z/D	81-83	<b>12-3039</b> (5)	(5)	(4)	(4)
		<b>12-3051</b> (1)	(1)		
RM500D/E	83-84	<b>12-3039</b> (7)	<b>13-3004</b> (7)	<b>614-303</b> (6)	(6)
SP500X/Z/D Dual Sport	81-83	<b>12-3039</b> (5)	(5)	(4)	(4)
		<b>12-3051</b> (1)	(1)		
SP600F Dual Sport	1985	<b>12-3039</b> (5)	(5)	(4)	(4)
		<b>12-3051</b> (1)	(1)		
DR650SL/SM/SN/SP Dual	90-93	<b>12-3039/3</b> (6)	(6)	(4)	<b>643-3068</b> (6)
		<b>12-3051</b> (1)	(1)		
DR650SER/SES Dual Sport	94-95	<b>12-3039/3</b> (6)	(6)	(4)	<b>643-3068</b> (6)
		<b>12-3051</b> (1)	(1)		
DR650SET-SEK7 Dual	96-07	<b>12-3045</b> (8)	<b>13-3034</b> (7)	<b>614-330</b> (4)	(4)
			<b>13-3010</b> (1)	(1)	

## Yamaha Street

RX50K/L Special	83-84	<b>12-2003</b> (2)	(4)	(4)	<b>643-2024</b> (4)
RX50MK Midnight Special	1983	<b>12-2003</b> (2)	(4)	(4)	<b>643-2024</b> (4)
YSR50T/U/W/A/B/D	87-92	<b>12-2003</b> (2)	(4)	(4)	<b>643-2024</b> (4)
DT80H/J/K	81-83	<b>12-2003</b> (3)	(2)	<b>614-219</b> (4)	<b>643-2024</b> (4)
RD125B/C	75-76	<b>12-2007</b> (5)	(5)	<b>614-234</b> (5)	(5)
XT125J/K/KC Dual Sport	82-83	<b>12-2047</b> (4)	(3)	(4)	<b>643-2012</b> (4)
SR185H/J Exciter	81-82	<b>12-2047</b> (5)	(4)	(4)	<b>643-2012</b> (4)
BW200N	1985	<b>12-2047</b> (4)	(4)	<b>614-206</b> (4)	<b>643-2012</b> (4)
		<b>12-2007/2</b> (1)	(1)		
BW200S	1986	<b>12-2047</b> (4)	(4)	<b>614-227</b> (4)	<b>643-2012</b> (4)
		<b>12-2007/2</b> (1)	(1)		
BW200ES/ET/EU	86-88	<b>12-2047</b> (4)	(4)	<b>614-227</b> (4)	<b>643-2012</b> (4)
		<b>12-2007/2</b> (1)	(1)		
TW200T/TC-W1/W1C	87-07	<b>12-2047</b> (5)	(4)	<b>614-206</b> (4)	<b>643-2012</b> (4)
Trailway					
XT200J/K/KC Dual Sport	82-83	<b>12-2047</b> (5)	(4)	(4)	<b>643-2012</b> (4)
XT225D/DC-M/MC Serrow	92-00	<b>12-2047</b> (5)	(5)	<b>614-206</b> (4)	<b>643-2012</b> (4)
		<b>12-2007/2</b> (1)	(1)		

## Yamaha Street

Model	Year	Friction Plate each	Drive(Metal) Plate each	Spring Set	Gasket each
XT225N/NC-WWC Serrow	01-07	<b>12-2047</b> (6)	(5)	<b>614-206</b> (4)	<b>643-2012</b> (4)
RD250A/B	73-75	<b>12-2042</b> (7)	(7)	(6)	(6)
SR250G/H Exciter	80-81	<b>12-2041/2</b> (6)	(5)	<b>614-207</b> (4)	(4)
SR250J Exciter	1982	<b>12-2042</b> (5)	(4)	<b>614-207</b> (4)	(4)
SRX250T/TC	1987	<b>12-2042</b> (5)	(4)	(4)	(4)
XT250G/H/J/K/KC Dual	80-83	<b>12-2041/2</b> (6)	(5)	<b>614-207</b> (4)	(4)
XT250L/LC Dual Sport	1984	<b>12-2042</b> (5)	(4)	<b>614-207</b> (4)	<b>643-2037</b> (4)
XV250U/UC-A/AC	88-90	<b>12-2042</b> (4)	(4)	<b>614-207</b> (4)	(4)
		<b>12-2041</b> (1)	(1)		
XV250G/GC-K/KC Route 66	95-98	<b>12-2042</b> (4)	(4)	<b>614-207</b> (4)	(4)
		<b>12-2041</b> (1)	(1)		
XV250L/LC Virago 250	1999	<b>12-2042</b> (4)	(4)	<b>614-207</b> (4)	(4)
		<b>12-2041</b> (1)	(1)		
XV250P/PC-W1/W1C Virago	02-07	<b>12-2042</b> (4)	(4)	<b>614-207</b> (4)	(4)
		<b>12-2041</b> (1)	(1)		
RD350A/B	73-75	<b>12-2042</b> (7)	(7)	(6)	(6)
RZ350L/N/NC/NCII	84-85	<b>12-2042</b> (7)	(6)	<b>614-226</b> (6)	<b>643-2011</b> (6)
XT350N/NC-M/MC Dual	85-00	<b>12-2042</b> (7)	(6)	<b>614-209</b> (5)	<b>643-2037</b> (5)
DT360A	1974	(7)	(6)	<b>614-207</b> (4)	(4)
XS360C/D/2D	76-77	<b>12-2041</b> (7)	(6)	<b>614-207</b> (4)	(4)
DT400B/C/D/E	75-78	<b>12-2042</b> (7)	(6)	(6)	(6)
FZR400U/SUC-A/SAC	88-90	<b>12-2043</b> (8)	(7)	<b>614-225</b> (5)	<b>643-2052</b> (5)
RD400C/D/E/F	76-79	<b>12-2042</b> (7)	(6)	<b>614-226</b> (6)	<b>643-2011</b> (6)
XS400D/E/F	77-79	<b>12-2041</b> (7)	(6)	<b>614-207</b> (4)	(4)
XS400E/2F	78-79	<b>12-2041</b> (7)	(6)	<b>614-207</b> (4)	(4)
XS400G/H Special	80-81	<b>12-2041</b> (7)	(6)	<b>614-207</b> (4)	(4)
XS400J/K Maxim	82-83	<b>12-2042/2</b> (5)	(4)	<b>614-214</b> (6)	(6)
XS400R/J/RK Seca	82-83	<b>12-2042/2</b> (5)	(4)	<b>614-214</b> (6)	(6)
XS400SG/SH/SJ Special	80-82	<b>12-2041</b> (7)	(6)	<b>614-207</b> (4)	(4)
SR500E/F/G/H	78-81	<b>12-2041/2</b> (8)	(7)	<b>614-204</b> (6)	<b>643-2003</b> (6)
TX500A	73-74	<b>12-2041</b> (8)	(7)	(6)	(6)
XS500B/C/D/E	75-78	<b>12-2041</b> (8)	(7)	(6)	(6)
XT500C/D/E/E/F/G/H Dual	76-81	<b>12-2041/2</b> (8)	(7)	<b>614-204</b> (6)	<b>643-2003</b> (6)
XV500K Virago	1983	<b>12-2044</b> (6)	(5)	<b>614-247</b> (5)	(5)
XV535T/TC/U/UC Virago	87-88	<b>12-2044</b> (6)	(5)	<b>614-247</b> (5)	(5)
XV535A/AC Virago	1990	<b>12-2044</b> (6)	(5)	<b>614-247</b> (5)	(5)
V535E/EC-M/MC Virago	93-00	<b>12-2044</b> (6)	(5)	<b>614-247</b> (5)	(5)
XV535S Virago	94-97	<b>12-2044</b> (6)	(5)	<b>614-247</b> (5)	(5)
XJ550H/J/K Maxim	81-83	<b>12-2041</b> (7)	(7)	<b>614-209</b> (5)	<b>643-2006</b> (5)
		<b>12-2042</b> (1)	(1)		
XJ550RH/RJ/RK Seca	81-83	<b>12-2041</b> (7)	(7)	<b>614-209</b> (5)	<b>643-2006</b> (5)
		<b>12-2042</b> (1)	(1)		
XZ550R/J/RK Vision	82-83	<b>12-2041/2</b> (8)	(7)	<b>614-209</b> (5)	(5)
FJ600L/LC/N/NC	84-85	<b>12-2041</b> (8)	(7)	<b>614-209</b> (5)	<b>643-2006</b> (5)
FZ600S/SC/T/TC/U/UC	86-88	<b>12-2041</b> (8)	(7)	<b>614-209</b> (5)	<b>643-2006</b> (5)
FZ600SS/SSC/ST/STC	04-05	(6)	(6)	<b>614-254</b> (6)	(6)
FZ6		<b>12-2041</b> (1)	(1)		
FZ600T/TC/N/VC FZ6	05-06	(6)	(6)	<b>614-254</b> (6)	(6)
		<b>12-2041</b> (1)	(1)		
FZR600W/WC/AC	89-90	<b>12-2043</b> (9)	(8)	<b>614-225</b> (5)	<b>643-2052</b> (5)
FZR600RA/RAC-RL/RLC	90-99	<b>12-2043</b> (9)	(8)	<b>614-225</b> (5)	<b>643-2052</b> (5)
SRX600S/SC	1986	<b>12-2041/2</b> (6)	(6)	<b>614-210</b> (5)	<b>643-2013</b> (5)
		<b>12-2042</b> (1)	(1)		
XJ600S Seca II	92-98	<b>12-2041</b> (8)	(7)	<b>614-209</b> (5)	(5)
XT600L/LC-EG/EGC Dual	84-95	<b>12-2041/2</b> (6)	(7)	<b>614-210</b> (5)	<b>643-2013</b> (5)
		<b>12-2042</b> (1)	(1)		
YZF600RG/RGC-RV/RVC	95-06	<b>12-2054</b> (9)	(8)	<b>614-201</b> (6)	(6)
YZF-R6L/LC-T/TC (R6)	99-05	(8)	(7)	(6)	(6)
YZF-R6V/VC (R6)	2006	(9)	(8)	(6)	(6)
YZF-R6SN/SNC	2001	(8)	(7)	(6)	(6)
Champions LTD Edition			(1)	(6)	(6)
YZF-R6SR/SRC	2003	(8)	(7)	(6)	(6)
			(1)		
YZF-R6SV/SVC	2006	(8)	(7)	(6)	(6)
YZF-R6SPV/SPVC	2006	(9)	(8)	(6)	(6)
YX600S/SC-A/AC Radian	86-90	<b>12-2041</b> (8)	(7)	<b>614-209</b> (5)	<b>643-2006</b> (5)
TX650A	1974	<b>12-2042/2</b> (7)	(6)	<b>614-214</b> (6)	<b>643-2002</b> (6)
XS650B/C/D/E/F/2F	75-79	<b>12-2042/2</b> (7)	(6)	<b>614-214</b> (6)	<b>643-2002</b> (6)
XS650G/H Special II	80-81	<b>12-2042/2</b> (6)	(5)	(6)	<b>643-2002</b> (6)
XS650SE/SF Special	78-79	<b>12-2042/2</b> (7)	(6)	<b>614-214</b> (6)	<b>643-2002</b> (6)
XS650SG/SH Special	80-81	<b>12-2042/2</b> (6)	(5)	<b>614-201</b> (6)	<b>643-2002</b> (6)



# Clutch Plates, Clutch Springs, & Clutch Cover Gasket

VINTAGE

INTAKE

ENGINE

SUSPENSION

CONTROL

ELECTRICAL

CHEMICAL

TOOLS

WATERCRAFT

## Yamaha Street

Model	Year	Friction Plate each	Drive(Metal) Plate each	Spring Set	Gasket each
XS650SJ/SK Heritage	82-83	12-2024/2 (6)	(5)	614-201 (6)	643-2002
XJ650G/H/J/K Maxim	80-83	12-2041 (8)	(8)	614-205 (5)	643-2022
XJ650LH Midnight Maxim	1981	12-2041 (8)	(8)	614-205 (5)	643-2022
XJ650LJ/LK Seca Turbo	82-83	12-2041 (8)	(8)	614-216 (5)	643-2022
XJ650RJ Seca	1982	12-2041 (8)	(8)	614-205 (5)	643-2022
XVS650AK/AKC-AV/AVC	98-06	12-2044 (7)	(7)	614-247 (5)	
V-Star Classic					
XVS650AT	03-06	12-2044 (7)	(7)	614-247 (5)	
V-Star Silverado					
XVS650K/KC-S/SC	98-04	12-2044 (7)	(7)	614-247 (5)	
V-Star Custom					
XVS650T/TC/V/VC	05-06	12-2044 (7)	(7)	614-247 (5)	
V-Star Midnight Custom					
FZ700T/TC	1987	12-2041 (7)	(8)	614-254 (6)	643-2045
		12-2042 (1)			
FZX700S/SC/T/TC	86-87	12-2041 (8)	(8)	614-254 (6)	643-2045
XJ700N/NC/S/SC Maxim	85-86	12-2041 (8)	(8)		(6)
XJ700XN/XS Maxim X	85-86	12-2041 (8)	(8)		(6)
XV700L/LC/N/NC Virago	84-85	12-2044 (8)	(7)	614-211 (6)	643-2005
XV700CS/CSC/CT/CTC	86-87	12-2044 (8)	(7)	614-211 (6)	643-2005
XV700SS/SSC Virago	1986	12-2044 (8)	(7)	614-211 (6)	643-2005
FZ750N/S/SC	85-86	12-2041 (8)	(8)	614-254 (6)	643-2045
FZ750U/UC	1988	12-2041 (7)	(8)	614-254 (6)	643-2045
		12-2042 (1)			
FZR750RT/RU	87-88	12-2041 (8)	(8)	614-254 (6)	643-2045
		12-2042 (1)			
XS750D/2D	1977	12-2041 (7)	(6)	614-201 (6)	643-2004
XS750E/F	78-79	12-2041 (7)	(6)	614-201 (6)	643-2004
XS750SE/SF Special	78-79	12-2041 (7)	(6)	614-201 (6)	643-2004
XJ750J/K Maxim	82-83	12-2041 (8)	(8)	614-209 (5)	643-2022
XJ750MK Midnight Maxim	1983	12-2041 (8)	(8)	614-209 (5)	643-2022
XJ750RH/RJ/RK Seca	81-83	12-2041 (8)	(8)	614-209 (5)	643-2022
XV750H/J/K Virago	81-83	12-2044 (8)	(7)	614-211 (6)	643-2005
XV750MK Midnight Virago	1983	12-2044 (8)	(7)	614-211 (6)	643-2005
XV750U/UC-G/GC Virago	88-96	12-2044 (8)	(7)	614-211 (6)	643-2005
XV750H1/HC1/J1/JC1 Virago	96-97	12-2044 (8)	(7)	614-211 (6)	643-2005
YZF750RF/RFC	1994	12-2041 (9)	(8)	614-254 (6)	643-2045
YZF750R	96-98	12-2041 (9)	(8)	614-254 (6)	643-2045
TDM850D/DC/E/EC	92-93	12-2041 (9)	(7)	614-254 (6)	
XS850G/H	80-81	12-2041/2 (7)	(6)	614-201 (6)	643-2004
XS850LG/LH Midnight	80-81	12-2041/2 (7)	(6)	614-201 (6)	643-2004
XS850SG/SH Special	80-81	12-2041/2 (7)	(6)	614-201 (6)	643-2004
XJ900RK Seca	1983	12-2041 (8)	(8)		643-2022 (5)
XV920J/K Virago	82-83	12-2044 (8)	(8)	614-204 (6)	643-2005
XV920MK Midnight Virago	1983	12-2044 (8)	(8)	614-204 (6)	643-2005
XV920RH/RJ	81-82	12-2044 (8)	(8)	614-204 (6)	643-2005
FZR1000T/TCU/UC/WWC	87-89	12-2041 (8)	(8)	614-254 (6)	643-2045
		12-2042 (1)			
FZR1000A/AC-D/DC	90-92	12-2041 (7)	(8)	614-254 (6)	643-2045
		12-2041/3 (1)			
		12-2042 (1)			
FZR1000E/EC-G/GC	93-95	12-2041 (8)	(8)	614-254 (6)	643-2045
		12-2041/3 (1)			
GTS1000AE/AEC/AF/AFC	93-94	12-2041 (8)	(8)	614-254 (6)	643-2045
		12-2041/3 (1)			
XV1000L/LC/N/NC Virago	84-85	12-2044 (8)	(8)	614-204 (6)	643-2005
YZF1000RJR/JC	1997	12-2041 (8)	(8)	614-254 (6)	643-2045
		12-2041/3 (1)			
YZF1000RK/RKC	1998	12-2024/2 (7)	(6)		
YZF-R1L/LC/M/MC/N/NC	99-01	12-2024/2 (7)	(7)		(6)
		(1)			
YZF-R1P/PC/R/RC (R1)	02-03	12-2024/2 (7)	(7)		(6)
		(1)			
YZF-R1S/SC/T/TC/V/VC	04-06	12-2044 (7)	(7)		(6)
		(1)			
YZF-R1LEV/LEVC Limited	2006	12-2044 (8)	(7)		(6)
		(1)			
YZF-R1SPV/SPVC	2006	12-2044 (8)	(7)		
		(1)			
50th Anniversary					
FJ1100L/LC/N/NC	84-85	12-2024/2 (6)	(7)		
		12-2033 (2)			

## Yamaha Street

Model	Year	Friction Plate each	Drive(Metal) Plate each	Spring Set	Gasket each
XJ1100J Maxim	1982	12-2024/2 (8)	(8)	614-201 (6)	643-2004
XS1100E/F/G/H	78-81	12-2024/2 (8)	(8)	614-201 (6)	643-2004
XS1100LG/LH Midnight	80-81	12-2024/2 (8)	(8)	614-201 (6)	643-2004
XS1100SF/SG/SH Special	79-81	12-2024/2 (8)	(8)	614-201 (6)	643-2004
XV1100S/SC-L/LC Virago	86-99	12-2044 (8)	(8)		643-2005
XV1100SH/SHC-SK/SKC	96-98	12-2044 (8)	(8)		643-2005
XVS1100 V-Star	99-02	17-5812-(8)	(8)		
FJ1200S/SC/T/TC	86-87	12-2024/2 (6)	(7)		643-2048
		12-2033 (2)			
FJ1200W/WC-D/DC	89-92	12-2024/2 (6)	(7)		643-2048
		12-2033 (2)			
FJ1200AD/ADC/AE/AEC	92-93	12-2024/2 (6)	(7)		643-2048
		12-2033 (2)			
VMX12N/S V-Max	85-86	12-2020 (7)	(7)		
		12-2021 (1)			
VMX12U/UC-V/VC V-Max	88-06	12-2020 (7)	(7)		
		12-2021 (1)			
XVZ12/13 Venture & Royale	83-93	12-2020 (7)	(7)	614-217 (6)	
		12-2021 (1)			
XVZ13 Royal Star	96-00	17-5814 (1)	(1)		
Tour Classic/Tour Deluxe		17-5813 (7)	(6)		
XVZ13 Royal Star Venture	99-01	17-5813 (7)	(6)		
XV1600 Road Star	99-02	17-5814 (8)	(8)		
		17-5813 (1)			

## Yamaha ATV

YFM50RT/RV Raptor 50	05-06	12-2056 (5)	(4)		(8)
YFM80N/S/T/U Moto-4	85-88	12-2056 (6)	(5)		(8)
YFM80D-N/NC Badger	92-01	12-2056 (6)	(5)		(8)
YFM80WP/WR/WS Raptor	02-04	12-2056 (6)	(5)		(8)
YFM80RT/RV Raptor	05-				(8)
YFM80GT/GV/GW Grizzly	05-07				(8)
YFM100T/U/W/A/B Champ	87-91	12-2056/2 (6)	(5)		(8)
		12-2056 (1)			
YT125G/H/J Tri-Moto	80-82	12-2036 (7)	(6)	614-202 (8)	
YT125J/K/L/N Tri-Moto	82-85			614-203 (8)	
YT175J/K/L/N Tri-Moto	82-85	12-2036 (8)			
YFM200N Moto-4	1985	12-2043 (5)	(4)	614-206 (4)	643-2017
YFM200DXS/DXT Moto-4	86-87	12-2043 (5)	(4)	614-206 (4)	643-2017
YFM200DXU/DXW Moto-4	88-89	12-2043 (5)	(4)	614-227 (4)	643-2017
YFS200U-V Blaster	88-06	12-2043 (6)	(6)	614-225 (5)	643-2030
		12-2058 (1)			
YFS200SEV Blaster	2006	12-2043 (6)	(6)	614-225 (5)	643-2030
		12-2058 (1)			
YTM200K/L/N Tri-Moto	83-85	12-2043 (5)	(4)	614-206 (4)	643-2017
YTM200EK/EL Tri-Moto	83-84	12-2043 (5)	(4)	614-206 (4)	643-2017
YTM200ERN Tri-Moto	1985	12-2043 (5)	(4)	614-206 (4)	643-2017
YFM225S/T/U Moto-4	86-88	12-2043 (5)	(4)	614-227 (4)	643-2017
YFU1W (230cc) Pro Hauler	1989	12-2043 (5)	(4)	614-227 (4)	
YFU1TW (230cc) Pro Hauler	1989	12-2043 (5)	(4)	614-227 (4)	
YTM225DRN/DRS Tri-Moto	85-86	12-2043 (5)	(4)	614-227 (4)	643-2017
YTM225DX Tri-Moto	83-85	12-2043 (5)	(4)	614-227 (4)	643-2017
YFB250D-H Timberwolf	92-96	12-2043 (5)	(4)		643-2017
YFB250FW Timberwolf	94-00	12-2043 (5)	(4)		643-2017
YFB250UH-UK Timberwolf	96-98	12-2043 (5)	(4)		643-2017
YFM250W/A/B Moto-4	89-91	12-2043 (5)	(4)		643-2017
YFM250XS Beartracker	2004	12-2043 (5)	(4)		643-2017
YTZ250N/S Tri-Moto	85-86	12-2052 (7)	(6)	(6)	
YFM350ERT-ERG Moto-4	87-95	12-2042 (6)	(4)		643-2041
		12-2041 (1)	(2)		
YFM350FWT-FWJ Big Bear	87-97	12-2042 (6)	(4)		643-2041
		12-2041 (1)	(2)		
YFM350FWB Big Bear	97-99	12-2042 (7)	(6)		643-2041
YFM350FX Wolverine	95-03	12-2042 (7)	(6)		643-2041
YFM350UH-UL Big Bear	96-99	12-2042 (6)	(6)		643-2041
		12-2041 (1)			
YFM350XT-XS/XSC Warrior	87-04	12-2042 (6)	(6)	(5)	643-2041
		12-2041 (1)			



# Clutch Plates, Clutch Springs, & Clutch Cover Gasket

VINTAGE INTAKE ENGINE SUSPENSION CONTROL ELECTRICAL CHEMICAL TOOLS WATERCRAFT

## Yamaha ATV

Model	Year	Friction Plate each	Drive(Metal) Plate each	Spring Set	Gasket each
YFP350U Terrapro	1988	12-2042 (7)	(6)	(5)	
YFZ350T-V Banshee	87-06	12-2042 (7)	(6)	614-226 (6)	643-2011
YFZ350RB Banshee Limited	2003	12-2042 (7)	(6)	614-226 (6)	643-2011
YFZ350LER/LES Limited	03-04	12-2042 (7)	(6)	614-226 (6)	643-2011
YFZ350S Banshee SE	05-06	12-2042 (7)	(6)	614-226 (6)	643-2011
YFZ350SPV Banshee SP	2006	12-2042 (7)	(6)	614-226 (6)	643-2011
YFM400FW Kodiak 4WD	93-98	12-2042 (6)	(6)	(5)	643-2011
		12-2041 (1)			
YFM400FWB Kodiak 4WD	1999	12-2042 (7)	(6)	614-205 (5)	
YFZ450S/T	04-05	12-2044 (7)	(7)	614-254 (6)	
		(1)			
YFZ450V	2006	12-2044 (7)	(7)	614-254 (6)	
		(1)			
YFZ450W	2007	12-2044 (7)	(7)	(6)	
		(1)			
YFZ450BBV	2006	12-2044 (7)	(7)	614-254 (6)	
		(1)			
YFZ450LES Limited Edition	2004	12-2044 (7)	(7)	614-254 (6)	
		(1)			
YFZ450SET Special Edition	2005	12-2044 (7)	(7)	614-254 (6)	
		(1)			
YFZ450SPV Special Edition	2006	12-2044 (7)	(7)	614-254 (6)	
		(1)			
YFM660RN/RNC/RP Raptor	01-02	12-2041 (6)	(7)	614-209 (5)	
		12-2042 (2)			
YFM660RR/RS/RT Raptor	03-05	12-2041 (6)	(7)	614-209 (5)	
		12-2042 (2)			
YFM660RPB Raptor 660R	2002	12-2041 (6)	(7)	614-209 (5)	
Limited Edition Black		12-2042 (2)			
YFM660RLER/RLES Raptor	03-04	12-2041 (6)	(7)	614-209 (5)	
Limited Edition Blk		12-2042 (2)			
YFM660RSET Raptor SE	2005	12-2041 (6)	(7)	614-216 (5)	
		12-2042 (2)			
YFM700RV/RW Raptor	06-07	12-2044 (7)	(7)	614-254 (6)	
		(1)			
YFM700RSPV Raptor	2006	12-2044 (7)	(7)	614-254 (6)	
		(1)			

## Yamaha Dual Sport & Offroad

DT50U/W/A	88-90	12-2003 (3)	(2)	614-219 (4)	
TT-R50EV/EW	06-07	12-1004 (2)	(4)		
YZ50G	1980	12-2003 (3)	(2)	614-219 (4)	643-2024
YZ60H/J/K	81-83	12-2043 (4)	(3)	614-224 (4)	
BW80S/T/U Big Wheel	86-88	12-2056 (6)	(5)		643-2028
BW80A Big Wheel	1990	12-2056 (6)	(5)		643-2028
DT80H/J/K	81-83	12-2003 (3)	(2)	614-219 (4)	643-2024
GT1-80	1973	12-2003 (3)	(2)	614-219 (4)	643-2024
GT80A/B/C	74-76	12-2003 (3)	(2)	614-219 (4)	643-2024
GT80E/F	78-79	12-2003 (3)	(2)	614-219 (4)	643-2024
GTMX/GTMXA/GTMXB-80	73-75	12-2003 (3)	(2)	614-219 (4)	643-2024
GTMXC/GTMXD-80	76-77	12-2003 (3)	(2)	614-219 (4)	643-2024
GTMXE/GTMXF-80	78-79	12-2003 (3)	(2)	614-219 (4)	643-2024
MX80G/H/J	80-82	12-2003 (3)	(2)	614-219 (4)	643-2024
PW80K Y-Zinger	1983	12-2056 (6)	(5)	614-220 (6)	643-2028
PW80N Y-Zinger	1985	12-2056 (6)	(5)	614-220 (6)	643-2028
PW80B-V Y-Zinger	91-06	12-2056 (6)	(5)	614-220 (6)	643-2028
YZ80A	1974	12-2003 (3)	(2)	614-224 (4)	643-2024
YZ80B	1975	12-2003 (3)	(2)	614-224 (4)	643-2024
YZ80C/D	76-77	12-2003/2 (4)	(3)	614-224 (4)	643-2024
YZ80E/F	78-79	12-2003/2 (5)	(4)	614-224 (4)	643-2024
YZ80G	1980	12-2003/2 (4)	(3)	(4)	643-2024
YZ80H	1981	12-2043 (5)	(4)	614-219 (4)	
YZ80J	1982	12-2043 (5)	(4)	614-219 (4)	643-2018
YZ80J/K/L/N	83-85	12-2043 (5)	(4)	614-224 (4)	643-2018
YZ80S/T/U/W/A/B/D	86-92	12-2043 (6)	(5)	614-224 (4)	643-2018
YZ80E1/F1	93-94	12-2043 (6)	(5)	(4)	643-2059
YZ80G1/H1/J1/K1/L1/M1/N1	95-01	12-2043 (7)	(6)	614-225 (5)	643-2059(I)
YZ85P/R/S	02-04	12-2043 (7)	(6)	614-225 (5)	643-2059(I)
YZ85T/V/W1	05-07	12-2043 (7)	(6)	614-234 (5)	643-2059(I)
TT-R90M/MC/N/P/R/S	00-04	12-2060 (5)	(4)	(4)	

## Yamaha Dual Sport & Offroad

Model	Year	Friction Plate each	Drive(Metal) Plate each	Spring Set	Gasket each
TT-R90ER/ES/ET/EV/EW	03-07	12-2060 (5)	(4)	(4)	
MX100A/B	74-75	(5)	(5)	614-225 (5)	
MX100F/G/H/J/K	79-83	12-2003/2 (5)	(4)	614-219 (4)	
RT100A-M	90-00	12-2003/2 (5)	(4)	614-219 (4)	
YZ100C/D	76-77	12-2047 (5)	(4)	614-225 (5)	
YZ100E/F/G/H	78-81	12-2047 (5)	(4)	614-225 (5)	
YZ100J/K	82-83	12-2047 (5)	(4)	614-225 (5)	
IT125G/H	80-81	12-2047 (5)	(4)	614-235 (5)	
MX125A/B	74-75	(5)	(4)	614-235 (5)	
MX125C	1976	12-2047 (6)	(5)	614-225 (5)	
TT-R125ER/ES	03-04	12-2003/2 (5)	(4)	614-224 (4)	
TT-R125ET/EV/EW	05-07	12-2003/2 (5)	(4)	614-224 (4)	
TT-R125M/MC-S	00-04	12-2003/2 (5)	(4)	614-224 (4)	
TT-R125LN/LPC/LR/LS	01-04	12-2003/2 (5)	(4)	614-224 (4)	
TT-R125LT/LV/LW	05-07	12-2003/2 (5)	(4)	614-224 (4)	
TT-R125LER/LES	03-04	12-2003/2 (5)	(4)	614-224 (4)	
TT-R125LET/LEV/LEW	05-07	12-2003/2 (5)	(4)	614-224 (4)	
TT-R125LW/M	2000	12-2003/2 (5)	(4)	614-224 (4)	
XT125J/K/KC Dual Sport	82-83	12-2047 (4)	(3)	(4)	643-2012
YZ125A/B	74-75	(5)	(5)	614-235 (5)	
YZ125C	1976	12-2047 (5)	(5)	614-235 (5)	
YZ125X	1976	12-2047 (6)	(5)	614-235 (5)	
YZ125D	1977	12-2047 (6)	(5)	614-235(5)	
YZ125E	1978	12-2047 (6)	(5)	614-235 (5)	
YZ125F	1979	12-2047 (5)	(5)	614-235 (5)	
YZ125G	1980	12-2047 (5)	(4)	614-225 (5)	
YZ125H	1981	12-2047 (6)	(5)	614-225 (5)	
YZ125J	1982	12-2051 (6)	(5)	614-225 (5)	
YZ125K/L/N	83-85	12-2054 (6)	(5)	614-225 (5)	
YZ125S/T	86-87	12-2054 (6)	(5)	614-248 (5)	
YZ125U	1988	12-2054 (7)	(6)	614-226 (6)	
YZ125W/A	89-90	12-2054 (7)	(6)	614-226 (6)	
YZ125B/D1	91-92	12-2059 (7)	(6)	614-205 (5)	
YZ125E1	1993	12-2059 (8)	(7)	614-205 (5)	
YZ125F1/G1	94-95	12-2059 (8)	(7)	614-205 (5)	643-2064(I)
YZ125H1	1996	12-2059 (8)	(7)	614-216 (5)	643-2064(I)
YZ125J1/K1/L	97-01	12-2059 (8)	(7)	614-205 (5)	643-2064(I)
YZ125P/R/S1	02-04	12-2059 (8)	(7)	614-216 (5)	643-2064(I)
YZ125T1/V/W1	05-07	12-2059 (8)	(7)	614-205 (5)	
IT175D/E/F	77-79	12-2047 (6)	(5)	614-225 (5)	
IT175DG/H/J/K	80-83	12-2047 (6)	(5)	614-225 (5)	
MX175A/B	74-75	12-2006 (5)	(5)	614-235 (5)	
YZ175C	1976	12-2047 (6)	(5)	614-225 (5)	
BW200N/S	85-86	12-2047 (4)	(4)	614-227 (4)	643-2012
		12-2007/2 (1)			
BW200ES/ET/EU	86-88	12-2047 (4)	(4)	614-227 (4)	643-2012
		12-2007/2 (1)			
IT200L/N/S	84-86	12-2047 (6)	(5)	614-225 (5)	
TW200T/TC-W1/W1C	87-07	12-2047 (5)	(4)	614-206 (4)	643-2012
Trailway					
WR200RD	1992	12-2043 (6)	(6)	614-225 (5)	
		12-2058 (1)			
XT200J/K/KC Dual Sport	82-83	12-2047 (5)	(4)	614-206 (4)	643-2012
TT225S/T	86-87	12-2047 (5)	(5)	614-206 (4)	643-2012
		12-2007/2 (1)			
TT-R225L/LC-S/SC	99-04	12-2047 (5)	(5)	614-206 (4)	643-2012
		12-2007/2 (1)			
XT225D/DC-M/MC Serow	92-00	12-2047 (5)	(5)	614-206 (4)	643-2012
		12-2007/2 (1)			
XT225N/NC-W/WC Serow	01-07	12-2047 (6)	(5)	614-206 (4)	643-2012
TT-R230T/TC-W/WC	05-07	12-2047 (5)	(5)	614-206 (4)	643-2012
		12-2007/2 (1)			
DT2MX-250	1972	12-2042 (6)	(8)	(6)	
IT250D/E	77-78	12-2041 (6)	(5)	614-226 (6)	
IT250F	1979	12-2041 (5)	(4)	614-226 (6)	
IT250G	1980	12-2041 (5)	(4)	614-226 (6)	
IT250H/J	81-82	12-2041 (7)	(6)	614-226 (6)	643-2016
IT250K	1983	12-2052 (7)	(6)	614-226 (6)	643-2016
MX250/A	73-74	12-2042 (6)	(7)	(6)	
MX250B	1975	(7)	(6)	614-228 (6)	
TT250G/H/J	80-82	12-2041/2 (6)	(5)	614-207 (4)	



# Clutch Plates, Clutch Springs, & Clutch Cover Gasket

## Yamaha Dual Sport & Offroad

Model	Year	Friction Plate each	Drive(Metal) Plate each	Spring Set	Gasket each
TT250RL/RLC	1999	12-2059 (7)	(6)	614-216 (5)	(5)
TT-R250M/MC-VVC	00-06	12-2059 (7)	(6)	614-216 (5)	(5)
WR250ZB/ZD/ZE	91-93	12-2044 (7)	(6)	614-228 (6)	643-2046 (I)
WR250ZF/ZG/ZH/ZJ	94-97	12-2044 (8)	(7)	614-228 (6)	643-2046 (I)
WR250FN-FV	01-06	12-2059 (9)	(8)	614-216 (5)	(5)
XT250G/H/J/K/KC Dual	80-83	12-2041/2 (6)	(5)	614-207 (4)	(4)
XT250L/LC Dual Sport	1984	12-2042 (5)	(4)	614-207 (4)	643-2037
YZ250A/B	74-75	12-2041 (6)	(5)	(6)	(6)
YZ250C	1976	(7)	(6)	614-226 (6)	(6)
YZ250D	1977	12-2041 (6)	(5)	614-226 (6)	(6)
YZ250E	1978	12-2041 (6)	(5)	614-226 (6)	(6)
YZ250F	1979	12-2041 (5)	(4)	614-226 (6)	(6)
YZ250G	1980	12-2041 (6)	(5)	614-226 (6)	643-2016
YZ250H	1981	12-2041 (7)	(6)	614-226 (6)	643-2016
YZ250J/K/L	82-84	12-2052 (7)	(6)	614-226 (6)	(6)
YZ250N/S/T	85-87	12-2052 (7)	(6)	614-204 (6)	(6)
YZ250U/W	88-89	12-2044 (7)	(6)	614-211 (6)	643-2046
YZ250A/B/D1	90-92	12-2044 (7)	(6)	614-211 (6)	643-2046 (I)
YZ250E1/F1/G1/H1/J1/K1	93-98	12-2044 (8)	(7)	614-211 (6)	643-2046 (I)
YZ250L1	1999	12-2044 (8)	(7)	614-211 (6)	(6)
YZ250M1/N	00-01	12-2044 (8)	(7)	(6)	(6)
YZ250P-D2	02-12	12-2044 (8)	(7)	(6)	(6)
YZ250WRW/WRA	89-90	12-2044 (7)	(6)	614-211 (6)	643-2046
YZ250FN-FV	01-06	12-2059 (9)	(8)	614-216 (5)	(5)
BW350T/U Big Wheel	87-88	12-2042 (7)	(6)	614-216 (5)	(5)
TT350S/T	86-87	12-2042 (7)	(6)	614-209 (5)	643-2037
TY350N/S Trials	85-86	12-2052 (6)	(5)	(6)	(6)
XT350N/NC-M/MC Dual	85-00	12-2042 (7)	(6)	614-209 (5)	643-2037
RT2MX-3600	1972	12-2042 (7)	(8)	(6)	(6)
YZ360A/B	74-75	12-2041 (6)	(5)	(6)	(6)
IT400C	1976	12-2041 (7)	(6)	614-226 (6)	(6)
IT400D/E	77-78	12-2041 (7)	(6)	614-226 (6)	(6)
IT400F	1979	12-2041 (7)	(6)	614-226 (6)	(6)
WR400FK/FL/FM	98-00	12-2041/2 (7)	(7)	(5)	(5)
		12-2041 (1)	(1)	(1)	(1)

## Yamaha Dual Sport & Offroad

Model	Year	Friction Plate each	Drive(Metal) Plate each	Spring Set	Gasket each
YZ400F	1979	12-2041 (7)	(6)	614-226 (6)	(6)
YZ400FK/FL	98-99	12-2041/2 (7)	(7)	614-216 (5)	(5)
		12-2041 (1)	(1)	(1)	(1)
IT425G	1980	12-2041 (7)	(6)	614-226 (6)	(6)
WR426FN/FP	01-02	12-2044 (8)	(8)	(6)	(6)
		(1)	(1)	(1)	(1)
YZ426FM	2000	12-2044 (9)	(8)	614-201 (6)	(6)
YZ426FN	01-02	12-2044 (8)	(8)	(6)	(6)
		(1)	(1)	(1)	(1)
WR450FR/FS	03-04	12-2044 (9)	(8)	(6)	(6)
WR450FT/FV	05-06	12-2044 (8)	(7)	(6)	(6)
YZ450FR/FS/FT/FV	03-06	12-2044 (9)	(8)	(6)	(6)
IT465H/J	81-82	12-2041 (7)	(6)	614-226 (6)	643-2016
YZ465G/H	80-81	12-2041 (7)	(6)	614-226 (6)	643-2016
IT490K/L	83-84	12-2052 (7)	(6)	614-226 (6)	643-2016
YZ490J/K/L/N	82-85	12-2052 (7)	(6)	614-226 (6)	643-2016
YZ490S/T/U/W/A	86-90	12-2052 (7)	(6)	614-226 (6)	643-2016
TT500C/D/E/F/G/H	76-81	12-2041/2 (8)	(7)	614-204 (6)	643-2003
WR500ZD/ZE	92-93	12-2052 (7)	(6)	614-226 (6)	643-2016
XT500C/D/E/E/F/G/H	76-81	12-2041/2 (8)	(7)	614-204 (6)	643-2003
XT550J Dual Sport	1982	12-2041/2 (7)	(7)	614-210 (5)	643-2013
		12-2042 (1)	(1)	(1)	(1)
XT550K Dual Sport	1983	12-2041/2 (6)	(7)	614-210 (5)	643-2013
		12-2042 (2)	(2)	(2)	(2)
TT600K/L/N/S	83-86	12-2041/2 (6)	(7)	614-213 (5)	643-2013
		12-2042 (1)	(1)	(1)	(1)
XT600L/LC-W/WC Dual	84-89	12-2041/2 (6)	(7)	614-213 (5)	643-2013
		12-2042 (1)	(1)	(1)	(1)
XT600EA/EAC-EG/EGC	90-95	12-2041/2 (6)	(7)	614-210 (5)	643-2013
		12-2042 (1)	(1)	(1)	(1)



# OEM - Sudeo Clutch Plate Interchange

## Honda Friction Plates

O.E.M. Reference	Order No.
22201-001-010	12-1012
22201-028-000	12-1004
22201-030-000	12-1004
22201-030-405	12-1004
22201-033-010	12-1017
22201-033-405	12-1017
22201-040-000	12-1012
22201-046-000	12-1017
22201-086-000	12-1011
22201-087-010	12-1012
22201-088-000	12-1012
22201-092-010	12-1011
22201-096-000	12-1017
22201-107-000	12-1019
22201-121-631	12-1017
22201-121-690	12-1017
22201-165-951	12-1012
22201-166-000	12-1019
22201-235-000	12-1034
22201-240-000	12-1025
22201-268-020	12-1059/2
22201-283-000	12-1061/2
22201-286-010	12-1061/3
22201-300-000	12-1033
22201-302-010	12-1034
22201-323-010	12-1059

## Honda Friction Plates

O.E.M. Reference	Order No.
22201-357-020	12-1061/3
22201-360-000	12-1019/2
22201-360-306	12-1019/2
22201-369-000	12-1061/3
22201-371-000	12-1033
22201-376-000	12-1061/3
22201-415-000	12-1061/3
22201-415-306	12-1061/3
22201-422-000	12-1044
22201-430-000	12-1046
22201-444-000	12-1047
22201-444-306	12-1047
22201-463-000	12-1067
22201-961-003	12-1046
22201-GBF-B40	12-1019
22201-GC4-600	12-1019
22201-GC4-701	12-1019
22201-GF6-000	12-1019
22201-GN8-920	12-1019
22201-GS2-000	12-1019
22201-GW8-681	12-1011
22201-HA2-000	12-1042/2
22201-HA5-670	12-1042/2
22201-HE0-000	12-1093
22201-HP1-670	12-1088
22201-HP2-670	12-1019

## Honda Friction Plates

O.E.M. Reference	Order No.
22201-KA3-700	12-1019
22201-KA3-711	12-1042/2
22201-KA3-712	12-1042/2
22201-KA3-760	12-1087
22201-KA4-711	12-1054
22201-KA4-712	12-1054
22201-KAE-000	12-1042/2
22201-KB4-670	12-1019
22201-KBG-671	12-1019
22201-KBG-900	12-1019
22201-KBG-A00	12-1019
22201-KBW-900	12-1019
22201-KE1-000	12-1042/2
22201-KEB-000	12-1019
22201-KEB-600	12-1019
22201-KF0-000	12-1042/2
22201-KG0-980	12-1042/2
22201-KL3-670	12-1042/2
22201-KM4-000	12-1042/2
22201-KPM-850	12-1019
22201-KRN-670	12-1087
22201-KS6-700	12-1087
22201-KY1-000	12-1068
22201-KY2-000	12-1059
22201-KZ3-730	12-1054
22201-MA6-000	12-1059

## Honda Friction Plates

O.E.M. Reference	Order No.
22201-MA7-000	12-1061/2
22201-MAE-000	12-1042/2
22201-MAH-000	12-1061
22201-MAL-600	12-1042/2
22201-MAS-000	12-1042
22201-MAS-E00	12-1042/2
22201-MAV-000	12-1042
22201-MB0-003	12-1061
22201-MBB-000	12-1061
22201-MBN-670	12-1088
22201-MC7-000	12-1067
22201-MCB-610	12-1042
22201-ME2-000	12-1061/3
22201-ME9-000	12-1061
22201-MEB-670	12-1054
22201-MEL-000	12-1059
22201-MEN-670	12-1054
22201-MG3-000	12-1054
22201-MG8-000	12-1061
22201-MG8-010	12-1061
22201-MG9-000	12-1067
22201-MJ1-761	12-1061
22201-MJ8-000	12-1068
22201-MK2-000	12-1054
22201-MK4-600	12-1088
22201-ML0-781	12-1019

Clutch Plates reference continues on next page, 406.



### Motion Pro Clutch Holding Tool

Made from medium carbon steel with hardened jaws. Features 8mm spanner pins. Jaws open up to 5" wide. Hold clutch hubs, flywheels, gears, sprockets, etc. Recommended for square tooth style clutch hubs. **NOT RECOMMENDED** for v-groove or half round style clutch hubs. Sold each.

Order No. **950-728**



### Motion Pro Rotor and Sprocket Holder

Keeps flywheels, rotors and sprockets from rotating during removal and installation. Holds sprockets and rotors with holes center to center at a minimum distance of 13mm and a maximum distance of 230mm. Features 5 and 9mm pins. Adjustable stop-screw keeps tool open at set distance.

Order No. **950-756**

# O.E.M. - Sudeo Clutch Plate Interchange

## Honda Friction Plates

O.E.M. Reference	Order No.
22201-ML4-610	12-1042
22201-ML8-000	12-1079
22201-ML8-600	12-1079
22201-MM5-000	12-1061
22201-MN4-000	12-1059
22201-MN5-010	12-1045
22201-MN5-020	12-1045
22201-MN8-000	12-1042
22201-MN8-700	12-1042
22201-MR7-000	12-1042/2
22201-MR8-000	12-1019
22201-MS6-620	12-1042/2
22201-MT6-601	12-1059
22201-MT7-000	12-1061
22201-MT8-000	12-1045
22201-MV4-000	12-1042/2
22201-MW3-600	12-1059
22201-MW3-960	12-1059
22201-MY3-000	12-1061
22201-MY6-670	12-1061/4
22202-371-000	12-1070
22202-390-000	12-1070
22202-392-000	12-1070
22202-422-000	12-1072
22202-425-000	12-1073
22202-463-000	12-1074
22202-KV3-840	12-1094
22202-KV3-980	12-1094
22202-MAE-000	12-1034
22202-MG8-000	12-1061
22202-ML4-610	12-1034
22202-ML4-611	12-1034
22202-ML8-000	12-1079
22202-ML8-600	12-1079
22202-MN5-020	12-1073
22202-MT8-000	12-1073
22202-MV8-920	12-1034
22331-086-020	12-1077
22331-GW8-681	12-1077

## Honda Metal Plates

22310-GB0-910	13-1020
22311-096-000	13-1021
22311-200-000	13-1046
22311-968-000	13-1004
22311-HE0-000	13-1007
22311-KN4-680	13-1005
22321-041-000	13-1001
22321-046-010	13-1001
22321-046-020	13-1001
22321-360-000	13-1009
22321-371-010	13-1027
22321-422-000	13-1028
22321-425-000	13-1029
22321-429-000	13-1014
22321-HN0-670	13-1049
22321-KA3-700	13-1008
22321-KA4-700	13-1018
22321-KA4-710	13-1015
22321-KE7-000	13-1030
22321-KE8-000	13-1006
22321-KF0-770	13-1011
22321-KZ3-690	13-1019
22321-MAS-000	13-1031
22321-MAT-000	13-1032
22321-MG8-000	13-1033

## Honda Metal Plates

O.E.M. Reference	Order No.
22321-MG8-000	13-1023
22321-MG9-000	13-1027
22321-MM9-000	13-1013
22321-MN5-000	13-1034
22321-MN8-000	13-1035
22321-MR5-670	13-1036
22321-MR7-000	13-1012
22321-MT3-000	13-1017
22321-MV4-000	13-1048
22321-MV9-630	13-1037
22321-MW0-000	13-1038
22322-390-000	13-1039
22322-425-000	13-1040
22322-463-000	13-1041
22322-MEL-000	13-1050
22322-MG9-000	13-1042
22322-ML8-000	13-1043
22322-MN5-000	13-1044
22322-MZ0-000	13-1045
22331-046-000	13-1002
22341-943-000	13-1003
23311-200-000	13-1046
23311-413-000	13-1047
23321-329-000	13-1025
23321-333-010	13-1026

## Kawasaki Friction Plates

13088-0003	12-4063
13088-0005	12-4063
13088-0006	12-4063
13088-0010	12-1054
13088-0012	12-1054
13088-0013	12-4063
13088-0014	12-4063
13088-0015	12-4063
13088-0018	12-4063
13088-0023	12-4040
13088-006	12-4038
13088-015	12-4049
13088-021	12-4052
13088-025	12-4041
13088-030	12-1045
13088-034	12-4049
13088-039	12-4041
13088-040	12-4040
13088-041	12-1061/4
13088-1002	12-4049
13088-1003	12-1061/4
13088-1004	12-4032
13088-1008	12-4049
13088-1009	12-1061/4
13088-1010	12-4038
13088-1011	12-4038
13088-1012	12-1012
13088-1013	12-4040
13088-1015	12-4041
13088-1016	12-1019
13088-1017	12-1004
13088-1018	12-4044
13088-1051	12-4040
13088-1052	12-4062
13088-1056	12-4041
13088-1057	12-4049
13088-1058	12-4058
13088-1062	12-4040
13088-1066	12-4059
13088-1068	12-1042/2

## Kawasaki Friction Plates

O.E.M. Reference	Order No.
13088-1069	12-4059
13088-1070	12-4060
13088-1072	12-4058
13088-1076	12-4058
13088-1077	12-1068/2
13088-1081	12-4058
13088-1082	12-4060
13088-1083	12-4062
13088-1084	12-4063
13088-1085	12-1034
13088-1087	12-4040
13088-1088	12-4065
13088-1089	12-4040
13088-1090	12-4058
13088-1091	12-1061/4
13088-1098	12-1042/2
13088-1101	12-4064
13088-1102	12-4063
13088-1103	12-4038
13088-1105	12-4040
13088-1107	12-4062
13088-1111	12-4038
13088-1113	12-1004
13088-1114	12-4059
13088-1122	12-4058
13088-1124	12-4063
13088-1125	12-4058
13088-1131	12-1059
13088-1132	12-3065
13088-1133	12-4040
13088-1139	12-4040
13088-1140	12-3065
13088-1143	12-1059
13088-1145	12-4062
13088-S001	12-3029
13088-S005	12-3004

## Kawasaki Metal Plates

13089-0003	13-4059
13089-0016	13-4062
13089-0017	13-4063
13089-003	13-4001
13089-005	13-4012
13089-013	13-4002
13089-022	13-4003
13089-026	13-4004
13089-027	13-4005
13089-1001	13-4008
13089-1003	13-4006
13089-1004	13-4007
13089-1005	13-4008
13089-1008	13-4011
13089-1009	13-4012
13089-1010	13-4013
13089-1012	13-4014
13089-1013	13-4015
13089-1014	13-4016
13089-1015	13-4017
13089-1016	13-4018
13089-1017	13-4020
13089-1056	13-4019
13089-1057	13-4020
13089-1063	13-4040
13089-1066	13-4022
13089-1067	13-4023
13089-1068	13-4024
13089-1070	13-4026

## Kawasaki Metal Plates

O.E.M. Reference	Order No.
13089-1071	13-4027
13089-1073	13-4028
13089-1074	13-4033
13089-1075	13-4051
13089-1076	13-4031
13089-1079	13-4033
13089-1080	13-4052
13089-1081	13-4053
13089-1084	13-4054
13089-1085	13-4038
13089-1087	13-4048
13089-1089	13-4040
13089-1092	13-4042
13089-1094	13-4044
13089-1095	13-4045
13089-1097	13-4049
13089-1098	13-4040
13089-1120	13-4047
13089-1123	13-4056
13089-1124	13-4057
13089-1125	13-4058
13089-S001	13-3003

# O.E.M. - Sudeo Clutch Plate Interchange

## Suzuki Friction Plates

O.E.M. Reference	Order No.
21440-19F00	<b>12-3051</b>
21440-35F00	<b>12-1034</b>
21440-39F00	<b>12-1034</b>
21441-01B00	<b>12-3029/2</b>
21441-02B00	<b>12-3053</b>
21441-02F10	<b>12-3064</b>
21441-02F11	<b>12-3064</b>
21441-03B00	<b>12-3029</b>
21441-03B01	<b>12-3029</b>
21441-04400	<b>12-3004</b>
21441-04501	<b>12-3010</b>
21441-04700	<b>12-3011</b>
21441-04710	<b>12-3011</b>
21441-06B00	<b>12-3052</b>
21441-06B01	<b>12-3052</b>
21441-07200	<b>12-3013</b>
21441-07A00	<b>12-3039/3</b>
21441-07A01	<b>12-3039/3</b>
21441-07A02	<b>12-3039/3</b>
21441-08000	<b>12-3015</b>
21441-08001	<b>12-3015</b>
21441-08002	<b>12-3015</b>
21441-09300	<b>12-3041</b>
21441-09D02	<b>12-3004</b>
21441-10000	<b>12-3029</b>
21441-11900	<b>12-3029/2</b>
21441-12000	<b>12-3021</b>
21441-12010	<b>12-3021</b>
21441-12D00	<b>12-3039/3</b>
21441-12D01	<b>12-3039/3</b>
21441-13A00	<b>12-3029</b>
21441-13A01	<b>12-3029</b>
21441-16500	<b>12-3051</b>
21441-16710	<b>12-3025</b>
21441-16711	<b>12-3025</b>
21441-17C02	<b>12-3063</b>
21441-17E10	<b>12-3063</b>
21441-17E21	<b>12-3063</b>
21441-19001	<b>12-3033</b>
21441-19A00	<b>12-3029</b>
21441-19A001	<b>12-3029</b>
21441-20C00	<b>12-3063</b>
21441-21D11	<b>12-3013</b>
21441-22001	<b>12-3013</b>
21441-22A00	<b>12-3029/2</b>
21441-22A01	<b>12-3029/2</b>
21441-24F00	<b>12-4062</b>
21441-24F10	<b>12-4062</b>
21441-24F20	<b>12-4062</b>
21441-24F30	<b>12-4062</b>
21441-25C01	<b>12-3029</b>
21441-28301	<b>12-3029</b>
21441-28C10	<b>12-3039</b>
21441-28C11	<b>12-3039</b>
21441-29B01	<b>12-3029</b>
21441-31600	<b>12-3041/2</b>
21441-31D00	<b>12-3045</b>
21441-31D20	<b>12-3045</b>
21441-31E00	<b>12-1042/2</b>
21441-31E10	<b>12-1042/2</b>
21441-31E20	<b>12-1042/2</b>
21441-31E30	<b>12-1042/2</b>
21441-31E40	<b>12-1042/2</b>
21441-31E50	<b>12-1042/2</b>
21441-31E60	<b>12-1042/2</b>
21441-31E70	<b>12-1042/2</b>
21441-32C00	<b>12-3061</b>

## Suzuki Friction Plates

O.E.M. Reference	Order No.
21441-32C01	<b>12-3061</b>
21441-32C50	<b>12-3029</b>
21441-33C51	<b>12-3029</b>
21441-34000	<b>12-2024</b>
21441-35000	<b>12-3033</b>
21441-35300	<b>12-3033</b>
21441-36200	<b>12-3061</b>
21441-36E00	<b>12-3062</b>
21441-36E10	<b>12-3062</b>
21441-36F00	<b>12-4063</b>
21441-36F10	<b>12-4063</b>
21441-36F20	<b>12-4063</b>
21441-36F30	<b>12-4063</b>
21441-37001	<b>12-2024</b>
21441-37400	<b>12-3039</b>
21441-37410	<b>12-3039</b>
21441-37430	<b>12-3039</b>
21441-37440	<b>12-3039</b>
21441-37E00	<b>12-4040</b>
21441-37E10	<b>12-4040</b>
21441-37E20	<b>12-4040</b>
21441-40400	<b>12-3039</b>
21441-40402	<b>12-3039</b>
21441-40A00	<b>12-3025</b>
21441-40A00	<b>12-3054</b>
21441-40A01	<b>12-3025</b>
21441-40F00	<b>12-4063</b>
21441-40F10	<b>12-4063</b>
21441-41B01	<b>12-3029/2</b>
21441-41B02	<b>12-3029/2</b>
21441-42A00	<b>12-3029</b>
21441-42G00	<b>12-3021</b>
21441-43D00	<b>12-3062</b>
21441-44B00	<b>12-3045</b>
21441-44B01	<b>12-3045</b>
21441-45001	<b>12-3041/2</b>
21441-45100	<b>12-3041</b>
21441-45100	<b>12-3041/2</b>
21441-46000	<b>12-3029</b>
21441-46010	<b>12-3029</b>
21441-48B00	<b>12-3052</b>
21441-48B10	<b>12-3052</b>
21441-49001	<b>12-2024/2</b>
21441-49002	<b>12-2024/2</b>
21441-49200	<b>12-3045</b>
21442-02F10	<b>12-3065</b>
21442-02F11	<b>12-3065</b>
21442-12D00	<b>12-3051</b>
21442-17C00	<b>12-3063</b>
21442-24000	<b>12-3033/2</b>
21442-24001	<b>12-3033/2</b>
21442-31E00	<b>12-1034</b>
21442-31E00	<b>12-3034</b>
21442-31E21	<b>12-1034</b>
21442-37400	<b>12-3051</b>
21442-37401	<b>12-3051</b>
21442-48B00	<b>12-3052</b>
K1308-80005	<b>12-4063</b>
K1308-80006	<b>12-4063</b>
K1308-80014	<b>12-4063</b>
K1308-80015	<b>12-4063</b>

## Suzuki Metal Plates

O.E.M. Reference	Order No.
21451-02F10	<b>13-3041</b>
21451-02F30	<b>13-3042</b>
21451-04400	<b>13-3012</b>
21451-13E10	<b>13-3013</b>
21451-14D00	<b>13-3004</b>
21451-17C00	<b>13-3001</b>
21451-17E00	<b>13-3002</b>
21451-17E10	<b>13-3002</b>
21451-19A00	<b>13-3003</b>
21451-24F00	<b>13-3036</b>
21451-24F10	<b>13-3037</b>
21451-28C30	<b>13-3004</b>
21451-28C31	<b>13-3004</b>
21451-31E00	<b>13-3005</b>
21451-31E10	<b>13-3028</b>
21451-31E20	<b>13-3043</b>
21451-31E20	<b>13-3038</b>
21451-31E30	<b>13-3039</b>
21451-31E30	<b>13-3044</b>
21451-35G00	<b>13-3048</b>
21451-37F00	<b>13-3035</b>
21451-40F00	<b>13-3040</b>
21451-40F10	<b>13-3045</b>
21451-40F20	<b>13-3046</b>
21451-41G00	<b>13-3047</b>
21451-44D00	<b>13-3031</b>
21451-45000	<b>13-3004</b>
21451-48B00	<b>13-3009</b>
21451-49200	<b>13-3010</b>
21452-35G00	<b>13-3049</b>
K1308-91009	<b>13-4012</b>
KK-130-89013	<b>13-4002</b>

## Yamaha Friction Plates

116-16521-00-00	<b>12-2056</b>
131-16321-00-00	<b>12-2003</b>
132-16321-00-00	<b>12-2006</b>
168-16321-10-00	<b>12-2042</b>
1HX-16331-00-00	<b>12-2058</b>
1J7-16321-01-00	<b>12-2041</b>
1LX-16321-00-00	<b>12-2054</b>
1P6-E6330-00-00	<b>12-1004</b>
1V1-16321-00-00	<b>12-2003/2</b>
21V-16321-00-00	<b>12-2043</b>
22F-16521-00-00	<b>12-2056</b>
22U-16321-00-00	<b>12-2044</b>
24X-16321-00-00	<b>12-2054</b>
25G-16521-00-00	<b>12-2031/2</b>
25G-16521-01-00	<b>12-2031/2</b>
25G-16521-02-00	<b>12-2019</b>
25G-16521-02-00	<b>12-2031/2</b>
25G-16521-09-00	<b>12-2019</b>
25G-16521-09-00	<b>12-2031/2</b>
26H-16307-00-00	<b>12-2020</b>
26H-16307-01-00	<b>12-2020</b>
26H-16321-00-00	<b>12-2021</b>
26H-16321-01-00	<b>12-2021</b>
26H-16331-00-00	<b>12-2020</b>
26H-16331-01-00	<b>12-2020</b>
307-16321-00-00	<b>12-2007</b>
307-16321-01-00	<b>12-2007</b>
307-16321-09-00	<b>12-2007</b>
31A-16321-00-00	<b>12-2041</b>
31A-16321-01-00	<b>12-2041</b>
341-16321-00-00	<b>12-2024</b>
341-16321-03-00	<b>12-2024</b>

## Yamaha Friction Plates

O.E.M. Reference	Order No.
341-16321-09-00	<b>12-2024</b>
341-16321-13-00	<b>12-2024/2</b>
360-16321-00-00	<b>12-2042</b>
36X-16321-00-00	<b>12-2007/2</b>
36Y-16331-00-00	<b>12-2033</b>
383-16321-00-00	<b>12-2041</b>
3E5-16521-00-00	<b>12-2056</b>
3FV-16321-00-00	<b>12-2041</b>
3FV-16321-01-00	<b>12-2041</b>
3GM-16321-00-00	<b>12-2041/3</b>
3HA-16321-00-00	<b>12-2006</b>
3JD-16321-00-00	<b>12-2054</b>
3JD-16331-00-00	<b>12-2054</b>
3V3-16321-00-00	<b>12-2035</b>
3X3-16521-00-00	<b>12-2036</b>
3XJ-16321-00-00	<b>12-2059</b>
3XK-16321-00-00	<b>12-2044</b>
3XP-16321-00-00	<b>12-2043</b>
3XV-16321-30-00	<b>12-2059/2</b>
3XV-16321-40-00	<b>12-2059/2</b>
3YR-16321-00-00	<b>12-2060</b>
409-16321-00-00	<b>12-2038</b>
437-16321-00-00	<b>12-2006</b>
4ES-16321-00-00	<b>12-2043</b>
4EU-16321-00-00	<b>12-2003</b>
4FN-16321-00-00	<b>12-2041</b>
4H7-16321-00-00	<b>12-2041</b>
4H7-16321-01-00	<b>12-2041</b>
4H7-16321-02-00	<b>12-2041</b>
4JH-16321-00-00	<b>12-2054</b>
4L0-16321-01-00	<b>12-2042</b>
4V0-16321-00-00	<b>12-2043</b>
4X7-16321-00-00	<b>12-2044</b>
525-16321-00-00	<b>12-2047</b>
537-16321-00-00	<b>12-2047</b>
559-16321-01-00	<b>12-2007/2</b>
56J-16521-00-00	<b>12-2056/2</b>
583-16321-00-00	<b>12-2041/2</b>
598-16321-01-00	<b>12-2003/2</b>
5BE-16321-00-00	<b>12-2041/2</b>
5BE-16331-00-00	<b>12-2041</b>
5DH-16321-00-00	<b>12-2059</b>
5JW-16321-00-00	<b>12-2024/2</b>
5MP-16321-00-00	<b>12-2047</b>
5TA-16321-00-00	<b>12-2044</b>
5TG-16321-00-00	<b>12-2044</b>
5VY-16321-00-00	<b>12-2044</b>
5VY-16330-00-00	<b>12-2044</b>
5X4-16321-00-00	<b>12-2051</b>
5X5-16321-00-00	<b>12-2052</b>
5X5-16321-01-00	<b>12-2052</b>
5XG-E6321-00-00	<b>12-2043</b>
5Y1-16321-00-00	<b>12-2041/2</b>
5Y1-16331-00-00	<b>12-2042</b>
5Y1-16331-01-00	<b>12-2042</b>
99999-00762-00	<b>12-2024</b>



**RK Standard Chain**

These RKM Standard chains are manufactured in Malaysia under technical license from RK Japan. Quality performance at an economical price. Available in the following sizes and links.

Links	M420STD	428STD	428 H-D
Link	_____	<b>316-000</b>	_____
80	_____	_____	_____
82	<b>315-002</b>	_____	_____
84	_____	_____	_____
86	_____	_____	_____
88	_____	_____	_____
90	_____	_____	_____
92	_____	_____	_____
94	_____	_____	_____
96	_____	<b>316-009</b>	_____
98	_____	_____	_____
100	_____	_____	_____
102	_____	_____	_____
104	_____	_____	_____
106	_____	_____	_____
108	_____	_____	_____
110	<b>315-016</b>	_____	<b>320-016</b>
112	_____	_____	<b>320-017</b>
114	_____	_____	_____
116	_____	_____	_____
118	_____	_____	_____
120	_____	_____	_____
Conn. Links	<b>315-099</b>	<b>316-099</b>	_____
25 Ft. Reel	_____	<b>316-100</b>	_____
50 Ft. Reel	_____	_____	_____
100 Ft. Reel	_____	<b>316-102</b>	_____
200 Ft. Reel	_____	_____	_____

**GB520MXZ3**

Non o-ring, heavy duty long lasting chain with gold plated side plate. Recommended for 250cc/500cc MX.

Description	Order No.
1 Link	<b>329-075</b>
Conn. Link	<b>329-083</b>
25 Ft Reel	<b>329-080</b>
100 Ft Reel	<b>329-082</b>

**428HO**

O-ring, heavy duty chain.

Description	Order No.
428HO x 120L	<b>314-021</b>
25 Ft Reel	<b>314-100</b>
100 Ft Reel	<b>314-102</b>

**428MXZ**

Non o-ring, heavy duty chain. Recommended for 125cc MX and below.

Description	Order No.
428MXZ x 120L	<b>320-221</b>
Conn. Link	<b>320-299</b>
100 Ft Reel	<b>320-298</b>

**530DR**

Non o-ring, heavy duty chain. For drag racing.

Description	Order No.
530DR x 1 Link	<b>329-100</b>
530DR Conn. Links	<b>329-099</b>



**“Works” Triplestar Alloy Sportbike Sprockets**

Here's the most cost effective performance and handling improvement modification you can make to your Japanese sportbike. Sunstar Engineering's lightweight 7075-T6 heat treated aircraft grade aluminum Triplestar Sportbike Sprockets save more than 2 pounds of weight over stock steel sprockets to reduce unsprung suspension and reciprocating drive train weight without sacrificing strength. The result is improved handling, quicker acceleration and braking. Combined with a gear ratio change the performance gain can be even more impressive! Each rear sprocket features a computer machined lightening pattern and is completed with an attractive gold anodized finish. Sunstar Triplestar Sportbike Sprockets are used by Team Vance & Hines/Yamaha Superbike and Team

**Sunstar OEM Quality Steel Replacement Sprockets**

The same precision quality original equipment sprockets demanded by Japan's leading motorcycle and ATV manufacturers are available as replacement sprockets in America from Sunstar Engineering. Choose from a complete line of rear sprockets featuring Original Equipment designs of heat treated 1045 High Carbon Steel Rear Sprockets for durability, both in stock and a wide range of optional rear ratios for increased performance or economy. For all front sprocket applications there's Sunstar's Chromoly Steel Countershaft Sprockets which are also heat treated for indestructible strength and durability.

**Chain custom cut to your specific length requirements. Ask your sales rep.**

**\* Specify conn. link or rivet link**

**Also available: Sunstar Master Catalog Order No. 950-992**





## RK X-Ring (XSO) Chain

RK's X-Ring chains feature an X-Ring shaped seal. The X-Ring has two lubrication pools and seal points versus the single seal point/pool design of a regular o-ring chain. X-Ring technology offers less torsional friction, increased high-stress performance, and a 30% longer wear life compared to standard o-ring chains. X-Ring chains offer tremendous value, plus true quality and performance for all but the most demanding high performance applications.



"RX" Ring Cutaway

Links	O-Ring 520XSOZ1	O-Ring 525XSO <b>NEW</b>	O-Ring 530XSO	O-Ring GR530SO "Gold"	O-Ring 630SO	O-Ring 532GSV
1	324-000					
80	324-001		325-001		326-001	
82	324-002		325-002		326-002	
84	324-003		325-003		326-003	
86	324-004		325-004		326-004	
88	324-005		325-005		326-005	
90	324-006		325-006		326-006	
92	324-007		325-007		326-007	
94	324-008		325-008		326-008	
96	324-009		325-009		326-009	
98	324-010		325-010		326-010	
100	324-011		325-011		326-011	
102	324-012		325-012		326-012	
104	324-013		325-013		326-013	
106	324-014		325-014		326-014	
108	324-015		325-015		326-015	
110	324-016		325-016		326-016	329-036
112	324-017		325-017		326-017	
114	324-018	328-405	325-018		326-018	329-035
116	324-019	328-406	325-019		326-019	
118	324-020	328-407	325-020		326-020	329-035
120	324-021		325-021	329-021	326-021	
130	324-026					
Conn. Links	324-099		325-099		326-099	329-039
Rivet Links	324-098		325-098	329-026	326-098	
25 Ft. Reel	324-100		325-100		326-100	
50 Ft. Reel	324-101		325-101		326-101	329-037
100 Ft. Reel	324-102		325-102			

Note: 630SO and 530XSO come with rivet links

## RK Chain Close Out

Limited supply.

Links	GY520X	GY530X	GY530X0	532GSV
Conn.Link				329-039
114			328-140	
120		328-162		
Rivet Link	328-275		328-147	
50 Ft Reel				329-037
100 Ft Reel	328-274	328-166	328-146	



## RK Color O-Ring Chain

Model	Color
<b>520XSO</b>	
NB520XSO x 120	Blue
NM520XSO x 120	Green
NR520XSO x 120	Red
<b>530 XSOZ1</b>	
NB530XSOZ1 x 120	Blue
NM530XSOZ1 x 120	Green
NR530XSOZ1 x 120	Red
<b>520 GXW</b>	
NB520GXW x 120	Blue
NM520GXW x 120	Green
NY520GXW x 120	Yellow
ND520GXW x 120	Orange
NR520GXW x 120	Red
<b>525 GXW</b>	
NB525GXW x 120	Blue
NR525GXW x 120	Red
NM525GXW x 120	Green
NY525GXW x 120	Yellow
<b>530GXW</b>	
NB530GXW x 120	Blue
NM530GXW x 120	Green
NY530GXW x 120	Yellow
ND530GXW x 120	Orange
NR530GXW x 120	Red



## Motion Pro Chain Breaker & Riveting Tool

Order No. 950-420

See page 506 for Chain Tools.

# Fork Seals & Dust Seal Kits



## K&S Fork Seal Kits & Dust Seal Kits

Fork Seals and Dust Seals sold in kits. (pairs)

### Fork Seal Kits (Fork Seals only)

Dimensions	Order No.
27 x 37 x 7.1mm	516-1004
27 x 39 x 10.5mm	516-1005
30 x 40.5 x 10.5mm	516-1006
30 x 42 x 10.5mm	516-1007
31 x 43 x 10mm	516-1008
31 x 43 x 10.3mm	516-1009
31 x 43 x 12.5mm	516-1010
31.7 x 42 x 7/9mm	516-1062K
32 x 42 x 6.5/9.5mm	516-1063K
32 x 44 x 10.5mm	516-1011
33 x 45 x 10.5/12mm	516-1013
33 x 46 x 10.5mm	516-1014
33 x 46 x 11mm	516-1015
34 x 46 x 10.5mm	516-1016
35 x 46 x 11mm	516-1022
35 x 47 x 10.5mm	516-1021
35 x 48 x 8/9.5mm	516-1017
35 x 48 x 10.5mm	516-1019
35 x 48 x 11mm	516-1020
35 x 48 x 13mm	516-1055
36 x 48 x 8/9.5mm	516-1024
36 x 48 x 10.5mm	516-1025
36 x 48 x 11mm	516-1026
37 x 48 x 10.5mm	516-1027
37 x 48 x 12.5mm	516-1028
37 x 49 x 8mm	516-1029
37 x 50 x 11mm	516-1030
38 x 50 x 8mm	516-1032
38 x 50 x 10.5mm	516-1031
38 x 52 x 11mm	516-1033
39 x 51 x 8/10mm	516-1034
39 x 52 x 11mm	516-1035
40 x 52 x 8/9.5mm	516-1036
40 x 50 x 7/10.5mm	516-1057K
41 x 53 x 8mm	516-1037
41 x 53 x 8/9.5mm	516-1038
41 x 53 x 8/10.5mm	516-1039
41 x 53 x 10.5mm	516-1040
41 x 54 x 11mm	516-1041
41.3 x 54 x 13mm	516-1056
43 x 52.7 x 9.5/10.3mm	516-1058K
43 x 54 x 9mm	516-1043
43 x 54 x 9.5mm	516-1045
43 x 54 x 9.5/10mm	516-1049
43 x 54 x 11mm	516-1044
43 x 55 x 8/9.5mm	516-1042
43 x 55 x 9.5/10mm	516-1046
43 x 55 x 10.5mm	516-1047

### Fork Seal Kits (Fork Seals only)

Dimensions	Order No.
45 x 57 x 11mm	516-1048
45 x 58 x 8.5/11mm	516-1054
46 x 58 x 9.5/11mm	516-1050
46 x 58 x 10.5mm	516-1070
48 x 57.7 x 9.5/10.3mm	516-1059K
46 x 58 x 10.5/11mm	516-1051
47 x 58 x 10mm	516-1053
48 x 58 x 11mm	516-1071
49 x 60 x 10mm	516-1052
50 x 60 x 7/10.5mm	516-1060K

### Dust Seal Kits (Dust Seals only)

Dimensions	Order No.
31.7mm Paioli Forks	516-2062K
32mm Marzocchi Forks	516-2063K
35mm Marzocchi Forks	516-2021K
40mm White Power Forks	516-2057K
41mm KYB Forks	516-2038
41mm Showa Forks	516-2041
43mm KYB Forks	516-2046
43mm Showa Forks	516-2049
43mm White Power Forks	516-2058K
45mm Showa Forks	516-2048
45mm KTM Marzocchi Forks	516-2054K
46mm KYB Forks	516-2050
47mm Showa Forks	516-2053
48mm White Power Forks	516-2059K
48mm KYB Forks	516-2071
49mm Showa Forks	516-2052
50mm White Power Forks	516-2060K
50mm KTM Marzocchi Forks	516-2061K





## Buell

Model	Year	Fork Seal Kit	Dust Seal Kit
Cyclone M2 with Showa 43mm forks		<b>516-1044</b>	_____
Lightning X1 with Showa 41mm forks		<b>516-1041</b>	_____
Thunderbolt S3 & S3T w/Showa 41mm		<b>516-1041</b>	_____

## European Applications

Models with 35mm Forks		<b>516-1021</b>	_____
Boge, Ceriani and Telesco Forks, AJS, Bultaco, Can-Am, CZ, Early Husqvarna, Montesa, Moto-Guzzi, Ossa, Penton, Puch, Rokon, KTM models with Betor Forks			
KTM models with 38mm Marzocchi Forks		<b>516-1031</b>	_____
Husqvarna, KTM models with 40mm Marzocchi Forks		<b>516-1036</b>	_____
Husqvarna models with 45mm Showa Forks		<b>516-1048</b>	_____
Husqvarna, KTM models with 45mm Marzocchi Forks		<b>516-1054</b>	_____
Triumph models with 43mm KYB Forks		<b>516-1047</b>	_____
Triumph models with 45mm Showa Forks		<b>516-1048</b>	_____

## Harley-Davidson®

Dyna Glide w/Showa 39mm forks	91-99	<b>516-1035</b>	_____
Dyna Glide FXDWG w/ Showa 41mm	93-99	<b>516-1041</b>	_____
FL models (4-speed) w/41mm forks	78-84	<b>516-1056</b>	_____
FLT models w/41mm forks	80-83	<b>516-1056</b>	_____
FLT models w/ Showa 41mm	84-99	<b>516-1041</b>	_____
FX-1200	1978	<b>516-1055</b>	_____
FXR models w/Showa 35mm forks	84-87	<b>516-1020</b>	_____
FXR models w/Showa 39mm forks	87-00	<b>516-1035</b>	_____
FXB-80	80-82	<b>516-1055</b>	_____
FXDG	1983	<b>516-1055</b>	_____
FXE	81-83	<b>516-1055</b>	_____
FXE-1200	73-80	<b>516-1055</b>	_____
FXEF	79-80	<b>516-1055</b>	_____
FXEF-80	79-81	<b>516-1055</b>	_____
FXEF	1985	<b>516-1020</b>	_____
FXS	77-79	<b>516-1055</b>	_____
FXS-80	79-82	<b>516-1055</b>	_____
FXSB	1983	<b>516-1055</b>	_____
FXSB	1984	<b>516-1041</b>	_____
FXSB	1985	<b>516-1020</b>	_____
FXST Softail	84-86	<b>516-1041</b>	_____
FXWG Wide Glide	80-84	<b>516-1056</b>	_____
FXWG Wide Glide	85-86	<b>516-1041</b>	_____
Softail models w/41mm forks	87-on	<b>516-1041</b>	_____
Sportster models w/KYB 35mm forks	75-83	<b>516-1055</b>	_____
Sportster models w/Showa 35mm forks	84-87	<b>516-1020</b>	_____
Sportster models w/Showa 39mm forks	87-03	<b>516-1035</b>	_____

## Honda Street

MB5-50	1982	<b>516-1005</b>	_____
XL70K/K1	74-76	<b>516-1005</b>	_____
XL75	77-79	<b>516-1005</b>	_____
XL80S	80-85	<b>516-1005</b>	_____
CL90 Scrambler 90	67-69	<b>516-1004</b>	_____
CT90K1-K6 Trail 90	69-75	<b>516-1004</b>	_____
CT90 Trail 90	76-79	<b>516-1004</b>	_____
ST90K0/K1/K2 Trail Sport 90	73-75	<b>516-1005</b>	_____
CB100K0/K1/K2 Super Sport 100	70-72	<b>516-1004</b>	_____
CL100K0/K1/K2 Scrambler 100	70-72	<b>516-1004</b>	_____
CL100S/S2/S3 Scrambler 100	71-73	<b>516-1004</b>	_____
SL100K0/K1 Moto Sport 100 up to frame 21738	70-71	<b>516-1008</b>	_____

## Honda Street

Model	Year	Fork Seal Kit	Dust Seal Kit
SL100K1/K2/K3 Moto Sport 100 from frame 21739	71-73	<b>516-1010</b>	_____
XL100K/K1	74-75	<b>516-1010</b>	_____
XL100	76-78	<b>516-1010</b>	_____
XL100S up to frame 5103463	79-80	<b>516-1010</b>	_____
XL100S from frame 5103464	1980	<b>516-1008</b>	_____
XL100S	81-85	<b>516-1005</b>	_____
CB125S	73-75	<b>516-1004</b>	_____
CB125S	76-82	<b>516-1005</b>	_____
CB125S	84-85	<b>516-1005</b>	_____
CB125TT	1990	<b>516-1008</b>	_____
CL125S/S1 Scrambler 125	73-74	<b>516-1004</b>	_____
MT125K/K1 Elsinore	74-76	<b>516-1010</b>	_____
NX125	88-90	<b>516-1020</b>	_____
SL125K0/K1/K2 Moto Sport	71-73	<b>516-1010</b>	_____
XL125/K1	74-75	<b>516-1010</b>	_____
XL125	76-78	<b>516-1010</b>	_____
XL125S up to frame 5005875	79-80	<b>516-1010</b>	_____
XL125S from frame 5005876	80-82	<b>516-1009</b>	_____
XL125S	1984	<b>516-1009</b>	_____
CB175K3-K7 Super Sport 175	69-73	<b>516-1008</b>	_____
CL175K7 Scrambler 175	1973	<b>516-1008</b>	_____
SL175K0/K1 Moto Sport	70-72	<b>516-1008</b>	_____
XL175K/K1/K2	73-75	<b>516-1010</b>	_____
XL175	76-78	<b>516-1010</b>	_____
CM185T Twinstar	78-79	<b>516-1008</b>	_____
XL185S up to frame 5006890	79-80	<b>516-1010</b>	_____
XL185S from frame 5006891	80-83	<b>516-1008</b>	_____
CB200K	1974	<b>516-1008</b>	_____
CB200T	75-76	<b>516-1008</b>	_____
CL200 Scrambler	1974	<b>516-1008</b>	_____
CM200T Twinstar	80-82	<b>516-1008</b>	_____
TR200	86-87	<b>516-1008</b>	_____
XL200R	83-84	<b>516-1014</b>	_____
CL72 Scrambler 250 <b>35x47x10.5mm</b>	62-65	<b>516-1021</b>	_____
Use on the following frame numbers: 002002 - 0317995 1000001 - 1008850, 1100001 thru 1109459			
CL72 Scrambler 250 <b>35x46x10.5mm</b>	62-65	_____	_____
Used from frame 1008851			
CB250 Nighthawk	91-97	<b>516-1008</b>	_____
CB250 Nighthawk	99-08	<b>516-1008</b>	_____
CM250C Custom	82-83	<b>516-1008</b>	_____
CMX250C Rebel	85-87	<b>516-1014</b>	_____
CMX250C Rebel	97-09	<b>516-1014</b>	_____
CMX250C2 Rebel	99-00	<b>516-1014</b>	_____
CMX250CD Rebel	1986	<b>516-1014</b>	_____
NX250	88-90	<b>516-1030</b>	_____
VTR250 Interceptor	88-90	<b>516-1020</b>	_____
XL250K/K1/K2 Moto Sport	72-75	<b>516-1020</b>	_____
XL250	1976	<b>516-1020</b>	_____
XL250S	80-81	<b>516-1020</b>	_____
XL250R	82-83	<b>516-1020</b>	_____
XL250R	84-86	<b>516-1019</b>	_____
XL250R	1987	<b>516-1020</b>	_____
CB350F/F1 Super Sport (4 cyl)	72-74	<b>516-1014</b>	_____
CB350G Super Sport	1973	<b>516-1014</b>	_____
CB350K4 Super Sport	72-73	<b>516-1014</b>	_____
CL350K4/K5 Scrambler	72-73	<b>516-1014</b>	_____
CB360	1974	<b>516-1014</b>	_____
CB360G	1974	<b>516-1014</b>	_____
CB360T	75-76	<b>516-1014</b>	_____
CJ360T	76-77	<b>516-1014</b>	_____
CL360K/K1 Scrambler	74-75	<b>516-1014</b>	_____
CB400A Automatic	1978	<b>516-1015</b>	_____
CB400F Super Sport	75-77	<b>516-1015</b>	_____
CB400F CB1	89-90	<b>516-1041</b>	<b>516-2041</b>
CB400TI/TII Hawk	78-79	<b>516-1014</b>	_____
CB400T Hawk	80-81	<b>516-1015</b>	_____
CM400A Automatic	79-81	<b>516-1015</b>	_____
CM400C Custom	1981	<b>516-1015</b>	_____
CM400E	80-81	<b>516-1015</b>	_____
CM400T	79-81	<b>516-1015</b>	_____

# Fork Seals & Dust Seal Kits

## Honda Street

Model	Year	Fork Seal Kit	Dust Seal Kit
CB450K1/K2 Super Sport	68-69	516-1022	-----
CB450K3 to frame 4017271	1970	516-1022	-----
CB450K3/K4 frame 4017272 up	70-71	516-1020	-----
CB450K5/K6/K7 Super Sport	72-74	516-1020	-----
CB450SC Nighthawk	82-86	516-1015	-----
CB450T Hawk	1982	516-1015	-----
CM450A Automatic	82-83	516-1015	-----
CM450C Custom	1982	516-1015	-----
CM450E	82-83	516-1015	-----
CMX450C Rebel	86-87	516-1030	-----
CL450K1-K4 Scrambler 450	68-71	516-1022	-----
CL450K5/K6/K7	72-74	516-1020	-----
CB500/K1/K2	71-73	516-1020	-----
CB500T	75-76	516-1020	-----
CX500	78-79	516-1014	-----
CX500C Custom	1979	516-1014	-----
CX500C Custom	1980	516-1015	-----
CX500C Custom	81-82	516-1020	-----
CX500D Deluxe	1979	516-1014	-----
CX500D Deluxe	80-81	516-1015	-----
CX500TC Turbo	1982	516-1030	-----
FT500 Ascot	82-83	516-1030	-----
GB500	89-90	516-1020	-----
GL500 Silverwing	81-82	516-1020	-----
GL500I Silverwing Interstate	81-82	516-1020	-----
VF500C Magna	84-85	516-1030	-----
VF500F Interceptor	84-86	516-1030	-----
VT500C Shadow	83-84	516-1030	-----
VT500FT Ascot	83-84	516-1030	-----
XL500R	1982	516-1030	-----
XL500S	79-81	516-1020	-----
CB550F Super Sport	75-77	516-1020	-----
CB550K	74-78	516-1020	-----
CB550SC Nighthawk	1983	516-1030	-----
CB600F 599	2004	516-1041	516-2041
CB600F 599	2006	516-1041	-----
CBR600F Hurricane	87-90	516-1030	-----
CBR600F2 Hurricane	91-94	516-1041	516-2041
CBR600F3 Hurricane	95-98	516-1041	516-2041
CBR600F4 Hurricane	99-00	516-1044	-----
CBR600F4i Hurricane	01-06	516-1044	-----
CBR600RR	03-06	516-1048	-----
CBR600SE	1998	516-1041	516-2041
CBR600SJR Replica	1996	516-1041	516-2041
FSC600 Silverwing	2002	516-1039	-----
FSC600A Silverwing	03-06	-----	-----
FSC600D Silverwing	03-06	-----	-----
VT600C Shadow VLX	88-97	516-1034	-----
VT600C Shadow	99-06	516-1034	-----
VT600CD Shadow VLX	93-98	516-1034	-----
VT600CD Shadow Deluxe	99-06	516-1034	-----
VT600CD2 Shadow Deluxe	99-00	516-1034	-----
XL600R	83-87	516-1035	-----
XL600V Transalp	89-90	516-1041	-----
CB650	79-82	516-1020	-----
CB650C Custom	80-81	516-1020	-----
CB650SC Nighthawk	1982	516-1030	-----
CB650SC Nighthawk	83-85	516-1035	-----
CX650C Custom	1983	516-1035	-----
CX650T Turbo	1983	516-1030	-----
GL650 Silverwing	1983	516-1030	-----
GL650I Silverwing Interstate	1983	516-1030	-----
NT650 Hawk GT	88-91	516-1041	516-2041
NX650	88-89	516-1041	516-2041
XR650L Dual Sport	93-07	516-1044	-----
CB700SC Nighthawk	84-86	516-1034	-----
VF700C Magna	1984	516-1030	-----
VF700C Magna	85-87	516-1035	-----
VF700F Interceptor	84-85	516-1035	-----
VFR700F/F2 Interceptor	86-87	516-1030	-----
VF700S Sabre	84-85	516-1030	-----
VT700C Shadow	84-87	516-1035	-----

## Honda Street

Model	Year	Fork Seal Kit	Dust Seal Kit
CB750 Nighthawk 750	91-93	516-1041	516-2041
CB750 Nighthawk 750	95-03	516-1041	516-2041
CB750A Automatic	76-78	516-1020	-----
CB750C Custom	80-82	516-1020	-----
CB750F Super Sport	75-80	516-1020	-----
CB750F Super Sport	81-82	516-1030	-----
CB750K1/K2 up to frame 2093730	71-72	516-1022	-----
CB750K2/K3/K4/K5 frame 2093731 UP	72-75	516-1020	-----
CB750K SOHC	76-78	516-1020	-----
CB750K DOHC	79-82	516-1020	-----
CB750L LTD	1979	516-1020	-----
CB750SC Nighthawk	82-83	516-1030	-----
RVF750R RC45	1994	516-1041	516-2041
VF750C Magna	82-83	516-1030	-----
VF750C Magna	1988	516-1035	-----
VF750C Magna	94-03	516-1041	516-2041
VF750CD Magna Deluxe	95-96	516-1041	516-2041
VF750C2 Magna Deluxe	97-00	516-1041	516-2041
VF750F Interceptor	83-84	516-1035	-----
VF750S Sabre	82-83	516-1030	-----
VFR750F Interceptor	1986	516-1030	-----
VFR750F	90-97	516-1041	516-2041
VFR750R RC30	1990	516-1044	-----
VT750C Shadow	1983	516-1035	-----
VT750C Shadow	98-00	516-1038	-----
VT750C Shadow	04-06	-----	-----
VT750CA Shadow	04-06	-----	-----
VT750CD Shadow Deluxe	98-01	516-1038	-----
VT750CD2 Shadow Deluxe	98-01	516-1038	-----
VT750CDA/CDB/CDC/CDD	02-03	516-1038	-----
Shadow ACE 750 Deluxe			
VT750DC Shadow Spirit 750	2001	516-1041	516-2041
VT750DCA Shadow Spirit 750	03-05	516-1041	516-2041
VT750DCA Shadow Spirit 750	2006	-----	-----
VT750DCB Shadow Spirit 750	03-05	516-1041	516-2041
VT750DCB Shadow Spirit 750	2006	-----	-----
PC800 Pacific Coast	89-90	516-1041	516-2041
PC800 Pacific Coast	94-98	516-1041	516-2041
VFR800 Interceptor	02-06	516-1044	-----
VFR800A Interceptor ABS	02-06	516-1044	-----
VFR800Fi Interceptor	98-01	516-1041	516-2041
VT800C Shadow	1988	516-1035	-----
CB900C Custom	80-82	516-1030	-----
CB900F Super Sport	81-82	516-1035	-----
CB900F 919	02-04	516-1044	-----
CB900F 919	2005	-----	-----
CBR900RR	93-99	516-1048	-----
CBR929RR	00-01	516-1044	-----
CBR954RR	02-03	516-1044	-----
CB1000	94-95	516-1044	-----
CB1000C Custom	1983	516-1035	-----
CBR1000F Hurricane	87-88	516-1041	516-2041
CBR1000F Hurricane	90-91	516-1041	516-2041
CBR1000F Hurricane	93-96	516-1041	516-2041
CBR1000RR	04-06	516-1044	-----
CBX	79-80	516-1020	-----
CBX	81-82	516-1035	-----
GL1000** (option) Goldwing	75-77	516-1027	-----
GL1000 Goldwing	75-77	516-1028	-----
GL1000 Goldwing	78-79	516-1028	-----
GL1000L** (option) Goldwing	1976	516-1027	-----
GL1000L Goldwing LTD	1976	516-1028	-----
RVT1000R RC51	00-06	516-1044	-----
VF1000F Interceptor	1984	516-1041	516-2041
VF1000R	85-86	516-1041	516-2041
VTR1000F Super Hawk	98-05	516-1041	516-2041
CB1100F Super Sport	1983	516-1035	-----
CBR1100XX Blackbird	97-03	516-1044	-----
GL1100 Goldwing	80-83	516-1035	-----
GL1100A Goldwing Aspencade	82-83	516-1035	-----
GL1100I Goldwing Interstate	80-83	516-1035	-----
ST1100	91-02	516-1041	516-2041
ST1100A (ABS)	92-95	516-1041	516-2041



## Honda Street

Model	Year	Fork Seal Kit	Dust Seal Kit
ST1100A (ABS)	96-02	<b>516-1044</b>	_____
VF1100C V65 Magna	83-86	<b>516-1041</b>	<b>516-2041</b>
VF1100S V65 Sabre	84-85	<b>516-1041</b>	<b>516-2041</b>
VT1100C Shadow 1100	85-90	<b>516-1041</b>	<b>516-2041</b>
VT1100C Shadow Spirit	98-06	<b>516-1041</b>	<b>516-2041</b>
VT1100C2 Shadow 1100 ACE	95-99	<b>516-1041</b>	<b>516-2041</b>
VT1100C2 Shadow Sabre	00-06	<b>516-1039</b>	_____
VT1100C3 Shadow Aero	98-02	<b>516-1041</b>	<b>516-2041</b>
VT1100D2 Shadow 1100 ACE	1999	<b>516-1041</b>	<b>516-2041</b>
VT1100T Shadow 1100 ACE Tourer	98-01	<b>516-1041</b>	<b>516-2041</b>
GL1200 Goldwing	1984	<b>516-1041</b>	<b>516-2041</b>
GL1200A Goldwing Aspencade	84-87	<b>516-1041</b>	<b>516-2041</b>
GL1200I Goldwing Interstate	84-87	<b>516-1041</b>	<b>516-2041</b>
GL1200L Goldwing LTD	1985	<b>516-1041</b>	<b>516-2041</b>
GL1200SEi Goldwing SEi	1986	<b>516-1041</b>	<b>516-2041</b>
ST1300	03-06	<b>516-1048</b>	_____
ST1300A (ABS)	03-06	<b>516-1048</b>	_____
VTX1300C	04-06	<b>516-1041</b>	<b>516-2041</b>
VTX1300R	05-06	<b>516-1041</b>	<b>516-2041</b>
VTX1300S	03-06	<b>516-1041</b>	<b>516-2041</b>
GL1500 Goldwing	88-90	<b>516-1041</b>	<b>516-2041</b>
GL1500A Goldwing Aspencade	91-00	<b>516-1041</b>	<b>516-2041</b>
GL1500I Goldwing Interstate	91-96	<b>516-1041</b>	<b>516-2041</b>
GL1500SE Goldwing SE	90-00	<b>516-1041</b>	<b>516-2041</b>
GL1500C Valkyrie	97-00	<b>516-1048</b>	<b>516-2048</b>
GL1500C Valkyrie	2003	<b>516-1048</b>	<b>516-2048</b>
GL1500CD Valkyrie	01-03	<b>516-1048</b>	<b>516-2048</b>
GL1500CF Valkyrie Interstate	99-01	<b>516-1048</b>	<b>516-2048</b>
GL1500CT Valkyrie Tourer	97-00	<b>516-1048</b>	<b>516-2048</b>
GL1800 Goldwing	01-06	<b>516-1048</b>	_____
GL1800A Goldwing	01-06	<b>516-1048</b>	_____
VTX1800C	02-03	<b>516-1048</b>	_____
VTX1800C1/C2/C3	2005	_____	_____
VTX1800F1/F2/F3	2005	_____	_____
VTX1800N1/N2/N3	04-05	<b>516-1048</b>	_____
VTX1800R	02-03	<b>516-1048</b>	_____
VTX1800R1/R2/R3	04-05	<b>516-1048</b>	_____
VTX1800S	02-03	<b>516-1048</b>	_____
VTX1800S1/S2/S3	04-05	<b>516-1048</b>	_____

## Honda ATV

ATC185S	1983	<b>516-1007</b>	_____
ATC200	1983	<b>516-1007</b>	_____
ATC200M	84-85	<b>516-1007</b>	_____
ATC200S	84-86	<b>516-1007</b>	_____
ATC200X	84-87	<b>516-1015</b>	_____
ATC250ES	85-87	<b>516-1015</b>	_____
ATC250R	81-82	<b>516-1007</b>	_____
ATC250R	83-84	<b>516-1020</b>	_____
ATC250R	85-86	<b>516-1035</b>	_____
ATC250SX	85-87	<b>516-1014</b>	_____
ATC350X	85-86	<b>516-1020</b>	_____

## Honda Dual Sport & Offroad

CR60R	1983	<b>516-1005</b>	_____
CR60R	1984	<b>516-1007</b>	_____
SL70K/K1	71-73	<b>516-1005</b>	_____
XL70K/K1	74-76	<b>516-1005</b>	_____
XR70R	97-03	<b>516-1005</b>	_____
CRF70F	04-07	<b>516-1005</b>	_____
XL75	77-79	<b>516-1005</b>	_____
XR75/K	73-78	<b>516-1005</b>	_____
CR80R	80-81	<b>516-1007</b>	_____
CR80R	82-83	<b>516-1008</b>	_____
CR80R	84-86	<b>516-1015</b>	_____
CR80R	87-95	<b>516-1020</b>	_____
CR80R	96-02	<b>516-1030</b>	_____
CR80RB Big Wheel	96-02	<b>516-1030</b>	_____
CRF80F	04-07	<b>516-1005</b>	_____
XL80S	80-85	<b>516-1005</b>	_____
XR80	79-84	<b>516-1005</b>	_____

## Honda Dual Sport & Offroad

Model	Year	Fork Seal Kit	Dust Seal Kit
XR80R	85-03	<b>516-1005</b>	_____
CR85R	03-07	<b>516-1030</b>	_____
CR85RB Big Wheel	03-07	<b>516-1030</b>	_____
EZ90	91-95	<b>516-1005</b>	_____
CRF100F	04-07	<b>516-1005</b>	_____
SL100K/K1 Moto Sport up to frame 21738	70-71	<b>516-1008</b>	_____
SL100K1/K2/K3 Moto Sport from frame 21739	71-73	<b>516-1010</b>	_____
XL100K/K1	74-75	<b>516-1010</b>	_____
XL100	76-78	<b>516-1010</b>	_____
XL100S up to frame 5103463	79-80	<b>516-1010</b>	_____
XL100S from frame 5103464	1980	<b>516-1008</b>	_____
XL100S	81-85	<b>516-1005</b>	_____
XR100	81-84	<b>516-1005</b>	_____
XR100R	85-03	<b>516-1005</b>	_____
CT125 Trail 125	1977	<b>516-1010</b>	_____
CR125M1	74-75	<b>516-1010</b>	_____
CR125M	76-78	<b>516-1020</b>	_____
CR125R	79-80	<b>516-1027</b>	_____
CR125R	81-82	<b>516-1031</b>	_____
CR125R	83-89	<b>516-1044</b>	_____
CR125R	90-91	<b>516-1048</b>	<b>516-2048</b>
CR125R	92-93	<b>516-1049</b>	<b>516-2049</b>
CR125R	94-96	<b>516-1046</b>	<b>516-2046</b>
CR125R	97-99	<b>516-1050</b>	<b>516-2050</b>
CR125R	00-06	<b>516-1050</b>	_____
MT125K/K1 Elsinore	74-76	<b>516-1010</b>	_____
NX125	88-90	<b>516-1020</b>	_____
SL125K1/K2 Moto Sport	71-73	<b>516-1010</b>	_____
TL125K/K1/K2	73-75	<b>516-1010</b>	_____
TL125S Trials	1976	<b>516-1010</b>	_____
XL125/K1	74-75	<b>516-1010</b>	_____
XL125	76-78	<b>516-1010</b>	_____
XL125S up to frame 5005875	79-80	<b>516-1010</b>	_____
XL125S from frame 5005876	80-82	<b>516-1009</b>	_____
XL125S	1984	<b>516-1009</b>	_____
XL125S	1985	<b>516-1008</b>	_____
CRF150F	03-07	<b>516-1020</b>	_____
MR175 Elsinore	75-77	<b>516-1010</b>	_____
SL175/K1 Moto Sport	70-72	<b>516-1008</b>	_____
XL175K/K1/K2	73-75	<b>516-1010</b>	_____
XL175	76-78	<b>516-1010</b>	_____
XL185S up to frame 5006890	79-80	<b>516-1010</b>	_____
XL185S from frame 5006891	80-83	<b>516-1009</b>	_____
XR185	1979	<b>516-1009</b>	_____
TLR200 Reflex	86-87	<b>516-1014</b>	_____
TR200 Fatcat	86-87	<b>516-1008</b>	_____
XL200R	83-84	<b>516-1014</b>	_____
XR200	80-84	<b>516-1008</b>	_____
XR200R	81-83	<b>516-1020</b>	_____
XR200R	84-88	<b>516-1025</b>	_____
XR200R	90-02	<b>516-1025</b>	_____
CRF230F	03-07	<b>516-1030</b>	_____
CR250R	78-80	<b>516-1027</b>	_____
CR250R	1981	<b>516-1040</b>	_____
CR250R	1982	<b>516-1047</b>	_____
CR250R	83-88	<b>516-1044</b>	_____
CR250R	89-91	<b>516-1048</b>	<b>516-2048</b>
CR250R	92-94	<b>516-1049</b>	<b>516-2049</b>
CR250R	1995	<b>516-1046</b>	<b>516-2046</b>
CR250R	1996	<b>516-1050</b>	<b>516-2050</b>
CR250R	97-00	<b>516-1053</b>	<b>516-2053</b>
CR250R	01-07	<b>516-1053</b>	_____
CRF250R	04-07	<b>516-1053</b>	_____
CRF250X	04-06	<b>516-1053</b>	_____
MT250/K/K1 Elsinore	74-76	<b>516-1020</b>	_____
MR250 Elsinore	1976	<b>516-1020</b>	_____
NX250	88-90	<b>516-1030</b>	_____
XL250K/K1/K2 Moto Sport	72-75	<b>516-1020</b>	_____
XL250	1976	<b>516-1020</b>	_____
XL250S	80-81	<b>516-1020</b>	_____

VINTAGE  
INTAKE  
ENGINE  
SUSPENSION  
CONTROL  
ELECTRICAL  
CHEMICAL  
TOOLS  
WATERCRAFT

# Fork Seals & Dust Seal Kits

## Honda Dual Sport & Offroad

Model	Year	Fork Seal Kit	Dust Seal Kit
XL250R	82-83	516-1020	-----
XL250R	84-86	516-1019	-----
XL250R	1987	516-1020	-----
XR250	79-80	516-1020	-----
XR250L	91-96	516-1041	-----
XR250R	81-82	516-1030	-----
XR250R	84-85	516-1044	-----
XR250R	86-04	516-1038	-----
SL350/K1 Moto Sport	70-71	516-1014	-----
SL350K2 Moto Sport	1972	516-1020	-----
XL350K/K1	74-75	516-1020	-----
XL350	76-78	516-1020	-----
XL350R	84-85	516-1035	-----
XR350R	83-85	516-1041	-----
XR400R	96-04	516-1044	-----
CR450R	1981	516-1040	-----
CRF450R	02-07	516-1053	-----
CRF450X	05-07	516-1053	-----
CR480R	1982	516-1047	-----
CR480R	1983	516-1044	-----
CR500R	84-88	516-1044	-----
CR500R	89-91	516-1048	516-2048
CR500R	92-94	516-1049	516-2049
CR500R	1995	516-1046	516-2046
CR500R	96-01	516-1050	516-2050
XL500R	1982	516-1030	-----
XL500S	79-81	516-1020	-----
XR500	79-80	516-1020	-----
XR500R	81-82	516-1030	-----
XR500R	83-84	516-1044	-----
XL600R	83-87	516-1035	-----
XL600V Transalp	89-90	516-1041	-----
XR600R	85-00	516-1044	-----
NX650	88-89	516-1041	516-2041
XR650L	93-09	516-1044	-----
XR650R	00-07	516-1051	-----

## Kawasaki Street

AR50A1	1982	516-1005	-----
AR80A1	1982	516-1005	-----
G3SS/A/B/C/D-90	69-73	516-1005	-----
G3TR90	69-70	516-1005	-----
GSSSE100	1975	516-1005	-----
KH100B7/B8	76-77	516-1005	-----
EL250B2/B3 Eliminator	88-89	516-1026	-----
EL250E1/E2/E3/E4	91-94	516-1026	-----
EX250E1/E2 Ninja 250R	86-87	516-1020	-----
EX250F2/F3/F4 Ninja 250R	88-90	516-1026	-----
EX250F6-F19 Ninja 250R	92-05	516-1026	-----
EX250F6F Ninja 250R	2006	516-1026	-----
KE250B1/B2/B3	77-79	516-1019	-----
KL250A1/A2	78-79	516-1019	-----
KL250A3/A4/A5	80-82	516-1025	-----
KL250C1/C2	83-84	516-1025	-----
KL250D2-D22 KLR Dual Sport	85-05	516-1025	-----
KLX250H6F Dual Sport	2006	516-1046	-----
KZ250D1/D2 LTD & CSR	80-81	516-1010	-----
KZ250L1 CSR	1982	516-1008	-----
KZ250W1 LTD	1982	516-1008	-----
S1A/B/C-250 (2-stroke triple)	73-75	516-1016	-----
KH250A5 (2-stroke triple)	1976	516-1016	-----
EX305B1 GPz	1983	516-1008	-----
KZ305A1/A2 CSR	81-82	516-1015	-----
KZ305B1 CSR	1982	516-1015	-----
KZ305B2/B3 LTD	87-88	516-1015	-----
S2/S2A-350 (2-stroke triple)	72-73	516-1016	-----
KZ400A1/A2 Deluxe	77-78	516-1015	-----
KZ400B1/B2	78-79	516-1015	-----
KZ400C1	1978	516-1015	-----
KZ400D/D3/D4	75-77	516-1015	-----
KZ400H1 LTD	1979	516-1015	-----

## Kawasaki Street

Model	Year	Fork Seal Kit	Dust Seal Kit
S3/S3A-400 (2-stroke triple)	74-75	516-1016	-----
KH400A3/A4/A5 (2-stroke triple)	76-78	516-1016	-----
KZ440A1/A2/A3/A4 LTD	80-83	516-1015	-----
KZ440B1/B2	80-81	516-1015	-----
KZ440D1-D5 LTD Belt	80-83	516-1015	-----
KZ440G1 Belt	1982	516-1015	-----
EN450A1-A6 454 LTD	85-00	516-1026	-----
EN500A1-A7 Vulcan 500	90-96	516-1026	-----
EN500C1-C10 Vulcan 500 LTD	96-05	516-1038	-----
EN500C6F Vulcan 500 LTD	2006	516-1038	-----
EX500A1-A7	87-93	516-1026	-----
EX500D1/D2/D3 Ninja 500	94-96	516-1030	-----
EX500D4-D12 Ninja 500R	97-05	516-1030	-----
EX500D6F/D7F Ninja 500R	06-07	516-1030	-----
H1/H1A/C-500 Mach III	69-72	516-1016	-----
H1B-500 2-stroke triple with points Ign.	1972	516-1025	-----
H1D/E/F-500 (2-stroke triple)	73-75	516-1025	-----
KH500A8 (2-stroke triple)	1976	516-1025	-----
KZ550A1/A2/A3/A4	80-83	516-1026	-----
KZ550C1/C2/C3/C4 LTD	80-83	516-1026	-----
KZ550D1 GPz	1981	516-1026	-----
KZ550F1 Spectre	1983	516-1024	-----
KZ550F2 LTD	1984	516-1024	-----
KZ550H1/H2 GPz	82-83	516-1020	-----
KZ550M1 LTD	1983	516-1024	-----
ZR550B1/B2/B3/B4 Zephyr	90-93	516-1034	-----
ZX550A1/A2 GPz	84-85	516-1020	-----
KL600A1 KLR600	1984	516-1031	-----
KL600B1/B2 KLR600	85-86	516-1031	-----
ZL600A1/A2 Eliminator	86-87	516-1029	-----
ZL600B2/B3 Eliminator	96-97	516-1029	-----
ZX600A1/A2/A3 Ninja 600R	85-87	516-1029	-----
ZX600B1 Ninja 600RX	1987	516-1029	-----
ZX600C1-C10 Ninja 600R	88-97	516-1032	-----
ZX600D1-D4 Ninja ZX-6	90-93	516-1041	516-2041
ZX600E1-E10 Ninja ZX-6	93-02	516-1041	516-2041
ZX600E11/E12 ZZR600	03-04	516-1041	516-2041
ZX600F1/F2/F3 Ninja ZX-6R	95-97	516-1037	-----
ZX600G1/G2 Ninja ZX-6R	98-99	516-1070	-----
ZX600J1/J2/J3 Ninja ZX-6R	00-02	516-1070	-----
ZX600J4 ZZR600	2005	516-1070	-----
ZX600K1/K1L Ninja ZX-6RR	2003	516-1039	-----
ZX600M1 Ninja ZX-6RR	2004	516-1039	-----
ZX600N1 Ninja ZX-6RR	2005	516-1041	-----
ZX600N6F Ninja ZX-6RR	2006	-----	-----
ZX636B1/B2 Ninja ZX-6R	03-04	516-1039	-----
ZX636C1 Ninja ZX-6R	2005	-----	-----
ZX636C6F Ninja ZX-6R	2006	-----	-----
ZX636D6F Ninja ZX-6R	2006	-----	-----
EJ650A2/A3 W650 Twin	00-01	516-1034	-----
KL650A1-A19 KLR650	87-05	516-1031	-----
KL650A6F/A7F KLR650	06-07	516-1031	-----
KL650B2 Tengai KLR	1990	516-1031	-----
KLX650C1-C4 Dual Sport	93-96	516-1046	516-2046
KZ650B1/B2/B2A/B3	77-79	516-1025	-----
KZ650C1/C2/C3 Custom	77-79	516-1025	-----
KZ650D1/D1A/D2 SR	78-79	516-1025	-----
KZ650E1 LTD	1980	516-1025	-----
KZ650F1	1980	516-1025	-----
KZ650H1/H2/H3 CSR	81-83	516-1024	-----
KZ700A1	1984	516-1024	-----
VN700A1 Vulcan	1985	516-1033	-----
ZN700A1/A2 LTD	84-85	516-1024	-----
H2/A/B/C-750 (2-stroke triple)	72-75	516-1025	-----
KZ750B1/B2/B3/B4 (2cyl.)	76-79	516-1025	-----
KZ750E1/E2/E3	80-82	516-1024	-----
KZ750F1 LTD	1983	516-1026	-----
KZ750G1 LTD (2cyl.)	1980	516-1025	-----
KZ750H1/H2/H3/H4 LTD	80-83	516-1024	-----
KZ750K1/K2 LTD (2cyl.)	83-84	516-1024	-----

## Kawasaki Street

Model	Year	Fork Seal Kit	Dust Seal Kit
KZ750L3	1983	516-1024	_____
KZ750M1 CSR (2cyl.)	1982	516-1024	_____
KZ750N1/N2 Spectre	82-83	516-1026	_____
KZ750R1 GPz	1982	516-1024	_____
VN750A1-A21 Vulcan 750	86-05	516-1033	_____
VN750A6F Vulcan 750	2006	516-1033	_____
ZR750C1/C2/C3 Zephyr	91-93	516-1038	_____
ZR750F2 ZR-7	2000	516-1039	_____
ZR750H1/H2/H3 ZR-7S	01-03	516-1039	_____
ZR750K1/K6F Z750S	05-06	516-1039	_____
ZX750A1/A2/A3 GPz	83-85	516-1029	_____
ZX750E1/E2 GPz Turbo	84-85	516-1029	_____
ZX750F1-F4 Ninja 750R	87-90	516-1032	_____
ZX750H1/H2 Ninja ZX-7	89-90	516-1046	_____
ZX750J1/J2 Ninja ZX-7	91-92	516-1046	_____
ZX750K1/K2 Ninja ZX-7R	91-92	516-1038	_____
ZX750L1/L2/L3 Ninja ZX-7	93-95	516-1038	_____
ZX750M1/M2 Ninja ZX-7R	93-94	516-1038	_____
ZX750N1/N2 Ninja ZX-7RR	96-97	516-1046	_____
ZX750P1-P8 Ninja ZX-7R	96-03	516-1046	_____
VN800A1-A11 Vulcan 800	95-05	516-1041	516-2041
VN800B1-B10 Vulcan Classic	96-05	516-1041	516-2041
VN800C1/C2 Vulcan Drifter	99-00	516-1041	516-2041
VN800E1-E6F Vulcan Drifter	01-06	516-1041	516-2041
KZ900A4/A5	76-77	516-1025	_____
KZ900B1 LTD	1976	516-1025	_____
Z1/A/B-900	73-75	516-1025	_____
ZL900A1/A2 Eliminator	85-86	516-1033	_____
ZX900A1/A2/A3 Ninja	84-86	516-1032	_____
ZX900B1-B4 Ninja ZX-9R	94-97	516-1037	_____
ZX900C1/C2 Ninja ZX-9R	98-99	516-1070	_____
ZX900E1/E2 Ninja ZX-9R	00-01	516-1070	_____
ZX900F1/F2 Ninja ZX-9R	02-03	516-1070	_____
KZ1000A1/A2	77-78	516-1025	_____
KZ1000A3/A3A/A4 MKII	79-80	516-1025	_____
KZ1000B1/B2/B3/B4 LTD	77-80	516-1025	_____
KZ1000C1-C4 Police	78-81	516-1031	_____
KZ1000D1 Z1R	1978	516-1025	_____
KZ1000D3 Z1R	1980	516-1025	_____
KZ1000E1/E2 Shaft ST	79-80	516-1036	_____
KZ1000G1 LTD Classic	1980	516-1025	_____
KZ1000J1/J2/J3	81-83	516-1032	_____
KZ1000K1/K2 LTD	81-82	516-1032	_____
KZ1000M1/M2 CSR	81-82	516-1032	_____
KZ1000P1-P21 Police	82-02	516-1032	_____
KZ1000P24 Police	2005	516-1032	_____
KZ1000R1/R2 Replica	82-83	516-1032	_____
ZG1000A1-A13 Concours	86-98	516-1038	_____
ZG1000A14-A20 Concours	99-05	516-1039	_____
ZG1000A6F Concours	2006	516-1039	_____
ZL1000A1 Eliminator	1987	516-1033	_____
ZR1000A1/A2/A3 Z1000	03-05	516-1041	516-2041
ZX1000A1/A2 Ninja 1000R	86-87	516-1036	_____
ZX1000B1/B2/B3 Ninja ZX-10	88-90	516-1038	_____
ZX1000C1/C2 Ninja ZX-10R	04-05	516-1046	_____
ZX1000D6F Ninja ZX-10R	2006	_____	_____
KZ1100A1/A2/A3 Shaft	81-83	516-1032	_____
KZ1100B1/B2 GPz	81-82	516-1032	_____
KZ1100D1/D2 Spectre	82-83	516-1032	_____
KZ1100L1 LTD	1983	516-1032	_____
ZN1100B1/B2 LTD	84-85	516-1032	_____
ZR1100A1/A2/A3	92-94	516-1046	_____
ZR1100C3/C4 ZRX1100	99-00	516-1046	_____
ZX1100A1/A2 GPz	83-84	516-1029	_____
ZX1100C Ninja ZX-11	90-93	516-1046	_____
ZX1100D1-D9 Ninja ZX-11	93-01	516-1046	_____
ZX1100E1/E2/E3 GPz	95-97	516-1038	_____
ZX1100F1 GPz (ABS)	1996	516-1038	_____
ZG1200A1 Voyager XII	1986	516-1041	516-2041
ZG1200B Voyager XII	87-03	516-1041	516-2041
ZR1200A1-A5 ZRX1200	01-05	516-1046	_____

## Kawasaki Street

Model	Year	Fork Seal Kit	Dust Seal Kit
ZX1200A1/A2 Ninja ZX-12R	00-01	516-1046	_____
ZX1200B1-B4 Ninja ZX-12R	02-05	516-1046	_____
ZX1200C1-C4 ZZR1200	02-05	516-1046	_____
KZ1300A1/A2/A3/A4	79-82	516-1038	_____
KZ1300B2 Touring	1980	516-1038	_____
ZN1300A1-A6 Voyager	83-87	516-1038	_____
VN1500A1-A9 Vulcan 88	87-95	516-1041	516-2041
VN1500A10-A12 Vulcan	96-98	516-1041	516-2041
VN1500B1-B4 Vulcan 88SE	87-90	516-1041	516-2041
VN1500C3/C4 Vulcan 1500L	96-97	516-1041	516-2041
VN1500D1-D3 1500 Classic	96-98	516-1041	516-2041
VN1500E1-E8 Vulcan Classic	98-05	516-1041	516-2041
VN1500G1 Vulcan Nomad	1999	516-1041	516-2041
VN1500G1A Vulcan Nomad	1999	516-1041	516-2041
VN1500G2A Vulcan Nomad	2000	516-1041	516-2041
VN1500J1/J2 Vulcan Drifter	99-00	516-1041	516-2041
VN1500L1-L5 Nomad FI	00-04	516-1041	516-2041
VN1500N1 Vulcan Classic FI	2000	516-1041	516-2041
VN1500P1/P2 Mean Streak	02-03	516-1044	_____
VN1500R3/R4 Vulcan Drifter	03-04	516-1041	516-2041
VN1600A1/A2 Vulcan 1600 Classic	03-04	516-1046	_____
VN1600A3/A6F Vulcan 1600 Classic	05-06	516-1046	_____
VN1600E6F Vulcan 1600 Classic	2006	516-1046	_____
VN1600B1/B2 Vulcan 1600 Mean Streak	04-05	_____	_____
VN1600B6F Vulcan 1600 Mean Streak	2006	_____	_____
VN1600F6F Vulcan 1600 Mean Streak	2006	_____	_____
VN1600D1/D6F Vulcan 1600 Nomad	05-06	516-1046	_____
VN1600G6F Vulcan 1600 Nomad	2006	516-1046	_____

## Kawasaki ATV

KLT110A2/A3	85-86	516-1007	_____
KLT160A1	1985	516-1007	_____
KLT185A1/A2 Bayou	86-87	516-1007	_____
KXT250A1/A2 Tecate 3	84-85	516-1025	_____
KXT250B1/B2 Tecate 3	86-87	516-1040	_____

## Kawasaki Dual Sport & Offroad

KX60A1/A2	83-84	516-1007	_____
KX60B1-B19	85-03	516-1007	_____
KX65A1-A7F	00-07	516-1015	_____
KD80/A2	75-76	516-1005	_____
KD80M1-M8	80-87	516-1005	_____
KD80N1/N2/N3	88-90	516-1005	_____
KDX80A1/A2/B2/B3	80-83	516-1007	_____
KDX80C1/C2/C3/C4/C5	84-88	516-1007	_____
KX80A1/A2/C1	79-81	516-1007	_____
KX80C2	1982	516-1008	_____
KX80E1	1983	516-1014	_____
KX80E2/E3	84-85	516-1013	_____
KX80G1/G2	86-87	516-1019	_____
KX80J2 Big Wheel	1987	516-1019	_____
KX80L1/L2/L3	88-90	516-1019	_____
KX80N1/N2/N3 Big Wheel	88-90	516-1019	_____
KX80R1	1991	516-1019	_____
KX80R2/R3/R4/R5/R6/R7	92-97	516-1031	_____
KX80T1 Big Wheel	1991	516-1019	_____
KX80T2/T3/T4	92-94	516-1024	_____
KX80W1/W2/W3	98-00	516-1024	_____
KX85A1-A7F	01-07	516-1024	_____
G3TR90	69-70	516-1005	_____
MC1/MC1A/MC1B-90	73-75	516-1005	_____
G3TRA100	1971	516-1005	_____
G31M/G31MA-100	70-71	516-1006	_____
G4TR/A-100 Trail Boss	70-71	516-1006	_____
G4TRB/C/D/E-100	72-75	516-1006	_____
G5/G5A/G5B/G5C-100	72-75	516-1006	_____
KE100M1/M2/M3/M4	76-79	516-1005	_____
KE100A5-A10	76-81	516-1006	_____
KE100B1-B20	82-01	516-1006	_____

# Fork Seals & Dust Seal Kits

## Kawasaki Dual Sport & Offroad

Model	Year	Fork Seal Kit	Dust Seal Kit
KM100A1-A7	76-81	516-1005	—
KV100A7	1976	516-1006	—
KX100B5/B6/B7	95-97	516-1024	—
KX100C1/C2/C3	98-00	516-1024	—
KX100D1-D7F	01-07	516-1024	—
KLX110A1/A2/A3/A4/A6F/A7F	02-07	516-1007	—
C2SS120/C2TR-120	67-68	516-1005	—
C2SS120/C2TR-120	1969	516-1006	—
F6/A/B-125	71-73	516-1006	—
KD125/A2/A3/A4/A5	75-79	516-1010	—
KS125/A	74-75	516-1010	—
KE125A3-A10	76-83	516-1010	—
KLX125A1/A2/A3	03-05	516-1007	—
KLX125B1/B2/B3	03-05	516-1007	—
KX125A/A3	74-76	516-1010	—
KX125A4/A5	78-79	516-1025	—
KX125A6/A7	80-81	516-1031	—
KX125B1	1982	516-1040	—
KX125B2/C1/D1/E1/E2	83-87	516-1047	—
KX125F1	1988	516-1046	—
KX125G1	1989	516-1051	—
KX125H1	1990	516-1038	516-2038
KX125H2/J1/J2/K1/K2	91-95	516-1046	516-2046
KX125K3/K4/K5/L1	96-99	516-1050	516-2050
KX125L2/L3	00-01	516-1050	—
KX125L4/M1/M2/M3	02-05	516-1071	516-2071
F3-175 Bushwhacker	68-70	516-1006	—
F7/A/B/C/D-175 Enduro	71-75	516-1006	—
KD175A1/A2/A3/A4	76-79	516-1011	—
KDX175A1/A2/A3	80-82	516-1025	—
KE175B1/B2/B3	76-78	516-1011	—
KE175D2/D3/D4/D5	80-83	516-1020	—
KDX200A1/A2/A3	83-85	516-1031	—
KDX200C1/C2/C3	86-88	516-1047	—
KDX200E1/E2/E3/E4	89-92	516-1047	—
KDX200E5/E6	93-94	516-1038	516-2038
KDX200H1-H11	95-05	516-1046	—
KDX200H6F	2006	516-1046	—
KDX220A4-A12	97-05	516-1046	—
F4-250	68-70	516-1016	—
F8/F8A-250	71-72	516-1016	—
F11/A/B-250	73-75	516-1016	—
F11M250	1973	516-1018	—
KDX250A1	1980	516-1031	—
KDX250B1/B2/B3/B4	81-84	516-1031	—
KDX250D1/D2/D3/D4	91-94	516-1046	516-2046
KE250B1/B2/B3	77-79	516-1019	—
KL250A1/A2	78-79	516-1019	—
KL250A3/A4/A5	80-82	516-1025	—
KL250C1/C2	83-84	516-1025	—
KL250D2-D22 KLR	85-05	516-1025	—
KLX250A1/A2	79-80	516-1025	—
KLX250D2/D3/D4	94-96	516-1046	516-2046
KLX250H6F Dual Sport	2006	516-1046	—
KT250A/A2 Trials	75-76	516-1016	—
KX250/A/A3	74-76	516-1025	—
KX250A4	1978	516-1025	—
KX250A5/A6/A7	79-81	516-1031	—
KX250B1	1982	516-1040	—
KX250C1/C2/D1/D2/E1	83-87	516-1047	—
KX250F1	1988	516-1046	—
KX250G1	1989	516-1051	—
KX250H1	1990	516-1038	516-2038
KX250H2/J1/J2/K1/K2	91-95	516-1046	516-2046
KX250K3/K4/K5/L1/L2/L3	96-01	516-1050	516-2050
KX250L4/M1/M2	02-04	516-1071	516-2071
KX250R1/R6F/R7F	05-07	—	516-2071
KX250N1 KX250F	2004	516-1071	516-2071

## Kawasaki Dual Sport & Offroad

Model	Year	Fork Seal Kit	Dust Seal Kit
KX250N2 KX250F	2005	—	—
KX250N6F/N7F KX250F	06-07	—	—
KLX300A2-A10	97-05	516-1046	—
KLX300A6F/A7F	06-07	516-1046	—
F5/F5A 350 Bighorn	70-71	516-1016	—
F9/A/B/C350	72-75	516-1016	—
KDX400A1/A2	79-80	516-1031	—
KLX400A1 KLX400SR Dual	2003	516-1052	516-2052
KX400B1 KLX400R Offroad	2003	516-1052	516-2052
KX400/A2	75-76	516-1025	—
KDX420B1	1981	516-1031	—
KX420A1/A2	80-81	516-1031	—
KDX450 A1	1982	516-1031	—
F12MX450	1973	516-1016	—
KX450	1974	516-1016	—
KX450D6F/D7F	06-07	—	516-2071
KX500A1/A2	83-84	516-1047	—
KX500B1/B2	85-86	516-1047	—
KX500C1	1987	516-1047	—
KX500D1	1988	516-1046	—
KX500E1	1989	516-1051	—
KX500E2	1990	516-1038	516-2038
KX500E3/E4/E5/E6/E7/E8	91-96	516-1046	516-2046
KX500E9-E16	97-04	516-1050	516-2050
KL600A1 KLR600	1984	516-1031	—
KL600B1/B2 KLR600	85-86	516-1031	—
KL650A1-A19 KLR650	87-05	516-1031	—
KL650A6F/A7F KLR650	06-07	516-1031	—
KL650B2 Tengai KLR	1990	516-1031	—
KLX650A1/A2/A3 KLX650R	93-95	516-1046	516-2046
KLX650C1-C4 Dual Sport	93-96	516-1046	516-2046
KLX650D1 KLX650R	1996	516-1046	516-2046



## KTM

Model	Year	Fork Seal Kit	Dust Seal Kit
50 SXR Adventure	97-99	516-1062K	516-2062K
50 SXR Pro Junior	97-99	516-1062K	516-2062K
50 SXR Pro Senior	97-99	516-1062K	516-2062K
50 SX Mini-Adventure	00-01	516-1062K	516-2062K
50 SX Junior-Adventure	00-01	516-1062K	516-2062K
50 SX Senior-Adventure	00-01	516-1062K	516-2062K
50 SX Pro Junior LC	02-04	516-1063K	516-2063K
50 SX Pro Senior LC	02-04	516-1063K	516-2063K
50 Mini-Adventure	02-04	516-1063K	516-2063K
50 Junior-Adventure	02-03	516-1063K	516-2063K
50 Senior-Adventure	02-04	516-1063K	516-2063K
60 SX	98-01	516-1062K	516-2062K
65 SX	98-01	516-1062K	516-2062K
65 SX	02-06	516-1021	516-2021K
80 MX Pro-mini	1986	516-1021	516-2021K
80/85 MX Super-mini	1986	516-1021	516-2021K
80/85 MX Pro-Lever	1986	516-1031	-----
85SX	03-06	516-1058K	-----
125 DXC	90-92	516-1057K	516-2057K
125 EGS	90-95	516-1057K	516-2057K
125 EGS	95-97	516-1054	516-2054K
125 EGS	1999	516-1060K	516-2060K
125 EXC	90-95	516-1057K	516-2057K
125 EXC	95-97	516-1054	516-2054K
125 EXC	1999	516-1060K	516-2060K
125 EXC	00-02	516-1058K	516-2058K
125 GS	1983	516-1031	-----
125 GS	85-86	516-1057K	516-2057K
125 MX	83-84	516-1036	-----
125 MX	85-86	516-1057K	516-2057K
125 MX	90-92	516-1057K	516-2057K
125 MX	1994	516-1057K	516-2057K
125 MX	1999	516-1060K	516-2060K
125 MX Enduro	87-90	516-1057K	516-2057K
125 MX Enduro	1988	516-1036	-----
125 MXC	83-84	516-1036	-----
125 MXC	85-86	516-1057K	516-2057K
125 MXC	00-02	516-1058	516-2058K
125 SGP-GS	00-02	516-1058K	516-2058K
125 SX	1993	516-1057K	516-2057K
125 SX	1995	516-1057K	516-2057K
125 SX	95-97	516-1054	516-2054K
125 SX	1999	516-1060K	516-2060K
125 SX	00-02	516-1058K	516-2058K
125 SX	02-06	516-1059K	516-2059K
200 SX/MXC/EXC/EGS	1999	516-1060K	516-2060K
200 SX/MXC/EXC/SGP-GS	00-02	516-1058K	516-2058K
200 SX/MXC/EXC Racing	02-06	516-1059K	516-2059K
240 MX Enduro	87-89	516-1057K	516-2057K
240 MX Enduro	1988	516-1036	-----
240 MX/MXC/GS	1986	516-1057K	516-2057K
250 DXC	90-92	516-1057K	516-2057K
250 EXC/EGS	90-95	516-1057K	516-2057K
250 EXC/EGS	95-96	516-1054	516-2054K
250 EXC/EGS	1997	516-1061K	516-2061K
250 EXC/EGS	98-99	516-1060K	516-2060K
250 EXC/EGS	00-02	516-1058K	516-2058K
250 EXC Racing	2002	516-1059K	516-2059K
250 GS	1983	516-1031	-----
250 GS	1984	516-1036	-----
250 GS	85-86	516-1057K	516-2057K
250 MX	83-84	516-1036	-----
250 MX	85-86	516-1057K	516-2057K
250 MX	90-92	516-1057K	516-2057K
250 MX Enduro	87-89	516-1057K	516-2057K
250 MX Enduro	1988	516-1036	-----
250 MXC	83-84	516-1036	-----
250 MXC	85-86	516-1057K	516-2057K
250 MXC	1994	516-1057K	516-2057K
250 MXC	95-96	516-1054	516-2054K
250 MXC	1997	516-1061K	516-2061K
250 MXC	98-99	516-1060K	516-2060K

## KTM

Model	Year	Fork Seal Kit	Dust Seal Kit
250 MXC	00-02	516-1058K	516-2058K
250 MXC Racing	2002	516-1059K	516-2059K
250 SX	93-95	516-1057K	516-2057K
250 SX	95-96	516-1054	516-2054K
250 SX	1997	516-1061K	516-2061K
250 SX	98-99	516-1060K	516-2060K
250 SX	00-02	516-1058K	516-2058K
250 SX Racing	02-06	516-1059K	516-2059K
300 DXC	90-92	516-1057K	516-2057K
300 EXC/EGS	90-95	516-1057K	516-2057K
300 EXC/EGS	95-96	516-1054	516-2054K
300 EXC/EGS	1997	516-1061K	516-2061K
300 EXC/EGS	98-99	516-1060K	516-2060K
300 EXC/EGS	00-02	516-1058K	516-2058K
300 EXC Racing	2002	516-1059K	516-2059K
300 GS	1986	516-1057K	516-2057K
300 MX	1986	516-1057K	516-2057K
300 MX	90-92	516-1057K	516-2057K
300 MXC	1986	516-1057K	516-2057K
300 MXC	94-95	516-1057K	516-2057K
300 MXC	95-96	516-1054	516-2054K
300 MXC	1997	516-1061K	516-2061K
300 MXC	98-99	516-1060K	516-2060K
300 MXC	00-02	516-1058K	516-2058K
300 MXC Racing	2002	516-1059K	516-2059K
300 SX	93-95	516-1057K	516-2057K
300 SX	95-96	516-1054	516-2054K
300 SX	1997	516-1061K	516-2061K
300 SX	98-99	516-1060K	516-2060K
300 SX	00-02	516-1058K	516-2058K
300 SX Racing	2002	516-1059K	516-2059K
300 TXC	1992	516-1057K	516-2057K
350 EXC/EGS	90-91	516-1057K	516-2057K
350 EXC/EGS	94-95	516-1057K	516-2057K
350 GSXC	1985	516-1057K	516-2057K
350 LC4 EXC	1994	516-1057K	516-2057K
350 MX	85-86	516-1057K	516-2057K
350 MX	90-91	516-1057K	516-2057K
350 MX	1994	516-1057K	516-2057K
350 MX Enduro	1987	516-1057K	516-2057K
350 MXC/GS	85-86	516-1057K	516-2057K
350 SX	1994	516-1057K	516-2057K
350 SX/Super Competition	1995	516-1057K	516-2057K
360 SX/EXC/MXC/EGS	1996	516-1054	516-2054K
360 SX/EXC/MXC/EGS	1997	516-1061K	516-2061K
380 SX/EXC/MXC/EGS	98-99	516-1060K	516-2060K
380 SX/EXC/MXC/EGS	00-02	516-1058K	516-2058K
380 SX/MXC/EXC Racing	2002	516-1059K	516-2059K
400 Duke	1995	516-1057K	516-2057K
400 EGS	94-95	516-1057K	516-2057K
400 EGSE	1997	516-1057K	516-2057K
400 EX	1995	516-1054	516-2054K
400 EX	1995	516-1057K	516-2057K
400 EXC	93-95	516-1057K	516-2057K
400 EXC	1995	516-1054	516-2054K
400 EXC Racing USA	2000	516-1058K	516-2058K
400 EXC Racing	00-02	516-1058K	516-2058K
400 LC4/Racing	98-00	516-1060K	516-2060K
400 LC4 EXC	93-94	516-1057K	516-2057K
400 LSE	1997	516-1057K	516-2057K
400 MXC	1995	516-1054	516-2054K
400 MXC	1995	516-1057K	516-2057K
400 MXC Racing	01-02	516-1058K	516-2058K
400 RXC	94-95	516-1057K	516-2057K
400 RXCE	94-95	516-1057K	516-2057K
400 RXCE	97-98	516-1057K	516-2057K
400 SX	1994	516-1057K	516-2057K
400 SX	00-01	516-1058K	516-2058K
400 SX	2002	516-1059K	516-2059K
400 SX Super Competition	1996	516-1054	516-2054K
400 SX Super Competition	95-96	516-1057K	516-2057K
400 SX Super Competition	97-98	516-1060K	516-2060K



# Fork Seals & Dust Seal Kits

VINTAGE  
INTAKE  
ENGINE  
SUSPENSION  
CONTROL  
ELECTRICAL  
CHEMICAL  
TOOLS  
WATERCRAFT

## KTM

Model	Year	Fork Seal Kit	Dust Seal Kit
400 SX Racing	00-02	516-1058K	516-2058K
400 SXC	1999	516-1060K	516-2060K
420 GS/MXC	1984	516-1057K	516-2057K
440 SX/EXC/MXC	94-95	516-1057K	516-2057K
440 SX/EXC/MXC	1995	516-1054	516-2054K
495 MX/MXC	1984	516-1057K	516-2057K
500 DXC/EGS	90-92	516-1057K	516-2057K
500 EC	1985	516-1057K	516-2057K
500 EXC	90-92	516-1057K	516-2057K
500 EXC	1995	516-1057K	516-2057K
500 EXC	1995	516-1054	516-2054K
500 GS	84-85	516-1057K	516-2057K
500 LC4 MX/EXC	1989	516-1057K	516-2057K
500 LC4 DXC/EXC/EGS	90-92	516-1057K	516-2057K
500 LC4 MX -Enduro	1988	516-1057K	516-2057K
500 MX	84-92	516-1057K	516-2057K
500 MX	1994	516-1057K	516-2057K
500 MX/MX Enduro	88-89	516-1036	---
500 MX Enduro	1987	516-1057K	516-2057K
500 MX Enduro	1989	516-1057K	516-2057K
500 MX LC4	90-91	516-1057K	516-2057K
500 MXC	85-86	516-1057K	516-2057K
500 MXC	1995	516-1054	516-2054K
500 SX	1993	516-1057K	516-2057K
500 SX	1995	516-1054	516-2054K
520 EXC	00-01	516-1058K	516-2058K
520 EXC	2002	516-1059K	516-2059K
520 EXC Racing	00-02	516-1058K	516-2058K
520 EXC Racing	2002	516-1059K	516-2059K
520 MXC	2002	516-1059K	516-2059K
520 MXC Racing	00-02	516-1058K	516-2058K
520 MXC Racing	2002	516-1059K	516-2059K
520 SX	00-01	516-1058K	516-2058K
520 SX	2002	516-1059K	516-2059K
520 SX Racing	00-02	516-1058K	516-2058K
520 SX Racing	2002	516-1059K	516-2059K
525 EXC Racing	03-06	516-1059K	516-2059K
525 MXC Racing	03-06	516-1059K	516-2059K
525 SX Racing	03-06	516-1059K	516-2059K
540 DXC	90-91	516-1057K	516-2057K
540 DXC	1994	516-1057K	516-2057K
540 SXC	1999	516-1060K	516-2060K
550 DXC	1992	516-1057K	516-2057K
550 EXC	1992	516-1057K	516-2057K
550 EXC	1995	516-1057K	516-2057K
550 EXC	1995	516-1054	516-2054K
550 MX	1992	516-1057K	516-2057K
550 MXC	93-96	516-1057K	516-2057K
550 MXC	95-96	516-1054	516-2054K
550 SX	1995	516-1057K	516-2057K
550 SX	1995	516-1054	516-2054K
600 DXC/EGS	90-92	516-1057K	516-2057K
600 Enduro LC4	1989	516-1057K	516-2057K
600 EXC	90-93	516-1057K	516-2057K
600 GS	1984	516-1057K	516-2057K
600 LC4	1997	516-1060K	516-2060K
600 LC4 DXC/EGS	90-92	516-1057K	516-2057K
600 LC4 EXC	89-93	516-1057K	516-2057K
600 LC4 MX	89-91	516-1057K	516-2057K
600 LC4 MX -Enduro	1988	516-1057K	516-2057K
600 MX	1984	516-1057K	516-2057K
600 MX	89-91	516-1057K	516-2057K
620 DUKE	95-97	516-1057K	516-2057K
620 EGSE	1997	516-1057K	516-2057K
620 EGSE Adventure	1997	516-1060K	516-2060K
620 EXC / EGS	94-95	516-1057K	516-2057K
620 LC4 Competiton	98-00	516-1060K	516-2060K
620 LC4 EXC	1994	516-1057K	516-2057K
620 LSE	1997	516-1057K	516-2057K
620 RXC	1996	516-1054	516-2054K
620 RXC/RXC LC4	94-95	516-1057K	516-2057K
620 RXCE	94-95	516-1057K	516-2057K

## KTM

Model	Year	Fork Seal Kit	Dust Seal Kit
620 RXCE	97-98	516-1057K	516-2057K
620 SC	97-98	516-1060K	516-2060K
620 SX	1994	516-1057K	516-2057K
620 SX	97-98	516-1060K	516-2060K
620 SX	1999	516-1060K	516-2060K
620 SX, Super Competition	95-96	516-1057K	516-2057K
620 SX, Super Competition	1996	516-1054	516-2054K
620 SX Super Competition	97-98	516-1060K	516-2060K
640 Adventure R	1999	516-1060K	516-2060K
640 DUKE	2000	516-1058K	516-2058K
640 LC4	98-00	516-1060K	516-2060K
640 LC4 E / LC4 Super Moto	00-01	516-1058K	516-2058K
640 LC4 R	1999	516-1060K	516-2060K
640 LC4 R Adventure	2000	516-1060K	516-2060K
640 LC4 Super Moto	1999	516-1060K	516-2060K

## Suzuki Street

Model	Year	Fork Seal Kit	Dust Seal Kit
RV90L/M/A/B Rover	74-77	516-1005	---
TC90	1970	516-1006	---
TC90R/J	71-72	516-1006	---
TS90	1970	516-1006	---
TS90R/J	71-72	516-1006	---
B100	65-67	516-1006	---
TC100K/L/M/A Blazer	73-77	516-1006	---
TS100K/L/M/A Honcho	73-77	516-1006	---
TS100C/N	78-79	516-1005	---
TS100T/X	80-81	516-1007	---
B105P	65-67	516-1006	---
KT120	65-67	516-1006	---
DR125SER/SES/SET Dual Sport	94-96	516-1020	---
GN125Z/D	82-83	516-1011	---
GN125EM-EV	91-97	516-1011	---
SP125Z/D	82-83	516-1010	---
SP125G/H/J	86-88	516-1020	---
TC125J/K/L/M/A/B Prospector	72-77	516-1006	---
TS125R/J/K/L/M/B Duster	71-77	516-1006	---
TS125C/N	78-79	516-1007	---
TS125T/X	80-81	516-1010	---
GT185K/L Adventurer	73-74	516-1006	---
GT185M/A/B	75-77	516-1007	---
TC185L/M/A/B Ranger	74-77	516-1006	---
TS185R/J/K/L/M/A Sierra	71-76	516-1006	---
TS185B/C	77-78	516-1006	---
TS185N/T/X	79-81	516-1011	---
DR200SET-SEK7 Dual Sport	96-07	516-1020	---
SP200G/H/J	86-88	516-1020	---
T200	65-69	516-1006	---
TC200	65-69	516-1006	---
DR250SL-SES Dual Sport	90-95	516-1044	---
GN250Z/D	82-83	516-1014	---
GN250F	1985	516-1014	---
GN250J	1988	516-1014	---
GS250TT/TX	80-81	516-1014	---
GT250K/L/M/A/B Hustler	73-77	516-1014	---
GZ250X/Y/K1-K7	99-07	516-1030	---
SP250Z/D	82-83	516-1020	---
SP250F	1985	516-1020	---
T250 (T20)	1969	516-1016	---
T250II/R/J	70-72	516-1016	---
TC250	1969	516-1016	---
TS250I Savage	1969	516-1019	---
TS250II Savage	1970	516-1016	---
TS250R/J/K/L/M/A	71-76	516-1016	---
TS250B/C/N	77-79	516-1020	---
TS250T/X	80-81	516-1024	---
GS300LZ/LD	82-83	516-1014	---
GS300LF	1985	516-1014	---
T305	1969	516-1016	---
TC305 Scrambler	1969	516-1016	---
DR350SL-SEX Dual Sport	90-99	516-1044	---
T350II/R/J	69-72	516-1016	---





## Suzuki Street

Model	Year	Fork Seal Kit	Dust Seal Kit
SP370C/N	78-79	516-1024	_____
GT380J/K/L/M/A/B Sebring	72-77	516-1014	_____
DR-Z400SMK5-K7 Supermotard	05-07	516-1053	_____
DR-Z400SY-SK7 Dual Sport	00-07	516-1052	516-2052
GN400T/XT/XX	80-81	516-1020	_____
GN400TX/TZ	81-82	516-1020	_____
GS400B/XB/C/XC	77-78	516-1015	_____
GS400M/N/P Bandit	91-93	516-1038	_____
SP400T Dual Sport	1980	516-1024	_____
TS400J-B Apache	71-77	516-1016	_____
GS425N/EN/LN	1979	516-1014	_____
GS450ET/EX/EZ/ED	80-83	516-1014	_____
GS450GAZ/GAD Automatic	82-83	516-1014	_____
GS450GAF Automatic	1985	516-1014	_____
GS450LT/LX/LZ	80-82	516-1014	_____
GS450LD	1983	516-1020	_____
GS450LF/LG/LH/LJ	85-88	516-1020	_____
GS450ST/SX	80-81	516-1014	_____
GS450TX/TZ	81-82	516-1014	_____
GS450TXZ/TXD	82-83	516-1014	_____
GS500EK-EK2	89-02	516-1029	_____
GS500FK4-FK6	04-06	_____	_____
GT500A/B Titan	76-77	516-1020	_____
RE5/RE5MA Rotary	75-76	516-1020	_____
SP500X/Z/D	81-83	516-1024	_____
T5001/2/3 Titan	68-70	516-1016	_____
T500R/J/K/L/M Titan	71-75	516-1016	_____
GS550B/C/EC	77-78	516-1020	_____
GS550N/EN/ET	79-80	516-1020	_____
GS550ED/ESD/EF	83-84	516-1029	_____
GS550ESF/ESG	85-86	516-1029	_____
GS550LN/LT/LX/LZ	79-82	516-1020	_____
GS550LD	1983	516-1030	_____
GS550LF	1985	516-1030	_____
GS550LG	1986	516-1020	_____
GS550MZ	1982	516-1020	_____
GS550TX	1981	516-1020	_____
GT550J/K/L/M/A/B Indy	72-77	516-1020	_____
XN85D Turbo	1983	516-1030	_____
GSF600ST/SV/SW Bandit	96-98	516-1038	_____
GSF600SX-SK3Bandit	99-03	516-1039	_____
GSX600FJ-FK6 Katana	88-06	516-1041	516-2041
GSX-R600WN/WP	92-93	516-1041	_____
GSX-R600V/W/X/Y/K1/K2/K3	97-03	516-1048	516-2048
GSX-R600K4/K5	04-05	516-1044	_____
RF600RR/RS/RT	94-96	516-1041	_____
DL650K4/K5/K6 V-Storm	04-06	516-1044	_____
DR650SL/SM/SN/SP	90-93	516-1038	_____
DR650SER/SES	94-95	516-1038	_____
DR650SET-SEK5 Dual	96-05	516-1047	_____
GR650D/XD Tempter	1983	516-1020	_____
SV650X/Y/K1/K2/K3/K4/K5	99-05	516-1038	_____
SV650SX/SY/SK1/SK2/SK3	99-03	516-1039	_____
SV650SK4/SK5	04-05	516-1039	_____
GS700EF/ESF	1985	516-1030	_____
GS650EX/EZ	81-82	516-1020	_____
GS650GX/GZ/GD	81-83	516-1020	_____
GS650GLX/GLZ/GLD	81-83	516-1020	_____
GS650MD Katana	1983	516-1030	_____
LS650FPG/FPH/FPJ Savage	86-88	516-1032	_____
LS650FFG/FFH Savage	86-87	516-1032	_____
LS650PT-PK4 Savage	96-04	516-1032	_____
LS650 Boulevard S40	05-07	516-1032	_____
GS700EF/ESF	1985	516-1030	_____
VS700GLFG/GLFH Intruder	86-87	516-1030	_____
VS700GLPG/GLPH Intruder	86-87	516-1030	_____
VS700GLEFG/GLEFH	86-87	516-1030	_____
VS700GLEPG/GLEPH	86-87	516-1030	_____
GS750B/C/EC/N	77-78	516-1020	_____
GS750EN/ET/EX/EZ	79-82	516-1020	_____
GS750ED/ESD	1983	516-1030	_____
GS750LN	1979	516-1030	_____

## Suzuki Street

Model	Year	Fork Seal Kit	Dust Seal Kit
GS750LT/LX	80-81	516-1020	_____
GS750TZ/TD	82-83	516-1020	_____
GS750SD Katana	1983	516-1029	_____
GSX750FK-FT Katana	89-96	516-1041	_____
GSX750FV-FK6 Katana	97-06	516-1041	516-2041
GSX-R750G/H	86-87	516-1038	_____
GSX-R750RG	1986	516-1038	_____
GSX-R750J/K/L	88-90	516-1044	_____
GSX-R750M/N	91-92	516-1041	_____
GSX-R750WP	1993	516-1041	_____
GSX-R750WR/WS	94-95	516-1044	_____
GSX-R750TV/W/X/Y	96-00	516-1044	_____
GSX-R750K1/K2/K3/K4/K5	01-05	516-1044	_____
GSX-R750K6	2006	_____	_____
GT750J/K/L/M/A/B Lemans	72-77	516-1020	_____
VS750GLPJ-GLPM Intruder	88-91	516-1035	_____
VL800K1-K4 Volusia	01-04	516-1041	_____
VL800 Boulevard C50	05-06	516-1041	_____
VL800 Boulevard C50T	2006	516-1041	_____
VS800GLN-GLK4 Intruder	92-04	516-1035	_____
VS800 Boulevard S50	05-06	516-1035	_____
VX800L/M/N/P	90-93	516-1038	_____
VZ800V-K3 Marauder	97-03	516-1038	_____
GS850GN/GT/GX/GZ/GD	79-83	516-1016	_____
GS850GLT/GLD	80-83	516-1016	_____
RF900RR/RS/RT/RV	94-97	516-1044	_____
RF900RZS	1995	516-1044	_____
DL1000K2-K6 V-Storm	02-06	516-1044	_____
GS1000C/N	78-79	516-1016	_____
GS1000EC/EN/ET	78-80	516-1029	_____
GS1000GT/GX	80-81	516-1029	_____
GS1000GLT/GLX	80-81	516-1029	_____
GS1000LN	1979	516-1029	_____
GS1000SN/ST	79-80	516-1029	_____
GS1000SZ	1982	516-1029	_____
GSX-R1000K1/K2/K3/K4	01-04	516-1046	_____
GSX-R1000K5/K6	05-06	_____	_____
SV1000K3/K4/K5	03-05	516-1070	_____
SV1000SK3/SK4/SK5/SK6/SK7	03-07	516-1070	_____
TL1000SV/SW/SX/SY/SK1	97-01	516-1046	_____
TL1000RW-RK2	98-02	516-1046	_____
GS1100ET/EX/EZ	80-82	516-1029	_____
GS1100ED/ESD	1983	516-1029	_____
GS1100GZ/GD	82-83	516-1029	_____
GS1100GLZ/GLD	82-83	516-1029	_____
GS1100GKZ/GK2	1982	516-1046	_____
GS1100GKD/GKE	83-84	516-1046	_____
GS1100LT	1980	516-1029	_____
GS1100SD Katana	1983	516-1029	_____
GSX1100GM/GN/GP Shaft	91-93	516-1046	_____
GSX1100FJ-FP Katana	88-93	516-1041	_____
GSX-R1100G/H/J	86-88	516-1037	_____
GSX-R1100K/L	89-90	516-1046	_____
GSX-R1100M/N	91-92	516-1038	_____
GSX-R1100WP/WR	93-94	516-1038	_____
GSX-R1100WS/WT/WV/WW	95-98	516-1046	_____
GS1150ES3/EF/EG	83-85	516-1029	_____
GS1150ESE/ESF/ESG	84-86	516-1029	_____
GS1150EF2	1985	516-1029	_____
GSF1200SV-SK6 Bandit	97-06	516-1044	_____
GSF1200SAV Bandit	1997	516-1044	_____
GV1200GLF/GLF2/GLG Madura	85-86	516-1038	_____
GSX1300RX-RK6 Hayabusa	99-06	516-1046	_____
GV1400GCG/GCH Calvacade	86-87	516-1046	_____
GV1400GDG/GDH/GDJ Calvacade	86-88	516-1046	_____
GV1400GTG/GTH Calvacade	86-87	516-1046	_____
VS1400GLFH Intruder	1987	516-1041	_____
VS1400GLPH-GLPK4 Intruder	87-04	516-1041	_____
VS1400 Boulevard S83	05-06	516-1041	_____
VL1500W-K4 Intruder 1500LC	98-04	516-1041	_____
VL1500LC Boulevard C90	05-06	516-1041	_____
VL1500LC Boulevard C90T	2006	516-1041	_____



# Fork Seals & Dust Seal Kits

## Suzuki Street

Model	Year	Fork Seal Kit	Dust Seal Kit
GS1150EF2	1985	516-1029	————
GSF1200SV-SK6 Bandit	97-06	516-1044	————
GSF1200SAV Bandit	1997	516-1044	————
GV1200GLF/GLF2/GLG Madura	85-86	516-1038	————
GSX1300RX-RK6 Hayabusa	99-06	516-1046	————
GV1400GCG/GCH Calvacade	86-87	516-1046	————
GV1400GDG/GDH/GDJ Calvacade	86-88	516-1046	————
GV1400GTG/GTH Calvacade	86-87	516-1046	————
VS1400GLFH Intruder	1987	516-1041	————
VS1400GLPH-GLPK4 Intruder	87-04	516-1041	————
VS1400 Boulevard S83	05-06	516-1041	————
VL1500W-K4 Intruder 1500LC	98-04	516-1041	————
VL1500LC Boulevard C90	05-06	516-1041	————
VL1500LC Boulevard C90T	2006	516-1041	————

## Suzuki Dual Sport & Offroad

RM60K3	2003	516-1007	————
RM65K3/K4/K5	03-05	516-1015	————
TM75L/M/A	74-76	516-1005	————
TS75M/A/B Colt	75-77	516-1005	————
RM80B/C	77-78	516-1005	————
RM80N-F	79-85	516-1007	————
RM80G/H/J	86-88	516-1014	————
RM80K-K1	89-01	516-1020	————
RM85K2/K3/K4/K5/K6/K7	02-07	516-1030	————
RM85LK2-LK7	02-07	516-1030	————
RV90L/M/A/B Rover	74-77	516-1005	————
TC90	1970	516-1006	————
TC90R/J	71-72	516-1006	————
TS90	1970	516-1006	————
TS90R/J	71-72	516-1006	————
DR100D-L	83-90	516-1007	————
DS100C/N/T/X	78-81	516-1005	————
RM100A/B/C	76-78	516-1006	————
RM100N/T/X	79-81	516-1020	————
RM100K3	2003	516-1024	————
TC100K/L/M/A Blazer	73-77	516-1006	————
TM100L/M	74-75	516-1006	————
TS100K/L/M/A Honcho	73-77	516-1006	————
TS100C/N	78-79	516-1005	————
TS100T/X	80-81	516-1007	————
DR-Z110K3/K4/K5	03-05	516-1007	————
DR125Z/D/E	82-84	516-1011	————
DR125G/H/J	86-88	516-1020	————
DR125SER/SES/SET	94-96	516-1020	————
DR-Z125K3/K4/K5/K6/K7	03-07	516-1007	————
DR-Z125LK3-/LK7	03-07	516-1007	————
DS125N/T/X	79-81	516-1007	————
RM125M/A	75-76	516-1020	————
RM125B/C	77-78	516-1024	————
RM125N/T/X/Z/D	79-83	516-1031	————
RM125E/F/G/H	84-87	516-1047	————
RM125J	1988	516-1046	————
RM125K	1989	516-1051	————
RM125L	1990	516-1038	516-2038
RM125M/N/P/R/S	91-95	516-1048	516-2048
RM125T/V/W/X/Y	96-00	516-1052	516-2052
RM125K1/K2/K3/K4	01-04	516-1053	516-2053
RM125K5/K6/K7	05-07	————	————
SP125Z/D	82-83	516-1010	————
SP125G/H/J	86-88	516-1020	————
TC125J/K/L/M/A/B Prospector	72-77	516-1006	————
TM125K/L/M	73-75	516-1006	————
TS125R/J/K/L/M/B Duster	71-77	516-1006	————
TS125C/N	78-79	516-1007	————

## Suzuki Dual Sport & Offroad

Model	Year	Fork Seal Kit	Dust Seal Kit
TS125T/X	80-81	516-1010	————
PE175C/N/T/X	78-81	516-1024	————
PE175Z/D/E	82-84	516-1031	————
RS175T/X/Z	80-82	516-1024	————
DS185C	1978	516-1006	————
DS185N/T	79-80	516-1011	————
TC185L/M/A/B Ranger	74-77	516-1006	————
TS185R/J/K/L/M/A Sierra	71-76	516-1006	————
TS185B/C	77-78	516-1006	————
TS185N/T/X	79-81	516-1011	————
DR200G/H/J	86-88	516-1020	————
DR200SET-SEK7 Dual Sport	96-07	516-1020	————
SP200G/H/J	86-88	516-1020	————
DR250Z/D	82-83	516-1024	————
DR250F	1985	516-1024	————
DR250L/M/N/P Offroad	90-93	516-1044	————
DR250SL-SES Dual Sport	90-95	516-1044	————
DR-Z250K1/K2/K3/K4/K5/K6	01-06	516-1044	————
DS250T	1980	516-1024	————
PE250B/C/N/T/X	77-81	516-1024	————
RL250L/M Trials	74-75	516-1020	————
RM250A/B/C/C2	76-78	516-1024	————
RM250N/T/X/Z	79-82	516-1031	————
RM250D/E/F/G/H	83-87	516-1047	————
RM250J	1988	516-1046	————
RM250K/L	89-90	516-1038	516-2038
RM250M/N/P/R/S	91-95	516-1048	516-2048
RM250T/V/W/X/Y	96-00	516-1052	516-2052
RM250K1/K2/K3	01-03	516-1050	516-2050
RM250K4	2004	516-1053	————
RM-Z250K4	2004	516-1071	516-2071
RMX250K/L	89-90	516-1038	516-2038
RMX250M-W	91-98	516-1048	516-2048
RS250T/X	80-81	516-1024	————
SP250Z/D	82-83	516-1020	————
SP250F	1985	516-1020	————
TM250J/K	72-73	516-1016	————
TM250L/M	74-75	516-1020	————
TS250I Savage	1969	516-1019	————
TS250II Savage	1970	516-1016	————
TS250R/J/K/L/M/A	71-76	516-1016	————
TS250B/C/N	77-79	516-1020	————
TS250T/X	80-81	516-1024	————
DR350L-X Offroad	90-99	516-1044	————
DR350SL-SEX Dual Sport	90-99	516-1044	————
DR370C/N	78-79	516-1024	————
RM370A/B	76-77	516-1024	————
SP370C/N	78-79	516-1024	————
DR400T	1980	516-1024	————
DR-Z400EY-EK7	00-07	516-1052	516-2052
DR-Z400SMK5-K7 Supermotard	05-07	516-1053	————
DR-Z400SY-SK7 Dual Sport	00-07	516-1052	516-2052
DR-Z400Y/K1/K2/K3/K4	00-04	516-1052	516-2052
PE400T/X	80-81	516-1024	————
RM400C	1978	516-1024	————
RM400N/T	79-80	516-1031	————
SP400T Dual Sport	1980	516-1024	————
TM400R/J Cyclone	71-72	516-1016	————
TM400K/L/M	73-75	516-1020	————
TS400J-B Apache	71-77	516-1016	————
RM465X/Z	81-82	516-1047	————
DR500X/Z/D	81-83	516-1024	————
RM500D/E	83-84	516-1047	————
SP500X/Z/D	81-83	516-1024	————
DR650SL-SES Dual Sport	90-95	516-1038	————
DR650SET-SEK7 Dual Sport	96-07	516-1047	————

## Triumph

Model	Year	Fork Seal Kit	Dust Seal Kit
Models with 43mm Forks		<b>516-1047</b>	---
Models with 45mm Forks		<b>516-1048</b>	---

## Yamaha Street

DT50U/W/A	88-90	<b>516-1006</b>	---
YSR50T/U/W/A/B/D	87-92	<b>516-1005</b>	---
HS1/HS1B-90	70-71	<b>516-1005</b>	---
DT100A/B/C	74-76	<b>516-1006</b>	---
DT100D-K	77-83	<b>516-1005</b>	---
LS2-100	1972	<b>516-1005</b>	---
RS100B/C	75-76	<b>516-1005</b>	---
AT1E125 Enduro	1969	<b>516-1006</b>	---
AT1B/AT1C/AT2/AT3-125 Enduro	70-73	<b>516-1006</b>	---
DT125A/B/C	74-76	<b>516-1006</b>	---
DT125E	1978	<b>516-1010</b>	---
DT125F/G/H	79-81	<b>516-1011</b>	---
TZ125G	1980	<b>516-1006</b>	---
XT125J/K/KC Dual Sport	83-83	<b>516-1011</b>	---
CT1/B/CT1C-175 Enduro	69-71	<b>516-1006</b>	---
CT2/CT3-175 Enduro	72-73	<b>516-1006</b>	---
DT175A/B/C	74-76	<b>516-1006</b>	---
DT175E	1978	<b>516-1010</b>	---
DT175F/G/H	79-81	<b>516-1011</b>	---
SR185H/J Exciter	81-82	<b>516-1007</b>	---
CS3C/CS3B-200	70-71	<b>516-1006</b>	---
CS5-200	1972	<b>516-1006</b>	---
RD200A/B/C	74-76	<b>516-1006</b>	---
TW200T/TC-VVC Trailway	87-06	<b>516-1013</b>	---
XT200J/K/KC Dual Sport	82-83	<b>516-1019</b>	---
XT225E/EC-VVC Serrow	93-06	<b>516-1026</b>	---
DS6C/DS6B-250	69-70	<b>516-1011</b>	---
DS7-250	1972	<b>516-1016</b>	---
DT1/DT1B/DT1C/DT1E-250 Enduro	68-71	<b>516-1016</b>	---
DT1S-250 Enduro	1969	<b>516-1016</b>	---
DT2/DT3-250 Enduro	72-73	<b>516-1016</b>	---
DT250A/B/C/D/E	74-78	<b>516-1016</b>	---
DT250F	1979	<b>516-1025</b>	---
RD250A/B	73-75	<b>516-1016</b>	---
SR250G/H/J Exciter	80-82	<b>516-1011</b>	---
SR250TH Exciter II	1981	<b>516-1011</b>	---
SRX250T/TC	1987	<b>516-1013</b>	---
TD3-250 (Roadrace)	1972	<b>516-1016</b>	---
TZ250 (Roadrace)	1973	<b>516-1016</b>	---
TZ250C/D/E (Roadrace)	76-78	<b>516-1019</b>	---
TZ250F (Roadrace)	1979	<b>516-1017</b>	---
XT250G/H/J/K/KC Dual Sport	80-83	<b>516-1019</b>	---
XT250L/LC Dual Sport	1984	<b>516-1025</b>	---
XV250U/UC/W/WC/A/AC Route 66	88-90	<b>516-1013</b>	---
XV250G/GC/H/HK/K/KC Route 66	95-98	<b>516-1013</b>	---
XV250L/LC Virago 250	1999	<b>516-1013</b>	---
XV250P/PC-VVC Virago 250	02-06	<b>516-1013</b>	---
R3-350	1969	<b>516-1016</b>	---
R5/R5B/R5C-350	70-72	<b>516-1016</b>	---
RD350A/B	73-75	<b>516-1016</b>	---
RZ350L/N/NC/NCII	84-85	<b>516-1020</b>	---
TR3 350 (Roadrace)	1972	<b>516-1016</b>	---
TZ350 (Roadrace)	1973	<b>516-1016</b>	---
TZ350C/D/E	76-78	<b>516-1019</b>	---
XT350N/NC-M/MC Dual Sport	85-00	<b>516-1025</b>	---
DT360A/B Enduro	74-75	<b>516-1016</b>	---
RT1/RT1B-360 Enduro	70-71	<b>516-1016</b>	---
RT2/RT3-360 Enduro	72-73	<b>516-1016</b>	---
XS360C/D/2D	76-77	<b>516-1014</b>	---
DT400B/C/D/E	75-78	<b>516-1016</b>	---
FZR400U/SUCW/SWC/A/SAC	88-90	<b>516-1032</b>	---

## Yamaha Street

Model	Year	Fork Seal Kit	Dust Seal Kit
RD400C/D/E	76-78	<b>516-1016</b>	---
RD400F	1979	<b>516-1019</b>	---
XS400D/E/2E/F/2F	77-79	<b>516-1014</b>	---
XS400G/H Special	80-81	<b>516-1014</b>	---
XS400J/K Maxim	82-83	<b>516-1020</b>	---
XS400RJ/RK Seca	82-83	<b>516-1020</b>	---
XS400SG/SH/SJ Special	80-82	<b>516-1014</b>	---
SR500E/F/G/H	78-81	<b>516-1019</b>	---
XT500C/D/E/F/G/H Dual Sport	76-81	<b>516-1025</b>	---
TX500/A	73-74	<b>516-1016</b>	---
XS500B	1975	<b>516-1016</b>	---
XS500C/D/E	76-78	<b>516-1020</b>	---
XV500K Virago	1983	<b>516-1024</b>	---
XV535T/TC/U Virago	87-88	<b>516-1026</b>	---
XV535A/AC Virago	1990	<b>516-1026</b>	---
XV535E/EC-L/LC Virago	93-99	<b>516-1026</b>	---
XV535SF/SFC-SJ/SJC Virago	94-97	<b>516-1026</b>	---
XJ550H/J/K Maxim	81-83	<b>516-1024</b>	---
XJ550RH/RJ/RK Seca	81-83	<b>516-1017</b>	---
XT550J/K Dual Sport	82-83	<b>516-1032</b>	---
XZ550RJ/RK Vision	82-83	<b>516-1017</b>	---
FJ600L/LC/N/NC	84-85	<b>516-1024</b>	---
FZ600S/SC/T/TC/U/UC	86-88	<b>516-1024</b>	---
FZR600W/WC/AC	89-90	<b>516-1032</b>	---
FZR600RA/RAC-RL/RLC	90-99	<b>516-1032</b>	---
SRX600S/SC	1986	<b>516-1024</b>	---
XJ600SD/SDC-SJ/SJC Seca II	92-97	<b>516-1032</b>	---
XT600L/LC-EG/EGC Dual Sport	84-95	<b>516-1040</b>	---
YX600S/SC-A/AC Radian	86-90	<b>516-1024</b>	---
YZF600RG/RGC-RV/RVC	95-06	<b>516-1038</b>	---
YZF-R6L/LC-S/SC (43mm forks)	99-04	<b>516-1046</b>	---
YZF-R6SCS (43mm forks)	2004	<b>516-1046</b>	---
YZF-R6T/TC	2005	---	---
YZF-R6V/VVC	2006	---	---
YZF-R6SN/SNC Champions L.E.	2001	<b>516-1046</b>	---
YZF-R6SPV/SPVC 50th Anniversary	2006	---	---
YZF-R6SR/SRC/SS (43mm forks)	03-04	<b>516-1046</b>	---
YZF-R6SV/SVC (43mm forks)	2006	<b>516-1046</b>	---
XJ650G/H/J/K Maxim	80-83	<b>516-1024</b>	---
XJ650LH Midnight Maxim	1981	<b>516-1024</b>	---
XJ650LJ Seca Turbo	1982	<b>516-1024</b>	---
XJ650LK Seca Turbo	1983	<b>516-1029</b>	---
XJ650RJ Seca	1982	<b>516-1024</b>	---
XS1/XS1B/XS2-650	70-72	<b>516-1016</b>	---
TX650/A	73-74	<b>516-1016</b>	---
XS650B/C	75-76	<b>516-1016</b>	---
XS650D/E/F/2F	77-79	<b>516-1019</b>	---
XS650G/H Special II	80-81	<b>516-1019</b>	---
XS650SE/SF/SG/SH Special	78-81	<b>516-1019</b>	---
XS650SJ/SK Heritage Special	82-83	<b>516-1019</b>	---
XVS650AK/AKC-AV/AVC V-Star Classic	98-06	<b>516-1038</b>	---
XVS650ATR/ATRC V-Star Silverado	2003	<b>516-1038</b>	---
XVS650ATS/ATSC V-Star Silverado	2004	<b>516-1038</b>	---
XVS650ATT/ATTC V-Star Silverado	2005	<b>516-1038</b>	---
XVS650ATV/ATVC V-Star Silverado	2006	<b>516-1038</b>	---
XVS650K/KC-S/SC V-Star Custom	98-04	<b>516-1038</b>	---
XVS650T/TC/VVC	05-06	<b>516-1038</b>	---
V-Star Midnight Custom			
FZ700T/TC	1987	<b>516-1034</b>	---
XJ700N/NC/S/SC Maxim	85-86	<b>516-1032</b>	---
XJ700XN/XNC/XS/XSC Maxim X	85-86	<b>516-1032</b>	---
XV700L/LC/N/NC Virago	84-85	<b>516-1032</b>	---
XV700CS/CSC/CT/CTC Virago	86-87	<b>516-1032</b>	---
XV700SS/SSC Virago	1986	<b>516-1032</b>	---
FZ750N/S/SC	85-86	<b>516-1034</b>	---
FZ750U/UC	1988	<b>516-1034</b>	---

# Fork Seals & Dust Seal Kits

## Yamaha Street

Model	Year	Fork Seal Kit	Dust Seal Kit
FZR750RT/RU	87-88	516-1038	————
TX750/A	73-74	516-1019	————
TZ750A Roadracer	1974	516-1019	————
TZ750D Roadracer	1977	516-1019	————
XS750D	1977	516-1020	————
XS7502D/E/SE/F/SF	77-79	516-1026	————
XJ750J/K Maxim	82-83	516-1024	————
XJ750MK Midnight Maxim	82-83	516-1024	————
XJ750RH/RJ/RK Seca	81-83	516-1026	————
XV750H/J/K Virago	81-83	516-1024	————
XV750MK Midnight Virago	1983	516-1024	————
XV750U/UC-G/GC Virago	88-95	516-1032	————
XV750H1/HC1/J1/JC1	96-97	516-1032	————
YZF750RF/RFC	1994	516-1038	————
YZF750RH/RHC-RK/RKC	96-98	516-1038	————
XS850G/H	80-81	516-1026	————
XS850LG/LH Midnight Special	80-81	516-1024	————
XS850SG/SH Special	80-81	516-1024	————
XJ900RK Seca	1983	516-1029	————
XV920J Virago	1982	516-1026	————
XV920K Virago	1983	516-1024	————
XV920MK Midnight Virago	1983	516-1024	————
XV920RH/RJ	81-82	516-1029	————
FZR1000T/TC/U/UC	87-88	516-1038	————
FZR1000W/WC/A/AC	89-90	516-1046	————
FZR1000B/BC/D/DC/E/EC	91-93	516-1038	————
FZR1000F/FC/G/GC	94-95	516-1046	————
FZS1000N/NC-V/V/C FZ1	01-06	516-1044	————
FZS1000SPR/SPRC FZ1	2003	516-1044	————
XV1000L/LC/N/NC Virago	84-85	516-1032	————
YZF1000RK/RKC	1998	516-1038	————
YZF-R1L/LC/M/MC/N/NC	99-01	516-1038	————
YZF-R1P/PC-V/V/C	02-06	516-1046	————
FJ1100L/LC/N/NC	84-85	516-1038	————
XJ1100J Maxim	1982	516-1030	————
XS1100E/F/G/H	78-81	516-1029	————
XS1100LG/LH Midnight Special	80-81	516-1027	————
XS1100SF/SG/SH Special	79-81	516-1027	————
XV1100S/SC-J/JC Virago	86-97	516-1032	————
XV1100SH/SHC/SJ/SJC Virago	96-97	516-1032	————
XVS1100AM/AMC-AS/ASC	00-04	516-1038	————
V-Star 1100 Classic			
XVS1100AWR/AWRC	2003	516-1038	————
V-Star 1100 Classic			
XVS1100AWT/AWTC	2005	516-1038	————
V-Star 1100 Classic			
XVS1100AWV/AWVC	2006	516-1038	————
V-Star 1100 Classic			
XVS1100L/LC-S/SC	99-04	516-1038	————
V-Star 1100 Classic			
XVS1100 V-Star 1100 Custom w/flames	2005	516-1038	————
XVS1100AT V-Star 1100 Silverado	03-06	516-1038	————
FJ1200S/SC/T/TC	86-87	516-1038	————
FJ1200W/WC-D/DC	89-92	516-1038	————
FJ1200AD/ADC/AE/AEC (ABS)	92-93	516-1038	————
VMX12N/NC/S/SC V-Max	85-86	516-1036	————
VMX12U/UC-D/DC	88-92	516-1036	————
VMX12E/EC-V/V/C V-Max	93-06	516-1046	————
XVZ12TK/L/KC2 Venture	83-84	516-1036	————
XVZ12DL/DKC2/DN Venture Royale	84-85	516-1036	————
XVZ12TDK Venture Royale	1983	516-1036	————
XVZ13DS/DSC-DE/DEC Royale	86-93	516-1036	————
XVZ13T/TC/U/UC Venture	87-88	516-1036	————
XVZ13AH/AHC-AK/AKC Royal Star	96-98	516-1044	————
XVZ1300AL/ALC-AN/ANC	99-01	516-1044	————
Royal Star Boulevard			

## Yamaha Street

Model	Year	Fork Seal Kit	Dust Seal Kit
XVZ1300ATH/ATHC-ATM/ATMC	96-00	516-1044	————
Royal Star Tour Classic			
XVZ13LT/LTJC-LTN/LTNC	97-01	516-1044	————
Royal Star Tour Deluxe			
XV1600AL/ALC-AR/ARC Road Star	99-03	516-1044	————
XV1600ALER/ALERC	2003	516-1044	————
Road Star Limited Edition	2003	516-1044	————
XV1600ASN/ASNC/ASP/ASPC	01-02	516-1044	————
Road Star Midnight			
XV1600ASR/ASRC Road Star Midnight	2003	516-1044	————
XV1600ATLRoad Star Silverado	1999	516-1044	————
XV1600ATN/ATNC/ATP/ATPC	01-02	516-1044	————
Road Star Silverado			
XV1600ATR/ATRC Road Star Silverado	2003	516-1044	————
XV1600ATLER/ATLERC	2003	516-1044	————
Road Star Silverado Limited Edition			
XV1700AMS/AMSC/AMT/AMTC	04-05	516-1044	————
Road Star Midnight			
XV1700AS/ASC/AT/ATC Road Star	04-05	516-1044	————
XV1700AV/AVC Road Star	2006	516-1044	————
XV1700ATS/ATSC Road Star Silverado	2004	516-1044	————
XV1700ATT/ATTC Road Star Silverado	2005	516-1044	————
XV1700ATV/ATVC Road Star Silverado	2006	516-1044	————
XV1700ATMS/ATMSC/ATMT/ATMTC	04-05	516-1044	————
Road Star Midnight Silverado			
XV1700ATMV/ATMVC	2006	516-1044	————
Road Star Midnight Silverado			
XV1700AWT/AWTC Road Star	2005	516-1044	————
XV1700AWV/AWVC Road Star	2006	516-1044	————
XV1700PCR/PCRC Road Star Warrior	2003	516-1038	————
XV1700PCRB/PCRCB Road Star Warrior	2003	516-1038	————
XV1700PCS/PCSC Road Star Warrior	2004	516-1038	————
XV1700PCT/PCTC Road Star Midnight	2005	516-1038	————
XV1700PCV/PCVC Road Star Warrior	2006	516-1038	————
XV1700PCT-F/PCTC-F/PCV-F/PCVC-F	05-06	516-1038	————
Road Star Warrior w/flames			
XV1700PCMV/PCMVC	2006	516-1038	————
Road Star Midnight Warrior			

## Yamaha ATV

YT175J/K Tri-Moto	82-83	516-1007	————
YTM200K/L/N/EK/EL/ERN	83-85	516-1007	————
YTM225DXK-DXN/DRN	83-85	516-1007	————
YTZ250N Tri-Z	1985	516-1020	————
YTZ250S Tri-Z	1986	516-1035	————

## Yamaha Dual Sport & Offroad

DT50U/W/A	88-90	516-1006	————
YZ80A/B/C/D/E	74-78	516-1005	————
YZ80F/G/H/J	79-82	516-1007	————
YZ80K-D	83-92	516-1013	————
YZ80E1-N1	93-01	516-1024	————
YZ85P/R/S/T/V/W1/X/Y/Z/A/B/D	02-13	516-1024	————
HT1/HT1B/HT1BM90	70-71	516-1005	————
DT100A/B/C	74-76	516-1006	————
DT100D-K	77-83	516-1005	————
LT2/LT3/LT2M/LT2MX-100	72-73	516-1005	————
MX100A/B	74-75	516-1006	————
MX100F/G/H/J/K	79-83	516-1005	————
RT100A-M	90-00	516-1005	————
YZ100C/D	76-77	516-1016	————
YZ100E/F	78-79	516-1011	————
YZ100G/H	80-81	516-1019	————
YZ100J/K	82-83	516-1025	————
AT1E125 Enduro	1969	516-1006	————

## Yamaha Dual Sport & Offroad

Model	Year	Fork Seal Kit	Dust Seal Kit
AT1B/AT1C/AT2/AT3-125 Enduro	70-73	516-1006	————
AT1M/AT1MB-125	69-70	516-1006	————
AT1MX/AT2M/AT2MX-125	71-73	516-1006	————
DT125A/B/C	74-76	516-1006	————
DT125E	1978	516-1010	————
DT125F/G/H	79-81	516-1011	————
IT125G	1980	516-1011	————
IT125H	1981	516-1019	————
MX125A/B	74-75	516-1006	————
MX125C	1976	516-1016	————
TTR125M/MC/N/P/R/S	00-04	516-1006	————
TTR125ER/ES/ET/EV	03-06	516-1006	————
TTR125LER/LES/LET/LEV	03-06	516-1006	————
TTR125LWM	2000	516-1006	————
TTR125LN/LPC/LR/LS/LT/LV	01-06	516-1006	————
XT125J/K/KC Dual Sport	83-83	516-1011	————
YZ125A/B	74-75	516-1006	————
YZ125C	1976	516-1016	————
YZ125D/E/F/G	77-80	516-1025	————
YZ125H/J/K	81-83	516-1032	————
YZ125L/N	84-85	516-1044	————
YZ125S/T	86-87	516-1047	————
YZ125U	1988	516-1046	————
YZ125W/A	89-90	516-1038	516-2038
YZ125B/D1/E1/F1/G1	91-95	516-1046	516-2046
YZ125H1-R	96-03	516-1050	516-2050
YZ125S1	2004	516-1071	516-2071
YZ125T1/V	05-06	516-1071	————
CT1/B/CT1C-175 Enduro	69-71	516-1006	————
CT2/CT3-175 Enduro	72-73	516-1006	————
DT175A/B/C	74-76	516-1006	————
DT175E	1978	516-1010	————
DT175F/G/H	79-81	516-1011	————
IT175D/E/F/G/H	77-81	516-1025	————
IT175J/K	82-83	516-1032	————
MX175A/B	74-75	516-1006	————
MX175F/G/H	79-81	516-1011	————
TY175B/C Trials	75-76	516-1006	————
BW200N/S/ES/ET/EU	85-88	516-1013	————
IT200L/N/S	84-86	516-1047	————
TW200T/TC-VVC Trailway	87-06	516-1013	————
WR200RD	1992	516-1038	516-2038
XT200J/K/KC Dual Sport	82-83	516-1019	————
TT225S/T	86-87	516-1026	————
TT225L/LC/RM/RMC	00-01	516-1026	————
TT-R225N/NC/P/PC/R/RC	01-03	516-1026	————
TT-R225S/SC	2004	516-1026	————
XT225E/EC-VVC Dual Sport	93-06	516-1026	————
TT-R230T/TC/V	05-06	516-1026	————
DT1/DT1B/DT1C/DT1E-250 Enduro	68-71	516-1016	————
DT1S-250 Enduro	1969	516-1016	————
DT2/DT3-250 Enduro	72-73	516-1016	————
DT250A/B/C/D/E	74-78	516-1016	————
DT250F	1979	516-1025	————
DT1CMX/DT1EMX-250	70-71	516-1016	————
DT2MX-250	1972	516-1016	————
IT250D/E/F/G	77-80	516-1025	————
IT250H/J	81-82	516-1032	————
IT250K	1983	516-1047	————
MX250A/B	73-75	516-1016	————
TT250G/H/J	80-82	516-1025	————
TT250RL/RLC/RM/RMC	99-00	516-1046	516-2046
TT-R250N/NC-VVC	01-06	516-1046	516-2046
TY250A Trials	1974	516-1016	————
TY250C/D Trials	76-77	516-1016	————

## Yamaha Dual Sport & Offroad

Model	Year	Fork Seal Kit	Dust Seal Kit
WR250ZB-ZJ	91-97	516-1046	516-2046
WR250FN/FP/FR/FS	01-04	516-1050	516-2050
WR250FT/FV	05-06	516-1071	————
XT250G/H/J/K/KC Dual Sport	80-83	516-1019	————
XT250L/LC Dual Sport	1984	516-1025	————
YZ250A/B	74-75	516-1016	————
YZ250D/E/F/G	77-80	516-1032	————
YZ250H/J/K/L/N/S/T	81-87	516-1047	————
YZ250U	1988	516-1046	516-2046
YZ250W/A	89-90	516-1038	516-2038
YZ250WRW/WRA	89-90	516-1038	516-2038
YZ250B1/D1/E1/F1/G1	91-95	516-1046	516-2046
YZ250H1/J1/K1/L1/M1	96-00	516-1050	516-2050
YZ250N1/P/R	01-03	516-1050	516-2050
YZ250S1	2004	516-1071	516-2071
YZ250T1/V	05-06	516-1071	————
YZ250FN/FP/FR	01-03	516-1050	516-2050
YZ250FS	2004	516-1071	516-2071
YZ250FT/FV	05-06	516-1071	————
BW350U	1988	516-1013	————
TT350S/T	86-87	516-1041	————
TY350N/S Trials	85-86	516-1025	————
XT350N/NC-M/MC Dual Sport	85-00	516-1025	————
RT1/RT1B-360 Enduro	70-71	516-1016	————
RT2/RT3-360 Enduro	72-73	516-1016	————
RT1M/RT1BMX/RT2MX-360	70-72	516-1016	————
DT360A/B Enduro	74-75	516-1016	————
MX360/A	73-74	516-1016	————
YZ360A/B	74-75	516-1016	————
DT400B/C/D/E	75-78	516-1016	————
IT400C/D/E/F	76-79	516-1025	————
MX400B	1975	516-1016	————
WR400FK/FL/FM	98-00	516-1050	516-2050
YZ400D/E/F	77-79	516-1032	————
YZ400FK/FL	98-99	516-1050	516-2050
IT425G	1980	516-1025	————
WR426FN/FP	01-02	516-1050	516-2050
YZ426FM/FN/FP	00-02	516-1050	516-2050
WR450FR/FS	03-04	516-1050	516-2050
WR450FT/FV	05-06	516-1071	516-2071
YZ450FR	2003	516-1050	516-2050
YZ450FS	2004	516-1071	516-2071
YZ450FT/FV	05-06	516-1071	————
IT465H/J	81-82	516-1032	————
YZ465G	1980	516-1032	————
YZ465H	1981	516-1047	————
IT490K/L	83-84	516-1047	————
YZ490J/K/L/N/S/T	82-87	516-1047	————
YZ490U/W/A	88-90	516-1046	516-2046
SC500/A Scrambler	73-74	516-1016	————
TT500C/D/E/F/G/H	76-81	516-1025	————
XT500C/D/E/F/G/H Dual Sport	76-81	516-1025	————
WR500ZD/ZE	92-93	516-1046	516-2046
XT550J/K Dual Sport	82-83	516-1032	————
TT600K/L/N/S	83-86	516-1047	————
XT600L/LC-EG/EGC Dual Sport	84-95	516-1040	————



# Suspension Accessories



## PC Racing Fork Skins

Forkskins protect the fork tubes from mud and dirt contamination, keeping fork seals clean in all conditions. Increases fork seal life. Included at no charge with each Fork Skins is a set of grip DONUTZ which help prevent nasty thumb blisters.

Description	Order No.
<b>Fork Skins Small Diameter "Short Version"</b> Fits fork tubes with a diameter of 32mm - 43mm. Application: 50cc to 85cc motocross and trail bikes.	<b>945-100</b>
<b>Fork Skins Large Diameter "Short Version"</b> Fits fork tubes with a diameter of 44mm - 50mm. Application: 125cc and larger motocross bikes.	<b>945-101</b>
<b>Fork Skins Small Diameter "Long Version"</b> Fits fork tubes with a diameter of 32mm - 43mm. Application: 50cc to 85cc motocross and trail bikes.	<b>945-103</b>
<b>Fork Skins Large Diameter "Long Version"</b> Fits fork tubes with a diameter of 44mm - 50mm. Application: 125cc and larger motocross bikes	<b>945-104</b>



## PC Racing Fork Support

- Sized to fit most 80cc and up big bore applications
- Stabilizes bike during transportation
- Keeps bike strapped down tight without damaging fork seals
- Bikes won't bounce off tie-down's, preventing damage to motorcycle or vehicle
- Fits all bikes with 11 inches or more of travel
- Polycarbonate injected molded plastic
- Lifetime warranty on Fork Support against breakage

Order No. **945-095**



## Motion Pro Fork Seal Drivers

Manufactured from CAD-II plated carbon steel and features a split design. Each driver weighs approximately 25oz. Sold individually.(split as shown in photo) **Made in U.S.A.**

Size	Order No.
39mm	<b>950-392</b>
41mm	<b>950-393</b>
43mm	<b>950-394</b>
45mm	<b>950-395</b>
46/47mm combo	<b>950-396</b>
48mm <b>New</b>	<b>950-769</b>
49/50mm combo	<b>950-397</b>



## Redline Suspension Fluids

Red Line Suspension Fluids provide very good shear stability which means that they should not degrade with use. They change very little with temperature and will provide lower operating temperatures for the same viscosity when compared to conventional suspension fluids. They are also very low forming and provide good seal lubricity and antiwear properties. They can be blended together in any proportion to achieve an intermediate viscosity. For use in cartridge forks and motorcycle shocks. Sold in 16 oz. bottle.

Description	SAE Weight	Order No.
Like Water Suspension Fluid no	No SAE rating	<b>900-860</b>
Extra Light Suspension Fluid	2.5wt	<b>900-861</b>
Lightweight Suspension Fluid	5wt	<b>900-862</b>
Medium Suspension Fluid	10wt	<b>900-863</b>



## Cartridge Pro Fork Fluid

Meets or exceeds OEM specifications for Showa and Kayaba cartridge / twin chamber forks. Sold in 1 lt. bottle.

Order No. **899-060**



## Seal Mate

Easy way to keep your fork seals clean and debris free. Extract dirt and debris trapped between fork seal and tube. Works on most conventional and up-side-down forks.

Order No. **950-399**



## PJ1 Fork Tuner Oil

For updating and adjusting fork systems.

- An effective and inexpensive method to “tune” conventional fork compression
  - For different rider weights and conditions
- Sold in 1/2 lt. and 1 lt. bottle.

Description	Order No.
2.5W, 1/2 lt. bottle	<b>899-040</b>
5W, 1 lt. bottle	<b>899-043</b>
7.5W, 1 lt. bottle	<b>899-045</b>
10W, 1 lt. bottle	<b>899-047</b>



## Fork Dust Boot (Dust Shield) **NEW**

Replaces Kawasaki OEM 44010-032.

Sold in pair. Available for the the following Kawasaki models.

Order No. **516-010**

### Kawasaki Street

Model	Year
H1D/H1E/H1F-500	73-75
KH500A8	1976
KZ650B1/B2/B2A/B3	77-79
KZ650C1/C2/C3 Custom	77-79
KZ650D1/D1A/D2 SR	78-79
KZ650E1 LTD	1980
KZ650F1	1980
KZ750B1/B2/B3/B4 2-cyl.	77-79
KZ750G1 LTD 2-cylinder	1980
KZ900A4/A5	76-77
KZ900B1 LTD	1976
KZ1000A2/A2A	1978
KZ1000A3/A3A/A4 MKII	79-80
KZ1000B1/B2/B3/B4 LTD	77-80
KZ1000D1 Z1R	1978
KZ1000D3 Z1R	1980
KZ1000G1 LTD Classic	1980

### Kawasaki Offroad

KXT250A1/A2 Tecate 3	84-85
KX250/A/A3	74-76
KX250A4/A5	78-79
KX400/A2	75-76

# Steering Stem Bearing Kits



## Steering Stem Bearing Kits

Quality bearing kits sourced from **Japan** and made to OEM specifications. Kits with an \* (**asterisk**) are an upgrade from stock ball bearing/race to tapered bearing for improved handling and longer life. All other kits are replacements for original tapered bearings.

*Made in Japan.*

### BMW

Upper Bearing Dimension	Lower Bearing Dimension	Mfg.#	Order No.
34 x 51 x 12mm	34 x 51 x 12mm	SSW055*	<b>713-810</b>
28 x 52 x 16.5mm	28 x 52 x 16.5mm	SSW901	<b>713-820</b>

### Honda

22.5 x 41 x 12.5mm	24 x 41 x 12.5mm	SSH200*	<b>713-020</b>
26 x 48.5 x 15.2mm	30 x 50 x 14.4mm	SSH750*	<b>713-030</b>
26 x 47 x 15mm	26 x 47 x 15mm	SSH902	<b>713-042</b>
26 x 47 x 15mm	26 x 47 x 15mm	SSH902R	<b>713-043</b>
26 x 47 x 15mm	30 x 55 x 17mm	SSH903	<b>713-044</b>
26 x 47 x 15mm	30 x 55 x 17mm	SSH903R	<b>713-045</b>
26 x 47 x 15mm	30 x 51 x 15mm	SSH904	<b>713-046</b>
30 x 51 x 15mm	30 x 51 x 15mm	SSH905	<b>713-047</b>
30 x 51 x 15mm	30 x 55 x 17mm	SSH907	<b>713-049</b>

### Kawasaki

30 x 48 x 14mm	30 x 48 x 12mm	SSK100*	<b>713-610</b>
30 x 48 x 14mm	30 x 52 x 17mm	SSK400*	<b>713-630</b>
25 x 47 x 15mm	30 x 55 x 17mm	SSH901	<b>713-040</b>
25 x 47 x 15mm	28 x 52 x 16.5mm	SSK902	<b>713-650</b>
35 x 55 x 14mm	35 x 55 x 14mm	SSK907	<b>713-653</b>

### Suzuki

25 x 48 x 13mm	30 x 48 x 13mm	SSY125*	<b>713-230</b>
25 x 47 x 15mm	30 x 55 x 17mm	SSH901	<b>713-040</b>
25 x 48 x 16mm	27 x 48 x 14mm	SSS250	<b>713-410</b>
25 x 48 x 13mm	30 x 55 x 18mm	SSS902	<b>713-450</b>
30 x 55 x 17mm	30 x 55 x 17mm	SSS903	<b>713-451</b>

### Yamaha

25 x 48 x 16mm	27 x 48 x 14mm	SSS250*	<b>713-410</b>
25 x 43 x 11mm	30 x 48 x 12mm	SSY080*	<b>713-210</b>
25 x 48 x 13mm	30 x 48 x 13mm	SSY125*	<b>713-230</b>
25 x 48 x 15.2mm	30 x 48 x 15mm	SSY500*	<b>713-240</b>
25 x 47 x 15mm	30 x 55 x 17mm	SSH901	<b>713-040</b>
25 x 47 x 15mm	30 x 55 x 17mm	SSH901R	<b>713-041</b>

**Note:** SSH901R contains spacer washer and uses same bearings as SSH901. (SSH901R is not shown in application chart)

## BMW

Model	Year	Mfg. Ref #	Order No.
All BMW models	59-69	SSW055*	<b>713-810</b>
All BMW models except F650	70-	SSW901*	<b>713-820</b>

## Honda Street

MB5-50	1982	SSH200	<b>713-020</b>
NSF50F	1990	SSH200	<b>713-020</b>
CB100/K1/K2 Super Sport 100	70-72	SSH200	<b>713-020</b>
CL100/K1/K2 Scrambler 100	70-72	SSH200	<b>713-020</b>
CL100S/S2/S3 Scrambler 100S	71-73	SSH200	<b>713-020</b>
CB125S/S1/S2	73-75	SSH200	<b>713-020</b>
CB125S	1976	SSH200	<b>713-020</b>
CB125S	78-82	SSH200	<b>713-020</b>
CB125S	84-85	SSH200	<b>713-020</b>
CB125TT	1990	SSH200	<b>713-020</b>
MT125R/RII Roadracer	77-78	SSH200	<b>713-020</b>
CM185T Twinstar	78-79	SSH200	<b>713-020</b>
CM200T Twinstar	80-82	SSH200	<b>713-020</b>
CB250 Nighthawk	91-08	SSH200	<b>713-020</b>
CM250C Custom	82-83	SSH200	<b>713-020</b>
CMX250C/CD Rebel 250	85-87	SSH200	<b>713-020</b>
CMX250C	96-06	SSH200	<b>713-020</b>
CMX250C2	99-00	SSH200	<b>713-020</b>
VTR250 Interceptor	1988	SSH750	<b>713-030</b>
VTR250 Interceptor	89-90	SSH903	<b>713-044</b>
CB350F/F1 Super Sport	73-74	SSH750	<b>713-030</b>
CB350G	1973	SSH750	<b>713-030</b>
CB350/K1-K4 Super Sport	68-72	SSH750	<b>713-030</b>
CL350/K1-K5 Scrambler	68-73	SSH750	<b>713-030</b>
SL350/K1/K2 Motosport	69-73	SSH750	<b>713-030</b>
CB360/G	1974	SSH750	<b>713-030</b>
CB360T	75-76	SSH750	<b>713-030</b>
CJ360T	76-77	SSH750	<b>713-030</b>
CL360/K1 Scrambler	74-75	SSH750	<b>713-030</b>
CB400A Automatic	1978	SSH750	<b>713-030</b>
CB400F Super Sport	75-77	SSH750	<b>713-030</b>
CB400TI/TII Hawk	78-79	SSH750	<b>713-030</b>
CB400T Hawk	80-81	SSH750	<b>713-030</b>
CM400A Automatic	79-81	SSH750	<b>713-030</b>
CM400C Custom	1981	SSH750	<b>713-030</b>
CM400E	80-81	SSH750	<b>713-030</b>
CM400T	79-81	SSH750	<b>713-030</b>
CB450 Super Sport 450	65-68	SSH750	<b>713-030</b>
CB450K1-K7 Super Sport 450	68-74	SSH750	<b>713-030</b>
CB450SC Nighthawk	82-83	SSH750	<b>713-030</b>
CB450SC Nighthawk	85-86	SSH750	<b>713-030</b>
CB450T Hawk	1982	SSH750	<b>713-030</b>
CL450K1-K6 Scrambler	68-74	SSH750	<b>713-030</b>
CM450A Automatic	82-83	SSH750	<b>713-030</b>
CM450C Custom	1982	SSH750	<b>713-030</b>
CM450E	82-83	SSH750	<b>713-030</b>
CMX450C Rebel	86-87	SSH903	<b>713-044</b>
CB500/K1/K2	71-73	SSH750	<b>713-030</b>
CB500T	75-76	SSH750	<b>713-030</b>
CX500	78-79	SSH750	<b>713-030</b>
CX500C Custom	79-82	SSH750	<b>713-030</b>
CX500D	79-81	SSH750	<b>713-030</b>
CX500TC Turbo	1982	SSH903	<b>713-044</b>
FT500 Ascot	82-83	SSH750	<b>713-030</b>
GB500	89-90	SSH750	<b>713-030</b>
GL500 Silverwing	81-82	SSH750	<b>713-030</b>
GL500I Silverwing Interstate	81-82	SSH750	<b>713-030</b>
VF500C Magna	84-85	SSH903R	<b>713-045</b>
VF500F Interceptor	84-86	SSH903R	<b>713-045</b>
VT500C Shadow	83-84	SSH750	<b>713-030</b>
VT500C Shadow	85-86	SSH903R	<b>713-045</b>



## Honda Street

Model	Year	Mfg. Ref #	Order No.
VT500FT Ascot	83-84	SSH750	713-030
CB550F Super Sport	75-77	SSH750	713-030
CB550/K1	74-75	SSH750	713-030
CB550K	76-78	SSH750	713-030
CB550SC Nighthawk	1983	SSH750	713-030
CBR600F Hurricane	87-90	SSH903R	713-045
CBR600F2 Hurricane	91-94	SSH903R	713-045
CBR600F3 Hurricane	95-98	SSH903R	713-045
CBR600SE Hurricane	1998	SSH903R	713-045
CBR600RR	03-06	SSH903R	713-045
CBR600SJR	1996	SSH903R	713-045
CBR600F4 Hurricane	99-01	SSH903R	713-045
VT600C Shadow VLX	88-89	SSH903	713-044
VT600C Shadow VLX	91-97	SSH903	713-044
VT600C Shadow	99-05	SSH903	713-044
VT600CD Shadow VLX Deluxe	93-98	SSH903	713-044
VT600CD Shadow Deluxe	99-06	SSH903	713-044
VT600CD2 Shadow Deluxe	99-00	SSH903	713-044
CB650	79-82	SSH750	713-030
CB650C Custom	80-81	SSH750	713-030
CB650SC Nighthawk	82-85	SSH750	713-030
CX650C	1983	SSH750	713-030
CX650T Turbo	1983	SSH903	713-044
GL650 Silverwing	1983	SSH750	713-030
GL650I Silverwing Interstate	1983	SSH750	713-030
NT650 Hawk GT	88-91	SSH903R	713-045
CB700SC Nighthawk	84-86	SSH903	713-044
VF700C Magna	84-87	SSH903	713-044
VF700F Interceptor	84-85	SSH903R	713-045
VFR700F Interceptor	1986	SSH903R	713-045
VFR700F2 Interceptor	86-87	SSH903R	713-045
VF700S Sabre	84-85	SSH903R	713-045
VT700C Shadow	84-85	SSH750	713-030
VT700C Shadow	86-87	SSH903	713-044
CB750 Nighthawk	91-93	SSH903	713-044
CB750 Nighthawk	95-03	SSH903	713-044
CB750A Automatic	76-78	SSH750	713-030
CB750C Custom	80-82	SSH903	713-044
CB750F Super Sport	75-78	SSH750	713-030
CB750F Super Sport	80-82	SSH903	713-044
CB750K	69-70	SSH750	713-030
CB750K	71-78	SSH750	713-030
CB750K	80-82	SSH903	713-044
CB750SC Nighthawk	82-83	SSH903	713-044
VF750C Magna	82-83	SSH903	713-044
VF750C Magna	1988	SSH903	713-044
VF750C Magna	94-03	SSH903	713-044
VF750CD Magna	95-96	SSH903	713-044
VF750C2 Magna Deluxe	97-03	SSH903	713-044
VF750F Interceptor	83-84	SSH903	713-044
VF750S Sabre	82-83	SSH903	713-044
VFR750F Interceptor	1986	SSH903R	713-045
VFR750F	90-97	SSH903R	713-045
VT750C Shadow	1983	SSH750	713-030
VT750C Shadow Ace 750	98-02	SSH903	713-044
VT750C Shadow Aero	04-06	SSH903	713-044
VT750CA Shadow Aero	04-06	SSH903	713-044
VT750CD Shadow Deluxe	98-02	SSH903	713-044
VT750CD2 Shadow Deluxe	98-02	SSH903	713-044
VT750CDA Shadow Ace 750	02-03	SSH903	713-044
VT750CDB Shadow Ace 750	02-03	SSH903	713-044
VT750CDC Shadow Ace 750	02-03	SSH903	713-044
VT750CDD Shadow Ace 750	02-03	SSH903	713-044
VT750DC Shadow Sprint 750	01-03	SSH903	713-044
VT750DCA Shadow Sprint 750	03-06	SSH903	713-044

## Honda Street

Model	Year	Mfg. Ref #	Order No.
VT750DCB	03-06	SSH903	713-044
PC800 Pacific Coast	89-90	SSH903	713-044
PC800 Pacific Coast	94-98	SSH903	713-044
VFR800 Interceptor	02-06	SSH903R	713-045
VFR800A Interceptor ABS	02-06	SSH903R	713-045
VFR800FI Interceptor	98-01	SSH903R	713-045
VT800C Shadow	1988	SSH903R	713-045
CB900C Custom	80-82	SSH903	713-044
CB900F Super Sport	81-82	SSH903	713-044
CB900F 919	02-06	SSH903R	713-045
CBR900RR	93-99	SSH903R	713-045
CBR929RR	00-01	SSH903R	713-045
CBR954RR	02-03	SSH903R	713-045
CB1000	94-95	SSH903	713-044
CB1000C Custom	1983	SSH903	713-044
CBR1000F Hurricane	87-88	SSH903	713-044
CBR1000F Hurricane	90-91	SSH903B	713-044
CBR1000F Hurricane	93-96	SSH903	713-044
CBX1000	80-82	SSH903	713-044
GL1000 Goldwing	75-76	SSH750	713-030
GL1000L LTD	1976	SSH750	713-030
VF1000F Interceptor	1984	SSH903	713-044
VF1000R	85-86	SSH903	713-044
VTR1000F Super Hawk	98-05	SSH903R	713-045
CB1100F Super Sport	1983	SSH903	713-044
CBR1100XX Blackbird	97-03	SSH903R	713-045
GL1100 Goldwing	80-83	SSH903	713-044
GL1100A Goldwing Aspencade	82-83	SSH903	713-044
GL1100I Goldwing Interstate	80-83	SSH903	713-044
ST1100	91-02	SSH903R	713-045
ST1100A (ABS)	92-02	SSH903R	713-045
VF1100C Magna	83-86	SSH903R	713-045
VF1100S Sabre	84-85	SSH903R	713-045
VT1100C Shadow 1100	85-86	SSH903	713-044
VT1100C Shadow 1100	87-90	SSH903	713-044
VT1100C Shadow 1100	92-96	SSH903	713-044
VT1100C Shadow 1100 Spirit	97-01	SSH903	713-044
VT1100C2 Shadow ACE	95-99	SSH903	713-044
VT1100C2 Shadow Sabre	2000	SSH903	713-044
VT1100C2-2 ACE	1997	SSH903	713-044
VT1100C3 Shadow Aero	98-00	SSH903	713-044
VT1100D2 ACE	1999	SSH903	713-044
VT1100T ACE Tourer	98-00	SSH903	713-044
GL1200 Goldwing	1984	SSH903	713-044
GL1200A Goldwing Aspencade	84-87	SSH903	713-044
GL1200I Goldwing Interstate	84-87	SSH903	713-044
GL1200L Goldwing LTD	1985	SSH903	713-044
GL1200SEi	1986	SSH903	713-044
ST1300	03-06	SSH903R	713-045
ST1300A	03-06	SSH903R	713-045
VTX1300C	03-06	SSH903R	713-045
VTX1300R	05-06	SSH903R	713-045
VTX1300S	03-06	SSH903R	713-045
GL1500 Goldwing	88-90	SSH903	713-044
GL1500A Goldwing Aspencade	91-00	SSH903	713-044
GL1500I Goldwing Interstate	91-96	SSH903	713-044
GL1500SE Goldwing SE	90-00	SSH903	713-044
GL1500C Valkyrie	97-00	SSH903	713-044
GL1500C	2003	SSH903	713-044
GL1500CD	01-03	SSH903	713-044
GL1500CF Valkyrie Interstate	99-01	SSH903	713-044
GL1500CT Valkyrie Tourer	97-00	SSH903	713-044
VTX1800C	02-04	SSH903	713-044
VTX1800R	02-04	SSH903	713-044
VTX1800S	02-04	SSH903	713-044

# Steering Stem Bearing Kits

## Honda ATV

Model	Year	Mfg. Ref #	Order No.
ATC70/K1	73-74	SSH200	713-020
ATC70	78-85	SSH200	713-020
ATC90/K1/K2/K3	70-75	SSH200	713-020
ATC90	76-78	SSH200	713-020
ATC110	79-85	SSH200	713-020
ATC125M	84-87	SSH200	713-020
ATC185	1980	SSH200	713-020
ATC185S	81-83	SSH200	713-020
ATC200	81-83	SSH200	713-020
ATC200E Big Red	82-83	SSH200	713-020
ATC200ES Big Red	1984	SSH200	713-020
ATC200S	84-85	SSH200	713-020
ATC250R	83-86	SSH902	713-042

## Honda Dual Sport & Offroad

CRF50F	04-11	SSH200	713-020
MR50/K1 Elsinore	74-75	SSH200	713-020
XR50R	00-03	SSH200	713-020
Z50AK3/AK4/AK5	72-75	SSH200	713-020
Z50A Mini Trail 50	76-78	SSH200	713-020
Z50R	79-87	SSH200	713-020
Z50RD Special	1986	SSH200	713-020
CR60R	1983	SSH200	713-020
CRF70F	04-07	SSH200	713-020
CL70/K1/K2/K3 Scrambler	69-73	SSH200	713-020
CT70 Trail 70	69-71	SSH200	713-020
CT70H/HK1 Trail 70H	70-73	SSH200	713-020
CT70K1/K2/K3/K4 Trail 70	72-75	SSH200	713-020
CT70 Trail 70	76-82	SSH200	713-020
SL70/K1	71-73	SSH200	713-020
XL70	74-76	SSH200	713-020
XL75	77-79	SSH200	713-020
XR75/K1/K2	73-75	SSH200	713-020
XR75	76-78	SSH200	713-020
CR80R	80-81	SSH200	713-020
CR80R	87-91	SSH902	713-042
CRF80F	04-09	SSH200	713-020
XL80S	80-85	SSH200	713-020
XR80	79-84	SSH200	713-020
XR80R	85-03	SSH200	713-020
CT90 Trail 90	66-68	SSH200	713-020
CT90K1-K6 Trail 90	69-75	SSH200	713-020
CT90 Trail 90	76-79	SSH200	713-020
SL90 Motosport	1969	SSH200	713-020
SL100/K1/K2/K3 Motosport	70-73	SSH200	713-020
CRF100F	04-11	SSH200	713-020
XL100/K1	74-75	SSH200	713-020
XL100	76-78	SSH200	713-020
XL100S	79-85	SSH200	713-020
XR100	81-84	SSH200	713-020
XR100R	85-03	SSH200	713-020
CT110 Trail 110	80-84	SSH200	713-020
CT110 Trail 110	1986	SSH200	713-020
CR125M/M1 Elsinore	74-78	SSH200	713-020
CR125R	82-83	SSH902	713-042
CR125R	84-89	SSH902R	713-043
CR125R	90-92	SSH904	713-046
CR125R	93-94	SSH905	713-047
CR125R	95-97	SSH907	713-049
CR125R	98-07	SSH905	713-047
CT125 Trail 125	1977	SSH200	713-020
MT125K Elsinore	74-76	SSH200	713-020
NX125	88-90	SSH902	713-042
SL125/K1/K2 Motosport	71-73	SSH200	713-020
TL125/K1/K2/S Trials	73-76	SSH200	713-020
XL125/K1	74-75	SSH200	713-020

## Honda Dual Sport & Offroad

Model	Year	Mfg. Ref #	Order No.
XL125S	76-82	SSH200	713-020
XL125S	84-85	SSH200	713-020
MR175K Elsinore	75-77	SSH200	713-020
XL185S	79-83	SSH200*	713-020
XR185	1979	SSH200*	713-020
XL200R Dual Sport	83-84	SSH902	713-042
XR200 (2 shock)	80-84	SSH200*	713-020
XR200R Prolink	81-83	SSH902	713-042
XR200R Prolink	84-87	SSH902	713-042
XR200R	1988	SSH902R	713-043
XR200R	90-91	SSH902R	713-043
XR200R	93-03	SSH902R	713-043
CR250R	81-83	SSH902	713-042
CR250R	84-89	SSH902R	713-043
CR250R	90-91	SSH904	713-046
CR250R	92-94	SSH905	713-047
CR250R	95-96	SSH907	713-049
CR250R	97-05	SSH905	713-047
NX250	88-90	SSH902R	713-043
XL250R	82-87	SSH902R	713-043
XR250L	91-96	SSH902R	713-043
XR250R	81-82	SSH902	713-042
XR250R	84-87	SSH902R	713-043
XR250R	88-91	SSH902	713-042
XR250R	92-03	SSH902R	713-043
XL350R	84-85	SSH902	713-042
XR350R	83-85	SSH902	713-042
XR400R	97-04	SSH902	713-042
CR450R	1981	SSH902	713-042
CRF450R	02-08	SSH905	713-047
CRF450X	05-09	SSH905	713-047
CR480R	82-83	SSH902	713-042
CR500R	84-89	SSH902R	713-043
CR500R	90-01	SSH904	713-046
XL500R	1982	SSH902	713-042
XR500R	81-84	SSH902	713-042
XL600R	83-87	SSH902	713-042
XL600V Transalp	89-90	SSH902	713-042
XR600R	85-87	SSH902	713-042
XR600R	88-00	SSH902R	713-043
NX650	88-89	SSH902R	713-043
XR650L	93-07	SSH902R	713-043
XR650R	01-07	SSH902R	713-043

## Kawasaki Street

EL250B2/B3 Eliminator	88-89	SSK400	713-630
EL250E1/E2/E3 250HS Eliminator	91-93	SSK400	713-630
EX250E1/E2 Ninja 250R	86-87	SSK400	713-630
EX250F6-F19 Ninja 250R	92-05	SSK400	713-630
EX250F6F Ninja 250R	2006	SSK400	713-630
S1A/B/C-250 (2-stroke triple)	73-75	SSK100	713-610
KH250A5 (2-stroke triple)	1976	SSK100	713-610
EX305B1 GPz	1983	SSK100	713-610
KZ305A1/A2 CSR	81-82	SSK100	713-610
KZ305B1 CSR Belt	1982	SSK100	713-610
KZ305B2/B3 LTD Belt	87-88	SSK100	713-610
S2/S2A 350 (2-stroke triple)	72-73	SSK100	713-610
S3/S3A-400 (2-stroke triple)	74-75	SSK100	713-610
KH400A3/A4/A5 (2-stroke triple)	76-78	SSK100	713-610
KZ400A1/A2 Deluxe	77-78	SSK100	713-610
KZ400B1/B2	78-79	SSK100	713-610
KZ400C1	1978	SSK100	713-610
KZ400/D/D3/D4	74-77	SSK100	713-610
KZ400H1 LTD	1979	SSK100	713-610
KZ400S/S2/S3 Special	75-77	SSK100	713-610
KZ440A1/A2/A3/A4 LTD	80-83	SSK100	713-610

## Kawasaki Street

Model	Year	Mfg. Ref #	Order No.
KZ440B1/B2	80-81	SSK100	713-610
KZ440D1-D5 LTD Belt	80-83	SSK100	713-610
KZ440G1 Belt	1982	SSK100	713-610
EN450A1-A6 LTD 454	85-90	SSK902	713-650
H1C/D/E/F-500 (2-stroke triple)	72-75	SSK100	713-610
KH500A8 2-stroke triple	1976	SSK100	713-610
EN500A1-A6 Vulcan 500	90-96	SSK902	713-650
EN500C1-C10 Vulcan 500 LTD	96-05	SSK902	713-650
EN500C7F Vulcan 500 LTD	06-07	SSK902	713-650
EX500A1-A7	87-93	SSK400	713-630
EX500D1/D2/D3 Ninja 500	94-96	SSK400	713-630
EX500D4-D12 Ninja 500R	97-05	SSK400	713-630
EX500D6F-D9F Ninja 500R	06-09	SSK400	713-630
KZ550A1/A2/A3/A4	80-83	SSK400	713-630
KZ550C1/C2/C3/C4 LTD	80-83	SSK400	713-630
KZ550D1 GPz	1981	SSK400	713-630
KZ550H1/H2 GPz	82-83	SSK902	713-650
KZ550F1/F2 Spectre & LTD	83-84	SSK902	713-650
KZ550M1 LTD	1983	SSK902	713-650
ZR550B1/B2/B3/B4 Zephyr	90-93	SSK902	713-650
ZX550A1/A2 GPz	84-85	SSK902	713-650
ZX600A1/A2/A3 Ninja 600R	85-87	SSK902	713-650
ZX600B1 Ninja 600RX	1987	SSK902	713-650
ZX600C1-C10 Ninja 600R	88-97	SSK902	713-650
ZX600D1/D2/D3/D4 Ninja ZX-6	90-93	SSK902	713-650
ZX600E1-E10 Ninja ZX-6	93-02	SSK902	713-650
ZX600F1/F2/F3 Ninja ZX-6R	95-97	SSK902	713-650
EJ650A2/A3 W650	00-01	SSK902	713-650
KZ650B1/B2/B2A/B3	77-79	SSK400	713-630
KZ650C1/C2/C3 Custom	77-79	SSK400	713-630
KZ650D1/D1A/D2 SR	78-79	SSK400	713-630
KZ650E1/F1	1980	SSK400	713-630
KZ650H1/H2/H3 CSR	81-83	SSK400	713-630
KZ700A1	1984	SSK902	713-650
ZN700A1/A2 LTD	84-85	SSK902	713-650
H2/A/B/C-750 triple	72-75	SSK100	713-610
KZ750B1/B2 (2-cylinder)	76-77	SSK400	713-630
KZ750B3/B4 (2-cylinder)	78-79	SSK400	713-630
KZ750E1/E2/E3	80-82	SSK400	713-630
KZ750F1 LTD	1983	SSK902	713-650
KZ750G1 LTD (2-cylinder)	1980	SSK400	713-630
KZ750H1/H2/H3/H4 LTD	80-83	SSK400	713-630
KZ750K1/K2 LTD (2-cylinder)	83-84	SSK400	713-630
KZ750L3	1983	SSK902	713-650
KZ750M1 CSR (2-cylinder)	1982	SSK400	713-630
KZ750N1/N2 Spectre	82-83	SSK902	713-650
KZ750R1 GPz	1982	SSK902	713-650
ZR750C1/C2/C3 Zephyr	91-93	SSK902	713-650
ZR750F2 ZR-7	2000	SSK902	713-650
ZX750A1/A2/A3 GPz	83-85	SSK902	713-650
ZX750E1/E2 GPz Turbo	84-85	SSK902	713-650
ZX750F1/F2/F3/F4 Ninja 750R	87-90	SSK902	713-650
ZX750H1/H2 Ninja ZX-7	89-90	SSK902	713-650
ZX750J1/J2 Ninja ZX-7	91-92	SSK907	713-653
ZX750K1/K2 Ninja ZX-7R	91-92	SSK907	713-653
ZX750L1/L2/L3 Ninja ZX-7	93-95	SSK907	713-653
ZX750M1/M2 Ninja ZX-7R	93-94	SSK907	713-653
ZX750N1/N2 Ninja ZX-7RR	96-97	SSK907	713-653
ZX750P1-P6 ZX-7R	96-01	SSK907	713-653
VN800A1-A7 Vulcan 800	95-01	SSK902	713-650
VN800B1-B6 Vulcan 800 Classic	96-01	SSK902	713-650
VN800C1/C2/E1 Vulcan 800 Drifter	99-01	SSK902	713-650
Z1/A/B-900	73-75	SSK400	713-630
KZ900A4/A5	76-77	SSK400	713-630
KZ900B1 LTD	1976	SSK400	713-630
ZL900A1/A2 Eliminator	85-86	SSK902	713-650

## Kawasaki Street

Model	Year	Mfg. Ref #	Order No.
ZX900A1/A2/A3 Ninja 900R	84-86	SSK902	713-650
ZX900B1/B2/B3/B4 Ninja ZX-9R	94-97	SSK907	713-653
ZX900C1/C2 Ninja ZX-9R	98-99	SSK907	713-653
KZ1000A1/A2/A2A	77-78	SSK400	713-630
KZ1000A3/A3A/A4 MKII	79-80	SSK400	713-630
KZ1000B1/B2/B3/B4 LTD	77-80	SSK400	713-630
KZ1000C1/C1A/C2/C3/C4 Police	78-81	SSK400	713-630
KZ1000D1 Z1R	1978	SSK400	713-630
KZ1000D3 Z1R	1980	SSK400	713-630
KZ1000G1 LTD Classic	1980	SSK400	713-630
KZ1000J1/J2/J3	81-83	SSK902	713-650
KZ1000K1/K2 LTD	81-82	SSK902	713-650
KZ1000M1/M2 CSR	81-82	SSK902	713-650
KZ1000P1-P21 Police	82-02	SSK902	713-650
KZ1000R1/R2 Replica	82-83	SSK902	713-650
ZG1000A1-A20 Concours	86-05	SSK902	713-650
ZL1000A1 Eliminator	1987	SSK902	713-650
ZX1000A1/A2 Ninja 1000R	86-87	SSK902	713-650
ZX1000B1/B2/B3 Ninja ZX-10	88-90	SSK902	713-650
KZ1100A1/A2/A3 Shaft	81-83	SSK902	713-650
KZ1100B1/B2 GPz	81-82	SSK902	713-650
KZ1100D1/D2 Spectre	82-83	SSK902	713-650
KZ1100L1 LTD	1983	SSK902	713-650
ZN1100B1/B2 LTD Shaft	84-85	SSK902	713-650
ZR1100A1-A4	92-95	SSK902	713-650
ZR1100C3/C4 ZRX1100	99-00	SSK902	713-650
ZX1100A1/A2 GPz	83-84	SSK902	713-650
ZX1100D1-D9 Ninja ZX-11	93-01	SSK907	713-653
ZG1200A1 Voyager XII	1986	SSH901	713-040
ZG1200B1-B17 Voyager XII	87-03	SSH901	713-040
VN1500A1-A9 Vulcan 88	87-95	SSK902	713-650
VN1500A10-A12 Vulcan 1500	96-98	SSK902	713-650
VN1500B1/B2/B3/B4 Vulcan 88 SE	87-90	SSK902	713-650
VN1500C3/C4 Vulcan 1500L	96-97	SSK902	713-650
VN1500D1/D2 Vulcan Classic	96-97	SSK902	713-650
VN1500E1-E4 Vulcan Classic	98-01	SSK902	713-650
VN1500G1/G1A/G2A/G3 Nomad	99-01	SSK907	713-653
VN1500J1/J2/R1 Vulcan Drifter	99-01	SSK907	713-653
VN1500L1/L2 Vulcan Nomad F.I.	00-01	SSK907	713-653
VN1500N1/N2 Vulcan Classic F.I.	00-01	SSK907	713-653

## Kawasaki ATV

KXT250A1/A2/B1/B2 Tecate 3	84-87	SSH901	713-040
----------------------------	-------	--------	---------

## Kawasaki Dual Sport & Offroad

KX125B1/B2/C1/D1/E1/E2	82-87	SSH901	713-040
KX125F1/G1/H1/H2	88-91	SSH901	713-040
KDX200A1/A2/A3/C1/C2/C3	83-88	SSH901	713-040
KDX200E1/E2/E3/E4/E5/E6	89-94	SSH901	713-040
KDX200H1-H10	95-04	SSH901	713-040
KDX220A4-A11	97-04	SSH901	713-040
KDX250A1/B1/B2/B3/B4	80-84	SSH901	713-040
KL250D2-D22 KLR250	85-05	SSK902	713-650
KL250G4/G5/G6/G7 Super Sherpa	00-03	SSK902	713-650
KLX250D2/D3/D4	94-96	SSH901	713-040
KX250B1/C1/C2	82-84	SSH901	713-040
KX250D1/D2/E1/F1/G1/H1/H2	85-91	SSH901	713-040
KLX300A2-A10 KLX300R	97-05	SSK902	713-650
KLX300A6F	2006	SSK902	713-650
KDX420B1	1981	SSH901	713-040
KX420A1/A2	80-81	SSH901	713-040
KDX450A1	1982	SSH901	713-040
KX500A1/A2/B1/B2/C1/D1	83-88	SSH901	713-040
KX500E1-E16	89-04	SSH901	713-040
KL600A1/B1/B2 KLR600	84-86	SSK902	713-650
KL650A1-A19 KLR650	87-05	SSK902	713-650

# Steering Stem Bearing Kits

## Kawasaki Dual Sport & Offroad

Model	Year	Mfg. Ref #	Order No.
KL650A6F KLR650	2006	SSK902	<b>713-650</b>
KL650B2 Tengai KLR650	1990	SSK902	<b>713-650</b>
KLX650A1/A2/A3 Offroad	93-95	SSH901	<b>713-040</b>
KLX650C1/C2/C3/C4 Dual Sport	93-96	SSH901	<b>713-040</b>
KLX650D1 Offroad	1996	SSH901	<b>713-040</b>

## Suzuki Street

GN250Z/D/F	82-85	SSH901	<b>713-040</b>
GN250J	1988	SSH901	<b>713-040</b>
GS250TT/TX	80-81	SSS250	<b>713-410</b>
GT250A/B Hustler	76-77	SSS250	<b>713-410</b>
GS300LZ/LD	82-83	SSS250	<b>713-410</b>
GS300LF	1985	SSS250	<b>713-410</b>
GT380K/L/M/A/B Sebring	73-77	SSS250	<b>713-410</b>
GN400T/XT/XX/TX/TZ	80-82	SSH901	<b>713-040</b>
GS400B/XB/C/XC	77-78	SSS250	<b>713-410</b>
GSF400M/N/P Bandit	91-93	SSH901	<b>713-040</b>
GS425N/EN/LN	1979	SSS250	<b>713-410</b>
GS450ET/EX/EZ/ED	80-83	SSH901	<b>713-040</b>
GS450GAZ/GAD Automatic	82-83	SSH901	<b>713-040</b>
GS450GAF Automatic	1985	SSH901	<b>713-040</b>
GS450LT/LX/LZ/LD	80-83	SSH901	<b>713-040</b>
GS450LF/LG/LH/LJ	85-88	SSH901	<b>713-040</b>
GS450ST/SX	80-81	SSH901	<b>713-040</b>
GS450TX/TZ	81-82	SSH901	<b>713-040</b>
GS450TXZ/TXD	82-83	SSH901	<b>713-040</b>
GS500EK-K2	89-02	SSH901	<b>713-040</b>
GT500A/B Titan	76-77	SSS250	<b>713-410</b>
RE-5M/A Rotary	75-76	SSS250	<b>713-410</b>
GS550B/C/EC/N/EN	77-79	SSS250	<b>713-410</b>
GS550ET	1980	SSH901	<b>713-040</b>
GS550ED/ESD	1983	SSH901	<b>713-040</b>
GS550ES3/ESE/EF/ESF/ESG	83-86	SSH901	<b>713-040</b>
GS550LN	1979	SSS250	<b>713-410</b>
GS550LT/LX/LZ/LD	80-83	SSH901	<b>713-040</b>
GS550LF/LG	85-86	SSH901	<b>713-040</b>
GS550MZ Katana	1982	SSH901	<b>713-040</b>
GS550TX	1981	SSH901	<b>713-040</b>
GT550J/K/L/M/A/B Indy	72-77	SSS250	<b>713-410</b>
GSF600ST-SK3 Bandit	96-03	SSH901	<b>713-040</b>
GSX600FJ-K6 Katana	88-06	SSH901	<b>713-040</b>
GSX-R600WN/WP	92-93	SSH901	<b>713-040</b>
GSX-R600V-K5	97-05	SSS903	<b>713-451</b>
RF600RR/RS/RT	94-96	SSH901	<b>713-040</b>
GR650D/XD Tempter	1983	SSH901	<b>713-040</b>
GS650EX/EZ	81-82	SSH901	<b>713-040</b>
GS650GX/GZ/GD	81-83	SSH901	<b>713-040</b>
GS650GLX/GLZ/GLD	81-83	SSH901	<b>713-040</b>
GS650MDKatana	1983	SSH901	<b>713-040</b>
LS650PS-PK4 Savage	95-04	SSH901	<b>713-040</b>
SV650X/Y/K1/K2/K3/K4/K5 /K6/K7	99-07	SSH901	<b>713-040</b>
SV650SX-SK7	99-07	SSH901	<b>713-040</b>
XN85D Turbo	1983	SSH901	<b>713-040</b>
GS700EF/ESF	1985	SSH901	<b>713-040</b>
GV700GLF/GLF2 Madura	1985	SSH901	<b>713-040</b>
VS700G Intruder	86-87	SSH901	<b>713-040</b>
GS750B/C/EC/N/EN	77-79	SSS250	<b>713-410</b>
GS750ET/EX/EZ	80-82	SSH901	<b>713-040</b>
GS750ED/ESD	1983	SSH901	<b>713-040</b>
GS750LN	1979	SSS250	<b>713-410</b>
GS750LT/LX	80-81	SSH901	<b>713-040</b>
GS750TZ/TD	82-83	SSH901	<b>713-040</b>
GS750SD Katana	1983	SSH901	<b>713-040</b>

## Suzuki Street

Model	Year	Mfg. Ref #	Order No.
GSX750FK-FK7 Katana	89-07	SSH901	<b>713-040</b>
GSX-R750RG	1986	SSH901	<b>713-040</b>
GSX-R750G/H/J/K/L/M/N	86-92	SSH901	<b>713-040</b>
GSX-R750WP/WR/WS	93-95	SSH901	<b>713-040</b>
GSX-R750T/V/W/X/Y	96-00	SSS903	<b>713-451</b>
GSX-R750K1/K2/K3/K4/K5	01-05	SSS903	<b>713-451</b>
GT750J/K/L/M/A/B Lemans	72-77	SSS250	<b>713-410</b>
VS750GLPJ-GLPM Intruder	88-91	SSH901	<b>713-040</b>
VS800GLPN-GLPK4 Intruder	92-04	SSH901	<b>713-040</b>
VX800L/M/N/P	90-93	SSH901	<b>713-040</b>
VZ800V-K4 Marauder	97-04	SSH901	<b>713-040</b>
GS850GN/GT/GX/GZ/GD	79-83	SSH901	<b>713-040</b>
GS850GLT/GLX/GLZ/GLD	80-83	SSH901	<b>713-040</b>
RF900RR/RS/RT/RV	94-97	SSH901	<b>713-040</b>
DL1000K2-K5 V-Storm	02-05	SSS903R	_____
GS1000C/EC/N/EN	78-79	SSH901	<b>713-040</b>
GS1000ET	1980	SSH901	<b>713-040</b>
GS1000GT/GLT/GX/GLX	80-81	SSH901	<b>713-040</b>
GS1000LN	1979	SSH901	<b>713-040</b>
GS1000SN/ST	79-80	SSH901	<b>713-040</b>
GS1000SZ Katana	1982	SSH901	<b>713-040</b>
GSX-R1000K1/K2/K3/K4/K5	01-05	SSS903	<b>713-451</b>
TL1000SV-SK1	97-01	SSS903	<b>713-451</b>
TL1000RW-RK3	98-03	SSS903R	_____
GS1100ET/EX/EZ/ED/ESD	80-83	SSH901	<b>713-040</b>
GS1100GZ/GLZ/GD/GLD	82-83	SSH901	<b>713-040</b>
GS1100LT	1980	SSH901	<b>713-040</b>
GS1100SD Katana	1983	SSH901	<b>713-040</b>
GSX1100FJ-FP Katana	88-93	SSH901	<b>713-040</b>
GSX1100GM/GN/GP Shaft	91-93	SSH901	<b>713-040</b>
GSX-R1100G/H/J/K/L/M/N	86-92	SSH901	<b>713-040</b>
GSX-R1100WP-WW	93-98	SSH901	<b>713-040</b>
GS1150ES3/ESE/EF/ESF/EG	83-86	SSH901	<b>713-040</b>
GSF1200SV-SK6 Bandit	97-06	SSH901	<b>713-040</b>
GSF1200SAV Bandit	1997	SSH901	<b>713-040</b>
GV1200GLF/GLF2/GLG Madura	85-86	SSH901	<b>713-040</b>
GV1400GCG/GCH Cavalcade LX	86-87	SSH901	<b>713-040</b>
GV1400GDG-GDJ Cavalcade LX	86-88	SSH901	<b>713-040</b>
GV1400GTG/GTH Cavalcade	86-87	SSH901	<b>713-040</b>
VS1400GLPH-GLPK2 Intruder	87-02	SSH901	<b>713-040</b>
VL1500W/X/Y/K1/K2/K3 Intruder	98-03	SSH901	<b>713-040</b>

## Suzuki Dual Sport & Offroad

RM100N/T/X	79-81	SSY125	<b>713-230</b>
DR125SER/SES/SET Dual Sport	94-96	SSH901	<b>713-040</b>
RM125A/B/C	75-78	SSS250	<b>713-410</b>
RM125N/T	79-80	SSY125	<b>713-230</b>
RM125J	1988	SSH901	<b>713-040</b>
PE175C/N	78-79	SSS250	<b>713-410</b>
PE175T/X	80-81	SSH901	<b>713-040</b>
PE175Z/D/E	82-84	SSH901	<b>713-040</b>
RS175T/X/Z	80-82	SSH901	<b>713-040</b>
DR200SET-SEK6 Dual Sport	96-06	SSH901	<b>713-040</b>
DR250L/M/N/P Offroad	90-93	SSH901	<b>713-040</b>
DR250SL-SES Dual Sport	90-95	SSH901	<b>713-040</b>
PE250C/N	78-79	SSS250	<b>713-410</b>
PE250T/X	80-81	SSH901	<b>713-040</b>
RM250A/B/C/C2	76-78	SSS250	<b>713-410</b>
RM250N/T	79-80	SSY125	<b>713-230</b>
RM250J	1988	SSH901	<b>713-040</b>
RS250T/X	80-81	SSH901	<b>713-040</b>
SP250Z/D	82-83	SSS902	<b>713-450</b>
SP250F	1985	SSS902	<b>713-450</b>

## Suzuki Dual Sport & Offroad

Model	Year	Mfg. Ref #	Order No.
TM250J/K/L/M	72-75	SSS250	713-410
TS250R/J/K/L/M/A/B/C/N	71-79	SSS250	713-410
DR350L-X Offroad	90-99	SSH901	713-040
DR350SL-SEX Dual Sport	90-99	SSH901	713-040
RM370A/B	76-77	SSS250	713-410
SP370C/N Dual Sport	78-79	SSS250	713-410
DR400T	1980	SSH901	713-040
PE400T/X	80-81	SSH901	713-040
RM400C	1978	SSS250	713-410
RM400N/T	79-80	SSY125	713-230
SP400T Dual Sport	1980	SSS250	713-410
TM400	73-75	SSS250	713-410
TS400	73-77	SSS250	713-410
DR500X/Z/D	81-83	SSH901	713-040
RM500D/E	83-84	SSS902	713-450
SP500X/Z/D Dual Sport	81-83	SSH901	713-040
DR650SN/SP/SER/SES Dual Sport	92-95	SSH901	713-040

## Yamaha Street

RX50K	1983	SSY080	713-210
RX50MK Midnight Special	1983	SSY080	713-210
YSR50T/U/W/A/B/D	87-92	SSY080	713-210
RD60/A/B	73-75	SSY080	713-210
L5T/L5TA 100	69-70	SSY125	713-230
RD125B/C	75-76	SSY125	713-230
TA125		SSY125	713-230
TD2/TD2B/TR2/TR2B-125	70-71	SSY125	713-230
TZ125G	1980	SSY125	713-230
SR185H/J Exciter	81-82	SSY080	713-210
RD200A/B/C	74-76	SSY125	713-230
RD250A/B	73-75	SSY125	713-230
SR250G/H/J Exciter	80-82	SSY125	713-230
SR250TH Exciter II	1981	SSY125	713-230
SRX250T/TC	1987	SSY125	713-230
TD3/TR3 250 (Race)	1972	SSY125	713-230
TZ250 (Race)	1973	SSY125	713-230
TZ250C/D/E (Race)	76-78	SSY125	713-230
TZ250F/G/H/J (Race)	79-82	SSH901	713-040
XV250U/UC/W/WC Route 66	88-89	SSY125	713-230
XV250A/AC Route 66	1990	SSY125	713-230
XV250G/GC-L/LC Route 66	95-99	SSY125	713-230
XV250M/MC-T/TC Virago 250	00-05	SSY125	713-230
R5/B/C 350	70-72	SSY125	713-230
RD350A/B	73-75	SSY125	713-230
RZ350L/N/NC/NCII	84-85	SSY125	713-230
TZ350C/D/E	74-78	SSY125	713-230
XS360C/D/2D	76-77	SSY125	713-230
FZR400U/SUC/W/SWC/A/SAC	88-90	SSH901	713-040
RD400C/D/E/F	76-79	SSY125	713-230
XS400D/E/F	77-79	SSY125	713-230
XS400E/2F	78-79	SSY125	713-230
XS400G/H Special II	80-81	SSY125	713-230
XS400J/K Maxim	82-83	SSY125	713-230
XS400RJ/RK Seca	82-83	SSY125	713-230
XS400SG/SH Special	80-81	SSY125	713-230
XS400SJ Heritage Special	1982	SSY125	713-230
SR500E/F/G/H	78-81	SSY080	713-210
TX500A	73-74	SSY500	713-240
XS500B/C/D/E	75-78	SSY500	713-240
XT500C/D/E/F/G/H Dual Sport	76-81	SSY080	713-210
XV500K Virago	1983	SSY125	713-230
XV535T/TC/U Virago	87-88	SSY125	713-230
XV535A/AC Virago	1990	SSY125	713-230

## Yamaha Street

Model	Year	Mfg. Ref #	Order No.
XV535E/EC-L/LC Virago	93-99	SSY125	713-230
XV535SF/SFC-SJ/SJC Virago	94-97	SSY125	713-230
XJ550H/J/K Maxim	81-83	SSY125	713-230
XJ550RH/RJ/RK Seca	81-83	SSY125	713-230
XZ550RJ/RK Vision	82-83	SSY500	713-240
FJ600L/LC/N/NC	84-85	SSY125	713-230
FZ600S/SC/T/TC/U/UC	86-88	SSY500	713-240
FZR600W/WC/AC	89-90	SSH901	713-040
FZR600RA/RAC-RL/RLC	90-99	SSH901	713-040
XJ600SD/SDC-SK/SKC Seca II	92-98	SSH901	713-040
SRX600S/SC	1986	SSY500	713-240
YX600S/SC-A/AC Radian	86-90	SSY125	713-230
YZF600RG/RGC-RV/RVC	95-06	SSH901	713-040
YZF-R6L/LC-T/TC	99-05	SSS903R	---
YZF-R6SN/SNC Champions LTD. ED	2001	SSS903R	---
XS1/XS1B/XS2 650	70-72	SSY500	713-240
TX650/A	73-74	SSY500	713-240
XS650B/C/D/E/F/2F	75-79	SSY500	713-240
XS650G/H Special II	80-81	SSY500	713-240
XS650SE/SF/SG/SH	78-81	SSY500	713-240
XS650SJ/SK Heritage Special	82-83	SSY500	713-240
XJ650G/H/J/K Maxim	80-83	SSY500	713-240
XJ650LH Midnight Maxim	1981	SSY500	713-240
XJ650LJ/LK Seca Turbo	82-83	SSY500	713-240
XJ650RJ Seca	1982	SSY500	713-240
XVS650L/LC-T/TC V-Star	99-05	SSH901	713-040
XVS650AK/AKC-ATC V-Star Classic	98-05	SSH901	713-040
XVS650ATR/ATRC/ATS Silverado	03-04	SSH901	713-040
XVS650ATT/ATTC V-Star Silverado	2005	SSH901	713-040
XVS650K/KC-T/TC V-Star Custom	98-05	SSH901	713-040
FZ700T/TC	1987	SSH901	713-040
FZX700S/SC/T/TC Fazer	86-87	SSH901	713-040
XJ700N/NC/S/SC Maxim	85-86	SSH901	713-040
XJ700XN/XNC/XS/XSC Maxim X	85-86	SSH901	713-040
XV700L/LC/N/NC Virago	84-85	SSH901	713-040
XV700CS/CSC/CT/CTC Virago	86-87	SSH901	713-040
XV700SS/SSC Virago	1986	SSH901	713-040
FZ750N/S/SC	85-86	SSH901	713-040
FZ750U/UC	1988	SSH901	713-040
FZR750RT/RU	87-88	SSH901	713-040
TX750/A	73-74	SSY500	713-240
XS750D/2D/E/F	77-79	SSH901	713-040
XS750SE/SF Special	78-79	SSH901	713-040
XJ750J/K Maxim	82-83	SSY500	713-240
XJ750MK Midnight Maxim	1983	SSY500	713-240
XJ750RH/RJ/RK Seca	81-83	SSY500	713-240
XV750H/J/K Virago	81-83	SSY500	713-240
XV750MK Midnight Virago	1983	SSY500	713-240
XV750U/UC-G/GC Virago	88-95	SSH901	713-040
XV750H1/HC1/J1/J1C Virago	96-97	SSH901	713-040
YZF750RF/RFC	1994	SSH901	713-040
YZF750RH/RHC/RK/RKC	96-98	SSH901	713-040
TDM850D/DC/E/EC	92-93	SSH901	713-040
XS850G/H	80-81	SSH901	713-040
XS850LG/LH Midnight Special	80-81	SSH901	713-040
XS850SG/SH Special	80-81	SSH901	713-040
XJ900RK Seca	1983	SSH901	713-040
XV920J/K/MK Virago	82-83	SSY500	713-240
XV920RH/RJ	81-82	SSY500	713-240
FZR1000T/TC-G/GC	87-95	SSH901	713-040
FZS1000N/NC-T/TC FZ1	01-05	SSH901	713-040
XV1000L/LC/N/NC Virago	84-85	SSH901	713-040
YZF1000R/RJC	1997	SSH901	713-040

# Steering Stem Bearing Kits

## Yamaha Street

Model	Year	Mfg. Ref #	Order No.
YZF1000RK/RKC	1998	SSS903R	_____
YZF-R1L/LC-T/TC	99-05	SSS903R	_____
YZF-R1SN/SNC Champions LTD.ED.	2001	SSS903R	_____
FJ1100L/LC/N/NC	84-85	SSH901	<b>713-040</b>
XJ1100J Maxim	1982	SSH901	<b>713-040</b>
XS1100E/F/G/H	78-81	SSH901	<b>713-040</b>
XS1100L/LH Midnight Special	80-81	SSH901	<b>713-040</b>
XS1100SF/SG/SH Special	79-81	SSH901	<b>713-040</b>
XV1100S/SC-L/LC Virago	86-99	SSH901	<b>713-040</b>
XV1100SH/SHC-SK/SKC Virago	96-98	SSH901	<b>713-040</b>
XVS1100A V-Star 1100 Classic	00-04	SSH901	<b>713-040</b>
XVS1100A V-Star 1100 Silverado	03-05	SSH901	<b>713-040</b>
XVS1100AT V-Star 1100 Silverado	2005	SSH901	<b>713-040</b>
XVS1100AW V-Star 1100 Classic	03-05	SSH901	<b>713-040</b>
XVS1100L/LC-S/SC V-Star Custom	99-04	SSH901	<b>713-040</b>
FJ1200S/SC/T/TC	86-87	SSH901	<b>713-040</b>
FJ1200W/WC/A/AC/B/BC/D/DC	89-92	SSH901	<b>713-040</b>
FJ1200AD/ADC/AE/AEC (ABS)	92-93	SSH901	<b>713-040</b>
VMX12N/NC/S/SC V-Max	85-86	SSH901	<b>713-040</b>
VMX12U/UC-V/VC V-Max	88-06	SSH901	<b>713-040</b>
XVZ12TK Venture	1983	SSH901	<b>713-040</b>
XVZ12TDK Venture Royale	1983	SSH901	<b>713-040</b>
XVZ12L/KC2 Venture	1984	SSH901	<b>713-040</b>
XVZ13DL/DN Venture Royale	84-85	SSH901	<b>713-040</b>
XVZ12DKC2 Venture Royale	1984	SSH901	<b>713-040</b>
XVZ13DS/DSC/DTC Venture Royale	86-87	SSH901	<b>713-040</b>
XVZ13T/TC/U/UC Venture	87-88	SSH901	<b>713-040</b>
XVZ13D Venture Royale	89-93	SSH901	<b>713-040</b>
XVZ13AH/AHC-AN/ANC Royal Star	96-01	SSH901	<b>713-040</b>
XVZ13AT Royal Star Tour Classic	96-00	SSH901	<b>713-040</b>
XVZ13LT Royal Star Tour Deluxe	97-01	SSH901	<b>713-040</b>
XVZ13TF Royal Star Venture	99-01	SSH901	<b>713-040</b>
XVZ13TFS Venture Limited Edition	2000	SSH901	<b>713-040</b>
XVZ1300CTT Royal Star Tour Deluxe	2005	SSH901	<b>713-040</b>
XVZ1300TFS Royal Star Midnight	02-04	SSH901	<b>713-040</b>
XVZ1300TFSMC Royal Star Venture	2000	SSH901	<b>713-040</b>
XVZ1300TF Royal Star Venture	99-04	SSH901	<b>713-040</b>
XV1600A Road Star	99-03	SSH901	<b>713-040</b>
XV1600AT Road Star Silverado	99-03	SSH901	<b>713-040</b>
XV1600 Road Star Limited Edition	2003	SSH901	<b>713-040</b>
XV1600AS Road Star Midnight	01-03	SSH901	<b>713-040</b>
XV1700AM Road Star Midnight	04-05	SSH901	<b>713-040</b>
XV1700AS/ASC/AT/ATC Road Star	04-05	SSH901	<b>713-040</b>
XV1700ATS/ATSC/ATT/ATTC	04-05	SSH901	<b>713-040</b>
XV1700AWT/AWTC Road Star	2005	SSH901	<b>713-040</b>

## Yamaha ATV

YT125N Tri-Moto	1985	SSY080	<b>713-210</b>
YT175J/K Tri-Moto	82-83	SSY080	<b>713-210</b>
YTM200K/EK Tri-Moto	1983	SSY080	<b>713-210</b>
YTM200N/ERN Tri-Moto	1984	SSY125	<b>713-230</b>
YTM225DXK/DXL/DXN Tri-Moto	83-85	SSY080	<b>713-210</b>
YTM225DRN/DRS Tri-Moto	85-86	SSY125	<b>713-230</b>

## Yamaha Dual Sport & Offroad

DT50U/W/A	88-90	SSY080	<b>713-210</b>
YZ50G	1980	SSY080	<b>713-210</b>
JT2/JT2MX-60 Mini	1972	SSY080	<b>713-210</b>
YZ60H/J/K	81-83	SSY080	<b>713-210</b>
BW80S/T/U/A	86-90	SSY080	<b>713-210</b>
DT80H/J/K	81-83	SSY080	<b>713-210</b>
GT80A-G	74-80	SSY080	<b>713-210</b>
GT1/GTMX-80	1973	SSY080	<b>713-210</b>

## Yamaha Dual Sport & Offroad

Model	Year	Mfg. Ref #	Order No.
GTMXA/MXB/MXC-80	74-76	SSY080	<b>713-210</b>
GTMXD/MXE/MXF-80	77-79	SSY080	<b>713-210</b>
MX80G/H/J	80-82	SSY080	<b>713-210</b>
TY80A/B Trials	74-75	SSY080	<b>713-210</b>
YZ80A/B/C/D/E/F/G/H/J/K	74-83	SSY080	<b>713-210</b>
HT1/HT1B/HT1BM-90 Enduro	70-71	SSY080	<b>713-210</b>
TT-R90M/MC-EV	00-06	SSY080	<b>713-210</b>
DT100A-K	74-83	SSY080	<b>713-210</b>
LT2/LT3-100	72-73	SSY080	<b>713-210</b>
LT2M/LT2MX-100	72-73	SSY080	<b>713-210</b>
MX100A/B	74-75	SSY080	<b>713-210</b>
MX100F/G/H/J/K	79-83	SSY080	<b>713-210</b>
RS100B/C	75-76	SSY080	<b>713-210</b>
RT100A-M	90-00	SSY080	<b>713-210</b>
YZ100C/D/E/F/G/H	76-81	SSY080	<b>713-210</b>
YZ100J/K	82-83	SSH901	<b>713-040</b>
AT1M/AT1MB-125	69-70	SSY080	<b>713-210</b>
AT1MX/AT2M/ATMX-125	71-73	SSY080	<b>713-210</b>
AT1E/AT1B/AT1C-125 Enduro	69-71	SSY080	<b>713-210</b>
AT2/AT3-125 Enduro	72-73	SSY080	<b>713-210</b>
DT125A-H Enduro	74-81	SSY080	<b>713-210</b>
IT125G/H	80-81	SSY080	<b>713-210</b>
MX125A/B/C	74-76	SSY080	<b>713-210</b>
XT125J/K/KC Dual Sport	82-83	SSY080	<b>713-210</b>
YZ125A/B/C/X	74-76	SSY080	<b>713-210</b>
YZ125D/E/F/G/H/J	77-82	SSH901	<b>713-040</b>
YZ125K/L/N/S	83-86	SSH901	<b>713-040</b>
YZ125T/U/W/A/B/D1	87-92	SSY901	_____
YZ125E1/F1/G1	93-95	SSY901	_____
YZ125H1-T1	96-05	SSY903T	_____
CT1/B1/C1/CT2/CT3 175 Enduro	69-73	SSY080	<b>713-210</b>
DT175A/B/C	74-76	SSY080	<b>713-210</b>
DT175F/G/H	79-81	SSY080	<b>713-210</b>
IT175D/E/F/G/H/J/K	77-83	SSH901	<b>713-040</b>
MX175A/B	74-75	SSY080	<b>713-210</b>
MX175G/H/J	79-81	SSY080	<b>713-210</b>
TY175B/C Trials	75-76	SSY080	<b>713-210</b>
YZ175C	1976	SSY080	<b>713-210</b>
BW200N/S/ES/ET/EU	85-88	SSY080	<b>713-210</b>
IT200L/N/S	84-86	SSH901	<b>713-040</b>
TW200T/TC-N/NC Trailway	87-01	SSY080	<b>713-210</b>
XT200J/K/KC Dual Sport	82-83	SSY080	<b>713-210</b>
DT1/DT1B/DT1S-250 Enduro	68-69	SSY080	<b>713-210</b>
DT1C/DT1E/DT2/DT3-250 Enduro	70-73	SSY080	<b>713-210</b>
DT250A/B/C/D/E/F Enduro	74-79	SSY080	<b>713-210</b>
DT1CMX/DT1MX-250	1971	SSY080	<b>713-210</b>
DT2MX-250	1972	SSY080	<b>713-210</b>
IT250D/E/F/G/H/J	77-82	SSH901	<b>713-040</b>
IT250K	1983	SSH901	<b>713-040</b>
MX250A/B	73-75	SSY080	<b>713-210</b>
TT250G/H/J	80-82	SSY080	<b>713-210</b>
TT250RL/RLC	1999	SSY901	_____
TT-R250N/NC-T/TC	01-05	SSY901	_____
TY250A/C/D Trials	74-77	SSY080	<b>713-210</b>
WR250FP/FR/FS/FT	02-05	SSY903T	_____
WR250ZB/ZD/ZE/ZF/ZG/ZH/ZJ	91-97	SSY901	_____
XT250G/H/J/K/KC Dual Sport	80-83	SSY080	<b>713-210</b>
XT250L/LC Dual Sport	1984	SSH901	<b>713-040</b>
YZ250A/B/C	74-76	SSY080	<b>713-210</b>
YZ250D/E/F/G/H/J	77-82	SSH901	<b>713-040</b>
YZ250K/L/N/S	83-86	SSH901	<b>713-040</b>
YZ250T-G1	87-95	SSY901	_____
YZ250H1-T1	96-05	SSY903T	_____

## Yamaha Dual Sport & Offroad

Model	Year	Mfg. Ref #	Order No.
YZ250FN-FV	01-06	SSY903T	_____
YZ250WRW/WRA	89-90	SSY901	_____
TT350S/T Offroad	86-87	SSH901	<b>713-040</b>
XT350N/NC-M/MC Dual Sport	85-00	SSH901	<b>713-040</b>
RT1M/RT1/RT2MX-360	70-72	SSY080	<b>713-210</b>
MX360/A	73-74	SSY080	<b>713-210</b>
RT1/RT1B/RT2/RT3-360 Enduro	70-73	SSY080	<b>713-210</b>
DT360A	1974	SSY080	<b>713-210</b>
YZ360A/B	74-75	SSY080	<b>713-210</b>
DT400B/C/D/E	75-78	SSY080	<b>713-210</b>
IT400C	1976	SSY080	<b>713-210</b>
IT400D/E/F	77-79	SSH901	<b>713-040</b>
MX400B	1975	SSY080	<b>713-210</b>
YZ400C	1976	SSY080	<b>713-210</b>
YZ400D/E/F	77-79	SSH901	<b>713-040</b>
YZ400FK/FL	98-99	SSY903T	_____
WR400FK/FL/FM	98-00	SSY903T	_____
IT425G	1980	SSH901	<b>713-040</b>
WR426FN/FP	01-02	SSY903T	_____
YZ426FM/FN/FP	00-02	SSY903T	_____
WR450FR/FS/FT/FV	03-06	SSY903T	_____
YZ450FR/FS/FT/FV	03-06	SSY903T	_____
IT465H/J	81-82	SSH901	<b>713-040</b>
YZ465G/H	80-81	SSH901	<b>713-040</b>
IT490K/L	83-84	SSH901	<b>713-040</b>
YZ490J/K/L/N/S/T/U/W/A	82-90	SSH901	<b>713-040</b>
SC500/A Scrambler	73-74	SSY080	<b>713-210</b>
TT500C/D/E/F/G/H Offroad	76-81	SSY080	<b>713-210</b>
XT500C/D/E/F/G/H Dual Sport	76-81	SSY080	<b>713-210</b>
WR500ZD/ZE	92-93	SSY901	_____
XT550J/K Dual Sport	82-83	SSH901	<b>713-040</b>
TT600K/L/N/S Offroad	83-86	SSH901	<b>713-040</b>
XT600L/LC-G/GC	84-95	SSH901	<b>713-040</b>



# Master Cylinder Rebuild Kits



850-120



850-131

## Master Cylinder Rebuild Kits

Complete kits contain all necessary components to rebuild one OEM master cylinder. *Made in Japan*

### Honda Street

Model	Year	Front	Rear
CB50R Dream	2004	850-102	—
NSR50R	2004	850-112	—
CB125TT	1990	850-102	—
CMX250C Rebel 250	85-87	850-112	—
CMX250C Rebel 250	96-97	850-112	—
CMX250C Rebel 250	99-09	850-112	—
CMX250C2 Rebel	99-00	850-112	—
CMX250CD Rebel 250 Limited	1986	850-112	—
CN250 Helix (Scooter)	86-87	850-102	—
CN250 Helix (Scooter)	92-01	850-102	—
CN250 Helix (Scooter)	04-07	850-102	—
NSS250 Reflex 250 (Scooter)	01-07	850-112	850-102
NSS250A Reflex 250 ABS (Scooter)	01-07	850-112	850-102
NSS250AS (Scooter)	04-07	850-112	850-102
NSS250S Reflex 250 Sport (Scooter)	04-07	850-112	850-102
PS250 Big Ruckus (Scooter)	05-06	850-112	850-102
VTR250R Interceptor	88-90	850-112	—
CB400F CB-1	89-90	—	850-122
CB400T Hawk	1981	850-102	—
CM400A Automatic	1981	850-102	—
CM400C Custom	1981	850-102	—
CM400T	1981	850-102	—
CB450SC Nighthawk	82-83	850-102	—
CB450SC Nighthawk	85-86	850-102	—
CB450T Hawk	1982	850-102	—
CM450A Automatic	82-83	850-102	—
CM450C Custom	82-83	850-102	—
CMX450C Rebel	86-87	850-112	—
CX500C Custom	81-82	850-102	—
CX500D Deluxe	1981	850-102	—
FT500 Ascot (Single Cylinder)	82-83	850-102	—
GB500	89-90	850-112	—
GL500 Silver Wing	81-82	850-102	—
VF500C Magna	84-85	850-102	—
VF500F Interceptor	84-86	—	850-120
VT500C Shadow	83-86	850-102	—
VT500FT Ascot	83-84	850-102	—
CB550SC Nighthawk	1983	850-102	—
CB600F (599)	2004	850-112	850-122
CB600F (599)	2006	850-112	850-122
CBR600F Hurricane	87-90	850-102	850-120
CBR600F2 Hurricane	91-94	850-112	850-120
CBR600F3 Hurricane	95-98	850-112	850-122
CBR600F4 Hurricane	99-00	—	850-122
CBR600F4i Hurricane	01-06	—	850-122
CBR600RA	09-10	—	850-122
CBR600SE	1998	850-112	850-122
CBR600SJR Replica	1996	850-112	850-122
CB650	81-82	850-102	—
CX650C Custom	1983	850-102	—
NT650 Hawk GT	88-91	850-112	850-120
XR650L Dual Sport	93-09	850-113	850-120
XR650L Dual Sport	2012	850-113	850-120

### Honda Street

Model	Year	Front	Rear
NSA700A	2009	850-102	—
VF700C Magna	1987	850-112	—
VF700F Interceptor	84-85	—	850-122
VFR700F/F2 Interceptor	86-87	—	850-120
VT700C Shadow	86-87	850-102	—
CB750K	69-76	850-103	—
CB750K	81-82	850-102	—
RVF750R (RC45)	1994	—	850-122
VF750C Magna	1988	850-112	—
VF750F Interceptor	83-84	—	850-122
VFR750F	90-97	850-112	850-120
VFR750F Interceptor	1986	—	850-120
VFR750R (RC30)	1990	—	850-122
PC800 Pacific Coast	89-90	850-102	—
PC800 Pacific Coast	94-98	850-102	—
VFR800	02-09	850-102	—
VFR800A (ABS)	02-09	850-102	—
VT800C Shadow	1988	850-112	—
CB900F (919)	02-06	850-102	850-120
CB1000	94-95	850-102	850-122
CBR1000F Hurricane	87-88	—	850-120
CBR1000F Hurricane	90-91	850-102	850-120
CBR1000RR	2006	—	850-122
RVT1000R (RC51)	00-06	—	850-122
VF1000F Interceptor	1984	—	850-122
VF1000R	85-86	—	850-120
VTR1000F Super Hawk	98-05	—	850-122
GL1100I Goldwing Interstate	1983	850-102	—
ST1100	91-02	850-102	850-120
ST1100A ABS	92-02	850-102	850-120
VT1100C Shadow Spirit	97-06	850-112	—
VT1100C2 Shadow 1100 ACE	95-99	850-112	850-120
VT1100C2 Shadow Sabre	00-06	850-112	850-120
VT1100C3 Shadow Aero	98-02	850-112	850-120
VT1100D2 Shadow 1100 ACE	1999	850-112	850-120
VT1100T Shadow 1100 ACE	98-01	850-112	850-120
GL1200A Gold Wing Aspencade	84-87	850-112	—
GL1200I Gold Wing Interstate	84-87	850-112	—
VTX1300C	04-06	—	850-120
VTX1300R	05-06	—	850-120
VTX1300S	03-04	850-112	850-120
VTX1300S	05-06	—	850-120
GL1500C Valkyrie	97-00	—	850-120
GL1500C Valkyrie	2003	—	850-120
GL1500CD Valkyrie	01-03	—	850-120
GL1500CF Valkyrie Interstate	99-01	—	850-120
GL1500CT Valkyrie Tourer	97-00	—	850-120
VTX1800C	02-04	850-102	—
VTX1800C1	05-07	850-102	—
VTX1800C2	05-06	850-102	—
VTX1800C3	05-06	850-102	—
VTX1800F1	05-08	850-102	—
VTX1800F2	05-07	850-102	—
VTX1800F3	05-08	850-102	—
VTX1800N1	04-08	850-102	—
VTX1800N2	04-07	850-102	—
VTX1800N3	04-08	850-102	—



## Honda Street

Model	Year	Front	Rear
VTX1800R	02-03	850-102	_____
VTX1800R1	04-07	850-102	_____
VTX1800R2	04-07	850-102	_____
VTX1800R3	04-07	850-102	_____
VTX1800S	02-03	850-102	_____
VTX1800S1	04-06	850-102	_____
VTX1800S2	04-06	850-102	_____
VTX1800S3	04-06	850-102	_____
VTX1800T1	07-08	850-102	_____
VTX1800T2	2007	850-102	_____
VTX1800T3	2008	850-102	_____

## Honda ATV

ATC200X	86-87	850-112	850-122
TRX200 Fourtrax 200	1984	850-112	_____
TRX200 Fourtrax 200	90-91	850-112	_____
TRX200D Fourtrax Type II	91-97	850-112	_____
TRX200SX Fourtrax	86-88	850-112	_____
ATC250R	85-86	850-112	_____
TRX250 Fourtrax 250	85-86	850-112	_____
TRX250 Recon	97-01	850-112	_____
TRX250EX Sportrax 250EX	01-06	850-112	_____
TRX250TE Fourtrax Recon ES	02-06	850-112	_____
TRX250TM Fourtrax Recon	02-06	850-112	_____
TRX250R Fourtrax 250R	1986	_____	850-122
TRX250R Fourtrax 250R	87-89	850-113	850-122
TRX250X Fourtrax	87-88	850-113	850-120
TRX250X Fourtrax	91-92	850-113	850-120
TRX300 Fourtrax 300	88-00	850-112	_____
TRX300EX Fourtrax 300EX	93-00	850-113	850-120
TRX300EX Sportrax 300EX	01-04	850-113	850-120
TRX300EX Sportrax 300EX	05-06	850-112	850-120
TRX300FW Fourtrax 300 4x4	1988	850-114	_____
TRX300FW Fourtrax 300 4x4	90-00	850-114	_____
ATC350X	85-86	850-112	_____
TRX350 Fourtrax 4x4	86-87	850-112	_____
TRX350D Fourtrax Fourman 4x4	1987	850-112	_____
TRX350FE Rancher 4x4 ES	00-03	850-112	_____
TRX350FM Fourtrax Rancher 4x4	00-03	850-112	_____
TRX350TE Fourtrax Rancher ES	00-03	850-112	_____
TRX350TM Fourtrax Rancher	00-03	850-112	_____
TRX400EX Fourtrax 400 EX	99-00	850-112	850-122
TRX400EX Sportrax 400 EX	01-06	850-112	850-122
TRX400FW Fourtrax Foreman	95-03	850-114	_____
TRX450ER	2006	_____	850-120
TRX450FE Fourtrax Foreman ES	02-04	850-114	_____
TRX450FM Fourtrax Foreman S	02-05	850-114	_____
TRX450R	04-06	_____	850-120
TRX450S	98-01	850-114	_____
TRX500FA Foreman Rubicon	01-04	850-114	_____
TRX500FGA Foreman Rubicon GPS	2004	850-114	_____

## Honda Dual Sport & Offroad

CR80R	92-97	_____	850-120
CR80R	98-99	850-111	850-120
CR80R	00-02	850-110	850-120
CR80RB Expert	92-97	_____	850-120
CR80RB Expert	98-99	850-111	850-120
CR80RB Expert	00-02	850-110	850-120
CR85R	03-07	850-110	850-120
CR85RB Expert	03-07	850-110	850-120
CR125R	1986	850-111	_____
CR125R	87-99	850-111	850-120
CR125R	00-01	850-110	850-120
CR125R	02-07	850-110	850-121
CRF150R	07-09	850-110	_____
CRF150R	2012	850-110	_____
CRF150RB	07-09	850-110	_____
CRF150RB	2012	850-110	_____
CRF230L Dual Sport	08-09	_____	850-122

## Honda Dual Sport & Offroad

Model	Year	Front	Rear
CRF230M Motard	2009	_____	850-122
CR250R	1986	850-111	_____
CR250R	87-99	850-111	850-120
CR250R	00-01	850-110	850-120
CR250R	02-07	850-110	850-121
CRF250R	04-06	850-110	850-121
CRF250R	07-12	_____	850-121
CRF250X	04-06	850-110	850-121
CRF250X	07-09	850-110	850-121
NX250	88-90	_____	_____
XR250L Dual Sport	91-96	850-113	850-121
XR250R	86-89	_____	_____
XR250R	90-95	_____	850-120
XR250R	96-99	850-111	850-122
XR250R	00-04	850-110	850-122
XR350R	1985	850-111	_____
XR400R	96-99	850-111	850-120
XR400R	00-04	850-110	850-120
CRF450R	02-06	850-110	850-121
CRF450R	07-12	_____	850-121
CRF450X	05-09	850-110	850-121
CRF450X	2012	850-110	850-121
CR500R	1986	850-111	_____
CR500R	87-99	850-111	850-120
CR500R	00-01	850-110	850-120
XR600R	1985	850-111	_____
XR600R	86-90	_____	_____
XR600R	91-00	_____	850-120
XR650L Dual Sport	93-09	850-113	850-120
XR650L Dual Sport	2012	850-113	850-120
XR650R	00-07	850-110	850-120

## Kawasaki Street

S2/S2A-350 2-stroke triple	72-73	850-100	_____
S3/S3A-400 2-stroke triple	74-75	850-100	_____
KH400A3/A4 2-stroke triple	76-77	850-100	_____
KLX400A1 KLX400SR Dual Sport	2003	_____	850-110
KZ400A1/A2	77-78	850-100	_____
KZ400/D/D3/D4	74-77	850-100	_____
EX500D1/D2/D3 Ninja 500	94-96	850-170	850-171
EX500D4-D12 Ninja 500R	97-05	850-170	850-171
EX500D6F/D7F Ninja 500R	06-07	850-170	850-171
H1B 500 2-stroke triple	1972	850-100	_____
H1D/H1E/H1F 500 2-stroke triple	73-75	850-100	_____
KH500A8 2-stroke triple	1976	850-100	_____
ZR550B1/B2 Zephyr	90-91	_____	850-171
ZR550B3/B4 (Canada)	92-93	_____	850-171
ZX600E1-E10 Ninja ZX-6	93-02	_____	850-171
ZX600E11/E12 ZZR600	03-04	_____	850-171
ZX600F1/F2/F3 Ninja ZX-6R	95-97	_____	850-171
ZX600G1 Ninja ZX-6R	1998	_____	850-171
ZX600K1 Ninja ZX-6RR	2003	850-170	_____
ZX600M1 Ninja ZX-6RR	2004	850-170	_____
ZX636B1/B2 Ninja ZX-6R	03-04	850-170	_____
EX650A6F/A7F Ninja 650R	06-07	_____	850-171
KL650A1-A19 KLR650	87-05	_____	850-171
KL650A6F/A7F KLR650	06-07	_____	850-171
KL650B2/B3 Tengai KLR	90-91	_____	850-171
KZ650B1	1977	850-100	_____
H2/A/B/C-750 2-stroke triple	72-75	850-100	_____
ZX750J1/J2 Ninja ZX-7	91-92	_____	850-171
ZX750K1/K2 Ninja ZX-7R	91-92	_____	850-171
ZX750L1/L2/L3 Ninja ZX-7	93-95	_____	850-171
ZX750M1/M2 Ninja ZX-7R	93-94	_____	850-171
VN800C2 Vulcan 800 Drifter 2000	2000	850-170	_____
VN800E1-E6F Vulcan 800 Drifter	01-08	850-170	_____
Z1/Z1A/Z1B-900	73-75	850-100	_____
KZ900A4/A5	76-77	850-100	_____
ZX900B1/B2/B3/B4 Ninja ZX-9R	94-97	_____	850-171
ZX900C1/C2 Ninja ZX-9R	98-99	_____	850-171

# Master Cylinder Rebuild Kits

## Kawasaki Street

Model	Year	Front	Rear
ZX900E1/E2 Ninja ZX-9R	00-01	————	<b>850-171</b>
ZX900F1/F2 Ninja ZX-9R	02-03	————	<b>850-171</b>
KZ1000A1	1977	<b>850-100</b>	————
ZR1000A1/A2/A3 Z1000	03-05	————	<b>850-171</b>
ZX1100E1/E2/E3 Gpz	95-97	————	<b>850-171</b>
ZX1100F1 GPz (ABS)	1996	————	<b>850-171</b>
VN1500J1/J2 Vulcan 1500 Drifter	99-00	<b>850-170</b>	————
VN1500N1/N2/N3 Vulcan 1500 Classic F.I.	00-02	<b>850-170</b>	————
VN1500R1-R5 Vulcan 1500 Drifter	01-05	<b>850-170</b>	————

## Kawasaki ATV

KSF250A1 Mojave	1987	————	<b>850-171</b>
KSF250A2-A17 Mojave	88-03	<b>850-170</b>	<b>850-171</b>
KSF250A18 KFX250	2004	<b>850-170</b>	<b>850-171</b>
KXF250A1/A2 Tecate 4	87-88	————	<b>850-171</b>
KXT250B2 Tecate 3	1987	————	————
KEF300A1-A6 Lakota 300	95-00	<b>850-170</b>	<b>850-171</b>
KEF300B1/B2/B3 Lakota Sport	01-03	<b>850-170</b>	<b>850-171</b>
KLF300A1/A2 Bayou	86-87	<b>850-170</b>	————
KLF300B1-B17 Bayou 300	88-04	<b>850-170</b>	————
KLF300C1-C16 Bayou 300 4x4	89-04	<b>850-170</b>	————
KVF300A1-A4 Prairie 300 4x4	99-02	<b>850-170</b>	————
KVF300B1-B4 Prairie 300	99-02	<b>850-170</b>	————
KVF360A1/A2/A3 Prairie 360 4x4	03-05	<b>850-170</b>	————
KVF360A6F/A7F Prairie 360 4x4	06-07	<b>850-170</b>	————
KVF360B1/B2/B3 Prairie 360	03-05	<b>850-170</b>	————
KVF360B6F/B7F Prairie 360	06-07	<b>850-170</b>	————
KVF360C1 Prairie 360 4x4	2003	<b>850-170</b>	————
Advantage Classic			
KVF360C2/C3 Prairie 360 4x4 Hardwoods	04-05	<b>850-170</b>	————
KVF360C6F/C7F Prairie 360 4x4 Hardwoods	06-07	<b>850-170</b>	————
KLF400B1-B7 Bayou 4x4	93-99	<b>850-170</b>	————
KSF400A1/A2/A3/A6F KFX400	03-06	<b>850-150</b>	————
KVF400A1/A2 Prairie 400 4x4	97-98	<b>850-170</b>	————
KVF400B1 Prairie 400 2x4	1998	<b>850-170</b>	————
KVF400C1-C4 Prairie 400 4x4	99-02	<b>850-170</b>	————
KVF400D1-D4 Prairie 400	99-02	<b>850-170</b>	————
KSF450B8F/BFA/B9F KFX450R	08-09	————	<b>850-171</b>
KSF450B9FB KFX450R Monster Energy	2009	————	<b>850-171</b>
KSF450BAF/BBF KFX450R	10-11	————	<b>850-171</b>
KVF650A1/A2 Prairie 650 4x4	02-03	<b>850-170</b>	————
KVF650B1/B2 Prairie 650 4x4 Advantage	02-03	<b>850-170</b>	————
KVF650D1/D6F/D7F Brute Force 650 4x4	05-07	<b>850-170</b>	————
KVF650E1/E6F/E7F	05-07	<b>850-170</b>	————
Brute Force 650 4x4 Hardwoods			
KSV700A1/A2/A6F/A7F KFX700 V-Force	04-07	<b>850-170</b>	————
KSV700B1/B2/B6F/B7F KFX700 V-Force	04-07	<b>850-170</b>	————
KSV700C6F KFX700 V-Force	2006	<b>850-170</b>	————
KVF700A1/A2/A6F Prairie 700 4x4	04-06	<b>850-170</b>	————
KVF700B1/B2 Prairie 700 4x4 Hardwoods	04-05	<b>850-170</b>	————

## Kawasaki Dual Sport & Offroad

KX65A1/A2/A3/A4/A5/A6F/A7F	00-07	————	<b>850-171</b>
KX80L1/L2/L3	88-90	————	<b>850-171</b>
KX80N1/N2/N3	88-90	————	<b>850-171</b>
KX80R1/R2/R3	91-93	————	<b>850-171</b>
KX80T1/T2/T3	91-93	————	<b>850-171</b>
KX80T4/R4/R5/R6/R7	94-97	————	<b>850-171</b>
KX80W1/W2/W3	98-00	————	<b>850-171</b>
KX85A1/A2/A3/A4/A5	01-05	<b>850-181</b>	<b>850-171</b>
KX85A6F/A7F	06-07	<b>850-181</b>	<b>850-171</b>
KX100B5/B6/B7	95-97	————	<b>850-171</b>
KX100C1/C2/C3	98-00	————	<b>850-171</b>
KX100D1/D2/D3/D4/D5	01-05	<b>850-181</b>	<b>850-171</b>
KX100D6F/D7F	06-07	<b>850-181</b>	<b>850-171</b>
KX125E1	1986	————	<b>850-171</b>
KX125E2/F1/G1	87-90	————	<b>850-171</b>
KX125K1/K2/K3	94-96	————	<b>850-171</b>

## Kawasaki Dual Sport & Offroad

Model	Year	Front	Rear
KX125K4/K5/L1	97-99	<b>850-180</b>	<b>850-171</b>
KX125L2	2000	————	<b>850-171</b>
KX125L3/L4	01-02	<b>850-181</b>	<b>850-171</b>
KX125M1/M2/M3	03-05	<b>850-181</b>	<b>850-171</b>
KDX200E1/E2/E3/E4/E5/E6	89-94	————	<b>850-171</b>
KDX200H1-H11	95-05	————	<b>850-171</b>
KDX220A4-A12	97-05	————	<b>850-171</b>
KL250G4-G7 Super Sherpa	00-03	————	<b>850-171</b>
KX250D2	1986	————	<b>850-171</b>
KX250E1/F1/G1	87-89	————	<b>850-171</b>
KX250H1/H2	90-91	————	<b>850-171</b>
KX250K1/K2/K3	94-96	————	<b>850-171</b>
KX250K4/K5/L1	97-99	<b>850-180</b>	<b>850-171</b>
KX250L2	2000	————	<b>850-171</b>
KX250L3/L4	01-02	<b>850-181</b>	<b>850-171</b>
KX250M1/M2/M3	03-05	<b>850-181</b>	<b>850-171</b>
KX250N1/N2 KX250F	04-05	<b>850-181</b>	<b>850-171</b>
KX250R6F/R7F	06-07	<b>850-181</b>	<b>850-171</b>
KX250T6F/T7F KX250F	06-07	<b>850-181</b>	<b>850-171</b>
KLX300A2-A10	97-05	————	<b>850-171</b>
KLX300A6F/A7F	06-07	————	<b>850-171</b>
KLX400A1/A1L KLX400SR Dual Sport	2003	<b>850-110</b>	————
KLX400B1 KLX400R Offroad	2003	<b>850-110</b>	————
KX450D6F/D7F	06-07	<b>850-181</b>	<b>850-171</b>
KX500B2	1986	————	<b>850-171</b>
KX500C1/D1	87-88	————	<b>850-171</b>
KX500E1/E2	89-90	————	<b>850-171</b>
KX500E3/E4/E5	91-93	————	————
KX500E6-E15	94-03	————	<b>850-171</b>
KX500E16	2004	<b>850-181</b>	<b>850-171</b>
KL650A1-A19 KLR650	87-05	————	<b>850-171</b>
KL650A6F/A7F KLR650	06-07	————	<b>850-171</b>
KL650B2/B3 Tengai KLR650	90-91	————	<b>850-171</b>
KLX650A1/A2/A3 KLX650R	93-95	————	<b>850-171</b>
KLX650C1/C2/C3/C4 Dual Sport	93-96	————	<b>850-171</b>
KLX650D1 KLX650R Offroad	1996	————	<b>850-171</b>

## Suzuki Street

GN125EV	1997	<b>850-150</b>	————
DR-Z400SY/SK1-SK7	00-07	<b>850-110</b>	<b>850-120</b>
DR-Z400SMK5/SMK6 Supermotard	05-06	<b>850-110</b>	<b>850-120</b>
GSF400M/N/P Bandit	91-93	<b>850-150</b>	<b>850-120</b>
GS500EK-EK2	89-02	<b>850-150</b>	<b>850-120</b>
GS550LD	1983	<b>850-150</b>	————
GS550LF/LG	85-86	<b>850-150</b>	————
GSF600ST/SV/SW/SX Bandit	96-99	<b>850-151</b>	<b>850-120</b>
GSF600SY/SK1/SK2/SK3 Bandit	00-03	————	<b>850-120</b>
GSX600FJ Katana	1988	<b>850-151</b>	<b>850-120</b>
GSX600FK-FV Katana	89-97	————	<b>850-120</b>
GSX600FW-FK6 Katana	98-06	<b>850-151</b>	<b>850-120</b>
GSX-R600WN/WP	92-93	————	<b>850-120</b>
GSX-R600V/W/X/Y	97-00	<b>850-151</b>	<b>850-120</b>
GSX-R600K1/K2/K3	01-03	————	<b>850-120</b>
RF600RR/RS/RT	94-96	<b>850-150</b>	<b>850-120</b>
RF900RR/RS/RT/RV	94-97	————	<b>850-120</b>
DR650SL/SM/SN/SP/SER/SES Dual	90-95	<b>850-151</b>	————
DR650SET-SEK7 Dual Sport	96-07	<b>850-150</b>	<b>850-120</b>
GS650GLD	1983	<b>850-151</b>	————
LS650FG/FH Savage	86-87	<b>850-150</b>	————
LS650PG/PH/PJ Savage	86-88	<b>850-150</b>	————
LS650PS-PK4 Savage	95-04	<b>850-150</b>	————
LS650 Boulevard S40	05-07	<b>850-150</b>	————
SV650X/Y/K1/K2	99-02	————	<b>850-120</b>
SV650SX/SY/SK1/SK2	99-02	————	<b>850-120</b>
VS700GLEFG/GLEFH Intruder	86-87	<b>850-151</b>	————
VS700GLEPG/GLEPH Intruder	86-87	<b>850-151</b>	————
VS700GLFG/GLFH Intruder	86-87	<b>850-151</b>	————

## Suzuki Street

Model	Year	Front	Rear
VS700GLPG/GLPH Intruder	86-87	850-151	—
GSX750FK-FK6 Katana	89-06	850-151	850-120
GSX-R750G/H	86-87	—	850-160
GSX-R750J/K	88-89	850-151	850-160
GSX-R750L/M/N	90-92	—	850-160
GSX-R750WP/WR/WS	93-95	—	850-120
GSX-R750TV/W/X/Y	96-00	—	850-120
GSX-R750K1-K6	01-03	—	850-120
VS750GLPJ-GLPM Intruder	88-91	850-150	—
VL800K1-K4 Volusia	01-04	850-150	—
VS800GLN-GLK4 Intruder	92-04	850-150	—
VS800G Boulevard S50	05-06	850-150	—
VX800L/M/N/P	90-93	850-150	—
VZ800V-K4 Marauder	97-04	850-150	—
VZ800K5/K6 Boulevard M50	05-06	850-150	—
RF900RR/RS/RT/RV	94-97	—	850-120
RF900RZS	1995	—	850-120
GSX-R1000K1/K2	00-02	—	850-120
TL1000RW-RK3	98-03	—	850-120
TL1000SV/SW/SX/SY/SK1	97-01	850-151	850-120
GSX1100FJ-FP Katana	88-93	850-151	850-120
GSX1100GM/GN/GP Shaft	91-93	—	850-120
GSX-R1100G/H	86-87	—	850-160
GSX-R1100J/K	88-89	850-151	850-160
GSX-R1100K/L/M/N	89-92	850-151	—
GSX-R1100WP-WW	93-98	—	850-120
GSF1200SAV Bandit	1997	—	850-120
GSF1200SV/SW/SX/SY Bandit	97-00	—	850-120
GSF1200SK1-SK5 Bandit	01-05	—	850-120
GSX1300RK-RK6 Hayabusa	99-06	—	850-120
GV1400GCG/GCH Cavalcade LX	86-87	—	850-120
GV1400GDG/GDH/GDJ Cavalcade LX	86-88	—	850-120
GV1400GTG/GTH Cavalcade	86-87	—	850-120
VL1500W-K1 Intruder 1500 LC	98-01	850-150	—
VL1500K2/K3/K4 Intruder 1500 LC	02-04	—	850-120
VL1500LC Boulevard C90	05-06	—	850-120
VL1500LC Boulevard C90T	2006	—	850-120

## Suzuki ATV

LT230EH-EP Quadrunner	87-93	850-150	850-160
LT230GEF/GEG Quadrunner	85-86	850-150	—
LT230SF/SG/SH/SJ Quadsport	85-88	850-150	850-160
LTF230G/H Quadrunner	86-87	850-150	—
LT250EFF/EFG	85-86	850-151	—
LT250RF-RN Quadracer	85-92	850-150	850-160
LT250SK/SL Quadrunner	89-90	850-150	850-160
LT-Z250K4/K5/K6/K7 Quadsport	04-07	850-150	—
LT300EH/EJ/EK Quadrunner	87-89	850-150	—
LT-4WDH Quadrunner	1987	850-150	—
LT-Z400K3/K4/K5/K6/K7 Quadsport	03-07	850-150	—
LT500RH/RJ/RK/RL Quadracer	87-90	850-150	850-160
LT-A500FY Vinson 4WD	2000	850-151	—
LT-F500FW-FK2 Quadrunner	98-02	850-151	—

## Suzuki Dual Sport & Offroad

RM85K2/K3/K4	02-04	—	850-120
RM85K5/K6/K7/K8/K9/L0	05-10	850-152	850-120
RM85LK2/LK3/LK4	02-04	—	850-120
RM85LK5/LK6/LK7/LK8/LK9/LK0	05-10	850-152	850-120
RM125J	1988	—	850-160
RM125K/L/M	89-91	—	850-160
RM125N	1992	—	850-120
RM125TV/W/X/Y/K1/K2/K3	96-03	850-153	850-120
RM125K4/K5/K6/K7/K8	04-08	850-152	850-120
DR250L/M/N/P	90-93	—	850-120
DR250SL/SM/SN/SP/SER/SES Dual Sport	90-95	850-110	850-120
RM250TV/W/X/Y/K1/K2/K3	96-03	850-153	850-120
RM250K4/K5/K6/K7	04-07	850-152	850-120

## Suzuki Dual Sport & Offroad

Model	Year	Front	Rear
RM-Z250K4/K5/K6	04-06	850-181	850-171
DR350L-X Offroad	90-99	—	850-120
DR350SL-SEX Dual Sport	90-99	850-110	850-120
DR-Z400Y/K1-K6	00-06	850-153	850-120
DR-Z400EY/EK1-EK7	00-07	850-153	850-120
DR-Z400SY/SK1-SK7 Dual Sport	00-07	850-110	850-120
DR-Z400SMK5/SMK6 Supermotard	05-06	850-110	850-120
RM-Z450K5-K9/L0/L1/L2/L3	05-13	850-152	—
DR650SL/SM/SN/SP/SER/SES Dual Sport	90-95	850-151	—
DR650SET-SEK7 Dual Sport	96-07	850-150	850-120

## Yamaha Street

YSR50T/U/W/A/B/D	87-92	850-107	—
RX50K/L	83-84	850-105	—
RX50MK	1983	850-105	—
SRX250T/TC	1987	850-108	—
XV250U/UC/W/WC/A/AC Route66	88-90	850-108	—
XV250G-X	95-08	850-108	—
XV250RC/XR/YCR/YR	08-09	850-108	—
RZ350L/N/NC/NCII	84-85	850-133	850-144
XS400J/K Maxim	82-83	850-108	—
XS400RJ/RK Seca	82-83	850-108	—
XV500K Virago	1983	850-108	—
XV535T/TC/U/UC Virago 535	87-88	850-105	—
XV535A/AC Virago 535	1990	850-105	—
XV535E/EC-M/MC Virago 535	93-00	850-105	—
XV535SF/SFC/SG/SGC Virago 535	94-95	850-105	—
XV535SJ/SJC Virago 535	1997	850-105	—
XJ550H/J/K Maxim	81-83	850-108	—
XJ550RH/RJ/RK Seca	81-83	850-108	—
XZ550RJ Vision	1982	850-108	—
XZ550RK Vision	1983	850-133	—
XJ650G/H/J/K Maxim	80-83	850-105	—
XJ650LH Midnight Maxim	1981	850-105	—
XJ650LJ/LK Seca Turbo	82-83	850-133	—
XJ650RJ Seca	1982	850-133	—
XJ700N/NC/S/SC Maxim	85-86	850-133	—
XJ700XN/XNC/XS/XSC Maxim X	85-86	850-133	—
XV700L/LC/N/NC Virago	84-85	850-133	—
XV700CS/CSC/CT/CTC Virago	86-87	850-133	—
XV700SS/SSC Virago	1986	850-133	—
XJ750J/K Maxim	82-83	850-133	—
XJ750MK Midnight Maxim	1983	850-133	—
XV750H/J/K Virago 750	81-83	850-105	—
XV750MK Midnight Virago 750	1983	850-105	—
XV750U/UC-H/HC Virago	88-96	850-133	—
XV750H1/H1C/J11/J1C Virago	96-97	850-133	—
XJ900RK Seca	1983	850-133	—
XV920J Virago	1982	850-133	—
XV920K Virago	1983	850-105	—
XV920MK Midnight Virago	1983	850-105	—
XV920RH/RJ	81-82	850-133	—
FZR1000W/WC/A/AC	89-90	850-133	850-143
FZR1000B/BC-G/GC	91-95	—	850-143
XV1000L/LC/N/NC Virago	84-85	850-133	—
XJ1100J Maxim	1982	850-105	—
XS1100LH	1981	850-105	—
XV1100S/SC-L/LC Virago	86-99	850-133	—
XV1100SH/SHC-SK/SKC Virago	96-98	850-133	—
XVZ12KC/KC2/DL/DK/TK/DN	83-85	850-108	—
XVZ1200L/LC/DL/DN	84-85	850-108	—
XVZ1300AH/AHC/AJ/AJC/AK/AKC	96-98	850-133	—
Royal Star			
XVZ1300AL/ALC/AM/AMC/AN/ANC	99-01	850-133	—
Boulevard			
XVZ1300ATH/ATHC-ATM/ATMC	96-00	850-133	—
Royal Star Tour Classic			
XVZ1300CTT/CTTC Royal Star Tour Deluxe	2005	850-133	—
XVZ1300CTV/CTVC Royal Star Tour Deluxe	2006	850-133	—
XVZ1300CTMVC Royal Star	2006	850-133	—

# Master Cylinder Rebuild Kits

## Yamaha Street

Model	Year	Front	Rear
XVZ1300LTJ/LTJC-LTN/LTNC	97-01	<b>850-133</b>	_____
Royal Star Tour Deluxe			
XVZ1300TFSMC Royal Star Venture MM	2000	<b>850-133</b>	_____
XVZ1300TFL/TFCL-TFV/TFVC	99-06	<b>850-133</b>	_____
Royal Star Venture			
VZ1300TFSP/TFSPC-TFMV/TFMVC	02-06	<b>850-133</b>	_____
Royal Star Midnight Venture			
XV1600AL/ALC-AR/ARC Road Star	99-03	<b>850-133</b>	_____
XV1600ATL/ATLC-ATR-ATRC	99-03	<b>850-133</b>	_____
Road Star Silverado			
XV1600ASM/ASMC Road Star MM Limited	2000	<b>850-133</b>	_____
XV1600ASN/ASNC-ASR/ASRC	01-03	<b>850-133</b>	_____
Road Star Midnight			
XV1600ALER/ALERC	2003	<b>850-133</b>	_____
Road Star Limited Edition			
XXV1600ATLER/ATLERC	2003	<b>850-133</b>	_____
Road Star Silverado Limited Edition			

## Yamaha ATV

YTZ250N Tri-Z	1985	<b>850-108</b>	<b>850-144</b>
YTZ250S Tri-Z	1986	_____	<b>850-144</b>
YFM350FHL/FHLC Big Bear	1999	<b>850-133</b>	_____
4WD Hunter			
YFM350FWBJ/FWBK/FWBKC	97-98	<b>850-132</b>	_____
Big Bear 4WD			
YFM350FWBL/FWBLC Big Bear 4WD	1999	<b>850-133</b>	_____
YFM350FWH Big Bear 4WD	1996	<b>850-132</b>	_____
YFM350FWT-FWG Big Bear 4WD	87-95	<b>850-132</b>	_____
YFM350FXG/FXH/FXJ/FXK	95-98	<b>850-132</b>	_____
Wolverine 4WD			
YFM350FXL/FXLC/FXM/FXMC	99-00	<b>850-132</b>	_____
Wolverine 4WD			
YFM350FXN Wolverine 4WD	2001	<b>850-132</b>	_____
YFM350FXP/FXR Wolverine 4WD	02-03	_____	_____
YFM350UH/UJ Big Bear 2WD	96-97	<b>850-132</b>	_____
YFM350UL/ULC Big Bear 2x4	1999	<b>850-133</b>	_____
YFM350XT Warrior	1987	_____	<b>850-144</b>
YFM350XU/XW Warrior	88-89	<b>850-132</b>	<b>850-144</b>
YFM350XA-XS/XSC Warrior	90-01	<b>850-132</b>	<b>850-143</b>
YFM350XP/XPC-XS/XSC Warrior	02-04	<b>850-134</b>	<b>850-143</b>
YFZ350T-N Banshee	87-01	<b>850-132</b>	<b>850-144</b>
YFZ350P/R/S/T/V Banshee	02-06	<b>850-134</b>	_____
YFZ350LER/LES Banshee L.E.	03-04	<b>850-134</b>	_____
YFZ350RB Banshee Limited Edition	2003	<b>850-134</b>	_____
YFZ350SET/SEV Banshee SE	05-06	<b>850-134</b>	_____
YFZ350SPV Banshee SP	2006	<b>850-134</b>	_____
YFM350RS/RT/RV Raptor 350	04-06	<b>850-134</b>	_____
YFM350RSET/RSEV Raptor 350 SE	05-06	<b>850-134</b>	_____
YFM400AM/AMC/AN/ANC Kodiak 2WD	00-01	<b>850-132</b>	_____
YFM400FAHM/FAHMC Kodiak	2000	<b>850-132</b>	_____
4WD Hunter			
YFM400FAHN Kodiak 4WD	2001	<b>850-132</b>	_____
Real Tree Hunter			
YFM400FAM/FAMC/FAN Kodiak 4WD	00-01	<b>850-132</b>	_____
YFM400FHM Big Bear Buckmaster 4WD	2000	<b>850-132</b>	_____
YFM400FM/FMC Big Bear 4WD	2000	<b>850-132</b>	_____
YFM400FWE/FWF/FWG Kodiak 4WD	93-95	<b>850-132</b>	_____
YFM400FWH/FWJ/FWK Kodiak 4WD	96-98	<b>850-132</b>	_____
YFM400FWBL/FWBLC Kodiak 4WD	1999	<b>850-133</b>	_____
YFM400HN Big Bear 2WD	2001	<b>850-132</b>	_____
Real Tree Hunter			
YFM400NM/NMC Big Bear 2WD	2000	<b>850-132</b>	_____
YFZ450S/T/V	04-06	<b>850-134</b>	<b>850-145</b>
YFZ450BBV Bill Balance Edition	2006	<b>850-134</b>	<b>850-145</b>
YFZ450LES Limited Edition	2004	<b>850-134</b>	<b>850-145</b>
YFZ450SET Special Edition	2005	<b>850-134</b>	<b>850-145</b>
YFZ450SPV Special Edition	2006	<b>850-134</b>	<b>850-145</b>
YFM600FWAK/FWAKC Grizzly	98-99	<b>850-133</b>	_____

## Yamaha ATV

Model	Year	Front	Rear
YFM600FM/FMC/FN Grizzly	00-01	<b>850-133</b>	_____
YFM600FWMH/FWHMC	2000	<b>850-133</b>	_____
Grizzly Real Tree			
YFM600FHN Grizzly Real Tree Hunter	2001	<b>850-133</b>	_____
YFM660RN/RNC/RP Raptor 660R	01-02	<b>850-134</b>	<b>850-145</b>
YFM660RR/RS/RT Raptor 660R	03-05	<b>850-134</b>	<b>850-145</b>
YFM660RLER Raptor 660R	2003	<b>850-134</b>	<b>850-145</b>
Limited Edition			
YFM660RLES Raptor 660R	2004	<b>850-134</b>	<b>850-145</b>
Limited Edition			
YFM660RSET Raptor SE	2005	<b>850-134</b>	<b>850-145</b>
YFM700RV Raptor 700	2006	<b>850-134</b>	<b>850-145</b>
YFM700RSPV Raptor 700	2006	<b>850-134</b>	<b>850-145</b>

## Yamaha Dual Sport & Offroad

YZ80S/T/U/W/A/B/D	86-90	<b>850-107</b>	_____
YZ80E1/F1/G1/H1	93-96	<b>850-107</b>	<b>850-140</b>
YZ80J1/K1/L1/M1	97-00	_____	<b>850-140</b>
YZ80N1	2001	<b>850-130</b>	<b>850-140</b>
YZ85P/R/S/T/V	02-06	<b>850-131</b>	<b>850-140</b>
YZ125U/W	88-89	_____	<b>850-140</b>
YZ125A/B/D1/E1/F1/G1	90-95	_____	<b>850-140</b>
YZ125H1/J1/K1/L1/M1	96-00	_____	<b>850-141</b>
YZ125N	1985	<b>850-107</b>	_____
YZ125S/T/U/W	86-89	<b>850-107</b>	_____
YZ125N1	2001	<b>850-130</b>	<b>850-141</b>
YZ125P	2002	<b>850-131</b>	<b>850-141</b>
YZ125R/S/T/V	03-06	<b>850-131</b>	<b>850-142</b>
IT200S	1986	<b>850-107</b>	_____
WR200RD	1992	_____	<b>850-140</b>
TT225L/LC	1999	<b>850-107</b>	_____
TT-R230T/TC/V	05-06	<b>850-131</b>	_____
TT250RL/RLC	1999	_____	<b>850-144</b>
TT-R250M/MC/N/NC/P/PC	00-02	_____	<b>850-144</b>
TT-R250R/RC/S/SC/T/TC/V/C	03-06	<b>875-107</b>	<b>850-144</b>
TT-R250R/RC/S/SC/T/TC/V/C	03-06	<b>875-107</b>	<b>850-144</b>
WR250ZB/ZD/ZE/ZF/ZG/ZH	91-96	_____	<b>850-140</b>
WR250ZJ	1997	_____	<b>850-141</b>
WR250FN	2001	<b>850-130</b>	<b>850-141</b>
WR250FP	2002	<b>850-131</b>	<b>850-141</b>
WR250FR/FS/FT/FV	03-06	<b>850-131</b>	<b>850-142</b>
YZ250FN	2001	<b>850-130</b>	<b>850-141</b>
YZ250FP	2002	<b>850-131</b>	<b>850-141</b>
YZ250FR/FS/FT/FV	03-06	<b>850-131</b>	<b>850-142</b>
YZ250SPV	2006	<b>850-131</b>	<b>850-142</b>
YZ250N/S/T/U/W/WRW	85-89	<b>850-107</b>	_____
YZ250U/W	88-89	_____	<b>850-140</b>
YZ250A/B/D1/E1/F1/G1	90-95	_____	<b>850-140</b>
YZ250H1/J1/K1/L1/M1	96-00	_____	<b>850-141</b>
YZ250N1	2001	<b>850-130</b>	<b>850-141</b>
YZ250P	2002	<b>850-131</b>	<b>850-141</b>
YZ250R/S1/T1/V	03-06	<b>850-131</b>	<b>850-142</b>
YZ250WRW	1989	_____	<b>850-140</b>
YZ250WRA	1990	_____	<b>850-140</b>
TT350S/T	86-87	<b>850-107</b>	_____
XT350	85-00	<b>850-107</b>	_____
WR400FM	2000	_____	<b>850-141</b>
WR426FN	2001	<b>850-130</b>	<b>850-141</b>
WR426FP	2002	<b>850-131</b>	<b>850-141</b>
YZ426FM	2000	_____	<b>850-141</b>
YZ426FN	2001	<b>850-130</b>	<b>850-141</b>
YZ426FP	2002	<b>850-131</b>	<b>850-141</b>
WR450FR/FS/FT/FV	03-06	<b>850-131</b>	<b>850-142</b>
YZ450FR/FS/FT/FV	03-06	<b>850-131</b>	<b>850-142</b>
YZ450SPV	2006	<b>850-131</b>	<b>850-142</b>
YZ490A/N/S/T/U/W	85-89	<b>850-107</b>	_____
WR500ZD/ZE	92-93	_____	<b>850-140</b>
TT600N/S	85-86	<b>850-107</b>	_____
XT600L/LC-W/WC Dual Sport	84-89	<b>850-108</b>	_____
XT600EEC-EGC Dual Sport	90-95	<b>850-108</b>	_____

## Sudco Part Number to OEM Cross Reference Master Cylinder Rebuild Kits

### Honda

OEM Reference	Order No.
43520-KZ4-J41	850-121
43520-KZ4-J43	850-121
45520-MB2-305	850-122
43520-MB2-315	850-122
43520-MJ6-305	850-120
43520-MJ6-315	850-120
45530-377-305	850-103
45530-471-831	850-112
45530-HC5-006	850-114
45530-KCE-671	850-110
45530-KJ1-701	850-113
45530-KJ1-702	850-113
45530-KN5-305	850-111
45530-MN9-305	850-112
45530-MA4-671	850-102

### Kawasaki

43020-0016	850-181
43020-1056	850-170
43020-1063	850-171
43020-1094	850-171
43020-1112	850-180
43020-1123	850-181
43020-S004	850-150
43020-S006	850-110
43073-001	850-100

### Suzuki

59600-04810	850-150
59600-36830	850-153
59600-37810	850-152
59600-45850	850-151
69600-04810	850-160
69600-04820	850-120
69600-16820	850-160
K4302-00016	850-181
K4302-01123	850-181

### Yamaha

1FK-W0042-50-00	850-140
1J3-W0041-20-00	850-106
23L-W0041-00-00	850-108
29L-W0042-50-00	850-144
2KR-W0042-50-00	850-143
3GD-W0042-00-00	850-143
4GY-W0042-00-00	850-144
4H7-W0041-00-00	850-105
4H7-W0041-50-00	850-132
4K0-W0041-00-00	850-133
4K0-W0041-50-00	850-133
4SS-W0042-50-00	850-141
56A-W0041-00-00	850-107
5LP-W0041-00-00	850-134
5MV-W0041-00-00	850-130
5NY-W0041-00-00	850-131
5NY-W0041-01-00	850-131
5TG-W0042-50-00	850-145
5UN-W0042-50-00	850-142



### Motion Pro Master Cylinder Snap-Ring Pliers

Allows removal of internal snap rings used in hydraulic master cylinders. Replaces Honda# 07914-SA50001, can be used to remove and replace small to medium internal snap rings up to 50mm deep, including those used for transmission gear locating, bearing retention, and oil seal retention, applicable to some fork seal retaining rings.

Order No. **950-775**



# Master Cylinders



## Nissin Master Cylinders

Remote reservoir master cylinders from Nissin feature powerful stopping performance. Lever angle is adjustable to four different positions. Fits 7/8" handlebars. **Made in Japan.**

**Note:** Suzuki models need M10 x P1.25mm banjo bolt.

### Clutch, 5/8" Piston & Silver Body

Description	Order No.
Master Cylinder with 5/8" Piston & Silver Lever	<a href="#">850-001</a>
Master Cylinder Rebuild Kit with 5/8" Piston	<a href="#">850-020</a>
Master Cylinder Reservoir Tank & Hose	<a href="#">850-022</a>
Clutch Lever for Master Cylinder	<a href="#">850-023</a>

### Clutch, 14mm Piston & Silver Body

Description	Order No.
Master Cylinder with 14mm Piston & Silver Lever	<a href="#">850-002</a>
Master Cylinder Rebuild Kit with 14mm Piston	<a href="#">850-021</a>
Master Cylinder Reservoir Tank & Hose	<a href="#">850-022</a>
Clutch Lever for Master Cylinder	<a href="#">850-023</a>

### Brake, 5/8" Piston & Silver Body

Description	Order No.
Master Cylinder with 5/8" Piston & Silver Lever	<a href="#">850-010</a>
Master Cylinder Rebuild Kit with 5/8" Piston	<a href="#">850-030</a>
Master Cylinder Reservoir Tank & Hose	<a href="#">850-032</a>
Brake Lever for Master Cylinder	<a href="#">850-033</a>

### Brake, 14mm Piston & Silver Body

Description	Order No.
Master Cylinder with 14mm Piston & Silver Lever	<a href="#">850-011</a>
Master Cylinder Rebuild Kit with 14mm Piston	<a href="#">850-031</a>
Master Cylinder Reservoir Tank & Hose	<a href="#">850-032</a>
Brake Lever for Master Cylinder	<a href="#">850-033</a>

### Brake, 1/2" Piston, Silver Body & Short Lever

Description	Order No.
Master Cylinder with 1/2" Piston & Silver Lever	<a href="#">850-012</a>
Master Cylinder Rebuild Kit with 1/2" Piston	_____
Master Cylinder Reservoir Tank & Hose	<a href="#">850-032</a>
Brake Lever for Master Cylinder	_____

### Brake, 1/2" Piston, Black Body & Short Lever

Description	Order No.
Master Cylinder with 1/2" Piston & Black Lever	<a href="#">850-012B</a>
Master Cylinder Rebuild Kit with 1/2" Piston	_____
Master Cylinder Reservoir Tank & Hose	<a href="#">850-032</a>
Brake Lever for Master Cylinder	_____

## Nissin Radial Master Cylinders

The vertically angled body lets the lever flow fluid directly through the master cylinder giving it excellent braking response and powerful stopping performance. Lever is adjustable to six different positions. Fits 7/8" handlebars. **Made in Japan.**

**Note:** Use with M10 x P1.25mm banjo bolt.

### Brake, 17mm Piston & Black Body

Description	Order No.
Master Cylinder with 17mm Piston & Black Lever	<a href="#">850-016</a>
Master Cylinder Rebuild Kit with 17mm Piston	_____
Master Cylinder Reservoir Tank & Hose	<a href="#">850-032</a>
Brake Lever for Master Cylinder	_____

### Brake, 19mm Piston & Black Body

Description	Order No.
Master Cylinder with 19mm Piston & Silver Lever	<a href="#">850-015</a>
Master Cylinder Rebuild Kit with 19mm Piston	_____
Master Cylinder Reservoir Tank & Hose	<a href="#">850-032</a>
Brake Lever for Master Cylinder	_____

### Brake, 19mm Piston & Black Body

Description	Order No.
Master Cylinder with 19mm Piston & Black Lever	<a href="#">850-015B</a>
Master Cylinder Rebuild Kit with 19mm Piston	_____
Master Cylinder Reservoir Tank & Hose	<a href="#">850-032</a>
Brake Lever for Master Cylinder	_____

### Brake, 19mm Piston & Gold Body

Description	Order No.
Master Cylinder with 19mm Piston & Silver Lever	<a href="#">850-015G</a>
Master Cylinder Rebuild Kit with 19mm Piston	_____
Master Cylinder Reservoir Tank & Hose	<a href="#">850-032</a>
Brake Lever for Master Cylinder	_____



## Mityvac Brake Bleeding Kit

Flushes out brake fluid quickly and cleanly into reservoir container. Kit includes a repairable pump, reservoir container with transfer and storage lids, bleed adapters, plastic tubing and complete instructions.

**Order No. 850-060**



## Motion Pro Lever & Perch Assemblies

Available in black or polished for cable operated clutch and brake applications. Inexpensive replacement for Japanese OEM units. Split-perch design holder. Sold as an assembly - lever, lever holder (perch) and cable adjuster.

**Not for use with hydraulic brake or clutches.**

### Polished

Description	Order No.
Honda Clutch	628-302
Honda Front Brake Cable Type Brake	628-303
Kawasaki/Suzuki/Yamaha Clutch	628-306
Kawasaki/Suzuki/Yamaha Front Brake Cable Type Brake	628-307

### Black

Description	Order No.
Honda Clutch	628-300
Honda Front Brake Cable Type Brake	628-301
Kawasaki/Suzuki/Yamaha Clutch	628-304
Kawasaki/Suzuki/Yamaha Front Brake Cable Type Brake	628-305



## Sudco Banshee Carburetor Cable Kits

Fits stock thumb throttle. Sold as a kit for Yamaha YFZ350 Banshee. Two kits available.

### YFZ350 Banshee Carburetor Cable Kit without Idle Screws

Order No. 021-923

Includes 2 caps, 2 cable adjuster screws, 2 locknuts and throttle cable for stock thumb throttle.

### YFZ350 Banshee Carburetor Cable Kit with Idle Screws

Order No. 021-924

Includes 2 caps, 2 cable adjuster screws, 4 locknuts, throttle cable for stock thumb throttle and idle screws.

### Individual Replacement Parts

Description	Order No.
Cable Adjuster Screw with Locknut	021-273
Idle Adjuster Screw only	002-184
Idle Adjuster Screw Locknut only	002-065
Top Cap only VM34/27 (each)	002-066
Throttle Cable for stock Thumb Throttle	021-278



## Quick Adjust MX Clutch Lever

Fits all 7/8" handlebars. Features quality 6061-T6 forged aluminum, Quick-adjuster for on-the-fly adjustments, CR ratio, Includes black rubber mud cover. Sold as an assembly - lever, lever holder (perch) and quick cable adjuster.

Order No. 628-313



021-921



021-922

## Sudco Blaster/Banshee Carburetor Caps

Sold as kits for Yamaha YFS200 Blaster, and YFZ350 Banshee.

YFZ350 Banshee Kit

Order No. 021-921

Includes 2 caps, 2 cable adjuster screws and 2 locknuts.

YFZ200 Blaster Kit

Order No. 021-922

Includes 1 cap, 1 cable adjuster screw and 1 locknut.

### Individual Replacement Parts

Description	Order No.
Cable Adjuster Screw with Locknut	021-273
Top Cap only VM34/27 (each)	002-066



## Quick Adjust MX Clutch Lever with Hot Start Lever

Fits all 7/8" handlebars. Features quality 6061-T6 forged aluminum, roller bearing in pivot for effortless operation and quick cable adjuster for on-the-fly adjustments. CR ratio. Nylon mounting sleeve rotates on impact to protect lever. Sold as an assembly - lever, lever holder (perch) and quick cable adjuster.

Order No. 628-311



## Motion Pro Honda CRF/XR50 Control Kit

This kit is designed for use with most high rise bar kits. Intended for use with stock carburetor. Includes the following: CR Pro Throttle, Throttle Cable with Carb Cap, Brake Lever with Perch Assembly and Brake Cable.

Order No. 021-953

# Throttles



## Motion Pro Straight Push-Pull Throttle

Die-cast aluminum housing with black epoxy finish. This throttle is similar to Yamaha YZ/WR400, FZR, YZF and XT dual-sport bikes.

Order No. [021-280](#)

## Motion Pro Turbo Throttle

Polished die-cast aluminum housing. Opens 28-38mm carburetors. Perfect ratio for off-road motorcycles or ATV's. Comes with cable adjuster and dust boot.

Order No. [021-274](#)



## Motion Pro CR Pro Throttle

Made from die cast aluminum with a black epoxy finish. Opens 30-34mm carburetors. Throttle cable will clear brake master cylinder on handlebar. Early disk-brake Honda CR replacement. Includes throttle sleeve with grip retaining ring and pop out end.

Order No. [021-966](#)

## Motion Pro Vortex Throttle

Made from die cast aluminum with a gray finish and gray rubber mud cover. Similar to most OEM late model Japanese MX/off road bikes.

Description	Order No.
Vortex Throttle. Fits Kaw KX125/250 (92-03), Suz RM125/250 (95-04) & Yam YZ125/250 (96-04)	<a href="#">021-951</a>
Replacement Sleeve for Vortex Throttle.	<a href="#">021-952</a>



## Magura 314 Straight Pull Throttle

Reinforced polycarbonate housing with a black finish. Adjustable turn ratio from MX to Enduro in minutes. Includes protective rubber cable boot. Ideal for MX/off road bikes or ATV's.

Order No. [005-225](#)

## Motion Pro Push/Pull Throttle Assembly

Die-cast aluminum housing with black epoxy finish. Use with Mikuni smooth-bore conversions on street and race bikes. Includes push/pull twist throttle and both cables with adjusters.

Order No. [005-230](#)

### Replacement Parts for 005-230 Push/Pull Throttle Assembly

Description	Order No.
Pull Throttle Cable only for Mikuni Smooth Bore	<a href="#">005-230A</a>
Push Throttle Cable only for Mikuni Smooth Bore	<a href="#">005-230B</a>
Push/Pull Twist Throttle only	<a href="#">005-230C</a>
Throttle Tube only	<a href="#">005-230D</a>





## Motion Pro ATV Twist Throttle Kit

### Description

Throttle Kit for Yamaha YFZ450 (2004)  
Kit includes Vortex throttle, and cable.

### Order No.

**021-950**

Throttle Kit for Yamaha YFZ350 Banshee.

**021-270**

Kit includes Turbo throttle, and 2-into-1 cable.

Replacement 2-into-1 Throttle Cable for **021-270**

**021-270A**

## Pedal Anchor Kit

Prevents brake pedal from catching on berms, branches, rocks, etc., includes 3 cables, 3 special crimp fittings and 12 in. of 1/8 in. clear PVC

### Order No.

**950-777**

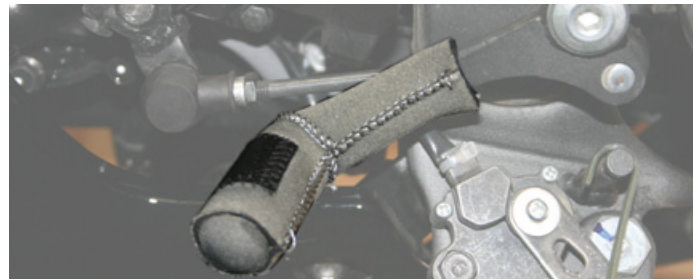

## PC Racing Shifter Skins

The PC Racing Shifterskin protects your shoes from ugly shifter marks

- Made from durable, washable neoprene
- Shifterskin provides easier shifting
- Fits most bikes
- Slides on in seconds

### Color

Black PCSSBLACK  
Gray PCSSGREY

### Order No.

**945-120**  
**945-121**



## Cycle Pirates Diamond Chrome Emblems

These diamond-chrome emblems are made for the "Show King" in all of us. Put them on your bike, wall or where ever you want. Made with automotive grade weather resistant adhesive, chromed and diamond studded. These emblems are sure to bling. Sold each.

### Honda

Model	Letter	C.P. Part No	Order No.
CBR600RR	600RR	ED600RR	<b>946-402</b>
CBR1000RR	1000RR	ED1000RR	<b>946-405</b>

### Kawasaki

ZX-6R	ZX6R	EDZX6R	<b>946-460</b>
ZX-10R	ZX10R	EDZX10R	<b>946-462</b>
ZX1400	ZX1400	EDZX1400	<b>946-464</b>

### Suzuki

Hayabusa	GSX1300R	EDGSX1300R	<b>946-422</b>
1000	1000	ED1000	<b>946-426</b>

### Yamaha

R1	R1	EDR1	<b>946-440</b>
R6	R6	EDR6	<b>946-442</b>



# Control Cables



## Motion Pro ATV Terminator Clutch Cables

Replacement clutch cables for ATV applications. Sold each.

### Honda

Model	Year	M.P. Ref.	Order No.
ATC250R	81-84	02-0208	<b>655-050</b>
ATC250R	85-86	02-0207	<b>655-051</b>
TRX250R Fourtrax 250R	86-89	02-0208	<b>655-050</b>
TRX400EX Fourtrax 400EX	99-00	02-0392	<b>655-055</b>
TRX400EX Sportrax 400EX	01-05	02-0392	<b>655-055</b>

### Kawasaki

KSF400A1/A2/A3 KFX400	03-05	04-0229	<b>655-645</b>
-----------------------	-------	---------	----------------

### Suzuki

LT230SF/SG/SH/SJ Quad	85-88	04-0101	<b>655-420</b>
LT250RF-RN Quadracer	85-92	04-0102	<b>655-422</b>
LT250SK/SL Quadracer	89-90	04-0101	<b>655-420</b>
LT-Z400K3/K4/K5 Quadracer	03-05	04-0229	<b>655-645</b>
LT500R Quadracer	87-90	04-0108	<b>655-421</b>

### Yamaha

YFS200 Blaster	88-05	05-0187	<b>655-211</b>
YFM350X Warrior	87-04	05-0117	<b>655-212</b>
YFZ350 Banshee	87-05	05-0116	<b>655-210</b>
YFZ450R	04-05	05-0312	<b>655-213</b>
YFM660 Raptor	02-05	05-0272	<b>655-214</b>



## Brake Light Switch (Hydraulic)

Universal hydraulic brake light switch. Use with high performance master cylinder without integral brake light switch. (10 x 1.25mm PITCH)

Order No. **950-275**

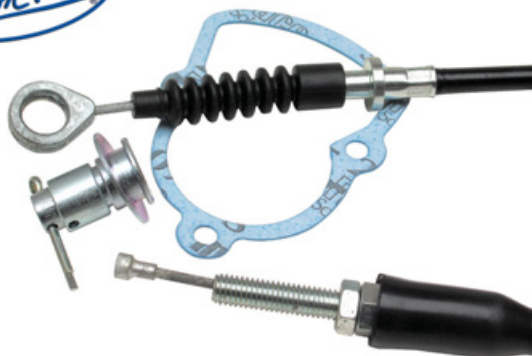

## Rear Brake Kit for Yamaha Blaster

Fits Yamaha YFS200 Blaster from 1988-2006. Eliminates the stock cable from the handlebar. Cable mounts from the rear brake pedal to the caliper.

Order No. **604-670**



## Motion Pro Cable Luber

Use to inject lubricant into cable housing. Clamps over cable housing allowing an aerosol can tip to be connected for injection inside. Once the lubricant runs out of far end, the cable is lubricated. Sold each.

Order No. **950-447**



## PJ1 Cable Lube

Cleans, lubricates and extends cable life. Makes cable pull easier. Sold in 11 fl.oz aerosol can..

Order No. **899-190**

## Motion Pro ATV & Offroad Throttle Cables

Replacement throttle cables for carburetor and applications listed.  
Sold each.



### ATV's & Dirtbikes

	Throttle	Carburetor	Notes	Order No.
ATV's & Dirtbikes	M.P. Turbo	Mikuni TM28-34, Keihin PJ34-38, PWK28-39	Single Carb 41	021-277
ATV's & Dirtbikes	M.P. Turbo	Mikuni VM30-38, TM36-38, TMS Keihin PE36-38	Single Carb 40.5	021-276
ATV's & Dirtbikes	Magura Duo	Mikuni VM30-38, TM32-38, TMX, TMS38 Keihin PJ, PWK	Single Carb 50	657-902B

### Honda

ATC250R (85-86)	Stock Thumb	Mikuni TM36-38, Keihin PJ36-38, PWK35-39	Single Carb 45° elbow at carb	021-910
TRX250R 86-89	M.P. Turbo	Mikuni TM36-38, TMX35-38, VM30-38 Keihin PE35-38	Single Carb 45° elbow at carb	021-911
ATC250R (81-86)	M.P. Turbo	Mikuni TM28-34, Keihin PJ34-38, PWK28-39	Single Carb 45° elbow at carb	021-912

### Suzuki

LT250R, LT500R	Stock Thumb	Keihin PJ34-38, PWK35-39	Single Carb	021-915
	M.P. Turbo	Keihin PJ34-38, PWK35-39, Mikuni TM28-34	Single Carb 45° elbow at carb	021-912
	M.P. Turbo	Mikuni VM32-38, TM36-38, TMX35-38 TMS38	Single Carb 45° elbow at carb	021-911

### Yamaha

YFS200 Blaster	M.P. Turbo	Stock, Mikuni TM28-34, Keihin PJ34,	Single Carb 47.75	021-277
	Stock Thumb	Stock, Mikuni TM28-34, Keihin PJ34, PWK28-35	Single Carb 41	021-279
YFM350X Warrior		Stock, Mikuni VM30-34		021-949
YFZ350 Banshee	M.P. Turbo	Stock, Mikuni TM28-34, Keihin PJ34, PWK28-35	2 into 1	021-275
YFZ350 Banshee	Stock Thumb	Stock, Mikuni TM28-34, Mikuni VM30-34	2 into 1 2 into 1	021-278 021-270A
		Keihin PJ34, PWK28-35 Mikuni VM30-34		021-955
YXR660 Rhino	Stock	Keihin FCR Mikuni HSR	Single Single	021-963 021-964

## Motion Pro Vintage Street Throttle Cables

Replacement throttle cables for carburetor and applications listed.  
Sold each.



### Ducati

Model	Throttle	Carburetor	Notes	Order No.
	Stock	Mikuni TM38		021-907
	Stock	Mikuni TM38	Choke Cable for TM38	021-906

### Enfield

500	Stock	Mikuni VM34		021-947
-----	-------	-------------	--	---------

### Harley-Davidson®

	Stock	Mikuni VM36-38, TM36-41		657-900
	Stock	Mikuni VM36-38, TM36-41	90° at carb	657-901

### Norton

	Stock	Mikuni VM34 single	MK34/39	007-575
	Stock	Mikuni VM36-38	MK36/39	007-576
	Stock	Mikuni Dual VM32-34	2-into-1	002-025
	M.P. YZF style	Keihin Dual 35H FCR	Push/Pull	021-940

### Triumph

TR6/TR7	Stock	Mikuni VM30-34	MK32/43	007-577
T120/T140	Stock	Mikuni VM30-34	MK32/18 (2 cables required, carb to junction box only)	007-578

### Yamaha

RD350 (73-75)	M.P. Turbo	Mikuni TM32-41, VM34-38,	2 into 1, some soldering is required	002-025
RZ350 (84-85)		Keihin PJ34-38, PWK28-39		

# Folding Brake Levers & Shift Levers



## Cycle Pirates Folding Brake Levers

Designed to replace the stock levers with a functional and custom alternative. Made from 6061 forged aluminum featuring a solid CNC-machined knurled tip that folds to reduce damage upon impact. Available in polished or anodized colors.

### Honda

Model	Year	Black	Gold	Blue	Red	Silver
CBR600F4	99-00	---	---	---	---	946-100S
CBR600F4I	01-06	---	---	---	---	946-100S
CBR600RR	03-06	---	---	---	---	946-102S

### Kawasaki

ZX636 ZX-6R	03-04	946-160K	---	---	---	---
-------------	-------	----------	-----	-----	-----	-----

### Suzuki

GSX-R600	01-05	---	---	946-140B	---	---
GSX-R600	06-07	---	---	---	---	946-141S
GSX-R750	01-05	---	---	946-140B	---	---
GSX-R750	06-07	---	---	---	---	946-141S
GSX1300R	99-07	946-145K	946-145G	---	---	946-145S

### Yamaha

YZF-R6	99-02	---	---	946-120B	946-120R	946-120S
YZF-R6	03-06	---	---	946-121B	946-121R	946-121S
YZF-R1	02-03	---	---	946-125B	946-125R	946-125S
YZF-R1	04-06	---	---	946-126B	946-126R	---



## Cycle Pirates Folding Shift Levers

Designed to replace the stock levers with a functional and custom alternative. Made from 6061 forged aluminum featuring a solid CNC-machined knurled tip that folds to reduce damage upon impact. Available in polished or anodized colors.

### Suzuki

Model	Year	Black	Gold	Blue	Red	Silver
*GSX-R600 (*non folding)	2006	---	---	---	---	946-041S*
*GSX-R750 (*non folding)	2006	---	---	---	---	946-041S*
GSX1300R Hayabusa	99-07	946-045K	946-045G	---	---	---

### Yamaha

YZF-R6	99-06	---	---	946-020B	946-020R	---
YZF-R1	02-07	---	---	946-022B	---	---



## Cycle Pirates Mirror Block-Offs

Made from aircraft-grade machined aluminum. These mirror block-offs come triple-chromed or in a variety of anodized colors with trademark tribal design. This a perfect accessory for the sport bike enthusiast who wants to stand out. Sold each.

### Honda

Model	Year	Black	Gold	Blue	Red	Green	Chrome
CBR600F4		946-200K	946-200G	946-200B	946-200R	---	---
CBR600F4i		946-200K	946-200G	946-200B	946-200R	---	---
CBR600RR	04-06	946-200K	946-200G	946-200B	946-200R	---	---
VFR800		946-200K	946-200G	946-200B	946-200R	---	---
CBR900RR		946-200K	946-200G	946-200B	946-200R	---	---
CBR929RR		946-200K	946-200G	946-200B	946-200R	---	---
CBR954RR		946-200K	946-200G	946-200B	946-200R	---	---
CBR1000RR	04-06	946-200K	946-200G	946-200B	946-200R	---	---

### Kawasaki

ZX636 ZX-6	05-07	946-260K	946-260G	946-260B	---	946-260GR	---
ZX1000 ZX-10R	05-07	946-260K	946-260G	946-260B	---	946-260GR	---

### Suzuki

GSX-R600	01-05	946-240K	---	946-240B	---	---	---
GSX-R750	01-05	946-240K	---	946-240B	---	---	---
GSX-R1000	01-05	946-240K	---	946-240B	---	---	---
GSX1300R Hayabusa	99-07	946-245K	---	946-245B	---	---	946-245C

### Yamaha

YZF-R6	99-06	---	---	---	946-220R	---	---
YZF-R1	99-06	---	---	---	946-220R	---	---

## Cycle Pirates Headlight Trim

Headlight trim is a thin aluminum spined adhesive and finished in chrome or mirror black. Coated with a soft weather resistant resin to stay flexible and backed with a 3M adhesive. Designed to fit the contour of your headlight while giving your cycle an aggressive custom look. Sold each.

### Honda

Model	Year	Black	Chrome
CBR600RR	03-06	946-300K	---
CBR1000RR	04-06	946-300K	---

### Suzuki

GSX-R600	06-07	946-340K	946-340C
GSX-R750	06-07	946-340K	946-340C
GSX1300R	99-07	946-345K	946-345C

### Yamaha

YZF-R1	04-06	946-320K	946-320C
--------	-------	----------	----------



946-320C

# Brake Pads & Brake Shoes

VINTAGE  
INTAKE  
ENGINE  
SUSPENSION  
CONTROL  
ELECTRICAL  
CHEMICAL  
TOOLS  
WATERCRAFT



## How to order Vesrah Brakes from Sudco

**Brake Pads:** All pads have a "610" prefix.

### Brake Pad Compounds:

Kevlar/Carbon Pads have a simple 3 digit suffix "610-134".  
Sintered Metal Pads have a "JL" after the 3 digit suffix "610-134JL".

### Compound Specification:

**Kevlar/Carbon** - Since the elimination of asbestos in the Vesrah product line, Kevlar has been the standard brake pad material since 1990. Kevlar/Carbon pads are very temperature stable and have a high coefficient of friction for sure footed braking under all conditions, and are stainless steel rotor safe.

**Sintered Metal** - The sintered Metal "JL" pads from Vesrah feature the latest generation of high performance friction materials. Sintered metal pads are a mixture of copper, tin, graphite and other materials resulting in a brake pad with very high performance characteristics, especially in wet conditions. Sintered pads are stainless steel rotor compatible.

**Brake Shoes:** All shoes have a "611" prefix.

### Brake Shoe Compounds:

Standard Kevlar / Carbon Shoes have a simple 3 digit suffix "611-150"  
Grooved shoes have an "NS" after the 3 digit suffix "611-150NS".

### Compound Specifications:

Grooved brake shoes offer more consistent performance in wet conditions and higher friction levels for motocross and offroad racing than with standard shoes.



## Honda Street

Model	Year	Kevlar		Sintered	
		Qt Front	Rear	Qt Front	Rear
CHF50 Metropolitan	02-11	1 611-150	611-150	1 611-150NS	611-150NS
MB5-50	1982	1 610-120	611-126	1	611-126NS
NA50 Express II	79-81	1 611-134	611-141	1	
NB50 Aero 50	86-87	1 611-134	611-141	1	
NB50M Aero 50	83-85	1 611-134	611-141	1	
NC50 Express	77-80	1 611-134	611-134	1	
NC50 Express	81-83	1 611-134	611-141	1	
NN50MD Gyro	1984	1 611-134	611-134	1	
NQ50 Spree	84-87	1 611-134	611-134	1	
NQ50D Spree Special	1986	1 611-134	611-134	1	
NS50F	1990	1 611-101	611-126	1	611-126NS
NU50 Urban Express	82-83	1 611-150	611-141	1 611-150NS	
NU50M Deluxe	82-83	1 611-150	611-141	1 611-150NS	
NX50M Express SR	81-82	1 611-134	611-141	1	
P50	67-68	1 611-134		1	
PA50	78-79	1 611-134	611-134	1	
PA50II Moped	78-83	1 611-134	611-134	1	
SA50 Elite 50 LX	88-93	1 611-134	611-141	1	
SB50 Elite 50 ES	1988	1 611-134	611-134	1	
SB50P Elite 50 E	88-90	1 611-134	611-134	1	
SE50 Elite 50 S	1987	1 611-134	611-141	1	
SE50P Elite 50	1987	1 611-134	611-141	1	
TG50 Gyro S	1986	1 611-134	611-134	1	
TG50M Gyro S	1985	1 611-134	611-134	1	
C70 Passport	80-83	1 611-101	611-101	1	
CT0K1 Honda 70	72-73	1 611-101	611-101	1	
CL70/K1-K3 Scrambler	69-73	1 611-101	611-101	1	
CT70	91-94	1 611-101	611-101	1	
CT70 Trail 70	69-71	1 611-101	611-101	1	
CT70 Trail 70	76-82	1 611-101	611-101	1	
CT70H/HK1 Trail 70H	70-73	1 611-101	611-101	1	
CT70K1-K4 Trail 70	72-75	1 611-101	611-101	1	
XL70/K1	74-75	1 611-101	611-101	1	
XL70	76-78	1 611-101	611-101	1	
XL75	77-79	1 611-126	611-126	1 611-126NS	611-126NS
CH80 Elite 80	85-07	1 611-101	611-150	1	611-150NS
NH80MD Aero 80	83-84	1 611-101	611-141	1	
NH80 Aero 80	1985	1 611-101	611-141	1	
XL80S	80-85	1 611-126	611-126	1 611-126NS	611-126NS
CT90K1-K4 Trail 90	69-73	1 611-101	611-101	1	
CT90K5/K6 Trail 90	74-75	1 611-101	611-126	1	611-126NS
CT90 Trail 90	76-79	1 611-101	611-126	1	611-126NS
EZ90 Cub	91-96	1 611-101	611-101	1	
SL90 Motosport 90	1969	1 611-101	611-101	1	
ST90K0/K1/K2	73-75	1 611-101	611-101	1	
SL100K0/K1/K2	70-73	1 611-101	611-126	1	611-126NS
XL100K0/K1	74-75	1 611-126	611-126	1 611-126NS	611-126NS
XL100	1976	1 611-126	611-126	1 611-126NS	611-126NS
XL100	77-78	1 611-101	611-126	1	611-126NS
XL100S	79-85	1 611-126	611-126	1 611-126NS	611-126NS
CB125S	1973	1 611-101	611-101	1	
CB125S1/S2	74-75	1 610-109	611-126	1	611-126NS
CB125S	1976	1 610-109	611-126	1 610-109NR	611-126NS
CB125S	1978	1 610-109	611-126	1	611-126NS
CB125S	79-82	1 611-126	611-126	1 611-126NS	611-126NS
CB125S	84-85	1 611-126	611-126	1 611-126NS	611-126NS
CB125TT	1990	1 610-143/2	611-130	1 610-143/2J	
CH125 Elite 125	1984	1 611-101	611-101	1	
CL125S Scrambler	1973	1 611-101	611-101	1	
CL125S Scrambler	1974	1 610-109	611-126	1	611-126NS
CT125 Trail 125	1977	1 611-126	611-126	1 611-126NS	611-126NS
MT125K0/K1 Elsinore	74-75	1 611-126	611-126	1 611-126NS	611-126NS
MT125 Elsinore	1976	1 611-126	611-126	1 611-126NS	611-126NS
NH125 Aero 125	1984	1 611-101	611-101	1	
NX125	88-90	1 611-142	611-126	1	611-126NS
SL125K0/K1/K2	71-73	1 611-101	611-126	1	611-126NS
XL125K0/K1	74-75	1 611-126	611-126	1 611-126NS	611-126NS
XL125	1976	1 611-126	611-126	1 611-126NS	611-126NS
XL125	77-78	1 611-101	611-126	1	611-126NS
XL125S	79-82	1 611-126	611-126	1 611-126NS	611-126NS

## Honda Street

Model	Year	Kevlar		Sintered	
		Qt Front	Rear	Qt Front	Rear
XL125S	1984	1 611-126	611-126	1 611-126NS	611-126NS
XL125S	1985	1	611-126	1	611-126NS
CH150 Elite 150	1985	1 611-101	611-101	1	
CH150 Elite 150	1987	1 611-101	611-101	1	
CH150D Deluxe	85-86	1 611-101	611-101	1	
CB175K3-K7	69-73	1 610-110	611-139	1	
CL175K0/K3-K7	68-73	1 610-110	611-139	1	
SL175K0/K1	70-72	1 611-139	611-139	1	
XL175K0/K1/K2	73-75	1 611-125	611-130	1	
XL175	76-78	1 611-125	611-130	1	
CM185T Twinstar	78-79	1 611-125	611-130	1	
XL185S	79-83	1 611-126	611-126	1 611-126NS	611-126NS
CB200K0	1974	1 610-110	611-139	1	
CB200T	75-76	1 610-110	611-139	1	
CL200 Scrambler	1974	1 610-110	611-139	1	
CM200T Twinstar	80-82	1 611-125	611-130	1	
TLR200 Reflex	86-87	1 611-126	611-126	1 611-126NS	611-126NS
TR200 Fatcat	86-87	1 611-126	611-126	1 611-126NS	611-126NS
XL200R Dual Sport	83-84	1 611-126	611-126	1 611-126NS	611-126NS
CB250 Nighthawk	91-07	1 611-125	611-130	1	
CH250 Elite 250	85-86	1		1	
CH250 Elite 250	87-88	1	611-142	1	
CH250 Elite 250	89-90	1 611-142	611-142	1	
CM250C Custom	82-83	1 611-125	611-130	1	
CMX250C Rebel	85-87	1 610-131	611-130	1	
CMX250C Rebel	96-04	1 VD-3402JL	611-136	1	
CMX250C Rebel	05-12	1 VD-3402JL	611-136	1	
CMX250CD Rebel	1986	1 610-131	611-130	1	
CN250 Helix	86-87	1 610-123	611-142	1 610-123J	
CN250 Helix	92-93	1 610-123	611-142	1 610-123J	
CN250 Helix	94-01	1 610-156/3	611-142	1	
CN250 Helix	04-07	1 610-156/3		1	
NSS250 (Scooter)	01-06	1 610-165/2		1 610-165/2J	
NSS250A (Scooter)	01-06	1 610-165/2		1 610-165/2J	
NX250	88-89	1 610-139	611-140	1 610-139J	611-140NS
NX250	1990	1 610-161	611-140	1	611-140NS
VTR250 Interceptor	88-89	1	611-139	1	
VTR250 Interceptor	1990	1 610-142	611-139	1 610-142J	
VTR250	98-11	1 610-156/3	VD-147JL		
XL250K0 Motosport	72-73	1 611-124	611-125	1	
XL250K1/K2	74-75	1 611-124	611-125	1	
XL250	1976	1 611-124	611-125	1	
XR250L Dual Sport	91-96	1 610-161	610-144	1	
CB350F/F1 Super Sport	72-74	1 610-102	611-127	1	
4-cylinder					
CB350G Super Sport	1973	1 610-102	611-127	1	
2-cylinder					
CB350K0-K4 (2-cyl)	68-73	1 611-119	611-127	1	
CL350K0/K1-K5	68-73	1 611-119	611-127	1	
SL350K0	1970	1 611-119	611-127	1	
SL350K1/K2	71-72	1	611-139	1	
XL350K0/K1	74-75	1 611-124	611-125	1	
XL350	76-78	1 611-124	611-125	1	
XL350R	84-85	1 610-134	611-140	1 610-134J	611-140NS
CB360	1974	1 610-102	611-127	1	
CB360G	1974	1 610-102	611-127	1	
CB360T	75-76	1 610-102	611-127	1	
CJ360T	76-77	1 611-119	611-127	1	
CL360K0 Scrambler	1974	1 611-119	611-127	1	
CB400A Automatic	1978	1 610-117	611-132	1	
CB400F CB-1	89-90	1 610-156/2		1 610-156/2J	
CB400F Super Sport	75-77	1 610-102	611-127	1	
CB400T Hawk	80-81	1 610-123/2	611-132	1	
CB400TI Hawk I	78-79	1 611-119	611-132	1	
CB400TII Hawk II	78-79	1 610-117	611-132	1	
CM400A Automatic	79-81	1 610-117	611-132	1	
CM400C Custom	1981	1 610-123/2	611-132	1	
CM400E	80-81	1 611-119	611-132	1	
CM400T	79-81	1 610-117	611-132	1	
CB450SC Nighthawk	82-85	1 610-130	611-132	1	

# Brake Pads & Brake Shoes

## Honda Street

Model	Year	Kevlar		Sintered	
		Front	Rear	Front	Rear
CB450SC Nighthawk	1986	1	610-123/2611-132	1	_____
CB450T Hawk	1982	1	610-130 611-132	1	_____
CM450A Automatic	82-83	1	610-130 611-132	1	_____
CM450C Custom	1982	1	610-130 611-132	1	_____
CM450E	82-83	1	611-119 611-132	1	_____
CMX450C Rebel	86-87	1	610-123 611-132	1	610-123J _____
CB500K0/K1/K2	71-73	1	610-102 611-128	1	_____
CB500T	75-76	1	610-102 611-128	1	_____
CX500	78-79	1	610-112/2611-133	1	_____
CX500C Custom	79-80	1	610-112/2611-133	1	_____
CX500C Custom	1981	1	610-112 611-133	1	610-112J _____
CX500C Custom	1982	1	610-123 611-133	1	610-123J _____
CX500D Deluxe	79-80	1	610-112/2611-133	1	_____
CX500D Deluxe	1981	1	610-112 611-133	1	610-112J _____
CX500TC Turbo	1982	2	610-123 610-123	2	610-123J 610-123J
FT500 Ascot	82-83	1	610-123 610-123	1	610-123J 610-123J
GB500	89-90	1	610-123/3	1	_____
GL500 Silver Wing	81-82	2	610-123 611-133	2	610-123J _____
GL500I Interstate	81-82	2	610-123/2611-133	2	_____
VF500C V30 Magna	84-85	1	610-123 611-133	1	610-123J _____
VF500F Interceptor	84-86	2	610-123/2610-123	2	_____ 610-123J
VT500C Shadow	83-86	1	610-123 611-133	1	610-123J _____
VT500FT Ascot	83-84	1	610-123 611-132	1	610-123J _____
XL500R Dual Sport	1982	1	611-148 611-136	1	_____
XL500R Dual Sport	83-84	1	610-134 611-136	1	610-134J _____
XL500S Dual Sport	79-80	1	611-125 611-136	1	_____
XL500S Dual Sport	1981	1	611-138 611-139	1	_____
CB550F Super Sport	75-77	1	610-102 611-128	1	_____
CB550/K1	74-75	1	610-102 611-128	1	_____
CB550K	76-78	1	610-102 611-128	1	_____
CB550SC Nighthawk	1983	1	610-123 611-132	1	610-123J _____
CB600F (599)	2004	2	610-156 610-163	2	_____
CB600F (599)	00-06	2	610-156 610-163	2	_____
CB600F (599)	07-11	2	610-156 VD-174JL	2	_____
CBR600F Hurricane	87-90	2	610-142 610-123/3	2	_____
CBR600F2 Hurricane	91-94	2	610-142 610-163	2	_____
CBR600F3 Hurricane	95-98	2	610-156 610-163	2	_____
CBR600F4 Hurricane	99-00	2	610-166 610-163	2	_____
CBR600F4i Hurricane	01-06	2	610-166/2610-163	2	_____
CBR600FR Rossi	2002	2	610-166/2610-163	2	_____
CBR600RR	03-04	2	610-166/2610-163	2	_____
CBR600RR	05-06	2	VD-170 610-163	2	_____
CBR600RR	07-11	2	VD-170 VD-174	2	SD-170 SD-174
CBR600SE	1998	2	610-156 610-163	2	_____
CBR600SJR Replica	1996	2	610-156 610-163	2	_____
FSC600 Silver Wing	02-07	1	610-165/3610-156	1	_____
FSC600A Silver Wing	03-11	1	610-165/3610-156	1	_____
FSC600D Silver Wing	03-09	1	610-165/3610-156	1	_____
VT600C Shadow VLX	88-89	1	610-143/2611-133	1	610-143/2J _____
VT600C Shadow VLX	88-89	1	610-143/2611-133N	1	610-143/2J _____
VT600C Shadow VLX	91-93	1	610-143/2611-133	1	610-143/2J _____
VT600C Shadow VLX	94-03	1	610-156/3611-133	1	_____
VT600C Shadow VLX	04-07	1	610-156/3611-157	1	_____
VT600CD VLX Deluxe	1993	1	610-143/2611-133	1	610-143/2J _____
VT600CD VLX Deluxe	1994	1	610-143/2610-156/3	1	610-143/2J _____
VT600CD VLX Deluxe	95-03	1	610-156/3611-133	1	_____
VT600CD VLX Deluxe	04-07	1	610-156/3611-157	1	_____
VT600CD2 VLX Deluxe	99-00	1	610-156/3611-133	1	_____
XL600R Dual Sport	83-87	1	610-134 611-136	1	610-134J _____
XL600V Transalp	89-90	1	610-123 611-136	1	610-123J _____
CB650	79-81	1	610-117 611-129	1	_____ 611-129NS
CB650	1982	1	610-123 611-129	1	610-123J 611-129NS
CB650C Custom	80-81	1	610-117 611-129	1	_____ 611-129NS
CB650SC Nighthawk	1982	2	610-130 611-129	2	_____ 611-129NS
CB650SC Nighthawk	83-85	2	610-123/2611-133	2	_____
CX650C Custom	1983	1	610-123 611-133	1	610-123J _____
CX650T Turbo	1983	2	610-123/2610-123	2	_____
GL650 Silverwing	1983	2	610-123/2611-133	2	_____
GL650I Interstate	1983	2	610-123/2611-133	2	_____
NT650 Hawk GT	88-91	1	610-156/2	1	610-156/2J _____

## Honda Street

Model	Year	Kevlar		Sintered	
		Front	Rear	Front	Rear
NX650	88-89	1	610-143/2611-136	1	610-143/2J _____
XR650L Dual Sport	93-12	1	610-161 610-144	1	_____
CB700SC Nighthawk	84-86	2	610-123 611-146	2	_____
VF700C Magna	1984	2	610-123 611-133	2	610-123J _____
VF700C Magna	85-86	2	610-123 611-146	2	610-123J _____
VF700C Magna	1987	2	610-123/3611-146	2	_____
VF700F Interceptor	84-85	2	610-123 610-123/3	2	610-123J _____
VF700S Sabre	84-85	2	610-123 611-133	2	610-123J _____
VFR700F/F2	86-87	2	610-143 610-123/3	2	_____
Interceptor					
VT700C Shadow	84-85	2	610-130 611-133	2	_____
VT700C Shadow	86-87	2	610-123 611-146	2	610-123J _____
CB750 Nighthawk 750	91-93	1	610-156/3611-133	1	_____
CB750 Nighthawk 750	91-93	1	610-156/3611-133N	1	_____
CB750A Automatic	76-78	1	610-102 611-129	1	_____ 611-129NS
CB750C Custom	80-81	2	610-117 611-129	2	_____ 611-129NS
CB750C Custom	1982	2	610-123/2611-129	2	_____ 611-129NS
CB750F Super Sport	75-76	1	610-102 610-108	1	_____
CB750F Super Sport	77-79	2	610-112 610-112	2	610-112J 610-112J
CB750F Super Sport	1980	2	610-112/2610-112/2	2	_____
CB750F Super Sport	81-82	2	610-123/2610-123	2	_____ 610-123J
CB750K0/K1-K5	69-75	1	610-101 611-129	1	_____ 611-129NS
CB750K	1976	1	610-101 611-129	1	_____ 611-129NS
CB750K	77-78	1	610-102 611-129	1	_____ 611-129NS
CB750K	79-81	1	610-117 611-129	1	_____ 611-129NS
CB750K	1982	1	610-123 611-129	1	610-123J 611-129NS
CB750L LTD	1979	1	610-117 611-129	1	_____ 611-129NS
CB750SC Nighthawk	82-83	2	610-123/2611-129	2	_____ 611-129NS
RVF750R (RC45)	1994	2	610-154	2	_____
VF750C V45 Magna	82-83	2	610-123 611-133	2	610-123J _____
VF750C V45 Magna	1988	1	610-123 611-146	1	610-123J _____
VF750C Magna	94-03	1	610-156/2611-146	1	610-156/2J _____
VF750C2 Deluxe	97-03	1	610-156/2611-146	1	610-156/2J _____
VF750CD Magna	95-03	1	610-156/2611-146	1	610-156/2J _____
VF750F Interceptor	83-84	2	610-123 610-123/3	2	610-123J _____
VF750S Sabre	82-83	2	610-123 611-133	2	610-123J _____
VF750S Sabre	82-83	2	610-123 611-133N	2	610-123J _____
VFR750F Interceptor	1986	2	610-123/3610-123/3	2	_____
VFR750F	90-97	2	610-156 610-156/2	2	_____ 610-156/2J
VFR750R (RC30)	1990	2	610-154	2	610-154J _____
VT750C Shadow	1983	2	610-130 611-133	2	_____
VT750C Shadow A.C.E	98-02	1	610-156/2611-146	1	610-156/2J _____
VT750C Shadow Aero	04-07	1	610-156/2611-146	1	610-156/2J _____
VT750 Shadow Aero	08-11	1	610-156/2611-146	1	610-156/2J _____
VT750C2F Shadow Spirit	10-11	1	610-156/2611-146	1	610-156/2J _____
VT750CA Shadow Aero	04-10	1	610-156/2611-146	1	610-156/2J _____
VT750CD Deluxe	98-02	1	610-156/2611-146	1	610-156/2J _____
VT750CD2 Deluxe	98-02	1	610-156/2611-146	1	610-156/2J _____
VT750CDA Shadow	02-03	1	610-156/2611-146	1	610-156/2J _____
VT750CDB Shadow	02-03	1	610-156/2611-146	1	610-156/2J _____
VT750CDC Shadow	02-03	1	610-156/2611-146	1	610-156/2J _____
VT750CDD Shadow	02-03	1	610-156/2611-146	1	610-156/2J _____
VT750DC	01-09	1	610-156/2611-146	1	610-156/2J _____
Shadow Spirit 750					
VT750DCA	01-07	1	610-156/2611-146	1	610-156/2J _____
Shadow Spirit 750					
VT750DCB	01-07	1	610-156/2611-146	1	610-156/2J _____
Shadow Spirit 750					
PC800 Pacific Coast	89-90	2	610-156 611-146	2	_____
PC800 Pacific Coast	94-98	2	610-156 611-146	2	_____
VFR800 Interceptor	02-05	2	610-165/2610-165/2	2	610-165/2J 610-165/2J
VFR800 Interceptor	06-11	2	_____ 610-165/2	2	_____ 610-165/2J
VFR800A Interceptor	02-05	2	610-165/2610-165/2	2	610-165/2J 610-165/2J
VFR800A Interceptor	06-11	2	VD-172 610-165/2	2	_____
VFR800Fi Interceptor	98-01	2	610-165/2610-165/2	2	610-165/2J 610-165/2J
VT800C Shadow	1988	2	610-123 611-146	2	610-123J _____
CB900C Custom	1980	2	610-112 610-117	2	_____
CB900C Custom	1981	2	610-112/2610-117	2	_____
CB900C Custom	1982	2	610-123/2610-123	2	_____ 610-123J
CB900F Super Sport	81-82	2	610-123/2610-123	2	_____ 610-123J



## Honda Street

Model	Year	Kevlar		Sintered	
		Qt Front	Rear	Qt Front	Rear
CB900F Hornet	02-07	2	610-154 610-163	2	610-154J
CBR900RR	93-95	2	610-154 610-163	2	610-154J
CBR900RR	96-97	2	610-154/2610-163	2	
CBR900RR	98-99	2	610-166 610-163	2	
CBR929RE	2001	2	610-166/2610-163	2	
CBR929RR	00-01	2	610-166/2610-163	2	
CBR954RR	02-03	2	610-166/2610-163	2	
CB1000	94-95	2	610-154 610-163	2	610-154J
CB1000C Custom	1983	1	610-123/2610-123	1	610-123J
CBR1000F Hurricane	87-88	2	610-143 610-123/3	2	
CBR1000F Hurricane	90-91	2	610-156/2610-156/2	2	610-156/2J 610-156/2J
CBR1000F Hurricane	93-96	2	610-164 610-164	2	
CBR1000RR	04-05	2	610-163	2	
CBR1000RR	06-11	2	VD-170JL VD-174JL	2	
GL1000 Goldwing	75-77	2	610-112/2610-108	2	
GL1000 Goldwing	78-79	2	610-112 610-108	2	610-112J
GL1000L Goldwing LTD	1976	2	610-112/2610-108	2	
RVT1000R (RC51)	00-06	2	610-166/2610-163	2	
VF1000F Interceptor	1984	2	610-123 610-123/3	2	610-123J
VF1000R	85-86	2	610-123 610-140	2	610-123J
VTR1000F Super Hawk	98-05	2	610-154/2610-163	2	
CBX Super Sport	1979	2	610-112 610-112	2	610-112J 610-112J
CBX Super Sport	1980	2	610-112 610-112/2	2	610-112J
CBX Super Sport	81-82	2	610-123/2610-123	2	610-123J
CB1100F Super Sport	1983	2	610-123/2610-123	2	610-123J
CB1100 Hornet	1999	2	610-165 610-165	2	
CBR1100XX Blackbird	97-00	2	610-165/2610-165/2	2	610-165/2J 610-165/2J
CBR1100XX Blackbird	01-03	2	610-165/2610-165/2	2	610-165/2J
GL1100 Goldwing	80-81	2	610-112 610-112/2	2	610-112J
GL1100 Goldwing	82-83	2	610-123/2610-123	2	610-123J
GL1100A Aspencade	82-83	2	610-123/2610-123	2	610-123J
GL1100I Interstate	80-81	2	610-112 610-112/2	2	610-112J
GL1100I Interstate	82-83	2	610-123/2610-123	2	610-123J
ST1100	91-02	2	610-156 610-156/3	2	
ST1100A ABS	92-95	2	610-156 610-156/3	2	
ST1100A ABS	96-02	2	610-165/2610-165	2	610-165/2J
VF1100C V65 Magna	83-86	2	610-123 610-123/3	2	610-123J
VF1100S V65 Sabre	84-85	2	610-123 610-123/3	2	610-123J
VT1100C Shadow	85-86	1	610-123 611-146	1	610-123J
VT1100C Shadow	87-90	1	610-123/3611-146	1	610-123J
VT1100C Shadow	92-93	1	610-123/3611-146	1	610-123J
VT1100C Shadow	94-96	1	610-156/2611-146	1	610-156/2J
VT1100C Spirit	97-07	1	610-156/2611-146	1	610-156/2J
VT1100C2	95-01	1	610-156/2610-163	1	610-156/2J
Shadow A.C.E					
VT1100C2	00-07	1	610-156/2610-163	1	610-156/2J
Shadow Sabre					
VT1100C2-2	1997	1	610-156/2610-163	1	610-156/2J
Shadow 1100					
VT1100C3	98-02	1	610-156/2610-163	1	610-156/2J
Shadow Aero					
VT1100D2	1999	1	610-156/2610-163	1	610-156/2J
Shadow A.C.E.					
VT1100T	98-01	1	610-156/2610-163	1	610-156/2J
Shadow Tourer					
GL1200 Goldwing	1984	2	610-123/3610-123/3	2	
GL1200A Aspencade	84-87	2	610-123/3610-123/3	2	
GL1200I Interstate	84-87	2	610-123/3610-123/3	2	
GL1200L Goldwing LTD	1985	2	610-123/3610-123/3	2	
GL1200SEi Goldwing	1986	2	610-123/3610-123/3	2	
ST1300	02-07	2	610-165/2610-165	1	
ST1300A ABS	03-07	2	610-165/2610-165	1	
ST1300A ABS	08-11	2	VD-172JL 610-165	1	
VTX1300C	04-10	1	610-156/2610-163	1	610-156/2J
VTX1300R	05-09	1	610-156/2610-163	1	610-156/2J
VTX1300S	03-07	1	610-156/2610-163	1	610-156/2J
GL1500 Goldwing	88-90	2	610-143/2610-123/4	2	610-143/2J 610-123/4J
GL1500A Aspencade	91-00	2	610-143/2610-123/4	2	610-143/2J 610-123/4J
GL1500C Valkyrie	97-00	2	610-156 610-156/3	2	
GL1500C Valkyrie	2003	2	610-156 610-156/3	2	

## Honda Street

Model	Year	Kevlar		Sintered	
		Qt Front	Rear	Qt Front	Rear
GL1500CD Valkyrie	01-03	2	610-156 610-156/3	2	
GL1500CF	99-01	2	610-156 610-156/3	2	
Valkyrie Interstate					
GL1500CT	97-00	2	610-156 610-156/3	2	
Valkyrie Tourer					
GL1500I Interstate	91-96	2	610-143/2610-123/4	2	610-143/2J 610-123/4J
GL1500SE Goldwing	90-00	2	610-143/2610-123/4	2	610-143/2J 610-123/4J
GL1800 Goldwing	01-12	2	610-165/2	2	
GL1800A Goldwing	01-11	2	610-165/2610-165/2	2	
GL1800A Goldwing AB	01-11	2	610-165/2	2	
NRX1800DA/DB Rune	2004	2	610-165/2610-165/2	2	610-165/2J
NRX1800EA/EB Rune	2004	2	610-165/2610-165/2	2	610-165/2J
VTX1800C	02-04	2	610-165/2610-165	2	
VTX1800C1/C2/C3	03-08	2	610-165/2610-165	2	
VTX1800	05-11	2	610-165/2610-165	2	
VTX1800N	04-11	2	610-165/2610-165	2	
VTX1800R Retro	02-08	2	610-165/2610-165	2	610-165/2J
VTX1800R1/R2/R3	04-08	2	610-165/2610-165	2	
VTX1800S Retro	02-08	2	610-165/2610-165	2	
VTX1800S1/S2/S3	02-08	2	610-165/2610-165	2	
VTX1800T	07-11	2	610-165/2610-165	2	

## Honda ATV

ATC70	78-85	1	611-130	1	
TRX70 Fourtrax 70	86-87	1		1	
ATC90K1/K2/K3	70-75	1	611-135	1	611-135NS
ATC90	76-78	1	611-135	1	611-135NS
TRX90 Fourtrax 90	93-01	2	611-101 611-135	2	611-135NS
TRX90 Sportrax 90	02-06	2	611-101 611-135	2	611-135NS
TRX90EX	07-08	2	611-101 611-135	2	
TRX90X	09-12	2	611-101 611-135	2	
ATC110	79-85	1	611-135	1	611-135NS
ATC125M	84-87	1	611-101 611-135	1	611-135NS
TRX125 Fourtrax	85-88	2	611-101 611-135	2	611-135NS
ATC185	1980	1	611-101 611-135	1	611-135NS
ATC185S	81-83	1	611-101 611-135	1	611-135NS
ATC200	81-83	1	611-101 611-135	1	611-135NS
ATC200E Big Red	82-83	1	611-101 611-135	1	611-135NS
ATC200ES Big Red	1984	1	611-101 611-135	1	611-135NS
ATC200M	84-85	1	611-101 611-135	1	611-135NS
ATC200S	84-86	1	611-101 611-135	1	611-135NS
ATC200X	83-87	1	610-127 610-127/21	1	610-127J 610-127/2J
TRX200 Fourtrax 200	1984	2	611-147 611-135	2	611-135NS
TRX200 Fourtrax 200	90-91	2	611-152 611-135	2	611-135NS
TRX200D Type II	91-97	2	611-152 611-135	2	611-135NS
TRX200SX Fourtrax	86-88	2	611-152 611-135	2	611-135NS
ATC250ES Big Red	85-87	1	611-135 611-127	1	611-135NS
ATC250R	1981	1	610-120 611-135	1	611-135NS
ATC250R	82-84	1	610-127 610-127/21	1	610-127J 610-127/2J
ATC250R	85-86	1	610-134 610-134	1	610-134J 610-134J
ATC250SX	85-87	1	611-135 611-127	1	611-135NS
FL250 Odyssey	77-84	2	610-109 611-135	1	610-109NR 611-135NS
TRX250 Fourtrax	85-87	2	611-147 611-135	2	611-135NS
TRX250 Recon	97-01	2	611-152	2	
TRX250EX Sportrax	01-08	2	610-127	2	610-127J
TRX250R Fourtrax	86-89	2	610-139 610-134	2	610-139J 610-134J
TRX250TE	02-12	2	611-152	2	
Fourtrax Recon ES					
TRX250TE Recon	2006	2	611-152	2	
TRX250TM	02-12	2	611-152	2	
Fourtrax Recon					
TRX250TM Recon ES	02-12	2	611-152	2	
TRX250X Fourtrax	87-88	2	610-127 610-127/32	2	610-127J 610-127/3J
TRX250X Fourtrax	91-92	2	610-127 610-127/32	2	610-127J 610-127/3J
TRX300 Fourtrax	88-00	2	611-152 611-127	2	
TRX300EX Fourtrax	93-09	2	610-127 610-127	2	610-127J 610-127J
TRX300FW	1988	2	611-156 611-127	2	
Fourtrax 300 4x4					
TRX300FW	90-00	2	611-156 611-127	2	
Fourtrax 300 4x4					

# Brake Pads & Brake Shoes

## Honda ATV

Model	Year	Qt	Kevlar		Sintered	
			Front	Rear	Front	Rear
ATC350X	1985	1	610-134	610-127/21	610-134J	610-127/2J
ATC350X	1986	1	610-139	610-127/21	610-139J	610-127/2J
FL350R Odyssey	85-87	2	611-147	610-138	2	_____
TRX350 Fourtrax 4x4	86-87	2	611-153	611-146	2	_____
TRX350D Fourtrax Foreman 4x4	87-89	2	611-153	611-146	2	_____
TRX350FE	00-06	2	611-156	611-157	2	_____
Rancher 4x4 ES						
TRX350FM	00-06	2	611-156	611-157	2	_____
Rancher 4x4						
TRX350TE	00-06	2	611-156	611-157	2	_____
Rancher ES						
TRX350TM	00-06	2	611-156	611-157	2	_____
Fourtrax Rancher						
FL400R Pilot	89-90	2	611-147	610-138/22	_____	_____
TRX400EX	99-00	2	610-127	610-127	2	610-127J 610-127J
Fourtrax 400EX						
TRX400EX	01-08	2	610-127	610-127	2	610-127J 610-127J
Sportrax 400EX						
TRX400FA	04-07	2	611-156	611-157	2	_____
Fourtrax Rancher AT						
TRX400FGA	04-07	2	611-156	611-157	2	_____
Fourtrax Rancher AT						
TRX400FGA	2006	2	611-156	611-157	2	_____
Fourtrax Rancher AT GPS						
TRX400FM	2002	2	611-156	611-157	2	_____
Fourtrax Foreman						
TRX400FW	95-01	2	611-156	611-157	2	_____
Fourtrax Foreman						
TRX400FW	2003	2	611-156	611-157	2	_____
Fourtrax Foreman						
TRX400X	09-12	2	611-127	611-127	_____	611-127J 611-127J
TRX450ER	06-12	2	610-161	_____	2	_____
TRX450ES	98-03	2	611-156	611-157	2	_____
Fourtrax Foreman ES						
TRX450FE	02-04	2	611-156	611-157	2	_____
Fourtrax Foreman ES						
TRX450FM	02-04	2	611-156	611-157	2	_____
Fourtrax Foreman S						
TRX450R Sportrax	04-09	2	610-161	_____	2	_____
TRX450S	98-03	2	611-156	611-157	2	_____
Fourtrax Foreman						
TRX500FA	00-04	2	611-156	611-146	2	_____
Fourtrax Rubicon						
TRX500FA Rubicon	05-12	2	_____	611-146	2	_____
TRX500FE	05-11	2	_____	611-146	2	_____
Fourtrax Foreman 4x4 ES						
TRX500FGA	2004	2	611-156	611-146	2	_____
Foreman Rubicon						
TRX500FGA	2005	2	_____	611-146	2	_____
Foreman Rubicon						
TRX500FGA	06-08	2	_____	611-146	2	_____
Foreman Rubicon GPS						
TRX500FM	05-11	2	_____	611-146	2	_____
Fourtrax Foreman 4x4						
TRX500TM	05-06	2	_____	611-146	2	_____
Fourtrax Foreman						
TRX650FA Rincon	2003	2	611-156	_____	2	_____
TRX650FA	04-05	2	611-156	_____	2	_____
Fourtrax Rincon Gpscape						
TRX650FGA	04-05	2	611-156	_____	2	_____

## Honda Dual Sport & Offroad

CRF50F	04-12	1	611-134	611-134	1	_____
QA50K1/K2/K3	73-75	1	611-101	611-101	1	_____
XR50R	00-03	1	611-134	611-134	1	_____
ZB50	1988	1	611-101	611-101	1	_____
Z50AK0/AK1-AK6	68-75	1	611-101	611-101	1	_____
Z50A	76-78	1	611-101	611-101	1	_____

## Honda Dual Sport & Offroad

Model	Year	Qt	Kevlar		Sintered	
			Front	Rear	Front	Rear
Z50R	1979	1	611-101	611-101	1	_____
Z50R	80-89	1	611-134	611-134	1	_____
Z50R	91-99	1	611-134	611-134	1	_____
Z50RD Special	1986	1	611-134	611-134	1	_____
CR60R	83-84	1	611-150	611-150	1	611-150NS 611-150NS
CRF70F	04-12	1	611-150	611-150	1	611-150NS 611-150NS
CT70 Trail 70	76-79	1	611-101	611-101	1	_____
CT70 Trail 70	80-82	1	611-101	611-101	1	_____
CT70	91-94	1	611-101	611-101	1	_____
CT70HK0/HK1	70-73	1	611-101	611-101	1	_____
CT70K0 Trail 70	69-71	1	611-101	611-101	1	_____
CT70K1-K4 Trail 70	72-75	1	611-101	611-101	1	_____
SL70K0/K1	71-73	1	611-101	611-101	1	_____
XL70K0/K1_	74-75	1	611-126	611-126	1	611-126NS 611-126NS
XL70	1976	1	611-126	611-126	1	611-126NS 611-126NS
XR70R	97-03	1	611-150	611-150	1	611-150NS 611-150NS
XL75	77-79	1	611-126	611-126	1	611-126NS 611-126NS
XR75K0/K1/K2	73-75	1	611-101	611-101	1	_____
XR75	76-78	1	611-101	611-101	1	_____
CR80R	80-81	1	611-126	611-126	1	611-126NS 611-126NS
CR80R	1982	1	611-126	611-150	1	611-126NS 611-150NS
CR80R	83-85	1	611-150	611-150	1	611-150NS 611-150NS
CR80R	86-91	1	610-120	611-150	1	_____ 611-150NS
CR80R	92-00	1	610-120	610-144	1	_____
CR80R	01-02	1	610-127	610-144	1	610-127J _____
CR80RB Expert	96-00	1	610-120	610-144	1	_____
CR80RB Expert	01-02	1	610-127	610-144	1	610-127J _____
CRF80F	04-12	1	611-150	611-150	1	611-150NS 611-150NS
XL80S	80-85	1	611-126	611-126	1	611-126NS 611-126NS
XR80	79-84	1	611-126	611-126	1	611-126NS 611-126NS
XR80R	85-03	1	611-150	611-150	1	611-150NS 611-150NS
CR85R	03-07	1	610-127	610-144	1	610-127J _____
CR85RB Expert	03-07	1	610-127	610-144	1	610-127J _____
CT90K1-K4 Trail 90	69-73	1	611-101	611-101	1	_____
CT90K5/K6 Trail 90	74-75	1	611-101	611-126	1	_____ 611-126NS
CT90 Trail 90	76-79	1	611-101	611-126	1	_____ 611-126NS
EZ90 Cub	91-96	1	611-101	611-101	1	_____
SL90 Motosport 90	1969	1	611-101	611-101	1	_____
ST90K0/K1/K2	73-75	1	611-101	611-101	1	_____
CRF100F	04-12	1	611-150	611-150	1	611-150NS 611-150NS
SL100K0/K1/K2	70-73	1	611-101	611-126	1	_____ 611-126NS
XL100K0/K1	74-75	1	611-126	611-126	1	611-126NS 611-126NS
XL100	1976	1	611-126	611-126	1	611-126NS 611-126NS
XL100	77-78	1	611-101	611-126	1	_____ 611-126NS
XL100S	79-85	1	611-126	611-126	1	611-126NS 611-126NS
XR100	81-84	1	611-126	611-126	1	611-126NS 611-126NS
XR100R Pro-Link	85-03	1	611-150	611-150	1	611-150NS 611-150NS
CT110 Trail 110	80-86	1	611-101	611-126	1	_____ 611-126NS
CR125M Elsinore	76-78	1	611-126	611-126	1	611-126NS 611-126NS
CR125R	1982	1	_____	_____	1	_____
CR125R	1983	1	611-143	611-143	1	611-143NS 611-143NS
CR125R	84-85	1	610-134	611-143	1	610-134J 611-143NS
CR125R	1986	1	610-134	611-142	1	610-134J _____
CR125R	87-94	1	610-139	610-144	1	610-139J _____
CR125R	95-01	1	610-161	610-144	1	_____
CR125R	02-07	1	610-161	_____	1	_____
CT125 Trail 125	1977	1	611-126	611-126	1	611-126NS 611-126NS
MT125K0/K1 Elsinore	74-75	1	611-126	611-126	1	611-126NS 611-126NS
MT125 Elsinore	1976	1	611-126	611-126	1	611-126NS 611-126NS
SL125K0/K1/K2	71-73	1	611-101	611-126	1	_____ 611-126NS
NX125	88-90	1	611-142	611-126	1	_____ 611-126NS
TL125 Trials	73-75	1	611-126	611-126	1	611-126NS 611-126NS
TL125S Trials	1976	1	611-126	611-126	1	611-126NS 611-126NS
XL125K0/K1	74-75	1	611-126	611-126	1	611-126NS 611-126NS
XL125	1976	1	611-126	611-126	1	611-126NS 611-126NS
XL125	77-78	1	611-101	611-126	1	_____ 611-126NS
XL125S	79-82	1	611-126	611-126	1	611-126NS 611-126NS
XL125S	1984	1	611-126	611-126	1	611-126NS 611-126NS
XL125S	1985	1	_____	611-126	1	_____ 611-126NS
CRF150F	03-05	1	610-161	_____	_____	_____



## Honda Dual Sport & Offroad

Model	Year	QtKevlar		Kevlar		QtSintered		Sintered	
		Front	Rear	Front	Rear	Front	Rear	Front	Rear
MR175	75-77	1	611-126	611-126	1	611-126NS	611-126NS		
SL175K0/K1	70-72	1	611-139	611-139	1				
XL175K0/K1/K2	73-75	1	611-125	611-130	1				
XL175	76-78	1	611-125	611-130	1				
XL185	79-83	1	611-126	611-126	1	611-126NS	611-126NS		
XR185	1979	1	611-126	611-126	1	611-126NS	611-126NS		
TLR200 Reflex	86-87	1	611-126	611-126	1	611-126NS	611-126NS		
TR200 Fatcat	86-87	1	611-126	611-126	1	611-126NS	611-126NS		
XL200R Dual Sport	83-84	1	611-126	611-126	1	611-126NS	611-126NS		
XR200	80-84	1	611-126	611-126	1	611-126NS	611-126NS		
XR200R Pro-Link	81-83	1	611-126	611-126	1	611-126NS	611-126NS		
XR200R	84-02	1	611-126	611-126	1	611-126NS	611-126NS		
CRF230F	03-09	1	610-161		1				
CR250R	84-85	1	610-134	611-143	1	610-134J	611-143NS		
CR250R	1986	1	610-134	611-142	1	610-134J	611-142NS		
CR250R	87-94	1	610-139	610-144	1	610-139J	610-144J		
CR250R	95-01	1	610-161	610-144	1		610-144J		
CR250R	02-07	1	610-161		1				
CRF250R	04-12	1	610-161		1				
CRF250X	04-12	1	610-161		1				
NX250	88-89	1	610-139	611-140	1	610-139J	611-140NS		
NX250	1990	1	610-161	611-140	1		611-140NS		
XL250K0	72-73	1	611-124	611-125	1				
XL250K1/K2	74-75	1	611-124	611-125	1				
XL250	1976	1	611-124	611-125	1				
XR250	79-80	1	611-125	611-140	1		611-140NS		
XR250L Dual Sport	91-96	1	610-161	610-144	1		610-144J		
XR250R	81-82	1	611-149	611-140	1	611-149NS	611-140NS		
XR250R	84-87	1	610-134	611-126	1	610-134J	611-126NS		
XR250R	88-91	1	610-139	611-126	1	610-139J	611-126NS		
XR250R	92-95	1	610-139	610-144	1	610-139J			
XR250R	96-04	1	610-161	610-144	1				
SL350K0	1970	1	611-119	611-127	1				
SL350K1/K2	71-72	1		611-139	1				
XL350K0/K1	74-75	1	611-124	611-125	1				
XL350	76-78	1	611-124	611-125	1				
XL350R	84-85	1	610-134	611-140	1		611-140NS		
XR350R	1983	1	611-143	611-126	1	611-143NS	611-126NS		
XR350R	84-85	1	610-134	611-126	1		611-126NS		
XR400R	96-04	1	610-161	610-144	1				
CR450R	1981	1	611-149	611-159	1	611-149NS			
CRF450R	02-12	1	610-161		1	610-161JL			
CRF450X	05-12	1	610-161		1				
CR480R	1982	1	611-149	611-159	1	611-149NS			
CR480R	1983	1	611-144	611-142	1				
CR500R	84-85	1	610-134	611-143	1		611-143NS		
CR500R	1986	1	610-134	611-142	1				
CR500R	87-94	1	610-139	610-144	1				
CR500R	95-01	1	610-161	610-144	1				
XL500R	1982	1	611-148	611-136	1				
XL500R	83-84	1	610-134	611-136	1	610-134J			
XL500S	79-80	1	611-125	611-136	1				
XL500S	1981	1	611-138	611-139	1				
XR500	79-80	1	611-137	611-136	1				
XR500R	81-82	1	611-149	611-136	1	611-149NS			
XR500R	83-84	1	610-134	611-126	1	610-134J	611-126NS		
XL600R	83-87	1	610-134	611-136	1	610-134J			
XL600V Transalp	89-90	1	610-123	611-136	1	610-123J			
XR600R	85-87	1	610-134	611-126	1	610-134J	611-126NS		
XR600R	88-90	1	610-139	611-126	1	610-139J	611-126NS		
XR600R	91-92	1	610-139	610-144/21	1	610-139J			
XR600R	1993	1	610-161	610-144	1				
XR600R	94-00	1	610-139	610-144	1				
NX650	88-89	1	610-143/2611-136	1	610-143/2J				
XR650L Dual Sport	93-12	1	610-161	610-144	1				
XR650R	00-07	1	610-161	610-144	1				

## Kawasaki Street

Model	Year	QtKevlar		Kevlar		QtSintered		Sintered	
		Front	Rear	Front	Rear	Front	Rear	Front	Rear
AR50A1	1982	1	610-342	611-312	1				
AR80A1	1982	1	610-342	611-312	1				
G3SS/A/B/C/D/E-90	69-75	1	611-312	611-312	1				
G3TR-90 Bushmaster	69-70	1	611-312	611-312	1				
MC1/MC1A/MC1B-90	73-75	1	611-312	611-312	1				
G3TRA-100	1971	1	611-312	611-312	1				
G4TR/A-100 Trail Boss	70-71	1	611-312	611-312	1				
G4TRB/C/D/E-100	72-75	1	611-312	611-312	1				
G5/G5A/G5B/G5C-100	72-75	1	611-312	611-312	1				
KD100M1-M4	76-79	1	611-312	611-312	1				
KE100A5-A10	76-81	1	611-312	611-312	1				
KE100B1-B20	82-80	1	611-312	611-312	1				
KH100B7/B8	76-77	1	611-312	611-312	1				
KM100A1-A7	76-81	1	611-312	611-312	1				
KV100A7	1976	1	611-312	611-312	1				
C2SS-120 Roadrunner	67-69	1	611-312	611-312	1				
C2TR-120 Roadrunner	67-69	1	611-312	611-312	1				
BN125A1/A9F	98-09	1		611-409	1				
F6/A/B-125 Enduro	71-73	1	611-302	611-302	1				
KE125A3-A10	76-83	1	611-408	611-409	1				
KS125/A	74-75	1	611-408	611-409	1				
F3-175	68-70	1		611-309	1				
F7/A/B-175 Enduro	71-73	1	611-302	611-302	1				
F7C/D-175 Enduro	74-75	1	611-409	611-409	1				
KE175B1/B2/B3	76-78	1	611-408	611-411	1		611-411NS		
KE175D2-D5	80-83	1	611-408	611-416	1				
KZ200A1/A2	78-79	1	610-309	611-409	1				
EL250B2/B3 Eliminator	88-89	1	610-426	611-413	1	610-426J			
EL250E1 Eliminator	1991	1	610-426	611-413	1	610-426J			
EX250E Ninja 250R	86-87	1	610-426	610-426	1	610-426J	610-426J		
EX250F Ninja 250R	88-90	1	610-427	610-430	1	610-427J	610-430J		
EX250F5-F19 Ninja 250R	92-05	1	610-427	610-430	1	610-427J	610-430J		
EX250D6F-D7FNinja 250R	06-07	1	610-427	610-430	1	610-427J	610-430J		
EX250J8F-JCF Ninja 250R	08-12	1	VD-250JLVD-250JL1	SD-250	SD-250				
F8-250 Enduro	71-72	1	611-309	611-309	1				
F11/A/B-250	73-75	1	611-309	611-309	1				
KE250B1/B2/B3	77-79	1	611-411	611-309	1				
KH250A5	1976	1		611-404	1				
KL250A1/A1A/A2	78-79	1	611-411	611-309	1				
KL250A3/A4/A5	80-82	1	611-408	611-416	1				
KL250C1/C2	83-84	1	611-408	611-416	1				
KL250D2-D22 KLR	85-05	1	610-425	611-416	1	610-425J			
KL250G4/G5/G6/G7	00-03	1		610-425	1				
Super Sherpa									
KZ250D1 LTD	1980	1	611-309	611-409	1				
KZ250D2 CSR	1981	1	611-309	611-409	1				
KZ250L1 CSR	1982	1	611-309	611-409	1				
KZ250W1 LTD	1983	1	611-309	611-409	1				
S1A/S1B/S1C-250	73-75	1		611-404	1				
EX305B1 GPz	1983	1	610-426	611-413	1	610-426J			
KZ305A1/A2 CSR	81-82	1	610-420/2	611-413	1	610-420/2J			
KZ305B1 LTD	1982	1	610-420/2	611-413	1	610-420/2J			
KZ305B2/B3 LTD	87-88	1	610-420/2	611-413	1	610-420/2J			
S2/S2A-350	72-73	1		611-404	1				
KH400A3/A4/A5	76-78	1	610-414	611-404	1				
KLX400A1 Dual Sport	2003	1	610-161	610-144	1				
KZ400A1/A2 Deluxe	77-78	1		611-404	1				
KZ400B1/B2	78-79	1	611-413	611-413	1				
KZ400C1	1978	1		611-413	1				
KZ400/D/D3/D4	74-77	1		611-404	1				
KZ400H1 LTD	1979	1	610-414	611-413	1				
KZ400S/S2/S3I	75-77	1		611-404	1				
S3/S3A-400	74-75	1		611-404	1				
KZ440A1/A2/A3 LTD	80-82	1	610-414	611-413	1				
KZ440A4 LTD	1983	1	610-420/2	611-413	1	610-420/2J			
KZ440B1/B2	80-81	1		611-413	1				
KZ440D1-D4 LTD	80-82	1	610-414	611-413	1				
KZ440D5 LTD	1983	1	610-420/2	611-413	1	610-420/2J			
KZ440G1	1983	1	610-420/2	611-413	1	610-420/2J			
EN450A1-A6 454 LTD	85-90	1	610-426	611-412	1	610-426J			



# Brake Pads & Brake Shoes

## Kawasaki Street

Model	Year	Qt	Kevlar Front	Kevlar Rear	Qt	Sintered Front	Sintered Rear
EN500A1-A7 Vulcan	90-96	1	610-426	611-412	1	610-426J	—
EN500C1-C10 Vulcan	96-05	1	610-426	611-412	1	610-426J	—
EN500C6F/C7F	06-09	1	610-426	611-412	1	610-426J	—
EX500A1-A7	87-93	1	610-427	611-412	1	610-427J	—
EX500D1-D3 Ninja 500	94-96	1	610-427	610-425	1	610-427J	610-425J
EX500D4-D12 500R	97-05	1	610-427	610-425	1	610-427J	610-425J
EX500D6F/D7F	06-09	1	610-427	610-425	1	610-427J	610-425J
H1D/E/F-500	73-75	1	610-414	—	1	—	—
H1 500	69-71	1	611-420	611-420	1	—	—
KH500A8	1976	1	610-414	—	1	—	—
KZ550A1	1980	1	610-414	611-412	1	—	—
KZ550A2/A3/A4	81-83	1	610-420/2	611-412	1	610-420/2J	—
KZ550C1-C4 LTD	80-83	1	610-420/2	611-412	1	610-420/2J	—
KZ550D1 GPz	1981	2	610-420	610-420/2	2	610-420J	610-420/2J
KZ550F1 Spectre	1983	1	610-420/2	611-412	1	610-420/2J	—
KZ550F2 LTD	1984	1	610-420/2	611-412	1	610-420/2J	—
KZ550H1/H2 GPz	82-83	2	610-420	610-420/2	2	610-420J	610-420/2J
KZ550M1 LTD	1983	1	610-420/2	611-412	1	610-420/2J	—
ZR550B1/B2/B3 Zephyr	90-92	2	610-427	610-430	2	610-427J	610-430J
ZR550B4 Zephyr	1993	2	610-427	610-434	2	—	—
ZX550A1/A2/A3 GPz	84-86	2	610-426	610-426	2	610-426J	610-426J
KL600A1 KLR600	1984	1	610-425	611-409	1	610-425J	—
KL600/B1/B2 KLR600	85-86	1	610-425	611-409	1	610-425J	—
ZL600A1/A2 Eliminator	86-87	1	610-426	611-412	1	610-426J	—
ZL600B1/B2 Eliminator	96-97	1	610-427/2	611-412	1	—	—
ZX600A1/A2/A3 Ninja	85-87	2	610-426	610-426	2	610-426J	610-426J
ZX600B1 Ninja 600RX	1987	2	610-426	610-426	2	610-426J	610-426J
ZX600C1-C10 Ninja	88-97	2	610-427	610-427	2	610-427J	610-427J
ZX600D1-D4 Ninja ZX690	93	2	610-344/2	610-427	2	—	610-427J
ZX600E1-E10 ZX-6	93-02	2	610-344	610-434	2	610-344J	—
ZX600E11 ZZR600	2003	2	610-344	610-434	2	610-344J	—
ZX600E12 ZZR600	2004	2	610-434	610-434	2	—	—
ZX600F1/F2/F3 ZX-6R	95-97	2	610-344	610-434	2	610-344J	—
ZX600G1/G2 Ninja ZX-6R	98-99	2	610-349	610-434	2	610-349J	—
ZX600J1/J2/J3 Ninja ZX-6R	00-02	2	610-349	610-434	2	610-349J	—
ZX600J4/J6F/J7F	05-07	2	610-349	610-434	2	610-349J	—
ZZR600	—	—	—	—	—	—	—
ZX600K1 ZX-6RR	2003	2	—	610-434	2	—	—
ZX600M1 ZX-6RR	2004	2	—	610-434	2	—	—
ZX600N1/N6F ZX-6RR	05-06	2	—	610-434	2	—	—
ZX600	07-12	2	VD-444JL	VD-434VL	2	—	—
ZX636B1/B2 ZX-6R	03-04	2	—	610-434	2	—	—
ZX636C1/C6F	05-06	2	—	610-434	2	—	—
Ninja ZX-6R	—	—	—	—	—	—	—
EJ650A2/A3 W650	00-01	1	—	611-413	1	—	—
EX650 Ninja 650R	06-09	1	610-352-L	610-434	1	—	—
KL650A1-A19 KLR	87-05	1	610-428	610-425	1	610-428J	610-425J
KL650A6F/A7F KLR	06-07	1	610-428	610-425	1	610-428J	610-425J
KL650 KLR	08-12	1	VD-340JL	VD-250JL	1	—	—
KL650B2/B3 Tengai	90-91	1	610-427	610-425	1	610-427J	610-425J
KLX650C1-C4 Dual	93-96	1	610-161	610-432	1	—	—
KZ650B1/B2/B2A/B3	77-79	1	610-414	611-412	1	—	—
KZ650C1-C3 Custom	77-79	2	610-414	610-412	2	—	—
KZ650D1/D1A/D2 SR	78-79	2	610-414	610-306	2	—	610-306J
KZ650E1 LTD	1980	1	610-414	611-412	1	—	—
KZ650F1	1980	1	610-414	611-412	1	—	—
KZ650H1/H2/H3 CSR	81-83	1	610-420/2	611-412	1	—	—
KZ700A1	1984	2	610-420	610-420/2	2	610-420J	610-420/2J
VN700A1 Vulcan	1985	2	610-426	611-412	2	610-426J	—
ZN700A1/A2 LTD	84-85	2	610-426	610-426	2	610-426J	610-426J
H2/A/B/C-750	72-75	1	610-301	611-405	1	—	—
KZ750B1/B2/B3/B4	76-79	1	610-414	610-412	1	—	—
KZ750E1/E2/E3	80-82	2	610-420	610-420/2	2	610-420J	610-420/2J
KZ750F1 LTD	1983	2	610-420	610-420/2	2	610-420J	610-420/2J
KZ750G1 LTD (2 cyl.)	1980	1	610-414	611-412	1	—	—
KZ750H1-H4 LTD	80-83	2	610-420	610-420/2	2	610-420J	610-420/2J
KZ750K1/K2 LTD	83-84	—	—	611-412	1	—	—

## Kawasaki Street

Model	Year	Qt	Kevlar Front	Kevlar Rear	Qt	Sintered Front	Sintered Rear
KZ750L3	1983	2	610-420	610-420/2	2	610-420J	610-420/2J
KZ750M1 CSR (2 cyl.)	1982	1	610-420/2	611-412	1	610-420/2J	—
KZ750N1/N2 Spectre	82-83	2	610-420	610-420/2	2	610-420J	610-420/2J
KZ750R1 GPz	1982	2	610-420	610-420/2	2	610-420J	610-420/2J
VN750A2-A21 Vulcan	86-05	2	610-426	611-412	2	610-426J	—
VN750A6F Vulcan	2006	2	610-426	611-412	2	610-426J	—
ZR750C1-C3 Zephyr	91-93	2	610-427	610-427	2	610-427J	610-427J
ZR750F2 ZR-7	2000	1	610-352-L	—	1	—	—
ZR750H1-H3 ZR-7S	04-06	1	610-352-L	—	1	—	—
ZX750A1-A3 GPz	83-85	2	610-426	610-426	2	610-426J	610-426J
ZX750E1/E2 GPz	84-85	2	610-426	610-426	2	610-426J	610-426J
ZX750F1-F4 Ninja R	87-90	2	610-427	610-427	2	610-427J	610-427J
ZX750H Ninja ZX-7	89-90	2	610-344/3	610-327/2	2	610-344/3J	610-327/2J
ZX750J Ninja ZX-7	91-92	2	610-344/3	610-327/2	2	610-344/3J	610-327/2J
ZX750K Ninja ZX-7R	91-92	2	610-344/3	610-327/2	2	610-344/3J	610-327/2J
ZX750LNinja ZX-7	93-95	2	610-344	610-327/2	2	610-344J	610-327/2J
ZX750M Ninja ZX7-R	93-94	2	610-344	610-327/2	2	610-344J	610-327/2J
ZX750N ZX7-RR	96-97	2	610-437	—	2	—	—
ZX750P1-P8 ZX7-R	96-03	2	610-349	610-327/2	2	610-349J	610-327/2J
VN800A1-A11 Vulcan	95-05	1	610-426	611-412	1	610-426J	—
VN800B1-B10 Classic	96-05	1	610-352	611-412	1	—	—
VN800C Vulcan Drifter	99-00	1	610-352	—	1	—	—
VN800E Vulcan Drifter	01-06	1	610-352	—	1	—	—
Z1/A/B-900	73-75	1	610-301	611-405	1	—	—
KZ900A4/A5	76-77	1	610-414	611-405	1	—	—
KZ900B1 LTD	1976	2	610-414	610-412	2	—	—
ZL900A1/A2 Eliminator	86-87	2	610-426	610-426	2	610-426J	610-426J
ZX900A1-A3 Ninja	84-86	2	610-426	610-426	2	610-426J	610-426J
ZX900B Ninja ZX-9R	94-96	2	610-344	610-434	2	610-344J	—
ZX900B4 Ninja ZX-9R	1997	2	610-349	610-434	2	610-349J	—
ZX900C Ninja ZX-9R	98-99	2	610-349	610-434	2	610-349J	—
ZX900E Ninja ZX-9R	00-01	2	610-349	610-434	2	610-349J	—
ZX900F Ninja ZX-9R	02-03	2	610-443	610-434	2	—	—
KZ1000A1/A2/A2A	77-78	1	610-414	610-412	1	—	—
KZ1000A3/A3A/A4 MKII	79-80	2	610-414	610-306/2	2	—	—
KZ1000B1/B2 LTD	77-78	2	610-414	610-412	2	—	—
KZ1000B3/B4 LTD	79-80	2	610-414	610-306/2	2	—	—
KZ1000C1/C1A	1978	2	610-414	610-306	2	—	610-306J
KZ1000C2-4 Police	79-81	2	610-414	610-306/2	2	—	—
KZ1000D1 Z1R	1978	2	610-414	610-306/2	2	—	—
KZ1000D3 Z1R	1980	2	610-414	610-306/2	2	—	—
KZ1000E Shaft ST	79-80	2	610-414	610-306/2	2	—	—
KZ1000G1 LTD Classic	1980	2	610-414	610-306/2	2	—	—
KZ1000J1/J2/J3	81-83	2	610-420	610-420/2	2	610-420J	610-420/2J
KZ1000K1/K2 LTD	81-82	2	610-420	610-420/2	2	610-420J	610-420/2J
KZ1000M1/M2 CSR	81-82	2	610-420	610-420/2	2	610-420J	610-420/2J
KZ1000P1-P20 Police	82-01	2	610-420	610-420/2	2	610-420J	610-420/2J
KZ1000P21/P22 Police	02-03	1	610-352-L	—	1	—	610-435/2J
KZ1000P24 Police	2005	1	610-352-L	—	1	—	610-435/2J
KZ1000R1/R2 Replica	82-83	2	610-420	610-420/2	2	610-420J	610-420/2J
ZG1000A1-A8 Concours	86-93	2	610-426	610-426	2	610-426J	610-426J
ZG1000A9-A20	94-05	2	610-427	610-426	2	610-427J	610-426J
ZG1000A6F Concours	2006	2	610-427	610-426	2	610-427J	610-426J
ZL1000A1 Eliminator	1987	2	610-426	610-426	2	610-426J	610-426J
ZR1000A ZX1000	03-06	2	610-443	610-434	2	—	—
ZX1000A1/A2 Ninja	86-87	2	610-426	610-426	2	610-426J	610-426J
ZX1000B Ninja ZX-10	88-90	2	610-427	610-427	2	610-427J	610-427J
ZX1000C1/C2 ZX-10R	04-05	2	—	610-434	2	—	—
ZX1000D6F ZX-10R	06-07	2	—	610-434	—	—	—
ZX1000 JBF-JCF	11-12	2	VD-355JL	VD-174JL	—	—	—
KZ1100A1/A2/A3 Shaft	81-83	2	610-420	610-420/2	2	610-420J	610-420/2J
KZ1100B1/B2 GPz	81-82	2	610-420	610-420/2	2	610-420J	610-420/2J
KZ1100D1/D2 Spectre	82-83	2	610-420	610-420/2	2	610-420J	610-420/2J
KZ1100L1 LTD	1983	2	610-420	610-420/2	2	610-420J	610-420/2J
ZN1100B1/B2 LTD	84-85	2	610-426	610-426	2	610-426J	610-426J
ZR1100A1/A2/A3/A4	92-95	2	610-344	610-427	2	610-344J	610-427J



## Kawasaki Street

Model	Year	Qt	Kevlar		Sintered	
			Front	Rear	Front	Rear
ZR1100C3/C4	99-00	2	610-349	610-327/22	610-349J	610-327/2J
ZRX1100						
ZX1100A1/A2 GPz	83-84	2	610-426	610-426	610-426J	610-426J
ZX1100C1 Ninja ZX-11	1990	2	610-344/3	610-427	610-344/3	610-427J
ZX1100C2-C4 ZX-11	91-93	2	610-344	610-427	610-344J	610-427J
ZX1100D1-D9 ZX-11	93-01	2	610-344	610-327/22	610-344J	610-327/2J
ZX1100E1/E2/E3 GPz	95-97	1	610-352-L	610-434	1	1
		1	—R	—	1	—
ZX1100F1 GPz ABS	1996	1	610-352-L	610-434	1	1
		1	—R	—	1	—
ZG1200A1 Voyager XII	1986	2	610-426	610-426	610-426J	610-426J
ZG1200B Voyager XII	87-03	2	610-426	610-426	610-426J	610-426J
ZR1200A ZRX1200	01-05	2	610-349	610-327/22	610-349J	610-327/2J
ZX1200A ZX-12R	00-01	2	610-349	610-327/22	610-349J	610-327/2J
ZX1200B ZX-12R	02-03	2	610-349	610-327/22	610-349J	610-327/2J
ZX1200B ZX-12R	04-05	2	—	610-327/22	—	610-327/2J
ZX1200C ZZR1200	02-05	2	610-344	610-327/22	610-344J	610-327/2J
KZ1300A1/A2/A3/A4	79-82	2	610-423	610-306/22	—	—
KZ1300B2 Tourer	1980	2	610-426	610-306/22	610-426J	—
ZN1300A1-A6 Voyager	83-88	2	610-426	610-426	610-426J	610-426J
ZX1400A6F-A7F ZX-1406-07	2	—	—	—	2	—
ZX1400 C8F-CAF	08-10	2	—	—	2	—
VN1500A Vulcan 88	87-95	1	610-426	610-426	610-426J	610-426J
VN1500A Vulcan 1500	96-99	1	610-426	610-426	610-426J	610-426J
VN1500B Vulcan 88 SE	97-90	1	610-426	610-426	610-426J	610-426J
VN1500C Vulcan 1500L	96-97	1	610-426	610-426	610-426J	610-426J
VN1500D Classic	96-97	1	610-352	610-426	1	610-426J
VN1500E Classic	98-00	1	610-352	610-426	1	610-426J
VN1500E Classic	01-04	1	610-352	—	1	—
VN1500G Nomad	99-00	1	610-352-L	610-426	1	610-426J
		1	—R	—	1	—
VN1500G Nomad	2001	1	610-352-L	—	1	610-435/2J
		1	—R	—	1	—
VN1500J Drifter	99-00	1	610-352	—	1	—
VN1500L Nomad F.I.	2000	1	610-352-L	—	1	—
		1	—R	—	1	—
VN1500L Nomad F.I.	01-04	1	610-352-L	—	1	610-435/2J
		1	—	—	1	—
VN1500N Classic F.I.	2000	1	610-352	—	1	—
VN1500N Classic F..I	01-04	1	610-352	—	1	610-435/2J
VN1500N Classic	04-08	1	610-352	—	1	610-435/2J
VN1500P Mean Streak	02-03	2	610-349	—	2	610-349J
VN1500R Drifter	01-05	1	610-352	—	1	—
VN1500T6F Classic	2006	1	610-352	—	1	—
VN1600A Classic	03-08	1	610-352-L	—	1	—
		1	—R	—	1	—
VN1600B Mean Streak	2004	2	610-349	—	2	610-349J
VN1600B Mean Streak	05-08	2	—	—	2	610-435/2J
VN1600D Nomad	05-08	1	610-352-L	—	1	—
		1	—R	—	1	—
VN1600E6F Classic	2006	1	610-352-L	—	1	—
		1	—R	—	1	—
VN1600F Mean Streak	2006	2	—	—	2	610-435/2J
VN2000A Vulcan 2000	04-07	2	610-344	—	2	610-344J
VN2000D1/D6F Limited	05-10	2	610-344	—	2	610-344J

## Kawasaki ATV

KSF50A1-A6F KFX50	03-06	2	611-323	611-310	2	—	—
KSF80A1-A6F KFX80	03-06	2	611-323	611-314	2	—	—
KLF110A1/A2 Mojave	87-88	2	611-312	611-409	2	—	—
KLF110B1/B2 Mojave	87-88	2	611-312	611-409	2	—	—
KLT110A1/A2/A3	84-86	1	611-312	611-409	1	—	—
KLT160A1	1985	1	611-312	611-409	1	—	—
KLF185A1 Bayou	1985	1	—	611-413	1	—	—
KLF185A2-A4 Bayou	86-88	2	611-411	611-413	2	611-411NS	—
KLT185A1/A2	86-87	1	611-312	611-409	1	—	—
KLT200A1-A4	81-83	1	611-312	611-411	1	—	611-411NS
KLT200B1	1983	1	611-312	611-411	1	—	611-411NS
KLT200C1/C2	83-84	1	611-312	611-411	1	—	611-411NS

## Kawasaki ATV

Model	Year	Qt	Kevlar		Sintered		
			Front	Rear	Front	Rear	
KLF220A1-A15 Bayou	88-02	2	611-411	611-413	2	611-411NS	—
KLF250A1-A6F Bayou	03-06	2	611-411	611-413	2	611-411NS	—
KLT250A1/A2	82-83	1	611-312	611-411	1	—	611-411NS
KLT250C Prairie	83-85	1	611-312	611-411	1	—	611-411NS
KLT250P1 Police	1984	1	611-312	611-411	1	—	611-411NS
KSF250A1-A18 Mojave	87-03	2	610-425	610-127/22	2	610-425J	610-127/2J
KXF250A1/A2 Tecate	487-88	2	610-425	610-127/22	2	610-425J	610-127/2J
KXT250A1 Tecate 3	1984	1	611-411	610-342	1	611-411NS	—
KXT250A2 Tecate 3	1985	1	610-425	610-425	1	610-425J	610-425J
KXT250B1 Tecate 3	1986	1	610-425	610-425	1	610-425J	610-425J
KXT250B2 Tecate 3	1987	1	610-425	610-127/22	1	610-425J	610-127/2J
KEF300A Lakota 300	95-00	2	610-425	610-127/22	2	610-425J	610-127/2J
KEF300B Lakota Sport	01-03	2	610-425	610-127/22	2	610-425J	610-127/2J
KLF300A1/A2 Bayou	86-87	2	611-418	611-413	2	—	—
KLF300B1-B17 Bayou	88-04	2	610-425	611-413	2	610-425J	—
KLF300C Bayou 4x4	89-04	1	610-250-L	611-419	1	—	—
		1	610-340-R	—	1	—	—
KVF300A Prairie 4x4	99-02	2	610-120	611-419	2	—	—
KVF300B Prairie 300	99-02	2	610-120	611-419	2	—	—
KVF360A Prairie 4x4	03-12	2	610-120	—	2	—	—
KVF360B Prairie 300	03-12	2	610-120	—	2	—	—
KVF360C Prairie 360	2003	2	610-120	—	2	—	—
4x4 Advantage Classic							
KVF360C Prairie 360	04-10	2	610-120	—	2	—	—
4x4 Hardwoods Green							
KLF400B Bayou 4x4	93-99	1	610-250-L	611-419	1	—	—
		1	610-340-R	—	1	—	—
KSF400A KFX400	03-06	2	610-127/2	610-340	2	610-127/2J	—
KVF400APrairie 4x4	97-98	2	610-120	611-419	2	—	—
KVF400B1 Prairie 400	1998	2	610-120	611-419	2	—	—
KVF400C Prairie 4x4	99-02	2	610-120	611-419	2	—	—
KVF400D Prairie 400	99-02	2	610-120	611-419	2	—	—
KVF650A/B Prairie 650	02-03	1	—	—	1	—	—
		1	—	—	1	—	—
KVF650D1/D6F/D7F	05-12	1	—	—	1	—	—
Brute Force 650 4x4		1	—	—	1	—	—
KVF650E1/E6F/E7F	05-09	1	—	—	1	—	—
Brute Force 650 4x4		1	—	—	1	—	—
Hardwoods Green HD							
KVF650F6F/H7F	06-12	1	610-250-L	—	1	—	—
Brute Force 650 4x4i		1	610-340-R	—	1	—	—
KVF650G6F/G7F	06-09	1	610-250-L	—	1	—	—
Brute Force 650 4x4i Realtree		1	610-340-R	—	1	—	—
Hardwoods Green HD							
KSV700A1/A2/A6F/A7F	04-09	1	—	—	1	—	—
KFX700 V-Force		1	—	—	1	—	—
KSV700B1/B2/B6F/B7F	04-09	1	—	—	1	—	—
KFX700 V-Force		1	—	—	1	—	—
KSV700C6F	2006	1	—	—	1	—	—
KFX700 V-Force		1	—	—	1	—	—
KVF700A1/A2/A6F	04-06	1	—	—	1	—	—
KVF700B1/B2	04-05	1	—	—	1	—	—
Prairie 700 4x4		1	—	—	1	—	—
KVF700D1/D6F	05-06	1	—	—	1	—	—
Prairie Special Edition		1	—	—	1	—	—
KVF750A1/A6F	05-12	1	610-250-L	—	1	—	—
Brute Force 750 4x4i		1	610-340-R	—	1	—	—
KVF750B6F/C6F	06-12	1	610-250-L	—	1	—	—
Brute Force 750 4x4i		1	610-340-R	—	1	—	—

# Brake Pads & Brake Shoes

## Kawasaki Dual Sport & Offroad

Model	Year	Qt	Kevlar Front	Kevlar Rear	Qt	Sintered Front	Sintered Rear
KX60A1/A2	83-84	1	611-417	611-417	1	—	—
KX60B1-B19	85-03	1	611-417	611-417	1	—	—
KX65A1/-ACF	00-12	1	—	610-120	1	—	—
KD80A1/A2	75-76	1	611-312	611-312	1	—	—
KD80M1-M8	80-87	1	611-312	611-312	1	—	—
KD80N1/N2/N3	88-90	1	610-342	611-312	1	—	—
KDX80A1/A2	80-81	1	611-414	611-414	1	—	—
KDX80B1/B2	82-83	1	611-414	611-414	1	—	—
KDX80C1/C2/C3/C4/C5	84-88	1	611-415	611-415	1	—	—
KX80A1/A2	79-80	1	611-414	611-414	1	—	—
KX80C1/C2	81-82	1	611-414	611-414	1	—	—
KX80E1	1983	1	611-415	611-417	1	—	—
KX80E2/E3	84-85	1	610-342	611-417	1	—	—
KX80G1/G2	86-87	1	610-342	611-417	1	—	—
KX80J2	1987	1	610-342	611-417	1	—	—
KX80L1/L2/L3	88-90	1	610-342	610-127	1	—	610-127J
KX80N1/N2/N3	88-90	1	610-342	610-127	1	—	610-127J
KX80R1-R6	91-96	1	610-342	610-127	1	—	610-127J
KX80R7	1997	1	610-438	610-127	1	—	610-127J
KX80T1/T2/T3/T4	91-94	1	610-342	610-127	1	—	610-127J
KX80W1/W2/W3	98-00	1	610-438	610-127	1	—	610-127J
KX85A1-ACF	01-12	1	610-438	610-127	1	—	610-127J
MC1/MC1A/MC1B-90	73-75	1	611-312	611-312	1	—	—
G3TR-90 Bushmaster	69-70	1	611-312	611-312	1	—	—
MC1/MC1A/MC1B-90	73-75	1	611-312	611-312	1	—	—
G3TRA-100 Bushmaster	1971	1	611-312	611-312	1	—	—
G4TR/A-100 Trail Boss	70-71	1	611-312	611-312	1	—	—
G4TRB/C/D/E-100	72-75	1	611-312	611-312	1	—	—
G5/G5A/G5B/G5C-100	72-75	1	611-312	611-312	1	—	—
KD100M1-M4	76-79	1	611-312	611-312	1	—	—
KE100A5-A10	76-81	1	611-312	611-312	1	—	—
KE100B1-B20	82-80	1	611-312	611-312	1	—	—
KM100A1-A7	76-81	1	611-312	611-312	1	—	—
KV100A7	1976	1	611-312	611-312	1	—	—
KX100B5/B6	95-96	1	610-342	610-127	1	—	610-127J
KX100B7	1997	1	610-438	610-127	1	—	610-127J
KX100C1/C2/C3	98-00	1	610-438	610-127	1	—	610-127J
KLX100	10-11	1	610-340	610-120	1	—	—
KX100D1-DCF	01-12	1	610-438	610-127	1	—	610-127J
KLX110A1-DCF	02-12	1	611-417	—	1	—	—
C2SS-120 Roadrunner	67-69	1	611-312	611-312	1	—	—
C2TR-120 Roadrunner	67-69	1	611-312	611-312	1	—	—
KD125/A2/A3/A4/A5	75-79	1	611-408	611-409	1	—	—
KE125A3-A10	76-83	1	611-408	611-409	1	—	—
KLX125A1/A2/A3/A6F	03-06	1	611-310	611-310	1	—	—
KLX125B1/B2/B3/B6F	03-06	1	610-351	611-310	1	—	—
KS125/A	74-75	1	611-408	611-409	1	—	—
KX125/A/A3	74-76	1	611-408	611-409	1	—	—
KX125A4/A5/A6/A7	78-81	1	611-408	611-409	1	—	—
KX125B1	1982	1	610-342	611-409	1	—	—
KX125B2/C1/D1	83-85	1	610-425	—	1	610-425J	—
KX125E1/E2/F1	86-88	1	610-425	610-425	1	610-425J	610-425J
KX125G1/H1/H2/J1/J2	89-93	1	610-340	610-432	1	—	—
KX125K1	1994	1	610-161	610-432	1	—	—
KX125K2/K3	95-96	1	610-161	610-144	1	—	—
KX125K4/K5	97-98	1	610-139	610-144	1	610-139J	—
KX125L1/L2	99-00	1	610-139	610-144	1	610-139J	—
KX125L3/L4	01-02	1	610-161	610-144	1	—	—
KX125M1/M2/M3	03-05	1	610-161	610-144	1	—	—
KD175A1/A2/A3/A4	76-79	1	611-408	611-409	1	—	—
KDX175A1/A2/A3	80-82	1	611-408	611-409	1	—	—
KE175B1/B2/B3	76-78	1	611-408	611-411	1	—	611-411NS
KE175D2-D5	80-83	1	611-408	611-416	1	—	—
KDX200A1/A2/A3	83-85	1	611-416	—	1	—	—
KDX200C1/C2/C3	86-88	1	610-425	—	1	610-425J	—
KDX200E1/E2/E3/E4	89-92	1	610-425	610-432	1	610-425J	—
KDX200E5/E6	93-94	1	610-425	610-340	1	610-425J	—
KDX200H1-H11	95-05	1	610-161	610-432	1	—	—
KDX200H6F	2006	1	610-161	610-432	1	—	—

## Kawasaki Dual Sport & Offroad

Model	Year	Qt	Kevlar Front	Kevlar Rear	Qt	Sintered Front	Sintered Rear
KDX220A4-A12	97-05	1	610-161	610-432	1	—	—
KDX250A1/B1/B2	80-82	1	611-411	611-309	1	611-411NS	—
KDX250B3/B4	83-84	1	611-411	611-409	1	611-411NS	—
KDX250D1/D2/D3/D4	91-94	1	610-340	610-432	1	—	—
KE250B1/B2/B3	77-79	1	611-411	611-309	1	611-411NS	—
KL250A1/A1A/A2	78-79	1	611-411	611-309	1	611-411NS	—
KL250A3/A4/A5	80-82	1	611-408	611-416	1	—	—
KL250C1/C2	83-84	1	611-408	611-416	1	—	—
KL250D2-D22 KLR250	85-05	1	610-425	611-416	1	610-425J	—
KL250G Super Sherpa	00-03	1	—	610-425	1	—	610-425J
KLX250A1/A2	79-80	1	611-408	611-409	1	—	—
KLX250D2/D3/D4	94-96	1	610-161	610-432	1	—	—
KT250 Trials	75-76	1	611-408	611-409	1	—	—
KX250	1974	1	611-409	611-309	1	—	—
KX250A/A3	75-76	1	611-411	611-309	1	611-411NS	—
KX250A4/A5	78-79	1	611-411	611-309	1	611-411NS	—
KX250A6/A7	80-81	1	611-411	611-309	1	611-411NS	—
KX250B1	1982	1	610-342	611-409	1	—	—
KX250C1/C2/D1	83-85	1	610-425	611-409	1	610-425J	—
KX250D2	1986	1	610-425	610-425	1	610-425J	610-425J
KX250E1/F1	87-88	1	610-428	610-425	1	610-428J	610-425J
KX250G1-J2	89-93	1	610-340	610-432	1	—	—
KX250K1	1994	1	610-161	610-432	1	—	—
KX250K2/K3	95-96	1	610-161	610-144	1	—	—
KX250K4/K5/L1/L2	97-00	1	610-139	610-144	1	610-139	—
KX250L3/L4/M1/M2	01-04	1	610-161	610-144	1	—	—
KX250R1/RCF	05-08	1	610-161	610-144	1	—	—
KX250N1/N2 KX250F	04-05	1	610-161	—	1	—	—
KX250T6F-YCF	06-12	1	610-161	—	1	—	—
KLX300A2-A10	97-05	1	610-161	610-144	1	—	—
KLX300A6F/A7F	06-07	1	610-161	610-144	1	—	—
KDX400A1/A2	79-80	1	611-411	611-309	1	611-411NS	—
KLX400A1 Dual Sport	2003	1	610-161	610-144	1	—	—
KLX400B1 KLX400R	2003	1	610-161	610-144	1	—	—
KX400/A2	75-76	1	611-411	611-309	1	611-411NS	—
KDX420B1	1981	1	611-411	611-309	1	611-411NS	—
KX420A1/A2	80-81	1	611-411	611-309	1	611-411NS	—
KDX450A1	1982	1	611-411	611-309	1	611-411NS	—
KX450D6F-EBF	06-12	1	610-161	—	1	—	—
KX500A1/A2/B1	83-85	1	610-425	611-409	1	610-425J	—
KX500B2	1986	1	610-425	610-425	1	610-425J	610-425J
KX500C1/D1	87-88	1	610-428	610-425	1	610-428J	610-425J
KX500E1-E5	89-93	1	610-340	610-432	1	—	—
KX500E6/E7	94-95	1	610-161	610-432	1	—	—
KX500E8-E16	96-04	1	610-161	610-144	1	—	—
KL600A1 KLR600	1984	1	610-425	611-409	1	610-425J	—
KL600/B1/B2 KLR600	85-86	1	610-425	611-409	1	610-425J	—
KL650A1-A19 KLR650	87-05	1	610-428	610-425	1	610-428J	610-425J
KL650A6F/A7F KLR650	06-07	1	610-428	610-425	1	610-428J	610-425J
KL650 E8F-ECF KLR	08-12	1	610-340	610-250	1	610-340J	—
KL650B Tengai KLR650	90-91	1	610-427	610-425	1	610-427J	610-425J
KLX650A KLX650R	93-95	1	610-161	610-432	1	—	—
KLX650C Dual Sport	93-96	1	610-161	610-432	1	—	—
KLX650D1 KLX650R	1996	1	610-161	610-144	1	—	—

## Suzuki Street

FA50T-M Shuttle	80-91	1	611-323	611-323	1	—	—
FS50T/X	80-81	1	611-323	611-323	1	—	—
FZ50N/T/X/Z/D Shuttle	79-83	1	611-322	611-322	1	—	—
OR50N	1979	1	611-312	611-312	1	—	—
OR50T	1980	1	611-310	611-310	1	—	—
RB50H (GSXR50)	1987	1	610-342	611-312	1	—	—
TS75M/A/B Colt	75-77	1	611-312	611-312	1	—	—
RV90J/K/L/M/A/B Rover	72-77	1	611-312	611-312	1	—	—
A100A/B Gopher	76-77	1	611-302	611-312	1	—	—
SP100D	1983	1	611-311	611-310	1	—	—
TC100K/L/M Blazer	73-75	1	611-312	611-302	1	—	—
TC100A/B Blazer	76-77	1	611-312	611-312	1	—	—

## Suzuki Street

Model	Year	QtKevlar Front	Kevlar Rear	QtSintered Front	Sintered Rear
TS100K/L/M Honcho	73-75	1 611-312	611-302	1	—
TS100A/B Honcho	76-77	1 611-302	611-302	1	—
TS100C/N/T/X	78-81	1 611-302	611-302	1	—
GN125Z/D	82-83	1 611-302	611-302	1	—
GN125EM-EV	91-97	1 610-425	611-302	1 610-425J	—
RV125K Tracker	1973	1 611-312	611-302	1	—
RV125L/M/A/B Tracker	74-77	1 611-302	611-302	1	—
SP125Z/D Dual Sport	82-83	1 611-302	611-302	1	—
SP125G/H/J Dual Sport	86-88	1 610-120	611-302	1	—
TC125K Prospector	1973	1 611-312	611-302	1	—
TC125L-B Prospector	74-77	1 611-302	611-302	1	—
TS125R/J/K Duster	71-73	1 611-312	611-302	1	—
TS125L/M/A/B Duster	74-77	1 611-302	611-302	1	—
TS125C/N/T/X	78-81	1 611-302	611-302	1	—
GT185K Adventurer	1973	1	611-302	1	—
GT185L-B Adventurer	74-77	1 610-301	611-302	1	—
TC185L/M/A/B Ranger	74-77	1 611-302	611-302	1	—
TS185R/J/K Sierra	71-73	1 611-312	611-302	1	—
TS185L/M/A Sierra	74-76	1 611-302	611-302	1	—
TS185B/C/N/T/X	77-81	1 611-302	611-302	1	—
SP200G/H/J	86-88	1 610-120	611-302	1	—
DR250SL-SES Dual	90-95	1 610-340	610-432	1 610-340J	—
GN250Z/D	82-83	1	611-302	1	—
GN250F	1985	1	611-302	1	—
GN250J	1988	1	611-302	1	—
GS250TT/TX	80-81	1 610-322	611-308	1	—
GS300LZ/LD	82-83	1 611-304	611-308	1	—
GS300LF	1985	1	611-308	1	—
GN400T/X/TXX	80-81	1 610-322	611-308	1	—
GN400TX/TZ	81-82	1 610-322	611-308	1	—
GS400B/C	77-78	1 610-318	611-305	1	—
GS400XB/XC	77-78	1	611-305	1	—
GSF400M/N/P Bandit	91-93	2 610-344/2	610-327	2	—
GS425N	1979	1 610-318	611-304	1	—
GS425EN	1979	1 610-318	611-308	1	—
GS450ET/EX/EZ/ED	80-83	1 610-322	611-308	1	—
GS450GAZ/GAD	82-83	1 610-322	611-308	1	—
GS450GAF Automatic	1985	1 610-322	611-308	1	—
GS450LT/LX/LZ/LD	80-83	1 610-322	611-308	1	—
GS450LF/LG/L/LJ	85-88	1 610-322	611-308	1	—
GS450ST/SX	80-81	1 610-322	611-308	1	—
GS450TX/TZ	81-82	1 610-322	611-308	1	—
GS500EK-ES	89-95	1 610-427	610-327	1 610-427J	—
GS500ET-EK2	96-02	1	610-327	2	—
GS500FK4-LO	04-10	2	610-327	2	—
GSX-R750T/V/W/X	96-99	2 610-349	610-327	2 610-349J	—
GSX-R750Y/K1/K2/K3	00-03	2 610-344	610-327	2 610-344J	—
GSX-R750K4/K5	04-05	2 VD-355	VD-436	2	—
GSX-R750K6-LO	06-10	2 VD-355	VD-359	2	—
GT750J Lemans	1972	1	611-306	1	—
GT750K/B Lemans	73-77	2 610-301	611-306	2	—
VS750GLP Intruder	88-91	1 610-331	611-321	1	—
VL800K1-K4 Volusia	01-04	1	611-321	1	—
VS800GLN-GLK4	92-04	1 610-331	611-321	1	—
Intruder					
VS800GLK5-K9	05-09	1 610-331	611-321	1	—
Boulevard S50					
VX800L/M/N/P	90-93	1 610-427	610-345/2	1 610-427J	—
VZ800V-K4 Marauder	97-04	1	611-321	1	—
VZ800K5-L0	05-10	1	611-321	1	—
Boulevard M50					
GS850GN	1979	2 610-318	610-306	2	610-306J
GS850GT/GX/GZ/GD	80-83	2 610-322	610-306	2	610-306J
GS850GLT-GLD	80-83	2 610-322	610-306	2	610-306J
XN85D Turbo	1983	1 610-324	610-306	1	610-306J
RF900RR/RS	94-95	2 610-343	610-350	2 610-343J	—
RF900RT/RV	96-97	2 610-343/2	610-349	2	—
RF900RZS	1995	2 610-343	610-350	2 610-343J	—
DL1000K2-K9 V-Storm	02-09	1 610-352-L	610-163	1	—
		1	R	1	—

## Suzuki Street

Model	Year	QtKevlar Front	Kevlar Rear	QtSintered Front	Sintered Rear
GS1000C/EC/N/EN	78-79	2	610-306	1	610-306J
GS1000ET	1980	2 610-324	610-306	2	610-306J
GS1000GT/GLT/GX/GLX	80-81	2 610-322	610-306	2	610-306J
GS1000LN	1979	2	610-306	2	610-306J
GS1000SN	1979	2	610-306	2	610-306J
GS1000ST	1980	2 610-324	610-306	2	610-306J
GS1000SZ Katana	1982	2 610-324	610-306	2	610-306J
GSX-R1000K1/K2	01-02	2 610-349	—	2	—
GSX-R1000K3	2003	2	—	2	—
GSX-R1000K4/K5/K6	04-06	2	VD-355JL	VD-436/2	2
GSX-R1000 K7-K8	07-08	2	VD-355JL	VD-359JL	2
GSX-R1000 K9-L1	09-11	2	VD-355JL	VD-174JL	2
GSX-R1000ZK4 Limited	2004	2	—	2	—
SV1000K3-K7 V-Storm	03-07	2 610-344	610-163	2 610-344J	—
SV1000SK3-SK7	03-07	2 610-344	610-163	2 610-344J	—
TL1000RW-RK3	98-03	2 610-349	610-327	2	—
TL1000SV-SK1	97-01	2 610-344	610-327	2 610-344J	—
GS1100ET-ESD	80-83	2 610-324	610-306	2	610-306J
GS1100GZ-GLD	82-83	2 610-322	610-306	2	610-306J
GS1100GKZ-GKD	82-84	2 610-322	610-306	2	610-306J
GS1100LT	1980	2 610-324	610-306	2	610-306J
GS1100SD Katana	1983	2 610-324	610-306	2	610-306J
GSX1100FJ-FP Katana	88-93	2 610-345	610-331	2	—
GSX1100GM/GN/GP	91-93	2	610-345/2	2 610-427J	—
GSX-R1100G/H/J	86-88	2 610-331	610-327	2	—
GSX-R1100K/L/M/N	89-92	2 610-343	610-327	2 610-343J	—
GSX-R1100WP-WW	93-98	2 610-349	610-327	2	—
GS1150ES3-ESG	83-86	2 610-331	610-331	2	—
GSF1200S Bandit	96-99	2 610-343/2	610-327	2	—
GSF1200SV-W Bandit	97-98	2 610-343/2	610-327	2	—
GSF1200Y-SK5	00-05	2 610-349	610-327	2	—
GSF1200SK6 Bandit	2006	2 610-344	610-163	2 610-344J	—
GV1200GL Madura	85-86	2 610-322	610-306	2	610-306J
GSX1300RK-K7	99-07	2 610-349	610-327	2	—
Hayabusa					
GSX1300K8-L1	08-11	2	VD-355JL	VD-359JL	1
Hayabusa					
GV1400GC Cavalcade	86-87	2 610-345/2	610-331	2	—
GV1400GDG Cavalcade	1986	2 610-331	610-331	2	—
(up to frame number 103764)					
GV1400GDG Cavalcade	1986	2 610-331	—	2	—
(from frame number 103765)					
GV1400GDH/GDJ	87-88	2 610-345/2	610-331	2	—
Cavalcade					
GV1400GTG Cavalcade	1986	2 610-331	610-331	2	—
GV1400GTH Cavalcade	1987	2 610-345/2	610-331	2	—
VS1400GLFH Intruder	1987	2 610-331	610-331	2	—
VS1400GLPH-GLPK4	87-04	2 610-331	610-331	2	—
Intruder					
VS1400 Boulevard S83	05-09	2 610-331	610-331	2	—
VL1500W-K1	98-01	2 610-331	610-331	2	—
Intruder 1500 LC					
VL1500K2/K3/K4	02-04	1 610-352-L	—	1	—
Intruder 1500 LC		1	R	—	—
VL1500LC	05-09	1 610-352-L	—	1	—
Boulevard C90		1	R	1	—
VL1500LC	2006	1 610-352-L	—	1	—
Boulevard C90T		1	R	1	—
VZ1600K4 Marauder	2004	2 610-349	—	2	610-435/2J
1600 Boulevard M95	2005	2	—	2	610-435/2J
1800 Boulevard M109R	06-11	2	—	2	610-435/2J

## Suzuki ATV

ALT50D/E	83-84	—	611-323	—	—
LT50E/F/G/H	84-87	—	611-313	—	611-313NS
LT-A50K2-K5	02-05	2 611-310	611-323	2	—
LT80H-Y Quadrunner	87-00	2 611-323	611-314	2	—
LT80K1-K6 Quad Sport	01-06	2 611-323	611-314	2	—
ALT125D	1983	—	611-315	—	—
ALT125E/F/G	84-86	—	611-309	—	—

# Brake Pads & Brake Shoes

## Suzuki ATV

Model	Year	Qt Kevlar Front	Kevlar Rear	Qt Sintered Front	Sintered Rear
LT125D	1983	—	<b>611-315</b>	—	—
LT125E/F/G/H	84-87	—	<b>611-309</b>	—	—
LT160EK/EL/EM/EN	89-92	2 <b>611-328</b>	<b>611-309</b>	2	—
LT-F160M/N/P/R/S/T	91-96	2 <b>611-328</b>	<b>611-309</b>	2	—
ALT185E/F	84-85	—	<b>611-309</b>	—	—
LT185E/F/G/H	84-87	—	<b>611-309</b>	—	—
LT230EH-EP Quad	87-93	2 <b>610-332</b>	<b>610-127/2</b>	2	<b>610-127/2J</b>
LT230GEF/GEG	85-86	2 <b>611-320</b>	<b>611-309</b>	2	—
LT230SF	1985	2 <b>610-332</b>	<b>610-127</b>	2	<b>610-127J</b>
LT230SG/SH/SJ	86-88	2 <b>610-332</b>	<b>610-127/2</b>	2	<b>610-127/2J</b>
LT-F230G/H	86-87	2 <b>611-320</b>	<b>611-309</b>	2	—
LT250EFF/EFG	85-86	2 <b>611-320</b>	<b>611-306</b>	2	—
LT250R Quadracracer	85-86	2 <b>610-332</b>	<b>610-127</b>	2	<b>610-127J</b>
LT250R Quadracracer	87-92	2 <b>610-332</b>	<b>610-341</b>	2	<b>610-341J</b>
LT250SK/SL	89-90	2 <b>610-332</b>	<b>610-127</b>	2	<b>610-127J</b>
LT-4WDH-WDW	87-98	2 <b>611-327</b>	<b>611-329</b>	2	—
Quadrunner 4WD					
LT-F250K2-K7	02-06	2 <b>610-120</b>	—	2	—
Ozark 250 2WD					
LT-F250 K7-L2	07-12	2 <b>VD-127/2</b>	<b>VB-332</b>	—	—
Ozark 250					
LT-F250J-K1	88-01	2 <b>611-327</b>	<b>611-329</b>	2	—
Quadrunner 250					
LT-F250FX/FY/FK1/FK2	99-02	2 <b>611-327</b>	<b>611-329</b>	2	—
LT-Z250K4-K9	04-09	2 <b>610-127/2</b>	—	2	<b>610-127/2J</b>
LT300E Quadrunner	87-89	2 <b>611-320</b>	<b>611-306</b>	2	—
LT-F300F King Quad	99-01	2 <b>611-326</b>	<b>611-306</b>	2	—
LT-F300FK2 King Quad	2002	1 <b>610-250-L</b>	<b>611-306</b>	1	—
		1 <b>610-340-R</b>	—	1	—
LT-F4WDXM-WDXW King Quad	91-98	2 <b>611-326</b>	<b>611-306</b>	2	—
LT-A400K2/K3/K4	02-04	2 <b>610-120</b>	<b>611-308</b>	2	—
Eiger Auto 2WD					
LT-F400K2/K3/K4	02-04	2 <b>610-120</b>	<b>611-308</b>	2	—
Eiger Manual 2WD					
LT-F400FK2-FK5	02-05	2 <b>610-120</b>	<b>611-308</b>	2	—
Eiger Auto 4WD					
LT-F400FK6	06-07	2 <b>610-127/2</b>	<b>611-308</b>	2	<b>610-127/2J</b>
Eiger Auto 4WD					
LT-F400F K8-L0	08-10	R —	<b>VB-308</b>	—	—
		L —	—	—	—
LT-Z400K3/K4/K5/K6	03-06	2 <b>610-127/2</b>	<b>610-341</b>	2	<b>610-127/2J</b>
LT-R450K6-L0 Quadracracer	06-10	1 <b>610-250-L</b>	<b>611-306</b>	1	—
		1 <b>610-340-R</b>	—	1	—
LT500R Quadracracer	87-90	2 <b>610-332</b>	<b>610-341</b>	2	—
LT-A500FY/FK1	00-01	1 <b>610-250-L</b>	<b>611-306</b>	1	—
		1 <b>610-340-R</b>	—	1	—
LT-A500FK2 Vinson	2002	2 <b>610-120</b>	—	2	—
LT-A500FK3 Vinson	2003	2 <b>610-120</b>	—	2	—
LT-A500FK4-FK7	04-07	2 <b>610-127/2</b>	—	2	<b>610-127/2J</b>
Vinson 4WD					
LT-F500FW-FK2	98-02	1 <b>610-250-L</b>	<b>611-306</b>	1	—
		1 <b>610-340-R</b>	—	1	—
LT-F500FK3 Quad	2003	2 <b>610-120</b>	—	2	—
LT-F500 K4-K7	04-07	2 <b>610-127/2</b>	—	2	<b>610-127/2J</b>
LT-A700XK5-K7 King Quad	05-07	R —	—	1	—
		L —	—	1	—
LT-V700FK4/FK5	04-05	1 —	—	1	—

## Suzuki Dual Sport & Offroad

JR50C-K6	78-06	1 <b>611-313</b>	<b>611-313</b>	1	<b>611-313NS</b>	<b>611-313NS</b>
OR50N	1979	1 <b>611-312</b>	<b>611-312</b>	1	—	—
OR50T	1980	1 <b>611-310</b>	<b>611-310</b>	1	—	—
RM50C/N/T	78-80	1 <b>611-312</b>	<b>611-312</b>	1	—	—
RM60X/Z	81-82	1 <b>611-310</b>	<b>611-310</b>	1	—	—
RM60K3	2003	1 <b>611-417</b>	<b>611-417</b>	1	<b>611-417NS</b>	<b>611-417NS</b>
RM60N/T	79-80	1 <b>611-312</b>	<b>611-312</b>	1	—	—
RM60X/Z/D	81-83	1 <b>611-310</b>	<b>611-310</b>	1	—	—
RM65K3/K4/K5	03-05	1 —	<b>610-120</b>	1	—	—

## Suzuki Dual Sport & Offroad

Model	Year	Qt Kevlar Front	Kevlar Rear	Qt Sintered Front	Sintered Rear
TM75L/M/A	74-76	1 <b>611-312</b>	<b>611-312</b>	1	—
TS75M/A/B Colt	75-77	1 <b>611-312</b>	<b>611-312</b>	1	—
DS80C/N	78-79	1 <b>611-312</b>	<b>611-312</b>	1	—
DS80 T-Y	80-00	1 <b>611-310</b>	<b>611-310</b>	1	—
JR80 K1-K7	01-07	1 <b>611-310</b>	<b>611-310</b>	1	—
RM80B/C/N	77-79	1 <b>611-312</b>	<b>611-312</b>	1	—
RM80T/X	80-81	1 <b>611-310</b>	<b>611-310</b>	1	—
RM80Z/D/E/F	82-85	1 —	<b>611-226</b>	1	<b>611-226NS</b>
RM80G/H/J/K	86-89	1 <b>610-342</b>	<b>611-226</b>	1	<b>611-226NS</b>
RM80L/M/N/P/R/S	90-95	1 <b>610-342</b>	<b>610-342/2</b>	1	—
RM80T/V/W/X/Y/K1	96-01	1 <b>610-351</b>	<b>610-342/2</b>	1	—
RM85K2/K3/K4	02-04	1 <b>610-351</b>	<b>610-342/2</b>	1	—
RM85K5-L2	05-12	1 <b>610-438</b>	—	1	—
RM85LK2/LK3/LK4	02-04	1 <b>610-351</b>	<b>610-342/2</b>	1	—
RM85LK5-L2	05-12	1 <b>610-438</b>	—	1	—
RV90J/K/L/M/A/B Rover	72-77	1 <b>611-312</b>	<b>611-312</b>	1	—
A100A/B Gopher	76-77	1 <b>611-302</b>	<b>611-312</b>	1	—
RM100K3	2003	1 <b>610-438</b>	<b>610-127/2</b>	1	<b>610-127/2J</b>
DR-Z110K3	2003	1 <b>611-417</b>	<b>611-312</b>	1	—
DR-Z110K4/K5	04-05	1 <b>611-417</b>	—	1	—
DR125Z/D/E	82-84	1 <b>611-302</b>	<b>611-302</b>	1	—
DR125G/H/J	86-88	1 <b>610-120</b>	<b>611-302</b>	1	—
DR125SER/SES/SET	94-96	1 <b>610-120</b>	<b>611-302</b>	1	—
DR-Z125K3-K9	03-09	1 <b>611-310</b>	<b>611-310</b>	1	—
DR-Z125LK3-K9	03-09	1 <b>610-351</b>	<b>611-310</b>	1	—
RM125M/A/B/C	75-78	1 <b>611-302</b>	<b>611-302</b>	1	—
RM125N/T	79-80	1 <b>611-302</b>	<b>611-309</b>	1	—
RM125X/Z/D	81-83	1 <b>611-314</b>	<b>611-316</b>	1	<b>611-316NS</b>
RM125E	1984	1 —	<b>611-316</b>	1	<b>611-316NS</b>
RM125F/G	85-86	1 <b>610-329</b>	<b>611-316</b>	1	<b>611-316NS</b>
RM125H	1987	1 <b>610-340</b>	<b>611-316</b>	1	<b>611-316NS</b>
RM125J	1988	1 <b>610-340</b>	<b>610-127</b>	1	<b>610-127J</b>
RM125K/L	89-90	1 <b>610-340</b>	<b>610-432</b>	1	—
RM125M/N	91-92	1 <b>610-340</b>	<b>610-432/2</b>	1	—
RM125P	1993	1 <b>610-340</b>	<b>610-332</b>	1	<b>610-332J</b>
RM125R/S	94-95	1 <b>610-340</b>	<b>610-432/2</b>	1	—
RM125T-K1-K5	96-05	1 <b>610-161</b>	<b>610-144</b>	1	—
RM125K6	2006	1 <b>610-161</b>	<b>610-144/2</b>	1	—
RM125K7-K9	07-09	1 <b>610-161</b>	<b>610-144</b>	1	—
RM125K Tracker	1973	1 <b>611-312</b>	<b>611-302</b>	1	—
RV125L/M/A/B Tracker	74-77	1 <b>611-302</b>	<b>611-302</b>	1	—
SP125Z/D Dual Sport	82-83	1 <b>611-302</b>	<b>611-302</b>	1	—
SP125G/H/J Dual Sport	86-88	1 <b>610-120</b>	<b>611-302</b>	1	—
TC125L-B Prospector	74-77	1 <b>611-302</b>	<b>611-302</b>	1	—
TM125K/L/M	73-75	1 <b>611-312</b>	<b>611-302</b>	1	—
TS125R/J/K Duster	71-73	1 <b>611-312</b>	<b>611-302</b>	1	—
TS125L/M/A/B Duster	74-77	1 <b>611-302</b>	<b>611-302</b>	1	—
TS125C/N/T/X	78-81	1 <b>611-302</b>	<b>611-302</b>	1	—
PE175C/N	78-79	1 <b>611-302</b>	<b>611-302</b>	1	—
PE175T/X	80-81	1 <b>611-302</b>	—	1	—
PE175Z/D/E	82-84	1 <b>611-314</b>	—	1	—
RS175T/X/Z	80-82	1 <b>611-302</b>	<b>611-311</b>	1	<b>611-302NS</b>
DS185C/N/T	78-80	1 <b>611-302</b>	<b>611-302</b>	1	<b>611-302NS</b>
TC185L/M/A/B	74-77	1 <b>611-302</b>	<b>611-302</b>	1	<b>611-302NS</b>
TS185R/J/K	71-73	1 <b>611-312</b>	<b>611-302</b>	1	<b>611-312NS</b>
TS185L/M/A Sierra	74-76	1 <b>611-302</b>	<b>611-302</b>	1	<b>611-302NS</b>
TS185B/C/N/T/X	77-81	1 <b>611-302</b>	<b>611-302</b>	1	<b>611-302NS</b>
DR200G/H/J	86-88	1 <b>610-120</b>	<b>611-302</b>	1	—
DR200S P-K9 Dual	93-09	1 <b>610-120</b>	<b>611-302</b>	1	—
SP200G/H/J	86-88	1 <b>610-120</b>	<b>611-302</b>	1	—
DR250Z/D	82-83	1 <b>611-302</b>	<b>611-302</b>	1	<b>611-302NS</b>
DR250F	1985	1 <b>610-120</b>	<b>611-302</b>	1	—
DR250L/M/N/P/R/S	90-95	1 <b>610-340</b>	<b>610-432</b>	1	<b>610-340J</b>
DR250SL-SES Dual	90-95	1 <b>610-340</b>	<b>610-432</b>	1	<b>610-340J</b>
DR-Z250K1-K7	01-07	1 <b>610-161</b>	<b>610-432/2</b>	1	<b>610-161J</b>
DS250T	1980	1 <b>611-309</b>	<b>611-309</b>	1	<b>611-309NS</b>
PE250B/C/N	77-79	1 <b>611-309</b>	<b>611-309</b>	1	<b>611-309NS</b>
PE250T/X	80-81	1 <b>610-312</b>	<b>611-309</b>	1	<b>610-312NS</b>
RM250A/B/C/C2	76-78	1 <b>611-302</b>	<b>611-309</b>	1	<b>611-302NS</b>
RM250N/T	79-80	1 <b>611-309</b>	<b>611-318</b>	1	<b>611-309NS</b>





## Suzuki Dual Sport & Offroad

Model	Year	Qt Kevlar Front	Kevlar Rear	Qt Sintered Front	Sintered Rear
RM250X/Z	81-82	1 611-315	611-316	1	
RM250D/E	83-84	1	611-316	1	
RM250F/G	85-86	1 610-329	611-316	1	
RM250H/J	87-88	1 610-340	610-127	1	
RM250K/L	89-90	1 610-340	610-432	1	
RM250M/N	91-92	1 610-340	610-332	1	
RM250P/R/S	93-95	1 610-340	610-432/2	1	
RM250T-K5	96-05	1 610-161	610-144	1	
RM250K6	2006	1 610-161	610-144/2	1	
RM250K7-K9	07-09	1 610-161	610-144	1	
RMX250K/L	89-90	1 610-340	610-432	1	
RMX250M/N/P/R/S	91-95	1 610-340	610-432/2	1	
RMX250T/V/W	96-98	1 610-161		1	
RM-Z250K4-K9	04-09	1 610-161		1	
RM-Z250 L0-L2	10-12	1 610-161		1	
RS250T/X	80-81	1 611-302	611-309	1	
SP250Z/D	82-83	1 611-318	611-302	1	
SP250F	1985	1 610-120	611-302	1	
TM250J/K/L/M	72-75	1 611-302	611-309	1	
TS250R-B Savage	71-77	1 611-309	611-309	1	
TS250C/N/T/X	78-81	1 611-309	611-309	1	
DR350L/M	90-91	1 610-340	610-432	1	
DR350N/P/R/S/T	92-96	1 610-340	610-432/2	1	
DR350V/W/X	97-99	1 610-161	610-432/2	1	
DR350SL-SEV Dual	90-97	1 610-340	610-432	1	
DR350SEW/SEX Dual	98-99	1 610-161	610-432	1	
DR370C/N	78-79	1 611-302	611-309	1	
RM370A/B	76-77	1 611-302	611-309	1	
SP370C/N/T	78-80	1 611-309	611-309	1	
DR400T	1980	1 611-302	611-309	1	
DR-Z400EY-EK7	00-07	1 610-161	610-144	1	
DR-Z400Y-K4	00-04	1 610-161	610-144	1	
DR-Z400S Y-L2 Dual	00-12	1 610-161	610-144	1	
DR-Z400SM K5-K9	05-09	1 610-161	610-144	1	
Supermotard					
PE400T/X	80-81	1 611-309	611-309	1	
RM400C	1978	1 611-302	611-309	1	
RM400N/T	79-80	1 611-309	611-318	1	611-318NS
SP400T	1980	1 611-309	611-309	1	
TM400R/J/K/L/M	71-75	1 611-309	611-309	1	
TS400J/-B Apache	72-77	1 611-309	611-309	1	
RM-Z450K5/K6/K7	05-07	1 610-161		1	
RM-Z450 K8-L2	08-12	1 610-161		1	
RM-X450 K5-K7	05-07	1 610-161		1	
RM-X450 K8-L1	08-11	1 610-161		1	
RM465X/Z	81-82	1 611-315	611-314	1	
DR500X/Z/D	81-83	1 611-302	611-309	1	
RM500D/E	83-84	1	611-314	1	
SP500X/Z/D	81-83	1 611-309	611-309	1	
SP600F	1985	1 610-329/2	611-302	1	
DR650SL-SES Dual	90-95	1 610-347	610-348	1	
DR650SE T-L1 Dual	96-11	1 610-161	610-432	1	

## Triumph

Daytona 600	03-04	2 610-343	610-163	2 610-343J	
Speedfour 600	02-05	2 610-343		2 610-343J	
TT600	00-03	2 610-343		2 610-343J	
Daytona 650	2005	2 610-343	610-163	2 610-343J	
Bonneville 800	01-05	1 610-156/3		1	
Bonneville America	02-05	1 610-156/3	610-156/3	1	
Bonneville T100	02-08	1 610-156	610-340	1	
Centennial					
Speedmaster 800	05-09	2 610-156/3	610-340	2	
Thruxton 900	2004	1 610-156/3		1	
Adventurer	96-01	1 610-156	610-156	1	
T509 Speed Triple	97-01	2 610-343		2 610-343J	
Thunderbird 900	95-03	1 610-156	610-156/2	1	610-156/2J
Adventurer 900	96-00	1 610-156/3	610-156/3	1	
Daytona 900	95-96	2 610-343		2 610-343J	

## Triumph

Model	Year	Qt Kevlar Front	Kevlar Rear	Qt Sintered Front	Sintered Rear
Daytona 955i	99-00	2 610-343		2 610-343J	
Legend TT	99-01	2 610-156/3	610-156/3	2	
Sprint 900	95-97	2 610-343		2 610-343J	
Sprint Executive	1998	2 610-343		2 610-343J	
Sprint SS	97-98	2 610-343		2 610-343J	
Super Daytona III	95-96	1 610-258		1	
Thruxton	04-11	1 610-156/3		1	
Thunderbird	00-03	1 610-156/3	610-156/3	1	
Thunderbird Sport 900	98-00	1 610-156/3	610-156/3	1	
Thunderbird Sport 900	2003	2 610-156/3	610-156/3	2	
Thunderbird Two-Tone	1996	1 610-156/3	610-156/3	1	
Tiger	1993	1 610-340-L		1	
		1 610-250-R		1	
Tiger 900	95-96	1 610-340-L		1	
		1 610-250-R		1	
Tiger 900	97-98	2 610-156/3	610-156/3	2	
Tiger 900	99-00	2 610-156	610-156/2	2	610-156/2J
Trident 900	95-98	1 610-340-L		1	
		1 610-250-R		1	
Trophy 900	95-01	2 610-343		2 610-343J	
Daytona T595	97-00	2 610-343	610-340	2 610-343J	
Daytona 955i	01-05	2 610-343		2 610-343J	
Speed Triple (Carb model)	94-97	2 610-343		2 610-343J	
Speed Triple	98-04	2 610-343		2 610-343J	
Sprint RS	99-02	2 610-343		2 610-343J	
Sprint RS	03-04	2 610-343		2 610-343J	
Sprint RS (single side swingarm)	99-04	2 610-343		2 610-343J	
Sprint ST	99-09	2 610-343		2 610-343J	
Sprint ST ABS	10-11	2 610-343	VD-340/2	2	
Tiger 955	99-05	2 610-156/3	610-156/3	2	
Speed Triple	2005	2 610-443		2	
Sprint ST	05-09	2 610-343		2 610-343J	
Daytona 1200	95-97	2 610-343		2 610-343J	
Daytona 1200 SP	1999	2 610-343		2 610-343J	
Trophy 1200	95-03	2 610-343		2 610-343J	
Rocket III	2004	2 610-343		2 610-343J	

## Yamaha Street

CA50K/L/N/S Riva 50	83-86	1 611-224	611-226	1	611-226NS
CE50S/T Jog	86-87	1 611-224	611-226	1	611-226NS
CG50T/U/W/A/B Jog	87-91	1 611-224	611-226	1	611-226NS
CV50L Riva 50	1984	1 611-229	611-229	1	
CW50W Zuma	1989	1 611-229	611-229	1	
CW50TA Zuma	1990	1 611-229	611-229	1	
CW50TJ Zuma II	1997	1 611-229	611-229	1	
CY50D-N Jog	92-01	1 611-226	611-229	1	611-226NS
DT50U/W/A	88-90	1 611-229	611-229	1	
LB50PE-PJ Chappy	78-82	1 611-212	611-212	1	
LC50G/H Champ	80-81	1 611-226	611-226	1	
MJ50J Towny	1982	1 611-224	611-224	1	
QT50F-T Yamahopper	79-87	1 611-224	611-224	1	
RX50K/L/MK	83-84	1 610-228	611-212	1	610-228J
SH50T-N Razz	87-01	1 611-224	611-226	1	611-226NS
SH50MT/MU/MW Razz	87-89	1 611-224	611-226	1	611-226NS
SH50MD	1991	1 611-224	611-226	1	611-226NS
YSR50T/U/W/A/B/D	87-92	1 610-239	611-239	1	611-229 611-229NS
BW80S/T/U Big Wheel	86-88	1 611-226	611-226	1	611-226NS 611-226NS
BW80A Big Wheel	1990	1 611-226	611-226	1	611-226NS 611-226NS
CV80K/L/N/S/T Riva	83-87	1 611-229	611-229	1	
DT80H/J	81-82	1 611-212	611-212	1	
DT80K	1983	1 611-229	611-229	1	
GT80A/B/C	74-76	1 611-212	611-212	1	
GT80E/F/G	78-80	1 611-212	611-212	1	
DT100A-J	74-82	1 611-212	611-212	1	
DT100K	1983	1 611-229	611-229	1	
RS100B/C	75-76	1 611-212	611-212	1	
DT125A/B/C Enduro	74-76	1 611-223	611-223	1	
DT125E/F/G/H Enduro	78-82	1 611-223	611-223	1	

# Brake Pads & Brake Shoes

VINTAGE

INTAKE

ENGINE

SUSPENSION

CONTROL

ELECTRICAL

CHEMICAL

TOOLS

WATERCRAFT

## Yamaha Street

Model	Year	Qt	Kevlar Front	Kevlar Rear	Qt	Sintered Front	Sintered Rear
RD125B/C	75-76	1	611-237	611-223	1	—	—
XC125N/NC-D Riva	85-92	1	—	611-223	1	—	—
XC125E-N Riva	93-01	1	—	611-239	1	—	611-239NS
XT125J/K/KC Dual	82-83	1	611-223	611-229	1	—	—
DT175A/B/C Enduro	74-76	1	611-223	611-223	1	—	—
DT175E/F/G/H Enduro	78-81	1	611-223	611-223	1	—	—
XC180DN/DNC Riva	1985	1	—	611-228	1	—	—
XC180K/KC-N/NC Riva	83-85	1	—	611-228	1	—	—
XC180Z Riva	84-85	1	—	611-228	1	—	—
SR185H/J Exciter	81-82	1	611-223	611-229	1	—	—
BW200N/S Big Wheel	85-87	1	611-229	611-229	1	—	—
BW200E Big Wheel	86-88	1	611-229	611-229	1	—	—
RD200A/B	74-75	1	611-206	611-228	1	—	—
RD200C	1976	1	—	611-228	1	—	—
XC200T-B Riva	87-91	1	—	611-228	1	—	—
XC200ZT-ZA Riva	87-90	1	—	611-228	1	—	—
XT200J/K/KC Dual	82-83	1	611-223	611-229	1	—	—
XT225D/DC-M/MC	92-00	1	610-239	611-229	1	—	—
XT225N/NC-V/V/C	01-06	1	610-236	611-229	1	—	—
DT250A Enduro	1974	1	611-228	611-228	1	—	—
DT250B/C/D/E/F	75-79	1	611-220	611-228	1	—	—
SR250G/H/J Exciter	80-82	1	611-220	611-223	1	—	—
SR250TH Exciter	1981	1	611-220	611-223	1	—	—
SRX250T/TC	1987	1	610-240	611-228	1	—	—
XT250G/H/J	80-82	1	611-223	611-223	1	—	—
XT250K/KC/L/LC Dual	83-84	1	611-223	611-223	1	—	—
XV250U/UC-A/AC	88-90	1	610-235	611-223	1	—	—
XV250G/GC/H/HK/KC	95-98	1	610-260	611-239	1	—	611-239NS
Route 66							
XV250L/LC Virago 250	1999	1	610-260	611-239	1	—	—
XV250P X-P	08-12	1	610-260	611-239	1	—	—
BW350T/U	87-88	1	611-229	611-229	1	—	—
RD350A/B	73-75	1	610-204	611-225	1	—	—
RZ350L/LC/N/NC	84-85	1	610-235	610-236	1	—	—
XT350N/NC-A/AC Dual	85-90	1	610-239	611-223	1	—	—
XT350B/BC-M/MC Dual	91-00	1	610-239	611-239	1	—	611-239NS
XS360C/D/2D	76-77	1	610-205	611-231	1	—	—
DT400B/C/D/E	75-78	1	611-220	611-228	1	—	—
FZR400U/SUC/W/SWC	88-89	2	610-236	610-240	2	—	—
FZR400A/SAC	1990	2	610-242/2	610-240	2	—	—
RD400C/D/E	76-78	1	610-204	610-204	1	—	—
RD400F	1979	1	610-215	610-215	1	—	—
XS400D/E/F (mag)	77-79	1	610-205	610-205	1	—	—
XS400E/2F (spoke)	78-79	1	611-206	611-231	1	—	—
XS400G/H Special	80-81	1	611-206	611-231	1	—	—
XS400J/K Maxim	82-83	1	610-235	611-231	1	—	—
XS400R/RK Seca	82-83	1	610-235	611-231	1	—	—
XS400SG/SH Special	80-81	1	610-215	611-231	1	—	—
XS400SJ Special	1982	1	611-206	611-231	1	—	—
SR500E/F	78-79	1	610-205	610-205	1	—	—
SR500G/H	80-81	1	610-205	611-228	1	—	611-228NS
TX500/A	73-74	1	610-204	611-227	1	—	611-227NS
XS500B	1975	1	610-204	611-227	1	—	611-227NS
XS500C/D/E	76-78	1	610-205	610-205	1	—	—
XT500C-H Dual Sport	76-81	1	611-220	611-228	1	611-220NS	611-228NS
XV500K Virago	1983	1	610-235	611-227	1	—	611-227NS
XV535T/TC/U Virago	87-88	1	610-246	611-230	1	—	611-230NS
XV535A/AC Virago	1990	1	610-246	611-230	1	—	611-230NS
XV535E/EC-L/LC	93-99	1	610-246	611-230	1	—	611-230NS
XV535SF/SFC-SJ/SJC	94-97	1	610-246	611-230	1	—	611-230NS
XJ550H/J/K Maxim	81-83	1	610-228	611-227	1	610-228J	611-227NS
XJ550RH/RJ/RK Seca	81-83	1	610-228	611-231	1	610-228J	—
XT550J/K Dual Sport	82-83	1	611-228	611-228	1	—	—
XZ550R/RK Vision	82-83	2	610-235	611-227	2	—	611-227NS
FJ600L/LC/N/NC	84-85	2	610-236	610-236	2	—	—
FZ600S/SC/T/TC/U/UC	86-88	2	610-236	610-240	2	—	—
FZ600T/TC/V/V/C FZ6	05-06	2	610-260	—	2	—	—
FZ600 W-Y FZ6	07-09	2	610-248	VD-163	2	—	—
FZ600S FZ6	04-05	2	610-260	—	2	—	—
FZR600W/WC/AC	89-90	2	610-236	610-236	2	—	—
FZR600R	90-99	2	610-251	610-236	2	610-251J	—
SRX600S/SC	1986	2	610-240	610-240	2	—	—
XJ600S Seca II	92-98	2	610-255	610-240	2	—	—

## Yamaha Street

Model	Year	Qt	Kevlar Front	Kevlar Rear	Qt	Sintered Front	Sintered Rear
XT600L/LC-W/WC	84-89	1	610-235	611-228	1	—	—
XT600E Dual Sport	90-95	1	610-252	611-239	1	—	611-239NS
YX600 Radian	86-90	2	610-236	611-227	2	—	611-227NS
YZF600R	95-96	2	610-251	610-236	2	610-251J	—
YZF600R	97-07	2	610-248	610-236	2	610-248J	—
YZF-R6L/LC-P/PC	99-02	2	610-248	—	2	610-248J	—
YZF-R6R/RC-B	03-12	2	610-248	VD-163/2	2	610-248J	SD-163/2
YZF-R6SN/SNC	2001	2	610-248	—	2	610-248J	—
Champions Limited Edition							
YZF-R6SPV/SPVC	2006	2	610-248	VD-163/2	2	610-248J	SD-163/2
50th Anniversary							
YZF-R6S R-B	03-12	2	610-248	VD-163/2	2	610-248J	SD-163/2
YZF-R6SV/Y/YC	06-09	2	610-248	VD-163/2	2	610-248J	SD-163/2
XJ650G/H/J/K Maxim	80-83	1	610-216	611-227	1	—	611-227NS
XJ650LH Midnight	1981	1	610-216	611-227	1	—	611-227NS
XJ650LJ/LK Turbo	82-83	1	610-216	611-227	1	—	611-227NS
XJ650RJ Seca	1982	2	610-205	611-230	2	—	611-230NS
XS1/XS1B-650	70-71	1	—	611-225	1	—	—
XS2-650	1972	1	610-204	611-225	1	—	—
TX650/A	73-74	1	610-204	611-225	1	—	—
XS650B/C	75-76	1	610-204	611-225	1	—	—
XS650D/E/F/2F	77-79	1	610-205	611-225	1	—	—
XS650G/H Special II	80-81	1	610-205	611-225	1	—	—
XS650S Special	78-80	1	610-205	610-205	1	—	—
XS650SH Special	1981	1	610-205	611-225	1	—	—
XS650SJ/SK	82-83	1	610-205	611-225	1	—	—
Heritage Special							
XVS650AK-Z	98-10	1	610-255	611-230	1	—	611-230NS
V-Star Classic							
XVS650 R/RC-Z/ZC	03-10	1	610-255	611-230	1	—	611-230NS
V-Star Silverado							
XVS650 V-Star Custom	98-04	1	610-255	611-230	1	—	611-230NS
XVS650S/SC-AB/ACB	04-11	1	610-255	611-230	1	—	611-230NS
V-Star Midnight Custom							
FZ700T/TC	1987	2	610-236	610-236	2	—	—
FZX700 Fazer	86-87	2	610-236	610-236	2	—	—
XS750D/2D/E/F	77-79	2	610-205	610-205	2	—	—
XJ700 Maxim	85-86	2	610-236	611-230	2	—	611-230NS
XJ700X Maxim X	85-86	2	610-236	611-230	2	—	611-230NS
XV700CS/CSC/CT/CTC	86-87	2	610-236	611-230	2	—	611-230NS
XV700L/LC-T/TC Virago	84-87	2	610-236	611-230	2	—	611-230NS
FZ750N/S/SC	85-86	2	610-236	610-236	2	—	—
FZ750U/UC	1988	2	610-236	610-236	2	—	—
FZR750RT/RU	87-88	2	610-242/2	610-236	2	—	—
TX750/A	73-74	1	610-204	611-230	1	—	611-230NS
XJ750J/K Maxim	82-83	2	610-235	611-230	2	—	611-230NS
XJ750MK Midnight	1983	2	610-235	611-230	2	—	611-230NS
XJ750RH/RJ/RK Seca	81-83	2	610-228	611-230	2	610-228J	611-230NS
XS750SE/SF Special	78-79	1	610-216-L	610-205	1	—	—
		1	610-215-R	—	1	—	—
XV750H/J/K Virago	81-83	1	610-216	611-227	1	—	611-227NS
XV750MK Midnight	1983	1	610-216	611-227	1	—	611-227NS
XV750U/UC-J/JC	88-97	2	610-236	611-230	2	—	611-230NS
Virago							
XV750H1/H1C/J1/J1C	96-97	2	610-236	611-230	2	—	611-230NS
YZF750RF/RFC	1994	2	610-258	610-236	2	—	—
YZF750R	96-98	2	610-258	610-236	2	—	—
TDM850D/DC/E/EC	92-93	2	610-242/2	610-236	2	—	—
XS850G/H	80-81	2	610-205	610-205	2	—	—
XS850L/LH Midnight	80-81	1	610-216-L	610-215	1	—	—
		1	610-215-R	—	1	—	—
XS850SG/SH Special	80-81	1	610-216-L	610-215	1	—	—
		1	610-215-R	—	1	—	—
XJ900RK Seca	1983	2	610-236	610-236	2	—	—
XV920J Virago	1982	2	610-228	611-230	2	610-228J	611-230NS
XV920K Virago	1983	1	610-216	611-230	1	—	611-230NS
XV920MK Midnight	1983	1	610-216	611-230	1	—	611-230NS
XV920RH/RJ	81-82	2	610-205	611-230	2	—	611-230NS
FZR1000T/TC/U/UC	87-88	2	610-242/2	610-236	2	—	—
FZR1000W/WC/A/AC	89-90	2	610-251	610-236	2	610-251J	—
FZR1000B/BC-E/EC	91-93	2	610-257	610-236	2	—	—
FZR1000F/FC/G/GC	94-95	2	610-258	610-236	2	—	—
FZS1000 FZ1	01-05	2	610-248	—	2	610-248J	—



# Brake Pads & Brake Shoes

## Yamaha Street

Model	Year	Qt	Kevlar Front	Kevlar Rear	Qt	Sintered Front	Sintered Rear
FZS1000V/V C FZ1	06-09	2	<b>610-248</b>	<b>VD-163/2</b>	2	<b>610-248J</b>	—
FZS1000SP FZ1	2003	2	<b>610-248</b>	—	2	<b>610-248J</b>	—
GTS1000A	93-94	2	<b>610-259</b>	<b>610-236</b>	2	—	—
XV1000L/LC/N/NC	84-85	2	<b>610-236</b>	<b>610-236</b>	2	—	—
YZF1000R/J/RJC	1997	2	<b>610-248</b>	<b>610-236</b>	2	<b>610-248J</b>	—
YZF-R1K/KC-N/NC	98-01	2	<b>610-248</b>	—	2	<b>610-248J</b>	—
YZF-R1P/PC/R/RC	02-03	2	<b>610-248</b>	—	2	<b>610-248J</b>	—
YZF-R1S/SC-V/V C	04-06	2	<b>610-248</b>	<b>VD-163/2</b>	2	<b>610-248J</b>	—
YZF-R1 W-B	07-12	2	<b>VD-277</b>	<b>VD-163/2</b>	2	—	—
YZF-R1LEV/LEVC	2006	2	<b>610-248</b>	<b>VD-163/2</b>	2	<b>610-248J</b>	—
Limited Edition							
YZF-R1SPV/SPVC	2006	2	<b>610-248</b>	<b>VD-163/2</b>	2	<b>610-248J</b>	—
50th Anniversary Edition							
YZF-R1SN/SNC	2001	2	<b>610-248</b>	—	2	<b>610-248J</b>	—
Champions Limited Edition							
FJ1100L/LC/N/NC	84-85	2	<b>610-236</b>	<b>610-236</b>	2	—	—
XJ1100J Maxim	1982	2	<b>610-228</b>	<b>610-215</b>	2	<b>610-228J</b>	—
XS1100E/F/G/H	78-81	2	<b>610-205</b>	<b>610-205</b>	2	—	—
XS1100LG Midnight	1980	1	<b>610-216-L610-205</b>	—	1	—	—
		1	<b>610-215-R</b>	—	1	—	—
XS1100LH Midnight	1981	2	<b>610-228</b>	<b>610-215</b>	2	<b>610-228J</b>	—
XS1100S Special	79-81	1	<b>610-216-L610-205</b>	—	1	—	—
		1	<b>610-215-R</b>	—	1	—	—
XV1100S/UC-L/LC	86-99	2	<b>610-236</b>	<b>611-230</b>	2	—	<b>611-230NS</b>
XV1100S Virago S	96-98	2	<b>610-236</b>	<b>611-230</b>	2	—	<b>611-230NS</b>
XVS1100L/LC-T	99-09	2	<b>610-260</b>	<b>610-236</b>	2	—	—
V-Star 1100 Custom							
XVS1100 V-Star Classic	00-06	2	<b>610-260</b>	<b>610-236</b>	2	—	—
XVS1100S/SC-Y/YC	04-09	2	<b>610-260</b>	<b>610-236</b>	2	—	—
V-Star Silverado							
FJ1200S/SC/T/T C	86-87	2	<b>610-236</b>	<b>610-236</b>	2	—	—
FJ1200W/W-D/DC	89-92	2	<b>610-242/2610-236</b>	—	2	—	—
FJ1200A (ABS)	92-93	2	<b>610-242/2610-236</b>	—	2	—	—
VMX12 V-Max	85-86	2	<b>610-236</b>	<b>610-236</b>	2	—	—
VMX12 V-Max	88-92	2	<b>610-236</b>	<b>610-236</b>	2	—	—
VMX12V-Max E/EC-W1C	93-07	2	<b>610-251</b>	<b>610-236</b>	2	<b>610-251J</b>	—
XVZ12TK/L/KC2	83-84	2	<b>610-236</b>	<b>610-236</b>	2	—	—
Venture							
XVZ12TDK	1983	2	<b>610-236</b>	<b>610-236</b>	2	—	—
Venture Royale							
XVZ12DL/DKC2/DN	84-85	2	<b>610-236</b>	<b>610-236</b>	2	—	—
Venture Royale							
FJR1300R/RC-T/T C	03-05	2	<b>610-248</b>	—	2	<b>610-248J</b>	—
FJR1300AS (ABS)	04-05	2	<b>610-248</b>	—	2	<b>610-248J</b>	—
FJR1300 AV-B	06-12	2	<b>VD-353JL</b>	<b>VD-269/2</b>	2	—	—
XVZ13T/TC/U/UC	87-88	2	<b>610-242</b>	<b>610-242</b>	2	—	—
Venture							
XVZ13D Royale	86-93	2	<b>610-242</b>	<b>610-242</b>	2	—	—
XVZ1300A Royal Star	96-98	2	<b>610-242</b>	<b>610-242</b>	2	—	—
XVZ1300A Boulevard	99-01	2	<b>610-242</b>	<b>610-242</b>	2	—	—
XVZ1300A	96-00	2	<b>610-242</b>	<b>610-242</b>	2	—	—
Royal Star Tour Classic							
XVZ1300C	2005	2	<b>610-255</b>	<b>610-242</b>	2	—	—
Royal Star Tour Deluxe							
XVZ1300CT T/TC-Y	05-09	2	<b>610-255</b>	<b>610-242</b>	2	—	—
Royal Star Tour Deluxe							
XVZ1300CTM V/V C-W/MC	06-07	2	<b>610-255</b>	<b>610-242</b>	2	—	—
Royal Star Midnight Tour Deluxe							
XVZ1300LT	97-01	2	<b>610-242</b>	<b>610-242</b>	2	—	—
Royal Star Tour Deluxe							
XVZ1300TFSMC	2000	2	<b>610-255</b>	<b>610-242</b>	2	—	—
Royal Star Venture MM							
XVZ1300TF	99-09	2	<b>610-255</b>	<b>610-242</b>	2	—	—
Royal Star Venture							
XVZ1300TF S	08-12	2	<b>610-255</b>	<b>610-242</b>	2	—	—
Royal Star Midnight Venture							
XV1600A Road Star	99-03	2	<b>610-255</b>	<b>610-242</b>	2	—	—
XV1600AT	99-03	2	<b>610-255</b>	<b>610-242</b>	2	—	—
Road Star Silverado							
XV1600ASM/ASMC	2000	2	<b>610-255</b>	<b>610-242</b>	2	—	—
Road Star MM Limited							
XV1600AS Midnight	01-03	2	<b>610-255</b>	<b>610-242</b>	2	—	—

## Yamaha Street

Model	Year	Qt	Kevlar Front	Kevlar Rear	Qt	Sintered Front	Sintered Rear
XV1600ALER/ALERC	2003	2	<b>610-255</b>	<b>610-242</b>	2	—	—
Road Star Limited Edition							
XXV1600ATL	2003	2	<b>610-255</b>	<b>610-242</b>	2	—	—
Road Star Silverado Limited Edition							
XV1700A S Road Star	08-12	2	<b>610-248</b>	<b>610-242</b>	2	<b>610-248J</b>	—
XV1700AM	04-07	2	<b>610-248</b>	<b>610-242</b>	2	<b>610-248J</b>	—
Road Star Midnight							
XV1700AT	04-10	2	<b>610-248</b>	<b>610-242</b>	2	<b>610-248J</b>	—
Road Star Silverado							
XV1700ATM	04-07	2	<b>610-248</b>	<b>610-242</b>	2	<b>610-248J</b>	—
Road Star Midnight Silverado							
XV1700AW Road Star	05-09	2	<b>610-248</b>	<b>610-242</b>	2	<b>610-248J</b>	—
XV1700PC	02-06	2	<b>610-248</b>	—	2	<b>610-248J</b>	—
Road Star Warrior							
XV1700PCM	06-09	2	<b>610-248</b>	—	2	<b>610-248J</b>	—
Road Star Midnight Warrior							
XV1700PCR/PCRC	2003	2	<b>610-248</b>	—	2	<b>610-248J</b>	—
Road Star Warrior							
XV1900CTMV/C-A	06-11	2	<b>610-248</b>	—	2	<b>610-248J</b>	—
Stratoliner Midnight							
XV1900CTSVC-Z	06-10	2	<b>610-248</b>	—	2	<b>610-248J</b>	—
Stratoliner S							
XV1900CT A-V	06-11	2	<b>610-248</b>	—	2	<b>610-248J</b>	—
Stratoliner							
XV1900MV-Y	06-09	2	<b>610-248</b>	—	2	<b>610-248J</b>	—
Roadliner Midnight							
XV1900SV-Z	06-10	2	<b>610-248</b>	—	2	<b>610-248J</b>	—
Roadliner S							
XV1900V/V C	2006	2	<b>610-248</b>	—	2	<b>610-248J</b>	—
Roadliner							

## Yamaha ATV

YFM50S-Y Raptor	04-08	2	<b>611-229</b>	<b>611-239</b>	2	—	<b>611-239NS</b>
YFM50S-T Raptor 50	04-05	2	<b>611-229</b>	<b>611-239</b>	2	—	<b>611-239NS</b>
YF60S	1986	—	<b>611-229</b>	—	—	—	—
YT60L/N Tri-Zinger	84-85	—	<b>611-229</b>	—	—	—	—
YFM80N/S/T/U Moto-4	85-88	2	—	<b>611-223</b>	2	—	—
YFM80D-N Badger	92-01	2	<b>611-229</b>	<b>611-239</b>	2	—	<b>611-239NS</b>
YFM80GT/GV Grizzly	05-06	2	<b>611-229</b>	<b>611-239</b>	2	—	<b>611-239NS</b>
YFM80GHV-Y Grizzly	06-08	2	<b>611-229</b>	<b>611-239</b>	2	—	<b>611-239NS</b>
YFM80RT-Y Raptor	05-08	2	<b>611-229</b>	<b>611-239</b>	2	—	<b>611-239NS</b>
YFM80W Raptor	02-04	2	<b>611-229</b>	<b>611-239</b>	2	—	<b>611-239NS</b>
YFM100T-/B Champ	87-91	2	<b>611-229</b>	<b>611-223</b>	2	—	—
YFA1Breeze	89-91	2	<b>611-229</b>	<b>611-223</b>	2	—	—
YFA1 Breeze	92-04	2	<b>611-229</b>	<b>611-239</b>	2	—	<b>611-239NS</b>
YFM125S Grizzly 125	2004	2	<b>611-229</b>	<b>611-239</b>	2	—	<b>611-239NS</b>
YFM125GT-V Grizzly	05-12	2	<b>611-229</b>	<b>611-239</b>	2	—	<b>611-239NS</b>
YFM125GHT-Y Grizzly	05-08	2	<b>611-229</b>	<b>611-239</b>	2	—	<b>611-239NS</b>
YT125G-N Tri-Moto	80-85	2	—	<b>610-222</b>	2	—	—
YT175J/K Tri-Moto	82-83	2	<b>611-229</b>	<b>610-234</b>	2	—	<b>610-234J</b>
YFM200N Moto 4	1985	2	<b>611-229</b>	<b>610-234</b>	2	—	<b>610-234J</b>
YFM200DX Moto 4	86-89	2	<b>611-229</b>	<b>610-234</b>	2	—	<b>610-234J</b>
YFS200U-P Blaster	88-02	2	<b>611-229</b>	<b>610-261</b>	2	—	—
YFS200R/S/T/V Blaster	03-06	2	<b>610-120</b>	<b>610-127/2</b>	2	—	<b>610-127/2</b>
YTM200K/L/N Tri-Moto	83-85	2	<b>611-229</b>	<b>610-234</b>	2	—	<b>610-234J</b>
YTM200E Tri-Moto	83-85	2	<b>611-229</b>	<b>610-234</b>	2	—	<b>610-234J</b>
YFM225S/T/U Moto-4	86-88	2	<b>611-229</b>	<b>610-234</b>	2	—	<b>610-234J</b>
YTM225DR Tri-Moto	85-86	2	<b>611-229</b>	<b>610-234</b>	2	—	<b>610-234J</b>
YTM225DX Tri-Moto	83-85	2	<b>611-229</b>	<b>610-234</b>	2	—	<b>610-234J</b>
YFB250D/E/F	92-94	2	<b>611-229</b>	<b>611-220</b>	2	—	<b>611-220NS</b>
Timberwolf							
YFB250G/H/J	95-97	2	<b>611-220</b>	<b>611-220</b>	2	<b>611-220NS</b>	<b>611-220NS</b>
YFB250FW	94-00	2	<b>611-220</b>	<b>611-220</b>	2	<b>611-220NS</b>	<b>611-220NS</b>
Timberwolf 4WD							
YFB250UH/UJ/UK	96-98	2	<b>611-220</b>	<b>611-220</b>	2	<b>611-220NS</b>	<b>611-220NS</b>
Timberwolf 2WD							
YFM250M/MC	2000	2	<b>611-220</b>	<b>611-220</b>	2	<b>611-220NS</b>	<b>611-220NS</b>
Beartracker							
YFM250W/A/B Moto-4	89-91	2	<b>611-220</b>	<b>610-234</b>	2	<b>611-220NS</b>	<b>610-234J</b>
YFM250BT/BV Bruin	05-06	2	<b>610-120</b>	—	2	—	—
YFM250B W-Z	07-10	2	<b>610-120</b>	<b>VD-245</b>	2	—	—

# Brake Pads & Brake Shoes

## Yamaha ATV

Model	Year	Qt	Kevlar Front	Kevlar Rear	Qt	Sintered Front	Sintered Rear
YFM250XHN/XHP	01-02	2	610-120	611-220	2	—	611-220NS
Beartracker Real Tree							
YFM250X Beartracker	1999	2	611-220	611-220	2	611-220NS	611-220NS
YFM250X Beartracker	00-04	2	610-120	611-220	2	—	611-220NS
YTZ250N/S Tri-Z	85-86	2	610-239	610-239	2	—	—
YFM350ER Moto-4	87-88	2	611-229	610-234	2	—	610-234J
YFM350ER Moto-4	89-90	2	611-220	610-234	2	—	610-234J
YFM350ER Moto-4	92-95	2	611-220	610-234	2	—	610-234J
YFM350FAS Bruin 350	04-06	2	610-120	—	2	—	—
YFM350FAHS	2004	2	610-120	—	2	—	—
Bruin 350 Auto 4x4 Hardwood Camo							
YFM350FH Wolverine	1999	2	610-120	611-231	2	—	—
YFM350FW Big Bear	87-88	2	611-238	611-238	2	611-238NS	611-238NS
YFM350FW Big Bear	89-95	2	611-240	610-234	2	611-240NS	610-234J
YFM350FW Big Bear	96-97	2	611-240	611-231	2	611-240NS	—
YFM350FWB Big Bear	97-98	2	611-240	611-231	2	611-240NS	—
YFM350FWB Big Bear	1999	2	610-120	611-231	2	—	—
YFM350FX Wolverine	02-03	2	610-120	610-127/2	2	—	610-127/2J
YFM350R Raptor 350	05-09	2	610-127/2	610-127/2	2	610-127/2J	610-127/2J
YFM350RS Raptor SE	05-06	2	610-127/2	610-127/2	2	610-127/2J	610-127/2J
YFM350XT/XU Warrior	87-88	2	610-239	610-127/2	2	—	610-127/2J
YFM350X Warrior	89-01	2	610-120	610-127/2	2	—	610-127/2J
YFM350X Warrior	02-04	2	610-127/2	610-127/2	2	610-127/2J	610-127/2J
YFZ350T/U/W Banshee	87-89	2	610-239	610-127/2	2	—	610-127/2J
YFZ350A-N Banshee	90-01	2	610-120	610-127/2	2	—	610-127/2J
YFZ350P-V Banshee	02-06	2	610-127/2	610-127/2	2	610-127/2J	610-127/2
YFM400AKodiak 2WD	00-01	2	610-120	610-266	2	—	—
YFM400AKodiak 2WD	03-04	2	610-120	—	2	—	—
YFM400FAH Kodiak	2000	2	610-120	610-266	2	—	—
4WD Hunter							
YFM400FAHN	2001	2	610-120	610-266	2	—	—
Kodiak 4WD Real Tree Hunter							
YFM400FAHR	2003	2	610-120	610-266	2	—	—
Kodiak 400 4x4 Camo Hardwood							
YFM400FAHS	2004	2	610-120	—	2	—	—
Kodiak 400 4x4 Camo Hardwood							
YFM400FAHT/FAHV	05-06	2	610-120	610-266	2	—	—
Kodiak 400 4WD Hunter							
YFM400FA Kodiak 4WD	00-02	2	610-120	610-266	2	—	—
YFM400FAR/FAS	2003	2	610-120	611-231	2	—	—
Kodiak 4WD							
YFM400FAS	2004	2	610-120	—	2	—	—
Kodiak 400 4x4							
YFM400FAT/FAV	05-06	2	610-120	610-266	2	—	—
Kodiak 400 4x4							
YFM400FHM	2001	2	610-120	611-231	2	—	—
Big Bear Buckmaster 4WD							
YFM400FHN	2002	2	610-120	611-231	2	—	—
Big Bear 4WD Real Tree X-Tra							
YFM400FHAP	2002	2	610-120	610-266	2	—	—
Kodiak 4WD Hunter							
YFM400FHP	2002	2	610-120	611-231	2	—	—
Big Bear 4WD Real Tree Hunter							
YFM400F Big Bear	00-04	2	610-120	611-231	2	—	—
YFM400FT/FV	05-06	2	610-120	—	2	—	—
Big Bear 400 4x4							
YFM400FWBL/FWBLC	1999	2	610-120	611-231	2	—	—
Kodiak 4WD							
YFM400FWE-FWK	93-98	2	611-240	611-231	2	611-240NS	—
Kodiak 4WD							
YFM400FWR	2003	2	610-120	611-231	2	—	—
Big Bear 4WD							
YFM400HN/HP	01-02	2	610-120	611-231	2	—	—
Big Bear 2WD Real Tree Hunter							
YFM400NM/NMC	2000	2	610-120	611-231	2	—	—
Big Bear 2WD							
YFM400N/P	01-02	2	610-120	611-231	2	—	—
Big Bear 400 2WD							
YFM400NR	2003	2	610-120	611-231	2	—	—
Big Bear 400 2WD							
YFM400S Big Bear 2WD	2004	2	610-120	611-231	2	—	—
YFM450F Kodiak 4WD	03-06	2	610-120	610-266	2	—	—

## Yamaha ATV

Model	Year	Qt	Kevlar Front	Kevlar Rear	Qt	Sintered Front	Sintered Rear
YFM450FAH Kodiak	2003	2	610-120	610-266	2	—	—
450 Real Tree							
YFM450FAHS	2004	2	610-120	610-266	2	—	—
Kodiak 450 Auto 4x4 Hardwoods							
YFM450FAHT/FAHV	05-06	2	610-120	610-266	2	—	—
Kodiak 450 4WD Hunter							
YFM450FSET	2005	2	610-120	610-266	2	—	—
Kodiak 450 4WD Black Carbon							
YFM450FASEV	2006	2	610-120	610-266	2	—	—
Kodiak 450 4WD Special Edition							
YFM450FXV	2006	2	610-120	610-266	2	—	—
Wolverine 450 4x4 Sport							
YFZ450S/T	04-05	1	610-340-L	610-127/2	1	610-340J-L	610-127/2J
		1	610-250-R	—	1	—	—
YFZ450V-Y	06-08	1	610-340-L	—	1	—	—
		1	610-250-R	—	1	—	—
YFZ450BB V-W	06-07	1	610-340-L	—	1	—	—
		1	610-250-R	—	1	—	—
YYFZ450LES	2004	1	610-340-L	610-127/2	1	—	610-127/2J
		1	610-250-R	—	1	—	—
YFZ450SET	2005	2	610-250	610-127/2	2	—	610-127/2J
Special Edition							
YFZ450SPV	2006	1	610-340-L	—	1	—	—
Special Edition		1	610-250-R	—	1	—	—
YFM600FWA Grizzly	98-00	2	610-127/2	611-231	2	610-127/2J	—
YFM600FWH	2000	2	610-127/2	611-231	2	610-127/2J	—
Grizzly Realtree							
YFM600FHN	2001	2	610-127/2	611-231	2	610-127/2J	—
Grizzly Realtree Hunter							
YFM600FM/FMC/FN	00-01	2	610-127/2	611-231	2	610-127/2J	—
Grizzly							
YFM660FP/FR/FS	02-04	2	610-127/2	—	2	610-127/2J	—
Grizzly 660							
YFM660FPS Grizzly	2002	2	610-127/2	—	2	610-127/2	—
YFM660FAHT	2005	2	610-127/2	—	2	610-127/2	—
Grizzly 660 Hunter							
YFM660FAHDV	2006	2	610-127/2	—	2	610-127/2	—
Grizzly 660 Ducks Unlimited							
YFM660 FG W-X	07-08	2	610-127/2	—	2	610-127/2	—
Grizzly 660 Hunter							
YFM660FAHWT	2005	2	610-127/2	—	2	610-127/2	—
Grizzly 660 Hunter Wetland							
YFM660FH P-S	02-04	2	610-127/2	—	2	610-127/2	—
Grizzly 660 SE							
YFM660FAT/FAV	02-06	2	610-127/2	—	2	610-127/2	—
Grizzly 660							
YFM660FHP	2002	2	610-127/2	—	2	610-127/2	—
Grizzly 660 Hunter Edition							
YFM660FHRWL	2003	2	610-127/2	—	2	610-127/2	—
Grizzly Wetlands Hunter Edition							
YFM660FHRH	2003	2	610-127/2	—	2	610-127/2	—
Grizzly Realtree Hardwood Hunter							
YFM660FHS	2004	2	610-127/2	—	2	610-127/2	—
Grizzly 660 Hardwoods Hunter Camo							
YFM660FHSWL	2004	2	610-127/2	—	2	610-127/2	—
Grizzly 660 Auto 4x4 Wetland							
YFM660FLES Grizzly	2004	2	610-127/2	—	2	610-127/2	—
YFM660FRGY	2003	2	610-127/2	—	2	610-127/2	—
Grizzly 660 4x4 Metallic Titanium							
YFM660R Raptor 660R	01-02	2	610-127/2	610-127/2	2	610-127/2J	610-127/2J
YFM660R Raptor 660R	03-05	2	610-127/2	610-127/2	2	610-127/2J	610-127/2J
YFM660RPB	2002	2	610-127/2	610-127/2	2	610-127/2J	610-127/2J
Raptor 660R Limited Edition Black							
YFM660RLER	2003	2	610-127/2	610-127/2	2	610-127/2J	610-127/2J
Raptor 660R Limited Edition Black							
YFM660RLES	2004	2	610-127/2	610-127/2	2	610-127/2J	610-127/2J
Raptor 660R Limited Edition Black							
YFM660RS Raptor SE	2005	2	610-127/2	610-127/2	2	610-127/2J	610-127/2J
YFM700R V-X Raptor	06-09	1	610-340-L	—	1	—	—
		1	610-250-R	—	1	—	—
YFM700RSP V-W Raptor	06-07	1	610-340-L	—	1	—	—
		1	610-250-R	—	1	—	—



# Brake Pads & Brake Shoes

## Yamaha Dual Sport & Offroad

Model	Year	Qt	Kevlar		Sintered		
			Front	Rear	Front	Rear	
DT50U/W/A LC	88-90	1	611-229	611-229	1	---	---
PW50A-B Y-Zinger	90-12	1	611-224	611-224	1	---	---
TT-R50 V-B	06-12	1	611-134	611-134	1	---	---
YZ50G	1980	1	611-226	611-226	1	611-226NS	611-226NS
YZ60H/J/K	81-83	1	611-226	611-226	1	611-226NS	611-226NS
BW80S/T/U Big Wheel	86-88	1	611-226	611-226	1	611-226NS	611-226NS
BW80A Big Wheel	1990	1	611-226	611-226	1	611-226NS	611-226NS
DT80H/J	81-82	1	611-212	611-212	1	---	---
DT80K	1983	1	611-229	611-229	1	---	---
GT80A/B/C	74-76	1	611-212	611-212	1	---	---
GT80E/F/G	78-80	1	611-212	611-212	1	---	---
GTMX-80A/B/C/D/E/F	74-79	1	611-212	611-212	1	---	---
MX80G/H/J	80-82	1	611-212	611-212	1	---	---
PW80D-V Y-Zinger	92-06	1	611-226	611-229	1	611-226NS	---
TY80A/B Trials	74-75	1	611-226	611-212	1	611-226NS	---
YZ80A/B/C/D/E/F	74-79	1	611-226	611-212	1	611-226NS	---
YZ80G/H/J/K/L/N	80-85	1	611-226	611-226	1	611-226NS	611-226NS
YZ80S/T/U/W/A/B/D1	86-92	1	610-244	611-226	1	---	611-226NS
YZ80E1-N1	93-01	1	610-244	610-127	1	---	610-127J
YZ85P/R/S/T/V/W1	02-06	1	610-244	610-127	1	---	610-127J
TT-R90M/MC/N/P/R/S/T	00-05	1	611-226	611-229	1	611-226NS	---
TT-R90ER-EW	03-07	1	611-226	611-229	1	611-226NS	---
DT100A-J	74-82	1	611-212	611-212	1	---	---
DT100K	1983	1	611-229	611-229	1	---	---
MX100A/B	74-75	1	611-212	611-212	1	---	---
MX100F/G/H/J	79-81	1	611-212	611-212	1	---	---
MX100K	1983	1	611-229	611-229	1	---	---
RT100A-M	91-00	1	611-229	611-229	1	---	---
YZ100C/D	76-77	1	611-219	611-223	1	---	---
YZ100E/F/G/H	78-81	1	611-212	611-223	1	---	---
YZ100J/K	82-83	1	611-229	611-223	1	---	---
DT125A/B/C Enduro	74-76	1	611-223	611-223	1	---	---
DT125E/F/G/H Enduro	78-82	1	611-223	611-223	1	---	---
T125G/H	80-81	1	611-212	611-223	1	---	---
MX125A/B	74-75	1	611-223	611-223	1	---	---
MX125C	1976	1	611-219	611-223	1	---	---
TT-R125M/MC	2000	1	611-229	611-229	1	---	---
TT-R125N/P/R/S	01-04	1	610-244	611-229	1	---	---
TT-R125E S-Y	04-09	1	610-244	611-229	1	---	---
TT-R125LN-LV	01-06	1	610-244	611-229	1	---	---
TT-R125LE S-B	04-12	1	610-244	611-229	1	---	---
TT-R125LWM-LER	00-03	1	610-244	611-229	1	---	---
XT125J/K/KC	82-83	1	611-223	611-229	1	---	---
YZ125A/B	74-75	1	611-223	611-212	1	---	---
YZ125C/D/E/F/G/H/J/K	76-83	1	611-219	611-223	1	---	---
YZ125L	1984	1	611-234	611-233	1	---	---
YZ125N/S	85-86	1	610-241	611-233	1	---	---
YZ125T	1987	1	610-241	611-223	1	---	---
YZ125U	1988	1	610-241	610-239	1	---	---
YZ125W	1989	1	610-340	610-127	1	---	610-127J
YZ125A/B/D1/E1	90-93	1	610-340	610-432	1	---	---
YZ125F1/G1/H1/J1	94-97	1	610-340	610-432/2	1	---	---
YZ125K1/L1/M1/N1/P1	98-02	1	610-161	610-144	1	---	---
YZ125R/S1/T1/V/W1	03-07	1	610-161	VD-271JL	1	---	---
YZ125 X-B1	08-12	1	VD-280JL	VD-271JL	1	---	---
DT175A/B/C	74-76	1	611-223	611-223	1	---	---
DT175E/F/G/H	78-81	1	611-223	611-223	1	---	---
IT175D/E/F/G/H/J/K	77-83	1	611-219	611-223	1	---	---
MX175A/B	74-75	1	611-212	611-223	1	---	---
MX175F/G/H	79-81	1	611-212	611-223	1	---	---
TY175B/C Trials	75-76	1	611-212	611-223	1	---	---
RT180A/B	90-91	1	610-245	611-239	1	---	611-239NS
RT180D	1992	1	610-245	611-223	1	---	---
RT180E	1993	1	610-245	611-239	1	---	611-239NS
RT180G/H/J/K	95-98	1	610-239	611-239	1	---	611-239NS
BW200N/S Big Wheel	85-87	1	611-229	611-229	1	---	---
BW200ES/ET/EU	86-88	1	611-229	611-229	1	---	---
IT200L/N	84-85	1	611-233	611-233	1	---	---
IT200S	1986	1	610-241	611-233	1	---	---
TW200 Trailway	87-91	1	611-223	611-229	1	---	---
TW200D/DC-G/GC	92-95	1	611-239	611-239	1	611-239NS	611-239NS
TW200H/HC-L/LC	96-99	1	611-239	611-229	1	611-239NS	---

## Yamaha Dual Sport & Offroad

Model	Year	Qt	Kevlar		Sintered		
			Front	Rear	Front	Rear	
TW200 M/MC-A1/A1C	00-11	1	610-263	611-229	1	---	---
WR200RD	1992	1	610-340	610-340	1	---	---
XT200J/K/KC Dual	82-83	1	611-223	611-229	1	---	---
TT225S/T	86-87	1	610-239	611-229	1	---	---
TT-R225/LC-S/SC	99-04	1	610-239	611-239	1	---	611-239NS
XT225D/DC-M/MC	92-00	1	610-239	611-229	1	---	---
XT225N/NC-W/WC	01-07	1	610-263	611-229	1	---	---
TT-R230T/TC/VVC	05-06	1	610-340	611-239	1	---	611-239NS
DT250A Enduro	1974	1	611-228	611-228	1	---	---
DT250B/C/D/E/F	75-79	1	611-220	611-228	1	---	---
IT250D/E/F/G	77-80	1	611-219	611-220	1	---	---
IT250H/J	81-82	1	611-219	611-228	1	---	---
IT250K	1983	1	611-226	611-228	1	---	---
TT250G/H/J	80-82	1	611-219	611-223	1	---	---
TT-R250/LC-VVC	99-06	1	610-340	610-432/2	1	---	---
TY250A Trials	1974	1	611-212	611-223	1	---	---
TY250C/D Trials	76-77	1	611-212	611-223	1	---	---
WR250ZB/ZD/ZE	91-93	1	610-340	610-340	1	---	---
WR250ZF/ZG/ZH/ZJ	94-97	1	610-340	610-432/2	1	---	---
WR250FN/FP	01-02	1	610-161	610-144	1	---	---
WR250F R-B	03-12	1	610-161	---	1	---	---
XT250G/H/J	80-82	1	611-223	611-223	1	---	---
XT250K/KC/L/LC Dual	83-84	1	611-223	611-223	1	---	---
YZ250A/B/C/D/E/F	74-79	1	611-219	611-220	1	---	---
YZ250G	1980	1	611-219	611-223	1	---	---
YZ250H	1981	1	611-226	611-228	1	---	---
YZ250J/K/L	82-84	1	611-234	611-223	1	---	---
YZ250N/S/T	85-87	1	610-241	611-223	1	---	---
YZ250U	1988	1	610-241	610-239	1	---	---
YZ250W	1989	1	610-340	610-127	1	---	---
YZ250A/B	90-91	1	610-340	610-432	1	---	---
YZ250B/D1/E1	92-93	1	610-340	610-432	1	---	---
YZ250F1/G1/H1/J1	94-97	1	610-340	610-432/2	1	---	---
YZ250M1/N1/P	98-02	1	610-161	610-144	1	---	---
YZ250R/S1/T1/V/W1	03-07	1	610-161	---	1	---	---
YZ250FN/FP	01-02	1	610-161	610-144	1	---	---
YZ250FR/FS/FT/FV	03-07	1	610-161	VD-271JL	1	---	---
YZ250F X-B	08-12	1	VD-280JL	VD-271JL	1	---	---
YZ250WRW	1989	1	610-340	610-127	1	---	610-127J
YZ250WRA	1990	1	610-340	610-432	1	---	---
BW350T/U	87-88	1	611-229	611-229	1	---	---
TT350S/T	86-87	1	610-241	611-223	1	---	---
TY350N/S Trials	85-86	1	611-233	611-212	1	---	---
XT350N/NC-A/AC Dual	85-90	1	610-239	611-223	1	---	---
XT350B/BC-M/MC Dual	91-00	1	610-239	611-239	1	---	611-239NS
DT400B/C/D/E	75-78	1	611-220	611-228	1	---	---
IT400C/D/E/F	76-79	1	611-219	611-220	1	---	---
MX400B	1975	1	611-219	611-220	1	---	---
WR400FK	1998	1	610-161	610-432/2	1	---	---
WR400FL/FM	99-00	1	610-161	610-144	1	---	---
YZ400FK	1998	1	610-161	610-432/2	1	---	---
YZ400FL	1999	1	610-161	610-144	1	---	---
IT425G	1980	1	611-219	611-220	1	---	---
WR426FN/FP	01-02	1	610-161	610-144	1	---	---
YZ426FM/FN/FP	00-02	1	610-161	610-144	1	---	---
WR450F R-A	03-11	1	610-161	---	1	---	---
YZ450F R-W	03-07	1	610-161	---	1	---	---
YZ450F X-B	08-12	1	VD-280JL	VD-271JL	1	---	---
IT465H/J	81-82	1	611-234	611-228	1	---	---
YZ465G	1980	1	611-234	611-220	1	---	---
YZ465H	1981	1	611-234	611-228	1	---	---
IT490K/L	83-84	1	611-234	611-228	1	---	---
YZ490J/K/L	82-84	1	611-234	611-228	1	---	---
YZ490N/S/T/U/W/A	85-90	1	610-241	611-228	1	---	---
WR500ZD/ZE	92-93	1	610-340	610-432	1	---	---
TT500C/D/E/F/G/H	76-81	1	611-219	611-220	1	---	---
XT500C-H Dual	76-81	1	611-220	611-228	1	---	---
XT500J/K Dual Sport	82-83	1	611-228	611-228	1	---	---
TT600K/L	83-84	1	610-234	611-223	1	---	610-234J
TT600N/S	85-86	1	610-239	611-223	1	---	---
XT600L/LC-W/WC Dual	84-89	1	610-235	611-228	1	---	---
XT600E Dual Sport	90-95	1	610-252	611-239	1	---	611-239NS

# Racing Brake Pads



## Vesrah Racing Brake Pads (for Street)

Vesrah R<sub>JL</sub> and SR<sub>JL17</sub> high performance racing pads offer superior stopping power without fade. Sintered metal pads produce increased braking performance with one touch finger braking. Used by Vesrah Suzuki Racing team in USA and many other professional road race teams.

Made in Japan.

## Honda

Model	Year	Hi-Perf. Front R <sub>JL</sub>	Super Racing Front SR <sub>JL17</sub>
CBR600F4 Hurricane	99-00	610-166R <sub>J</sub>	610-166SR <sub>J17</sub>
CBR600F4 (F4i) Hurricane	01-06	610-166/2R <sub>J</sub>	610-166/2SR <sub>J17</sub>
CBR600FR Rossi Champion	2002	610-166/2R <sub>J</sub>	610-166/2SR <sub>J17</sub>
CBR600RR	03-04	610-166/2R <sub>J</sub>	610-166/2SR <sub>J17</sub>
CBR600RR	05-12	610-170R <sub>J</sub>	610-170SR <sub>J17</sub>
RVF750R RC45	1994	610-154R <sub>J</sub>	_____
VFR750R RC30	1990	610-154R <sub>J</sub>	_____
CB900F (919)	02-06	610-154R <sub>J</sub>	_____
CBR900RR	93-95	610-154R <sub>J</sub>	_____
CBR900RR	96-97	610-154/2R <sub>J</sub>	_____
CBR900RR	98-99	610-166R <sub>J</sub>	610-166SR <sub>J17</sub>
CBR929RE	2001	610-166/2R <sub>J</sub>	610-166/2SR <sub>J17</sub>
CBR929RR	00-01	610-166/2R <sub>J</sub>	610-166/2SR <sub>J17</sub>
CBR954RR	02-03	610-166/2R <sub>J</sub>	610-166/2SR <sub>J17</sub>
CBR1000RR	04-11	610-170R <sub>J</sub>	610-170SR <sub>J17</sub>
RVT1000R RC51	00-06	610-166/2R <sub>J</sub>	610-166/2SR <sub>J17</sub>
VTR1000F Super Hawk	98-05	610-154/2R <sub>J</sub>	_____

## Kawasaki

ZX600E1-E10 Ninja ZX-6	93-02	610-344R <sub>J</sub>	610-344SR <sub>J17</sub>
ZX600E11 ZZR600	2003	610-344R <sub>J</sub>	610-344SR <sub>J17</sub>
ZX600F1/F2/F3 Ninja ZX-6R	95-97	610-344R <sub>J</sub>	610-344SR <sub>J17</sub>
ZX600G1/G2 Ninja ZX-6R	98-99	610-349R <sub>J</sub>	610-349SR <sub>J17</sub>
ZX600J1/J2/J3 Ninja ZX-6R	00-02	610-349R <sub>J</sub>	610-349SR <sub>J17</sub>
ZX600J4/J6F/J7F ZZR600	05-08	610-349R <sub>J</sub>	610-349SR <sub>J17</sub>
ZX600K1 Ninja ZX-6RR	2003	610-354R <sub>J</sub>	610-354SR <sub>J17</sub>
ZX600M1 Ninja ZX-6RR	2004	610-354R <sub>J</sub>	610-354SR <sub>J17</sub>
ZX600N1/N6F Ninja ZX-6RR	05-06	610-354R <sub>J</sub>	610-354SR <sub>J17</sub>
ZX636B1/B2 Ninja ZX-6R	03-04	610-354R <sub>J</sub>	610-354SR <sub>J17</sub>
ZX636C1/C6F Ninja ZX-6R	05-06	610-354R <sub>J</sub>	610-354SR <sub>J17</sub>
EX650A6F Ninja 650R	2006	610-352R <sub>J</sub> (LH) 610-435R <sub>J</sub> (RH)	_____
EX650A7F Ninja 650R	2007	610-354R <sub>J</sub>	610-354SR <sub>J17</sub>
ZX750L1/L2/L3 Ninja ZX-7	93-95	610-344R <sub>J</sub>	610-344SR <sub>J17</sub>
ZX750N Ninja ZX-7RR	96-97	610-437R <sub>J</sub>	_____
ZX750P1-P8 Ninja ZX-7R	96-03	610-349R <sub>J</sub>	610-349SR <sub>J17</sub>
ZX900B1/B2/B3 Ninja ZX-9R	94-96	610-344R <sub>J</sub>	610-344SR <sub>J17</sub>
ZX900B4 Ninja ZX-9R	1997	610-349R <sub>J</sub>	610-349SR <sub>J17</sub>
ZX900C1/C2 Ninja ZX-9R	98-99	610-349R <sub>J</sub>	610-349SR <sub>J17</sub>
ZX900E1/E2 Ninja ZX-9R	00-01	610-349R <sub>J</sub>	610-349SR <sub>J17</sub>
ZX1000C1/C2 Ninja ZX-10R	04-05	610-354R <sub>J</sub>	610-354SR <sub>J17</sub>
ZX1000D6F Ninja ZX-10R	04-07	610-354R <sub>J</sub>	610-354SR <sub>J17</sub>
ZX1100C2-C4 Ninja ZX-11	91-93	610-344R <sub>J</sub>	610-344SR <sub>J17</sub>
ZX1100D1-D9 Ninja ZX-11	93-01	610-344R <sub>J</sub>	610-344SR <sub>J17</sub>
ZX1100E1/E2/E3 GPz1100	95-97	610-352R <sub>J</sub> (LH) 610-435R <sub>J</sub> (RH)	_____
ZX1100F1 GPz1100 ABS	1996	610-352R <sub>J</sub> (LH) 610-435R <sub>J</sub> (RH)	_____
ZR1200A1-A5 ZRX1200	01-05	610-349R <sub>J</sub>	610-349SR <sub>J17</sub>

## Kawasaki

Model	Year	Hi-Perf. Front R <sub>JL</sub>	Super Racing Front SR <sub>JL17</sub>
ZX1200A1/A2/ Ninja ZX-12R	00-01	610-349R <sub>J</sub>	610-349SR <sub>J17</sub>
ZX1200B1/B2 Ninja ZX-12R	02-03	610-349R <sub>J</sub>	610-349SR <sub>J17</sub>
ZX1200B3-B6F ZX-12R	04-06	610-354R <sub>J</sub>	610-354SR <sub>J17</sub>
ZX1200C1-C5 ZZR1200	02-05	610-344R <sub>J</sub>	610-344SR <sub>J17</sub>
ZX1400A6F Ninja ZX-14	2006	610-354R <sub>J</sub>	610-354SR <sub>J17</sub>

## Suzuki

GSF600SY/SK1-SK3 Bandit	00-03	610-352R <sub>J</sub> (LH) 610-435R <sub>J</sub> (RH)	_____
GSX600F Katana	88-97	_____	_____
GSX600FW-FK6 Katana	98-06	610-352R <sub>J</sub> (LH) 610-435R <sub>J</sub> (RH)	_____
GSX-R600WN/WP	92-93	610-344R <sub>J</sub>	610-344SR <sub>J17</sub>
GSX-R600V-K3	97-03	610-344R <sub>J</sub>	610-344SR <sub>J17</sub>
GSX-R600K4-L0	04-10	610-355R <sub>J</sub>	_____
DL650K4/K5/K6	04-06	610-352R <sub>J</sub> (LH) 610-435R <sub>J</sub> (RH)	_____
SV650X/Y/K1-L0	99-10	610-352R <sub>J</sub> (LH) 610-435R <sub>J</sub> (RH)	_____
SV650S X-L0	99-10	610-352R <sub>J</sub> (LH) 610-435R <sub>J</sub> (RH)	_____
GSX750FW-FK6 Katana	98-06	610-352R <sub>J</sub> (LH) 610-435R <sub>J</sub> (RH)	_____
GSX-R750T/V/W/X	96-99	610-349R <sub>J</sub>	610-349SR <sub>J17</sub>
GSX-R750Y/K1/K2/K3	00-03	610-344R <sub>J</sub>	610-344SR <sub>J17</sub>
GSX-R750K4/K5/K6/K7	04-07	610-355R <sub>J</sub>	_____
DL1000K2-K9 V-Storm	04-09	610-352R <sub>J</sub> (LH) 610-435R <sub>J</sub> (RH)	_____
GSX-R1000K1/K2	01-02	610-349R <sub>J</sub>	610-349SR <sub>J17</sub>
GSX-R1000K3	2003	610-354R <sub>J</sub>	610-354SR <sub>J17</sub>
GSX-R1000K4-L1	04-11	610-355R <sub>J</sub>	_____
SV1000K3/K4/K5/K6	03-06	610-344R <sub>J</sub>	610-344SR <sub>J17</sub>
SV1000SK3-K7	03-07	610-344R <sub>J</sub>	610-344SR <sub>J17</sub>
TL1000RW-RK3	98-03	610-349R <sub>J</sub>	610-349SR <sub>J17</sub>
TL1000SV/SW/SX/SY/SK1	97-01	610-344R <sub>J</sub>	610-344SR <sub>J17</sub>
GSX-R1100WP-WW	93-98	610-349R <sub>J</sub>	610-349SR <sub>J17</sub>
GSF1200SK1-SK5 Bandit	01-05	610-349R <sub>J</sub>	610-349SR <sub>J17</sub>
GSF1200SK6 Bandit	2006	610-344R <sub>J</sub>	610-344SR <sub>J17</sub>
GSX1300RX-RK6 Hayabusa	99-06	610-349R <sub>J</sub>	610-349SR <sub>J17</sub>

## Yamaha

YZF600 K/KC-B/BC	98-12	610-248R <sub>J</sub>	610-248SR <sub>J17</sub>
YZF-R6L/LC-W/WC	99-08	610-248R <sub>J</sub>	610-248SR <sub>J17</sub>
YZF-R6SN/SNC Champion	2001	610-248R <sub>J</sub>	610-248SR <sub>J17</sub>
FZS1000N/NC/P/PC/R/RC FZ1	01-03	610-248R <sub>J</sub>	610-248SR <sub>J17</sub>
FZS1000S/SC/T/TC/VVC FZ1	04-06	610-248R <sub>J</sub>	610-248SR <sub>J17</sub>
FZS1000SPR/SPRC	2003	610-248R <sub>J</sub>	610-248SR <sub>J17</sub>
YZF1000R/J/R/JC	1997	610-248R <sub>J</sub>	610-248SR <sub>J17</sub>
YZF-R1L/LC-R/RC	98-03	610-248R <sub>J</sub>	610-248SR <sub>J17</sub>
YZF-R1S/SC-V/VVC	04-06	_____	_____
YZF-R1SN/SNC Champion	2001	610-248R <sub>J</sub>	610-248SR <sub>J17</sub>
FJR1300R/RC/S/SC/T/TC	03-05	610-248R <sub>J</sub>	610-248SR <sub>J17</sub>
FJR1300AS/ASC/AT/ATC	04-05	610-248R <sub>J</sub>	610-248SR <sub>J17</sub>

## High Performance Brake Calipers

Brembo 4 Piston Caliper w/2 Pin	610-262R <sub>J</sub>	_____
Brembo 4 Piston Caliper w/1 Pin	610-945R <sub>J</sub>	610-945SR <sub>J17</sub>
Brembo 4 Piston Caliper for Racing (P4.32/36A 20.6720)	610-969R <sub>J</sub>	610-969SR <sub>J17</sub>
Brembo 4 Piston Monoblock Caliper (P4.32/36 X1.017)	_____	610-969/2SR <sub>J17</sub>
Brembo 4 Piston Left 20.7850.11	02-06	610-986SR <sub>J17</sub>
Brembo 4 Piston Right 20.7850.21	02-06	610-986SR <sub>J17</sub>
Nissin 6 Piston Caliper	610-437R <sub>J</sub>	_____



331-001

## Sunstar Disc Brake Rotors for Harley-Davidson®

Stainless steel, high performance disc brake rotors. *Made in Japan* from the finest stainless steel with computer punched holes for heat and moisture dissipation. Light in weight, these "rust less" rotors are compatible with all disc pads, included sintered metal. The popularity of these rotors continue to increase due to the quality and superior performance. Sold each. Available for the following applications:

### Order No. 331-001

Front Single for FL, FLH (73-80), FX, FXE, XL (1973 only)

Rear for FL, FLH, FX, FXE, FXEF and FXS (73-80)

Replaces OEM 41813-79, 41806-72B, and 41813-92. (Diameter 10")

### Order No. 331-002

Front Dual Disc for FXE, FXEF, FXS (includes 77)

FXRS, FXRT, XLH, XLX, XLS.(78-83)

Replaces OEM 44137-79. (Diameter 10")

### Order No. 331-003

Front Single Disc for FX, FXE, XL(74-77)

Replaces OEM 41807-74. (Diameter 11-1/2")

### Order No. 331-004

Rear for FXE, FXEF, FXSB, FXWG, FXST, FXRS, FXRT, XL (81-85)

XLH, XLX, XLS, XR1000 (79-87)

Replaces OEM 41797-79. (Diameter 11-1/2")

### Order No. 331-005

Front Single Disc for FXE, FXEF, FXSB, FXWG, FXRS,

XLH, XLS, XLX, XR1000 (84-87)

Front Dual Disc for FXRT, FXRP (84-87), FLTC, FLHTC.

Replaces OEM 44136-92. (Diameter 11-1/2")

### Order No. 331-015

For (92-93) models, counterbored.

Replaces OEM 41791-92.



850-050

## Nissin 6 Piston Brake Calipers

Nissin 6-Piston brake calipers feature high performance stopping power along with great braking control. These calipers fit 280mm - 320mm diameter disc rotors. Sold each. *Made in Japan*. Available in the following bolt hole centers:

### 90mm Mounting Hole Center Brake Calipers

Description	Order No.
Brake Caliper Right Side 90mm	850-050
Brake Caliper Left Side 90mm	850-051
Fits Kawasaki ZX-6R (98-99), ZX-7R (97-01), ZX9R (97-99)	
Fits Suzuki GSX-R600 (98-99), GSX-R750 (88-99), RF900RR (94-97)	
Fits Suzuki TL1000R (98-01), TL1000S (97-01)	
Fits Suzuki GSF1200 Bandit (97-00) and GSX1300R Hayabusa (99-01)	

### 40mm Mounting Hole Center Brake Calipers

Description	Order No.
Brake Caliper Right Side 40mm	850-055
Brake Caliper Left Side 40mm	850-056
40mm compact type fits models with Brembo calipers - Ducati.	



## Sunstar ATV Disc Brake Rotors

Sold each. *Made in Japan*. Available for the following Suzuki ATV's:

### Suzuki

Model	Year	Front	Rear
LT250R Quadracer	87-92	331-006	331-007
LT500R Quadracer	87-90	331-008	331-009



# NGK Resistor Covers

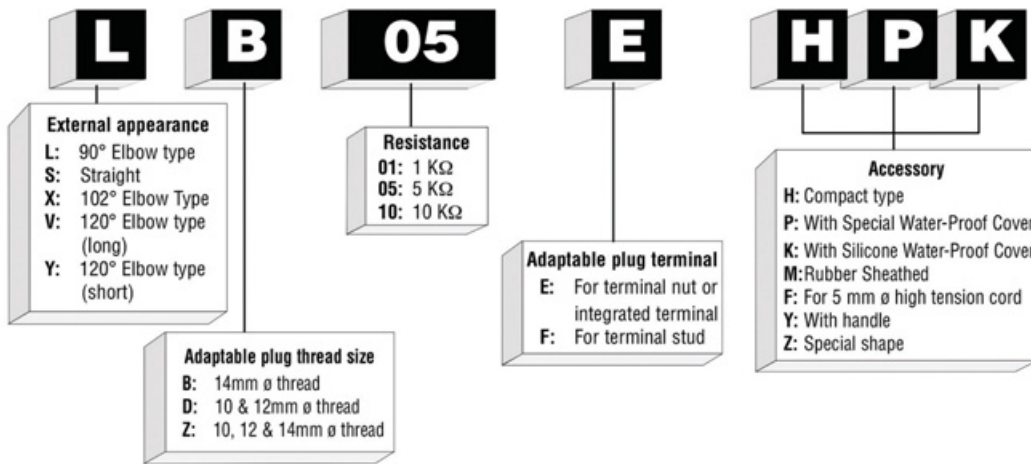











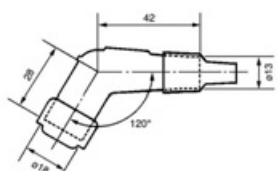

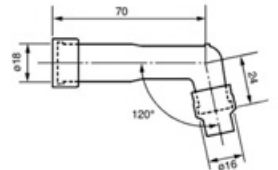

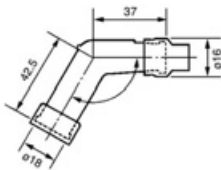
**NGK Resistor Covers** are to be used with the resistor type spark plugs. The covers are used to suppress the effect gained against radio frequency interference. Applications: motorcycles, snowmobiles, and general purpose engines.

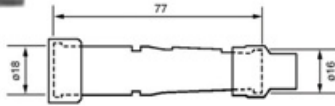
## Configuration (applicable plug thread diameter, body material) Unit: mm

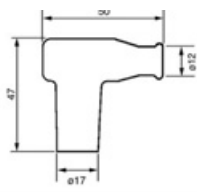
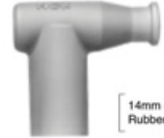
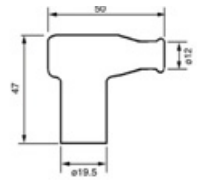
Image	NGK Part Number	Order Number
<p>LE, LB type: 14mm ø thread LD type: 10 &amp; 12mm ø thread Phenolic Resin</p> <p>&lt; Excluding LB EZ type &gt;</p>	LB01E	207-045
<p>14mm ø thread Phenolic Resin</p> <p>&lt; LB EZ &gt;</p>	LB05E	207-046
	LB01EP	207-048
	LB05EP	207-005
	LB05F	207-050
	LB05FP	207-006
	LB05EZ	207-051
	LB05EZA	207-052
<p>LB type: 14mm ø thread</p>	LB10E	207-055
	LB10EH	207-056
<p>10 &amp; 12mm ø thread Phenolic Resin</p>	LD05F	207-060
	LD05FP	207-061
<p>10mm ø CM-6 only Phenolic Resin</p>	LC05EFK	207-058

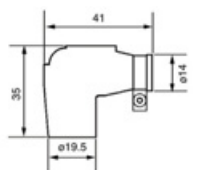

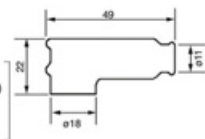
## Configuration (applicable plug thread diameter, body material) Unit: mm

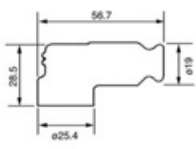
		NGK Part Number	Order Number
 <p>YB type: 14mm ø thread</p>		<b>YB05F</b> <b>YB05FP</b>	<b>207-080</b> <b>207-030</b>
 <p>XB type: 14mm ø thread XD type: 10 &amp; 12mm ø thread</p>		<b>XB05F</b> <b>XB05FP</b> <b>XD05F</b> <b>XD05FP</b>	<b>207-073</b> <b>207-074</b> <b>207-077</b> <b>207-025</b>
 <p>VB type: 14mm ø thread VD type: 10 &amp; 12mm ø thread Phenolic Resin</p>		<b>VB05E</b> <b>VB05F</b> <b>VB05FP</b> <b>VD05F</b> <b>VD05FP</b>	<b>207-065</b> <b>207-066</b> <b>207-067</b> <b>207-070</b> <b>207-020</b>
 <p>SB type: 14mm ø thread SD type: 10 &amp; 12mm ø thread</p>		<b>SB05E</b> <b>SB05F</b> <b>SB05FP</b> <b>SD05F</b> <b>SD05FP</b>	<b>207-039</b> <b>207-040</b> <b>207-041</b> <b>207-042</b> <b>207-015</b>
 <p>14mm ø thread Rubber sheathed (Silicon)</p>		<b>TB05EM (Red)</b>	<b>207-034</b>
 <p>14mm ø thread Rubber sheathed</p>		<b>TB05EMA (Black)</b> <b>TB05EMA (Green)</b> <b>TB05EMD (Black)</b>	<b>207-035</b> <b>207-036</b> <b>207-037</b>
 <p>14mm ø thread Rubber sheathed (Silicon)</p>		<b>LBER (Blue)</b>	<b>207-008</b>
 <p>14mm ø thread Rubber sheathed (Silicon) For racing spark plug R6120- only</p>		<b>TRS1225</b>	<b>207-085</b>
 <p>14mm ø thread Rubber sheathed (Silicon) For racing spark plug R5300A- only</p>		<b>TRS1408F</b>	<b>207-086</b>

# NGK Spark Plugs



## NGK Spark Plugs

Utilizing a wide variety of materials, from standard copper-core type to Iridium, NGK is the world's leader in spark plug engineering and technology. NGK Spark Plugs are original equipment on virtually every automotive, ATV, motorcycle, marine, scooter and small engine applications.

## Standard & Resistor Spark Plugs

The workhorse, at the heart of smooth-running engines worldwide. Available in standard or resistor.

- OEM quality
- Triple-Gasket Sealing Process
- Consistent Performance
- Plug of choice in millions of Motorcycles, ATV's and Scooters

NGK No.	Thread Size	Reach	Hex	Qt	Order No.
B4	14mm	3/8"	13/16"	Box/10	<a href="#">206-010</a>
B5HS	14mm	1/2"	13/16"	Box/10	<a href="#">206-015</a>
B6ES	14mm	3/4"	13/16"	Box/4	<a href="#">206-017</a>
B6HS	14mm	1/2"	13/16"	Box/4	<a href="#">206-019</a>
B6L	14mm	7/16"	13/16"	Box/10	<a href="#">206-020</a>
B6S	14mm	3/8"	13/16"	Box/10	<a href="#">206-021</a>
B7ES	14mm	3/4"	13/16"	Box/4	<a href="#">206-023</a>
B7HS	14mm	1/2"	13/16"	Box/10	<a href="#">206-025</a>
B8ES	14mm	3/4"	13/16"	Box/10	<a href="#">206-032</a>
B8HS	14mm	1/2"	13/16"	Box/10	<a href="#">206-035</a>
B8S	14mm	3/8"	13/16"	Box/10	<a href="#">206-037</a>
B9ES	14mm	3/4"	13/16"	Box/10	<a href="#">206-042</a>
B9HS	14mm	1/2"	13/16"	Box/10	<a href="#">206-045</a>
B10ES	14mm	3/4"	13/16"	Box/4	<a href="#">206-048</a>
BM6A	14mm	3/8"	3/4"	Box/10	<a href="#">206-170</a>
BMR6A	14mm	3/8"	3/4"	Box/10	<a href="#">206-171</a>
BP4HS	14mm	1/2"	13/16"	Box/10	<a href="#">206-059</a>
BP5EA-L	14mm	3/4"	13/16"	Box/4	<a href="#">206-174</a>
BP5ES	14mm	3/4"	13/16"	Box/4	<a href="#">206-175</a>
BP5ES-11	14mm	3/4"	13/16"	Box/4	<a href="#">206-050</a>
BP5HS	14mm	1/2"	13/16"	Box/10	<a href="#">206-052</a>
BP6ES	14mm	3/4"	13/16"	Box/4	<a href="#">206-053</a>
BP6HS	14mm	1/2"	13/16"	Box/4	<a href="#">206-054</a>
BP7ES	14mm	3/4"	13/16"	Box/4	<a href="#">206-055</a>
BP7HS	14mm	1/2"	13/16"	Box/4	<a href="#">206-056</a>
BP8ES	14mm	3/4"	13/16"	Box/10	<a href="#">206-058</a>
BP8HS	14mm	1/2"	13/16"	Box/10	<a href="#">206-057</a>
BP9ES	14mm	3/4"	13/16"	Box/10	<a href="#">206-520</a>
BPR4HS	14mm	1/2"	13/16"	Box/10	<a href="#">206-198</a>
BPR5ES-11	14mm	3/4"	13/16"	Box/4	<a href="#">206-060</a>
BPR5HS	14mm	1/2"	13/16"	Box/10	<a href="#">206-550</a>
BPR6ES	14mm	3/4"	13/16"	Box/4	<a href="#">206-061</a>
BPR6ES-11	14mm	3/4"	13/16"	Box/4	<a href="#">206-560</a>
BPR6HS	14mm	1/2"	13/16"	Box/10	<a href="#">206-062</a>
BPR6HSA	14mm	1/2"	13/16"	Box/10	<a href="#">206-199</a>
BPR7ES	14mm	3/4"	13/16"	Box/10	<a href="#">206-063</a>
BPR7ES-11	14mm	3/4"	13/16"	Box/10	<a href="#">206-064</a>
BPR7HS	14mm	1/2"	13/16"	Box/10	<a href="#">206-065</a>
BPR8ES	14mm	3/4"	13/16"	Box/10	<a href="#">206-068</a>

NGK No.	Thread Size	Reach	Hex	Qt	Order No.
BPR8HS	14mm	1/2"	13/16"	Box/10	<a href="#">206-066</a>
BR6EB-L-11	14mm	3/4"	13/16"	Box/4	<a href="#">206-576</a>
BR6HS	14mm	1/2"	13/16"	Box/10	<a href="#">206-180</a>
BR6HSA	14mm	1/2"	13/16"	Box/10	<a href="#">206-186</a>
BR7ES	14mm	3/4"	13/16"	Box/10	<a href="#">206-067</a>
BR7HS	14mm	1/2"	13/16"	Box/10	<a href="#">206-181</a>
BR8ES	14mm	3/4"	13/16"	Box/10	<a href="#">206-072</a>
BR8ES solid	14mm	3/4"	13/16"	Box/10	<a href="#">206-300</a>
BR8HS	14mm	1/2"	13/16"	Box/10	<a href="#">206-195</a>
BR8HSA	14mm	1/2"	13/16"	Box/10	<a href="#">206-188</a>
BR9ECS	14mm	3/4"	13/16"	Box/4	<a href="#">206-303</a>
BR9ES	14mm	3/4"	13/16"	Box/10	<a href="#">206-074</a>
BR9ES solid	14mm	3/4"	13/16"	Box/10	<a href="#">206-301</a>
BR9HS	14mm	1/2"	13/16"	Box/10	<a href="#">206-182</a>
BUHX	14mm	1/2"	13/16"	Box/10	<a href="#">206-594</a>
BUR6EB-11	14mm	3/4"	13/16"	Box/10	<a href="#">206-079</a>
C6HA	10mm	1/2"	5/8"	Box/10	<a href="#">206-191</a>
C6HSA	10mm	1/2"	5/8"	Box/10	<a href="#">206-080</a>
C7E	10mm	3/4"	5/8"	Box/10	<a href="#">206-250</a>
C7HSA	10mm	1/2"	5/8"	Box/10	<a href="#">206-081</a>
C8E	10mm	3/4"	5/8"	Box/10	<a href="#">206-193</a>
C8EH-9	10mm	3/4"	5/8"	Box/10	<a href="#">206-204</a>
C8HSA	10mm	1/2"	5/8"	Box/10	<a href="#">206-082</a>
C9E	10mm	3/4"	5/8"	Box/10	<a href="#">206-194</a>
CR10EK	10mm	3/4"	5/8"	Box/10	<a href="#">206-217</a>
CR5HSA	10mm	1/2"	5/8"	Box/10	<a href="#">206-083</a>
CR6HS	10mm	1/2"	5/8"	Box/10	<a href="#">206-084</a>
CR6HSA	10mm	1/2"	5/8"	Box/10	<a href="#">206-085</a>
CR7HS	10mm	1/2"	5/8"	Box/10	<a href="#">206-086</a>
CR7E	10mm	3/4"	5/8"	Box/10	<a href="#">206-210</a>
CR7HSA	10mm	1/2"	5/8"	Box/10	<a href="#">206-200</a>
CR8E	10mm	3/4"	5/8"	Box/10	<a href="#">206-196</a>
CR8EH9	10mm	3/4"	5/8"	Box/10	<a href="#">206-205</a>
CR8EK	10mm	3/4"	5/8"	Box/10	<a href="#">206-215</a>
CR9E	10mm	3/4"	5/8"	Box/10	<a href="#">206-197</a>
CR9EH9	10mm	3/4"	5/8"	Box/10	<a href="#">206-088</a>
CR9EK	10mm	3/4"	5/8"	Box/10	<a href="#">206-216</a>
D6EA	12mm	3/4"	18mm	Box/10	<a href="#">206-089</a>
D7EA	12mm	3/4"	18mm	Box/10	<a href="#">206-090</a>
D8EA	12mm	3/4"	18mm	Box/10	<a href="#">206-091</a>
D8HA	12mm	1/2"	18mm	Box/10	<a href="#">206-093</a>
D9EA	12mm	3/4"	18mm	Box/10	<a href="#">206-092</a>
DCPR7E	12mm	3/4"	5/8"	Box/10	<a href="#">206-322</a>
DP7EA-9	12mm	3/4"	18mm	Box/10	<a href="#">206-099</a>
DP8EA-9	12mm	3/4"	18mm	Box/10	<a href="#">206-100</a>
DP9EA-9	12mm	3/4"	18mm	Box/10	<a href="#">206-101</a>
DPR7EA-9	12mm	3/4"	18mm	Box/10	<a href="#">206-103</a>
DPR8EA-9	12mm	3/4"	18mm	Box/10	<a href="#">206-105</a>
DPR8Z	12mm	3/4"	18mm	Box/10	<a href="#">206-273</a>
DPR9EA-9	12mm	3/4"	18mm	Box/10	<a href="#">206-106</a>
DPR9Z	12mm	3/4"	18mm	Box/10	<a href="#">206-190</a>



## Standard & Resistor Spark Plugs

NGK No.	Thread Size	Reach	Hex	Qt	Order No.
DR7EA	12mm	3/4"	18mm	Box/10	<a href="#">206-320</a>
DR7ES	12mm	3/4"	18mm	Box/10	<a href="#">206-108</a>
DR8EA	12mm	3/4"	18mm	Box/10	<a href="#">206-119</a>
DR8ES	12mm	3/4"	18mm	Box/10	<a href="#">206-109</a>
DR8ES-L	12mm	3/4"	18mm	Box/10	<a href="#">206-110</a>
DR8HS	12mm	1/2"	18mm	Box/10	<a href="#">206-112</a>
DR9EA	12mm	3/4"	18mm	Box/10	<a href="#">206-120</a>
J9A	12mm	3/4"	18mm	Box/10	<a href="#">206-150</a>
J10A	12mm	3/4"	18mm	Box/10	<a href="#">206-160</a>
JR8C	12mm	3/4"	18mm	Box/10	<a href="#">206-146</a>
JR9B	12mm	3/4"	18mm	Box/10	<a href="#">206-157</a>
JR9C	12mm	3/4"	18mm	Box/10	<a href="#">206-156</a>
PJR7A	10mm	3/4"	5/8"	Box/10	<a href="#">206-235</a>

## Iridium IX Spark Plugs

Iridium IX Spark Plugs are the most technologically advanced high performance plugs available. Ultra-small diameter Iridium center electrode reduces voltage requirements and extends ignition system life. New metal shell plating has excellent anti-corrosion qualities.

NGK No.	Thread Size	Reach	Hex	Qt	Order No.
BPR5EIX-11	14mm	3/4"	13/16"	Box/4	<a href="#">206-325</a>
BR10EIX	14mm	3/4"	13/16"	Box/4	<a href="#">206-341</a>
BR10HIX	14mm	1/2"	13/16"	Box/4	<a href="#">206-335</a>
BR7EIX	14mm	3/4"	13/16"	Box/4	<a href="#">206-338</a>
BR7HIX	14mm	1/2"	13/16"	Box/4	<a href="#">206-332</a>
BR8EIX	14mm	3/4"	13/16"	Box/4	<a href="#">206-339</a>
BR8HIX	14mm	1/2"	13/16"	Box/4	<a href="#">206-333</a>
BR9EIX	14mm	3/4"	13/16"	Box/4	<a href="#">206-340</a>
C7HVX	10mm	1/2"	5/8"	Box/4	<a href="#">206-252</a>
CR7HIX	10mm	1/2"	5/8"	Box/4	<a href="#">206-355</a>
CR8EHIX-9	10mm	3/4"	5/8"	Box/4	<a href="#">206-345</a>
CR8EIX	10mm	3/4"	5/8"	Box/4	<a href="#">206-349</a>
CR9EHIX-9	10mm	3/4"	5/8"	Box/4	<a href="#">206-346</a>
CR9EIX	10mm	3/4"	5/8"	Box/4	<a href="#">206-350</a>
DCPR6EIX	12mm	3/4"	5/8"	Box/4	<a href="#">206-388</a>
DCPR7EIX	12mm	3/4"	18mm	Box/4	<a href="#">206-323</a>
DCPR9EIX	12mm	3/4"	5/8"	Box/4	<a href="#">206-368</a>
DPR8EIX-9	12mm	3/4"	18mm	Box/4	<a href="#">206-270</a>
DPR9EIX-9	12mm	3/4"	18mm	Box/4	<a href="#">206-271</a>

## Lazer Iridium IX Spark Plugs

NGK No.	Thread Size	Reach	Hex	Qt	Order No.
DR8EIX	12mm	3/4"	18mm	Box/4	<a href="#">206-360</a>
IFR8H11	10mm	3/4"	5/8"	Box/4	<a href="#">206-380</a>
IFR9H11	10mm	3/4"	5/8"	Box/4	<a href="#">206-381</a>
IMR8C-9H	10mm	3/4"	5/8"	Box/4	<a href="#">206-385</a>

## G-Type Racing Spark Plugs

Nickel alloy fine wire electrode.

NGK No.	Thread Size	Reach	Hex	Qt	Order No.
B10EG	14mm	3/4"	13/16"	Box/4	<a href="#">206-046</a>
B8EG	14mm	3/4"	13/16"	Box/4	<a href="#">206-030</a>
B9EG	14mm	3/4"	13/16"	Box/4	<a href="#">206-040</a>
BR10EG	14mm	3/4"	13/16"	Box/4	<a href="#">206-076</a>
BR8EG	14mm	3/4"	13/16"	Box/4	<a href="#">206-070</a>
BR9EG	14mm	3/4"	13/16"	Box/4	<a href="#">206-073</a>
R4118S-8	14mm	3/4"	13/16"	Box/4	<a href="#">206-228</a>
R4118S-9	14mm	3/4"	13/16"	Box/4	<a href="#">206-233</a>
R5184-10	14mm	3/4"	13/16"	Box/4	<a href="#">206-232</a>
R5672A-9	14mm	3/4"	5/8"	Box/4	<a href="#">206-231</a>
R6254E-105	14mm	3/4"	13/16"	Box/4	<a href="#">206-225</a>
R6254K-105	14mm	3/4"	13/16"	Box/4	<a href="#">206-226</a>
R7376-10	14mm	3/4"	13/16"	Box/4	<a href="#">206-227</a>

## G-Type Racing Spark Plugs

Nickel alloy fine wire electrode.

NGK No.	Thread Size	Reach	Hex	Qt	Order No.
B105EGV	14mm	3/4"	13/16"	Box/4	<a href="#">206-316</a>
B10EGV	14mm	3/4"	13/16"	Box/4	<a href="#">206-047</a>
B8EGV	14mm	3/4"	13/16"	Box/4	<a href="#">206-031</a>
B95EGV	14mm	3/4"	13/16"	Box/4	<a href="#">206-315</a>
B9EGV	14mm	3/4"	13/16"	Box/4	<a href="#">206-041</a>

## VX-Type Platinum Spark Plugs

Fine wire electrode, non resistor

NGK No.	Thread Size	Reach	Hex	Qt	Order No.
C8EVX	10mm	3/4"	5/8"	Box/4	<a href="#">206-262</a>
D7EVX	12mm	3/4"	18mm	Box/4	<a href="#">206-265</a>
D8EVX	12mm	3/4"	18mm	Box/4	<a href="#">206-266</a>



## NGK Spark Plug Indexing Washer Kit

Kits include 3 different thicknesses. (total 15pcs.)

10mm	<a href="#">207-200</a>
12mm	<a href="#">207-201</a>
14mm	<a href="#">207-202</a>

NGK Master Spark Plug Application catalog available.

Order No. [950-990](#)

# Ignition Products



207-102



207-101



618-650

## NGK Premium Quality Racing Cables

Available in straight or 90° resistor covers. Sold each.

- Water Resistant, rugged silicone insulation
- High Output stranded copper wire
- 5k ohm ceramic resistor cover for excellent defense against RFI (radio frequency interference)

### 90° Resistor Covers

Cap Type	Wire Length	Order No.
Removable	50cm (20")	207-101
Removable	100cm (39")	207-104
Solid	50cm (20")	207-103
Solid	100cm (39")	207-105

### Straight Resistor Covers

Removable	50cm (20")	207-100
Solid	50cm (20")	207-102



## Nology Ignition Wire

Sold 1 foot length.

Description	Nology No.	Order No.
7mm Red Silicone Secondary Wire	S.I.W.-R	618-650
7mm Black Silicone Secondary Wire	S.I.W.-B	618-651



618-633

## NGK Inline Wire Connector

Made of high-impact plastic, this handy unit will solve all wire connection problems. Simply insert lead from ignition coil in one end, the new wire lead in other end and screw the two pieces for a watertight connection.

Order No. 207-120

## Nology Connector Accessories

1K Ohm 90° Coil Connector (big red body only)	CS-1	618-631
1K Ohm in-line Secondary Wire Splice	CS-3	618-633





## Nology Hot Wires

Hot Wires are engineered with a unique built-in capacitor that allows energy from the ignition coil to accumulate (stored) until the voltage can be released as an ultra-short, ultra-hot spark. Combustion is faster and more complete, resulting in increased horsepower and a more complete burn. Hot Wires are compatible with all aftermarket or stock ignition systems. Electronic ignitions are preferred but satisfactory results are achieved with point ignition when the points and condenser are in perfect working order. Each Hot Wire includes a 23" or 30" black silicone Hot Wire with grounding strap, 90 degree or 180 degree (straight) spark plug cap, in-line wire connector and heat shrink tubing. Sold each. **Note:** Requires non-resistor spark plugs.

### 23" Length Hot Wires, 7mm

Description	Nology No.	Order No.
90 Degree Plug Boot	HW-MC-90-23B	<b>618-600</b>
90 Degree Plug Boot (use with Karts)	HW-GK-90-23	<b>618-610</b>
180 Degree Plug Boot	HW-MC-180-23B	<b>618-601</b>

### 30" Length Hot Wires, 7mm

Description	Nology No.	Order No.
90 Degree Plug Boot	HW-MC-90-30B	<b>618-602</b>
180 Degree Plug Boot	HW-MC-180-30B	<b>618-603</b>

## Nology Hot Wires - Model Specific Applications

Available in kits for applications listed.

### Ducati

Model	Year	Color	Nology No.	Order No.
851 Strada	89-02	Red	012 042 401	<b>618-439</b>
916	93-98	Red	012 042 401	<b>618-439</b>
996	98-01	Red	012 042 401	<b>618-439</b>

### Honda

VF750C V45 Magna	82-83	Black	012 064 302	<b>618-449</b>
VF750F V45 Interceptor	83-84	Black	012 064 302	<b>618-449</b>
VF750S V45 Sabre	82-83	Black	012 064 302	<b>618-449</b>
VFR1000F Interceptor	1984	Black	012 064 302	<b>618-449</b>
VFR1000R	85-86	Black	012 064 302	<b>618-449</b>
VF1100C V65 Magna	83-86	Black	012 064 302	<b>618-449</b>
VF1100S V65 Sabre	82-83	Black	012 064 302	<b>618-449</b>

### Suzuki

SV650X/Y/K1/K2	99-02	Red	012 112 021	<b>618-462</b>
SV650SX/SY/SK1/SK2	99-02	Red	012 112 021	<b>618-462</b>

### Yamaha

WR400F/YZ400F(S.O.T.)	1999	Red	012 131 001	<b>618-469</b>
FZ750	85-88	Black	012 134 002	<b>618-471</b>
FZR750RT/RU	87-88	Black	012 134 002	<b>618-471</b>



## Nology Pro Fire Compact Ignition Coils

Pro Fire ignition coils utilize advanced technology to supply the energy needed for trouble-free high performance and high rpm operation. They are designed to have the quickest rise time along with substantial energy reserves. Spark voltage is in excess of 45,000 volts over the entire rpm range. Pro Fire coils come in single or dual high tension towers and are available in 0.3 ohm, 0.6 ohm, 1.5 ohm and 3.0 ohm. Coil connectors and boot are included. Sold each.

**Note:** To determine which Nology ignition coil to use, measure the primary winding resistance of your stock ignition coil. Round down to the nearest whole ohm.

0.5 ohm and 0.6 ohm primary resistance ignition coils are for C.D.I. type ignitions found on late model ATV, Dual Sport, MX. and Offroad.

**Note:** Do not use Nology Ignition Coils on point type ignitions or on the following models: Honda VFR, CB, CBX; Kawasaki ZX10, GPZ, KZ1000J, Z1-900; Suzuki GSXR (early oil cooled), GS; Yamaha FJ1100/1200 and VMX12 V-Max.

Description	Ohms	Nology No.	Order No.
Single Secondary outlet	3.0 primary	PFC-30-S	<b>618-510</b>
	0.6 primary (C.D.I.)	PFC-06-S	<b>618-512</b>
	0.3 primary (C.D.I.)	PFC-03-S	<b>618-514</b>
Dual Secondary outlet	3.0 primary	PFC-30-D	<b>618-511</b>
	0.6 primary (C.D.I.)	PFC-06-D	<b>618-513</b>
	0.3 primary (C.D.I.)	PFC-03-D	<b>618-515</b>



618-769

## Dyna Ignition Coil Kits for Yamaha

These high tech ignition coils for Yamaha models listed provide maximum performance, producing spark voltage in excess of 30,000 volts. Sold as a kit.

### Yamaha

Model	Year	Dyna No.	Order No.
YXR450 Rhino Side x Side	06-07	DCK7-2	<b>618-769</b>
YXR660 Rhino Side x Side	04-07	DCK7-2	<b>618-769</b>
XVS1100 V-Star 1100	05-08	DCK7-7	<b>618-770</b>

# Ignition Coils



## Dyna Mini Series Coils

Advanced magnetic core technology delivers high output in one of the smallest packages available. These coils are designed for use with the Dyna 2000 and 3000 series ignitions, factory installed electronics, or other aftermarket ignitions that employ dwell control.

Ohms	Qt	Use with Ignition	Output	Dyna No.	Order No.
3.0	2	Dyna 2000HD	Dual	DC1-2	<a href="#">618-980</a>
		Dyna 2000i/D2Ki	Dual	DC1-2	<a href="#">618-980</a>
		Dyna S HD	Dual	DC1-2	<a href="#">618-980</a>
		Stock/Dyna S	Dual	DC1-2	<a href="#">618-980</a>
3.0	1	Stock	Dual	DC1-3	<a href="#">618-981</a>
3.0	2	Dyna 2000HD	Single	DC3-2	<a href="#">618-982</a>
		Dyna 2000i/D2Ki	Single	DC3-2	<a href="#">618-982</a>
		Dyna S HD	Single	DC3-2	<a href="#">618-982</a>
		Stock/Dyna S	Single	DC3-2	<a href="#">618-982</a>
3.0	1	Stock	Single	DC3-3	<a href="#">618-983</a>

## Dyna Twin Fire Mini Coil

This mini coil will fit under the tank on most XL and FLH models as well as in the stock location on the side of the motor for FXR models or rear of the motor for Dyna and Softail models.

Ohms	Qt	Use with Ignition	Output	Dyna No.	Order No.
3.0	1	Dyna 2000HD	Twin Fire II	DC6-5	<a href="#">618-984</a>
		Dyna 2000i/D2Ki			



## Dynatek "Dyna" Ignition Wires

Dynatek "Dyna" wires are made from high grade, silicon jacketed, high tension cable. All wires are supplied with spark plug boot and loose coil terminals. Dyna wires are available in solid copper core and graphite suppressor. Use Dyna solid core wires where electrical interference is not an issue. Use Dyna suppressor wires for applications with electronic advance ignitions or other sensitive electronic equipment. Both wire types ensure maximum energy transfer.

**Note:** DW200, DW300, DW600, and DW800 wire sets include parts for 4-cylinder models. DW1100 and DW1200 include parts for 2-cylinder models. Sold in sets in different colors.

Description	Color	Dyna No.	Order No.
7mm Copper Core	Black	DW-200	<a href="#">618-781</a>
7mm Copper Core	Red	DW-300	<a href="#">618-782</a>
7mm Graphite Suppressor	Black	DW-600	<a href="#">618-784</a>
7mm Graphite Suppressor	Grey	DW-800	<a href="#">618-786</a>
7mm Graphite Suppressor	Black	DW-1100	<a href="#">618-787</a>
8mm Graphite Suppressor	Grey	DW-1200	<a href="#">618-788</a>

## Dyna Ignition Coils

Dyna Ignition coils are high tech, top quality coils designed for maximum performance. They produce spark voltages in excess of 30,000 volts and spark energies second to none. Dyna coils are available in a wide variety of resistances and output configurations to allow easy replacement of stock coils. Dyna coils work with factory electronic ignitions, points and aftermarket ignitions. Before selecting a coil, check the coil primary resistance requirements as specified by the manufacturer of the ignition being used. All Dyna coils are sold in pairs unless otherwise noted.

Ohms	Qt	Use with Ignition	Output	Dyna No.	Order No.
0.7	2	Dyna 4000	Dual	DC9-1	<a href="#">618-766</a>
1.5	2	Dyna "S" HD	Dual	DC2-1	<a href="#">618-751</a>
1.5	2	Dyna "S" BMW	Dual	DC2-1	<a href="#">618-751</a>
2.2	2	Dyna 2000/4	Dual	DC4-1	<a href="#">618-753</a>
2.2	2	Stock	Dual	DC4-1	<a href="#">618-753</a>
3.0	2	Dyna 2000 HD	Single	DC3-1	<a href="#">618-752</a>
		Dyna 2000i/D2KI	Single	DC3-1	<a href="#">618-752</a>
		Dyna "S" HD	Single	DC3-1	<a href="#">618-752</a>
3.0	2	Dyna 2000 HD	Dual	DC1-1	<a href="#">618-750</a>
		Dyna 2000i/D2KI	Dual	DC1-1	<a href="#">618-750</a>
		Dyna "S" HD	Dual	DC1-1	<a href="#">618-750</a>
		Stock/Dyna "S"	Dual	DC1-1	<a href="#">618-750</a>
3.0	1	Dyna 200HD	Dual	DC6-1	<a href="#">618-755</a>
		Dyna 200i/D2KI	Dual	DC6-1	<a href="#">618-755</a>
		Dyna "S" HD	Dual	DC6-1	<a href="#">618-755</a>
5.0	2	Dyna "S"	Single	DC10-1	<a href="#">618-763</a>
5.0	2	Dyna "S" HD	Dual	DC8-1	<a href="#">618-760</a>
		Stock (point model)	Dual	DC8-1	<a href="#">618-760</a>
5.0	1	Dyna "S" HD	Dual	DC7-1	<a href="#">618-759</a>
		Stock point model HD	Dual	DC7-1	<a href="#">618-759</a>



## Dyna Twin Fire Ignition Coils

The Dyna Twin Fire ignition coils are the newest standard for performance and packaging efficiency for single fire installations. Compact size fits easily under stock covers. Over 40,000 volts per output. Accepts 7 to 8.8mm wires.

Ohms	Qt	Use with Ignition	Output	Dyna No.	Order No.
3.0	1	Dyna 2000	dual, high location	DC6-2	<a href="#">618-756</a>
3.0	1	Dyna 2000	dual, low location	DC6-3	<a href="#">618-757</a>
3.0	1	Dyna 2000HD	single fire II	DC6-4	<a href="#">618-758</a>
		Dyna 2000i/D2Ki	single fire II	DC6-4	<a href="#">618-758</a>
0.7	1	Dyna 4000	four tower, twin fire coil	DC9-2	<a href="#">618-767</a>

## Ignition Coil for Kawasaki & Suzuki

Point type ignition coil for the Kawasaki and Suzuki models listed.

**Note:** Ignition Coils are not marked 1 & 4 or 2 & 3. Sold each.

Order No. **618-110**

### Ignition Coil Specifications

**Low Tension Wires:** 39cm (15") long with female spade connectors at coil and male bullet connectors on the other end.

**Spark Plug Wires (HT Leads):** 57.5cm (24") long with a 30cm (12") long protective sheath.

**Center to Center Mounting Distance:** 90mm between mounting screw holes.

### Kawasaki

Model	Year
KZ400A1/A2	77-78
KZ400B1/B2	78-79
KZ400C1	1978
KZ400/D/D3/D3	74-77
KZ400H1 LTD	1979
KZ400S/S2/S3 Special	75-77
KZ440A1	1980
KZ440B1	1980
KZ440D1	1980
KZ650B1/B2/B2A/B3	77-79
KZ650C1/C2/C3 Custom	77-79
KZ650D1/D2 SR	78-79
KZ650E1 LTD	1980
KZ650F1	1980
KZ750B1/B2/B3/B4 (2-cylinder)	76-79
KZ750G1 LTD (2-cylinder)	1980
KZ900A4/A5	76-77
KZ900B1 LTD	1976



### Kawasaki

Model	Year
Z1/A/B-900	73-75
KZ1000A1/A2	77-78
KZ1000B1/B2/B3 LTD	77-79
KZ1000C1/C1A/C2 Police	78-79

### Suzuki

GS550B/C/EC/N	77-79
GS550LN	1979
GS750B/C/EC/N/EN	77-79
GS750LN	1979
GS850GN	1979
GS1000C/EC/N/EN	78-79
GS1000LN	1979
GS1000SN	1979



## Ignition Coil Set for Kawasaki H2-750

These OEM style replica high tension coils fit Kawasaki's legendary H2-750 2-stroke triple, 1972-1975. Sold as a complete set of 3 coils, wires, & caps. Kawasaki OEM reference: 21121-064.

Order No. **618-112**



## Universal 12 Volt Ignition Coil

This Universal 12 volt Ignition Coil comes complete with mounting Bracket. 12 volts, 5.0 ohms.

Order No. **618-114**



## Dyna 3000 Digital Performance Ignition Module for Cruisers

The Dyna 3000 combines state of the art microprocessor technology. Direct mounting on factory locations so you can maximize engine performance by setting ignition timing to fit your specifications.

Features include:

- 10 advance curves for Honda, 8 Advance Curves for Kaw/Suz/Yam
- 9 Selectable Rev Limits for Honda (increased rev limits over stock)
- 8 Selectable Rev Limits for Kaw/Suz/Yam (increased rev limits over stock)
- STATUS LED:
  - A) Indicates power-up, (all models listed)
  - B) Indicates pick-ups (all models listed)
  - C) Indicates TPS (throttle position sensor) operation (applicable models only)
  - D) Indicates MAP sensor operation (applicable models only)
  - E) Retard Function (applicable models only)
- Easier Starting
- Plug and ride, 5 minute installation (on most models)
- Uses all Factory Sensors
- Mounts Directly to Factory Location
- Use OEM Ignition Coils or Dyna Ignition Coils
- Reverse Battery Protection

Available for the following models:

### Honda

Application	Year	Dyna No.	Order No.
VT750C Shadow	98-00	D3K1-3	<a href="#">618-677</a>
VT750CD Shadow Deluxe	98-01	D3K1-3	<a href="#">618-677</a>
VT750CD2 Shadow Deluxe	98-01	D3K1-3	<a href="#">618-677</a>
VT1100C2 Shadow 1100 A.C.E.	97-00	D3K1-2	<a href="#">618-676</a>
VT1100C3 Shadow Aero	98-00	D3K1-2	<a href="#">618-676</a>
VT1100D2 Shadow 1100 A.C.E.	1999	D3K1-2	<a href="#">618-676</a>
GL1500C Valkyrie	97-00	D3K1-1	<a href="#">618-675</a>
GL1500C Valkyrie	2003	D3K1-1	<a href="#">618-675</a>
GL1500CD Valkyrie	01-03	D3K1-1	<a href="#">618-675</a>
GL1500CF Valkyrie Interstate	99-01	D3K1-1	<a href="#">618-675</a>
GL1500CT Valkyrie Tourer	97-00	D3K1-1	<a href="#">618-675</a>

### Kawasaki

VN800C1/C2 Vulcan Drifter	99-00	D3K2-1	<a href="#">618-681</a>
VN800E1-E6F Vulcan Drifter	01-06	D3K2-1	<a href="#">618-681</a>
VN1500E2-E7 Vulcan Classic	99-04	D3K2-2	<a href="#">618-682</a>
VN1500G1/G1A/G2 Vulcan Nomad	99-00	D3K2-2	<a href="#">618-682</a>

### Suzuki

VS1400GL Intruder	90-95	D3K3-1	<a href="#">618-685</a>
VS1400GL Intruder	96-07	D3K3-2	<a href="#">618-686</a>
VL1500W Intruder 1500LC	1998	D3K3-3	<a href="#">618-687</a>
VL1500X-K4 Intruder 1500LC	99-04	D3K3-4	<a href="#">618-688</a>

## Yamaha

Application	Year	Dyna No.	Order No.
XVS650 V-Star	98-02	D3K7-1	<a href="#">618-691</a>
XVS1100 V-Star	99-03	D3K7-2	<a href="#">618-692</a>
XVS1100 V-Star (49 state only)	04-05	D3K7-2	<a href="#">618-692</a>
XVS1100 V-Star	05-08	D3K7-8	<a href="#">618-697</a>
XVZ1300A Royal Star Boulevard	96-01	D3K7-4	<a href="#">618-694</a>
XVZ1300T Royal Star Venture	99-08	D3K7-5	<a href="#">618-695</a>
VMX12 V-Max	90-07	D3K7-6	<a href="#">618-696</a>
XV1600 Road Star	99-03	D3K7-3	<a href="#">618-693</a>
XV1700 Road Star	04-07	D3K7-3	<a href="#">618-693</a>



## Boyer Bransden Electronic Ignition

Boyer Bransden ignitions are fully electronic "breakerless" kits and are compatible with positive or negative ground systems. Boyer ignitions are capable of reliable operation up to 10,000 RPM on most 4-stroke applications. "Reliable As Rock" reputation and virtually maintenance free when installed on a fully functional charging system. Available for the following applications:

Application	Mfg. No.	Order No.
BSA/Triumph Triple 3-Cyl.	JRC3577	<a href="#">618-902</a>
BSA/Triumph Twin 2-Cyl. (Unit Type Twin)	JRC3576	<a href="#">618-901</a>
BSA/Triumph Single (Unit Type Single)	JRC3578	<a href="#">618-903</a>
Norton Twin (Atlas, P11, N15, Commando)	JRC3575	<a href="#">618-900</a>
Yamaha XS650 Twin (70-78)	JRC35103	<a href="#">618-904</a>





## Dyna 2000 Digital Performance Ignition for Sportbikes

The Dyna 2000 Digital Performance Ignition represents a break through in motorcycle ignition flexibility. The Dyna 2000 system consists of a state-of-the-art microprocessor controlled ignition module along with an adjustable Dyna dual sensor crank trigger. For the first time you can actually set the ignition timing to what you want to maximize engine performance. A number of different advance modes and a broad range rev limiter let you tailor the ignition to your needs.

**Note:** Sudco part numbers with an asterisk\* come with compatible Dyna Ignition coils.

### Honda

Application	Year	Dyna No.	Order No.
CBR600F2 Hurricane	91-94	DDK1-7	<b>618-831</b>
CBR600F3 Hurricane	95-97	DDK1-8	<b>618-832</b>
CB750/900/1100 DOHC	79-83	DDK1-5	<b>618-860</b>
CB750/900/1100 DOHC (with coils*)	79-83	DDK1-5C	<b>618-861*</b>
CBR900RR	93-99	DDK1-9	<b>618-833</b>
CBR1100XX Blackbird	97-98	DDK1-10	<b>618-857</b>

### Kawasaki

KZ550D1 GPZ (with coils*)	1981	DDK2-3C	<b>618-869*</b>
ZX600G1/G2 Ninja ZX-6R	98-99	DDK2-11	<b>618-875</b>
ZX600J1/J2 Ninja ZX-6R	00-01	DDK2-11	<b>618-875</b>
KZ650B/C/E/F	77-80	DDK2-2	<b>618-867</b>
KZ650B/C/E/F (with coils*)	77-80	DDK2-2C	<b>618-856*</b>
KZ750/ZX750	80-84	DDK2-2	<b>618-867</b>
KZ750/ZX750 (with coils*)	80-84	DDK2-2C	<b>618-856*</b>
ZX750 Ninja ZX7/ZX-7R/ZX-7RR	91-97	DDK2-7	<b>618-837</b>
Z1-900/KZ900	73-76	DDK2-1	<b>618-865</b>
Z1-900/KZ900 (with coils*)	73-76	DDK2-1C	<b>618-866*</b>
ZX900A1/A2 Ninja 900R	84-85	DDK2-4	<b>618-834</b>
ZX900B Ninja ZX-9R	94-97	DDK2-7	<b>618-837</b>
ZX900C/E/F Ninja ZX-9R (with coils*)	98-03	DDK2-12C	<b>618-874*</b>
KZ1000/1100	77-85	DDK2-1	<b>618-865</b>
KZ1000/1100 (with coils*)	77-85	DDK2-1C	<b>618-866*</b>
KZ1100 GPz modified	81-84	DDK2-1	<b>618-865</b>
KZ1100 GPz modified (with coils*)	81-84	DDK2-1C	<b>618-866*</b>
ZX1000A1/A2 Ninja 1000R	86-87	DDK2-4	<b>618-834</b>
ZX1000B1/B2/B3 Ninja ZX-10	88-90	DDK2-4	<b>618-834</b>
ZX1100C/D Ninja ZX-11	90-01	DDK2-4	<b>618-834</b>

### Suzuki

GS550/750/850	77-81	DSK3-2	<b>618-870</b>
GSX600F/GSX750F Katana	88-95	DDK3-3	<b>618-840</b>
RF600RR/RS/RT	94-96	DDK3-4	<b>618-841</b>
RF900RR/RS/RZS/RT/RV	94-97	DDK3-4	<b>618-841</b>
GSX-R750G/H/J/K/L/M/N	86-92	DDK3-3	<b>618-840</b>
GSX-R750WP/WR/WS	93-95	DDK3-4	<b>618-841</b>

### Suzuki

Application	Year	Dyna No.	Order No.
GS1000/1100/1150	77-85	DSK3-2	<b>618-870</b>
GS1000/1100/1150 (with coils*)	77-85	DSK3-2C	<b>618-871*</b>
GSX1100F Katana	88-93	DDK3-3	<b>618-840</b>
GSX-R1100G/H/J/K/L/M/N	86-92	DDK3-3	<b>618-840</b>
GSX-R1100WP-WV	93-97	DDK3-4	<b>618-841</b>
GSF1200SV-SK5 Bandit	97-05	DDK3-3	<b>618-840</b>
GSF1200SAV Bandit	1997	DDK3-3	<b>618-840</b>

### Yamaha

FJ1100/1200	84-92	DDK7-1	<b>618-845</b>
-------------	-------	--------	----------------



## Dyna-S Electronic Ignition

The Dyna-S is a complete self-contained electronic ignition built with the latest state-of-the-art engineering. The Dyna S is completely housed behind the ignition cover and uses a magnetic rotor with the original spark advancer, so the factory advance curve is maintained. Tidy, no fuss installation. Recommended DYNA Ignition Coil is listed after Order No.

### Ducati

Application	Year	Dyna No.	Order No.	Dyna Ign. Coil
750 Twins	72-74	DS4-1	<b>618-727</b>	<b>618-763</b>

### Honda

CB350F/CB400F	72-77	DS1-1	<b>618-720</b>	<b>618-760</b>
CB500/550/750	69-78	DS1-2	<b>618-721</b>	<b>618-750</b>
GL1000	75-79	DS1-3	<b>618-722</b>	<b>618-750</b>

### Kawasaki

KZ550/650/750 (4-cyl.)	ALL	DS2-2	<b>618-724</b>	<b>618-750</b>
Z1-900/KZ900 (4-cyl.)	73-76	DS2-1	<b>618-723</b>	<b>618-750</b>
KZ1000/1100 (4-cyl.)	77-85	DS2-1	<b>618-723</b>	<b>618-750</b>

### Moto Guzzi

V35/V50/V65	ALL	DS5-1	<b>618-728</b>	<b>618-763</b>
-------------	-----	-------	----------------	----------------

### Suzuki

GS550/1100	77-81	DS3-2	<b>618-726</b>	<b>618-750</b>
GS1000/1100	82-83	DS3-2	<b>618-726</b>	<b>618-750</b>



## Dyna FS Digital Performance Ignition

The Dyna FS ignition is used by winning pro racers worldwide. Get the most out of your modifications by tuning the ignition. The Dyna FS lets you customize and adjust power delivery to fit your riding style. Dyna FS ignition is available in Programmable and Non-programmable. Sold each. Available for the following ATV's and motorcycles.

### Honda

Model	Year	Dyna P/N	Order No.
XR50R/XR80R	ALL	DFS1-12	<b>618-969</b>
CR125R	2000	DFS1-1	<b>618-908</b>
CR125R	2001	DFS1-6P	<b>618-963P</b>
CR250R	2000	DFS1-2	<b>618-909</b>
TRX400EX Fourtrax 400EX	99-00	DFS1-10P	<b>618-967P</b>
TRX400EX Sportrax 400EX	01-04	DFS1-10P	<b>618-967P</b>
TRX400EX Sportrax 400EX	05-08	DFS1-14P	_____
TRX450R	04-05	DFS1-13P	<b>618-970P</b>

### Kawasaki

KX125	2000	DFS2-1P	<b>618-910P</b>
KFS400A KFX400	03-04	DFS2-11P	_____
KVF650 Prairie 4x4	03-07	DFS2-13	<b>618-949</b>
KVF650 Brute Force 750 4x4	05-07	DFS2-15	_____
KFX700 V-Force	03-07	DFS2-14	<b>618-950</b>
KVF700 Prairie	04-06	DFS2-13	<b>618-949</b>
KVF750 Brute Force 750 4x4i	05-07	DFS2-15	_____

### Polaris

Predator 500	03-04	DFS9-1P	<b>618-943P</b>
Predator 500	2005	DFS9-2P	_____

### Suzuki

RM125	2002	DFS3-7P	<b>618-926P</b>
LT-Z400K QuadSport	03-04	DFS3-9P	<b>618-928P</b>
LT-Z400K QuadSport	05-08	DFS3-12P	_____
LT-V700F Twin Peaks	04-05	DFS3-11	_____

### Yamaha

YFM350R Raptor 350	04-12	DFS7-16	_____
YFM350X Warrior	97-01	DFS7-9P	<b>618-936P</b>
YFZ350 Banshee	87-94	DFS7-8P	<b>618-939P</b>
YFZ350 Banshee	95-96	DFS7-7P	<b>618-945P</b>
YFZ350 Banshee	97-06	DFS7-6P	<b>618-935P</b>
YFZ450	04-09	DFS7-12P	<b>618-942P</b>
YFM660R Raptor 660R	2001	DFS7-10P	<b>618-937P</b>
YFM660R Raptor 660R	02-05	DFS7-11P	<b>618-938P</b>
YXR660 Rhino	04-07	DFS7-13	<b>618-946</b>
YFM700R Raptor 700R <b>New</b>	06-12	DFS7-21P	<b>618-948P</b>
YXR700 Rhino	08-12	DFS7-26	<b>618-947</b>

### Programmable Ignition features:

(P listed after Dyna and Sudco part number)

- Programmable timing curves (4)
- Programmable rev limits
- Increased spark energy
- Improved throttle response
- Easier starting
- Tach Output
- Launch limiter
- Shift kill interrupt
- Data logging
- External curve selector switch
- Plug-in Module replacement - easy mounting
- Programmable RPM activated outputs (2), can be used for nitrous activation, shift light, auto shifter or boost control

### Non-Programmable Ignition features:

(No P listed. Dyna and Sudco part numbers only)

- Improved timing curves
- Higher rev limits
- Removed reverse rev limit
- Overrides belt indicator for full performance at all times
- Increased spark energy
- Improved throttle response
- Easier starting
- Plug-in Module replacement - easy mounting



## Dyna FS Programming Kit

The Dyna FS programming kit includes everything you need to reprogram Dyna FS programmable ignition. Easy to understand interface, simple saving, recalling and printing of curves and quick reprogramming of the ignition make this the most user friendly programmable ignition software available. The Dyna kit includes the software to reprogram all available Dyna FS programmable Ignition models and the programming cable.

**This kit is not recommended for inexperienced tuners.**

Dyna FS Programming Kit DFSPK-1 **618-990**



## Dyna Shift Minder System

Ruggedly constructed and rigorously trade tested for bullet-proof reliability. The Dyna Shift Minder System consists of a shift light and a control module. Adjustable to any of the 64 different RPM settings with a 125 RPM increment between settings. This control module can also be used to activate other systems, such as an air shifter solenoid or nitrous injection system. Sold each.

Dynatek No.	Order No.
DSMS-4 (4-cylinder models.)	618-811
DSMS-2 (2-cylinder models)	618-810



## Dyna RPM Limiter

Dyna Rev Limiters effectively prevent your engine's rpm from exceeding a pre-determined limit that is totally user adjustable from 6,000 RPM to 12,000 RPM. DRL-200/300 - A single high RPM limiter continuously adjustable from 6,000 RPM to 12,000 RPM. DRL-400 - A two stage launch RPM limiter and high RPM limiter which is clutch switch activated. Launch limit is adjustable from 3,000 RPM to 10,750 RPM and over rev limit is adjustable from 10,000 RPM to 13,750 RPM. Both ranges are adjustable in 250 RPM increments. All Dyna RPM Limiters carry a 1 year factory warranty. Sold each.

Description	Dynatek No.	Order No.
Inductive RPM Limiter (upgrades the DRL-200)	DRL-200/300	618-795
Magneto CDI RPM Limiter	DRL-300CDI	618-794
2 Stage Rev Limiter	DRL-400	618-796
2 Stage Rev Limiter H-D	DRL-400HD	618-797

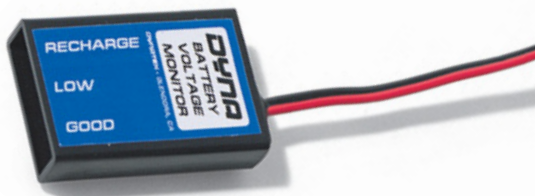

## Dyna Voltage Monitor

The Dyna Voltage Monitor is a necessity for any battery ignition vehicle which does not have a charging system. "Total Loss" ignition systems are typical of racing bikes and race cars that depend on the battery voltage only for proper operation. The Voltage Monitor will give a clear indication of battery condition with a quick glance at the three LED indicators. Sold each.

Dynatek No.	Order No.
DVM-1	618-801



## Dyna Charge Monitor

The Dyna Charge Monitor is a valuable addition to any vehicle with a battery powered ignition and charging system. 3 LED's monitor charging system status and will alert you in event of over-charging. Sold each.

Dynatek No.	Order No.
DCM-1	618-800

## PC Racing Engine Hour Meter

Automatically records and displays your engines accumulated run time, so oil changes, piston, rings, valves, spark plugs, etc. can be serviced at the correct maintenance schedule. The correct schedule saves costly engine damage from service neglect. Motominder can also save money from servicing too frequently. The smallest engine hour meter available (approximately 1" x 1.5") doesn't require additional mounting bracket and can be easily mounted by the peel and stick method to the frame or other convenient area. PC Racing is so confident that motominder is the most reliable engine hour meter available. It is backed by a 2-year manufacturer's replacement warranty.

Works with all Gas Engines.

PC Racing No.	Order No.
PCMM1	945-130



# Handlebar Switches & Horns



721-710



721-711



950-280



950-281

## Handlebar Switches

K&S offers a variety of universal handlebar switches, including D.O.T. approved for Dual Sport and Street/cruiser and switches for ATV/offroad use. See handlebar switch specifications for functions. Fits 7/8" handlebars. Sold each.

K&S Street Handlebar Switches-D.O.T. Approved for Street use (Specifications)

Turn Signal Right/Left	Headlight On-Off	Headlight Hi-Low	Headlight Passing	Horn	Kill	LED Indicator	Wire Length	Switch Width	DOT Approved	Order No.
Yes	Yes	Yes	Yes	Yes	No	No	25"	49mm	Yes	721-711
Yes	Yes	Yes	No	Yes	Yes	Yes	25"	45.5mm	Yes	721-710

K&S Universal Handlebar Switches-For Offroad use (Specifications)

Headlight On-Off	Headlight Hi-Low	Horn	Kill	Wires	Wire Length	Switch Width	Extra Terminals	DOT Approved	Order No.
Yes	Yes	No	Yes	6	18"	20.7mm	No	Not Required	950-278
Yes	No	No	No	2	16-1/2"	20mm	Yes	Not Required	950-280
				3	27-1/2"				
Yes	Yes	Yes	Yes	3	32"	43mm	Yes	Not Required	950-281
				6	27"				
No	No	No	No				Yes	Not Required	950-285

### Notes:

OEM Reference 35020-HN1-000. TRX type switch. [950-281](#)

OEM Reference 35150-KSC-671. 2 wire, direct plug type connection. Use for electric starter. [950-285](#)



## Economy Motorcycle Horns

Universal usage. Sold each.

Single Chrome, 12V/2.5 amp, 105 db, 7cm diameter **Order No. 950-270**

Single Black, 12V/2.5 amp, 105 db, 7cm diameter **Order No. 950-271**





## Replacement Kill Buttons

Direct plug-in into stock wiring harness. Sold each.

**Honda** Order No. [900-440](#)

2 wire plug-in, male and female connector with round eyelet connector/green wire. CR80R/CR125R/CR250R/CR500R 2-stroke



## Brake Light Switch

Universal hydraulic brake light switch. Use with high performance master cylinder without integral brake light switch. (10mm)

Order No. [950-275](#)



**Kawasaki** Order No. [900-441](#)

2 wire plug-in-male and female connectors  
KX60/KX80/KX85/KX100 2-stroke  
KX125/KDX200/KX250/KX500 2-stroke



## Racers Kill Switch

Normal Position: Open circuit.  
Activated: Tether pulled - circuit closed.  
Wire Length: 1st wire 24", 2nd wire 35".  
Tether kill switch. Sold each.

Order No. [900-444](#)



**Suzuki** Order No. [900-442](#)

2 wire plug-in, male connector and round eyelet connector  
RM80/RM85/RM125/RM250/RMX250 2-stroke



**Yamaha** Order No. [900-443](#)

2 wire plug-in male and female connectors  
YZ80/YZ85/YZ125/YZ250/YZ400/YZ490 2-stroke



# Bulbs & Fuses, Turn Signals, Taillight & ATV Headlight

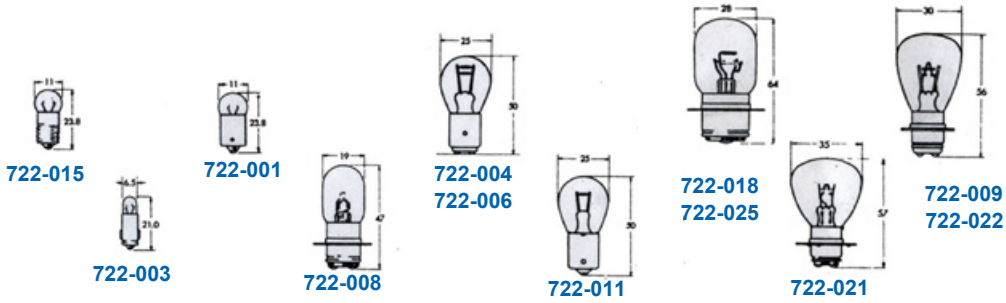

## Instrument, Tail Light & Turn Signal Bulbs

Sold box/10.

Description	Voltage	Order No.
Instrument Bulb	6V A62	722-001
Instrument Bulb	6V A1262	722-003
Instrument Bulb	6V A213	722-015
Tail Light Bulb	6V A4813C	722-004
Tail Light Bulb	12V A4879	722-006
Turn Signal Bulb	6V A4513	722-011

## Headlight Bulbs

Sold box/10.

Description	Voltage	Order No.
Headlight Bulb	12V A5676	722-021
Headlight Bulb	6V A7007	722-022
Headlight Bulb	6V A6867	722-025
Headlight Bulb	6V 13598	722-008
ATV Headlight. Bulb	6V 25/25	722-026
Headlight Bulb	12V A6982R	722-018
Headlight Bulb	12V A7025	722-009



## Motion Pro D.O.T. Tailplate & Light

D.O.T. approved for use in all 50 states. Durable Lexon light assembly. Perfect for dual-sport conversions. 12-volt bulb included.

**Made in the USA.**

Order No. **950-387**



## Glass Tube Fuses

Available in 25mm and 30mm lengths.

**Made in Japan.** Sold pk/5.

Length	Amp	Order No.
25mm Length	7 amp	723-001
	10 amp	723-002
	15 amp	723-003
30mm Length	7 amp	723-006
	8 amp	723-010
	15 amp	723-008
	30 amp	723-009



## Universal Turn Signals

D.O.T. approved for USA and "E" European approved. Heavy duty flexible stem is suitable for Street, Dual Sport and Scooters. Mounting is universal with wiring to fit most models. Use them to make your offroad model street legal. Sold in pairs.

Order No. **721-700**



## ATV Headlight (Closeout)

**Made in Japan. Not eligible for return.**

**Before ordering, make sure unit is compatible for your application.**

Description	Order No.
Square ATV Headlight 12V 60/60	722-500
Square ATV Headlight 12V 60/60	722-509



- ††† AGM was formerly referred to as GRT.
- † The YTX20 series batteries may be used as an optional upgrade, but some modification to the hold down may be necessary. See Battery side panel for retrofit cautions.
- †† Top and front terminal mounts only.
- (1) Some modification to the hold down/battery tray may be necessary. Battery must be rotated for correct polarity.
- (2) Eliminates need for sensor (needs to be disabled).

## Battery Cross Reference Chart

MAINTENANCE FREE (AGM †††)	YUMICRON CX	YUMICRON	CONVENTIONAL
_____	_____	6YB11-2D	6N11-2D
_____	_____	YB5L-B	12N5-3B
_____	_____	YB7L-B	12N7-3B
_____	_____	YB7-A	12N7-4A
_____	_____	YB9-B	12N9-4B-1
_____	_____	YB9L-B	12N9-3B
_____	_____	YB9L-A2	12N9-3A-1
_____	_____	YB10L-A2	12N10-3A-2
_____	_____	YB10L-B	12N10-3B
_____	_____	YB12A-A	12N12A-4A-1
_____	_____	YB14L-A2	12N14-3A
YTX20-BS †	YB16-B-CX	YB16-B	_____
YTX20L-BS †	YB16HL-A-CX	_____	_____
YTX20L-BS †	_____	YB16L-B	12N16-3B
YIX50L-BS †† (1)	_____	50-N18A-A	_____
YIX50L-BS ††	Y50-N18L-A-CX	Y50-N18L-A	_____
YIX50L-BS	_____	Y50-N18L-A3	_____
YIX50L-BS †† (2)	_____	SY50-N18L-AT	_____
YIX30L (Wet)	_____	YB30L-B	_____

## Battery Cross Reference Chart

OEM.	Order No.	OEM	Order No.	OEM	Order No.	OEM	Order No.
6N11-2D	<a href="#">201-0550</a>	6N6-3B-1	<a href="#">201-0470</a>	CB12A-B	<a href="#">201-1820</a>	CB9-B	<a href="#">201-1670</a>
6N11-4D	<a href="#">200-039</a>	12N10-3B	<a href="#">201-1170</a>	CB12AL-A	<a href="#">201-1830</a>	CB9L-A2	<a href="#">201-1650</a>
6N12A-2C	<a href="#">200-044</a>	12N11-3A-1	<a href="#">201-1190</a>	CB12B-B2	<a href="#">201-1870</a>	CB9L-B	<a href="#">201-1690</a>
6N12A-2D	<a href="#">201-0630</a>	12N12A-4A-1	<a href="#">201-1250</a>	CB14-A2	<a href="#">201-1910</a>	HCB16A-A	<a href="#">201-2110</a>
6N2-2A	<a href="#">201-0010</a>	12N14-3A	<a href="#">201-1270</a>	CB14-B2	<a href="#">201-2030</a>	WP12-B	<a href="#">201-3350</a>
6N2-2A1	<a href="#">200-002</a>	12N16-3B	<a href="#">201-1290</a>	CB14L-A1	<a href="#">201-1970</a>	WP14-B	<a href="#">201-3450</a>
6N2-2A-3	<a href="#">201-0060</a>	12N24-3	<a href="#">201-1350</a>	CB14L-A2	<a href="#">201-1990</a>	WP14L-2	<a href="#">201-3460</a>
6N2-2A-4	<a href="#">201-0070</a>	12N5.5-3B	<a href="#">201-0850</a>	CB14L-B2	<a href="#">201-2000</a>	WP14L-B	<a href="#">201-3470</a>
6N2-2A-8	<a href="#">200-053</a>	12N5.5-4A	<a href="#">201-0870</a>	CB16AL-A2	<a href="#">201-2090</a>	WP16-B	<a href="#">201-3480</a>
6N2A-2C	<a href="#">201-0130</a>	12N5.5A-3B	<a href="#">201-0910</a>	CB16B-A	<a href="#">201-2180</a>	WP16L-B	<a href="#">201-3500</a>
6N2A-2C-3	<a href="#">201-0150</a>	12N5-3B	<a href="#">201-0810</a>	CB16B-A1	<a href="#">201-2160</a>	WP50-N18L-A	<a href="#">201-3600</a>
6N4-2A	<a href="#">201-0190</a>	12N5-4B	<a href="#">201-0830</a>	CB16L-B	<a href="#">201-2190</a>	WP50-N18L-A3	<a href="#">201-3610</a>
6N4-2A-4	<a href="#">201-0230</a>	12N7-3B	<a href="#">201-0930</a>	CB18-A	<a href="#">201-2130</a>	WP5L-B	<a href="#">201-3150</a>
6N4-2A-5	<a href="#">201-0250</a>	12N7-4A	<a href="#">201-0950</a>	CB18L-A	<a href="#">201-2150</a>	WP7A-B	<a href="#">201-3190</a>
6N4-2A-8(6)	<a href="#">201-0270</a>	12N9-3A-1	<a href="#">201-1030</a>	CB2.5L-C	<a href="#">201-1430</a>	WP7L-B	<a href="#">201-3200</a>
6N4A-4D	<a href="#">201-0290</a>	12N9-3B	<a href="#">201-1050</a>	CB2.5L-C-1	<a href="#">201-1450</a>	WP9-B	<a href="#">201-3250</a>
6N4B-2A	<a href="#">201-0310</a>	12N9-4B-1	<a href="#">201-1070</a>	CB3L-A	<a href="#">201-1470</a>	WPH16-B	<a href="#">201-3490</a>
6N4B-2A-3	<a href="#">201-0330</a>	B38-6A	<a href="#">200-070</a>	CB3L-B	<a href="#">201-1480</a>	WPX20L-B	<a href="#">201-3520</a>
6N4C-1B	<a href="#">201-0370</a>	C50-N18L-A	<a href="#">201-2310</a>	CB4L-A	<a href="#">201-1520</a>	WPX4L-B	<a href="#">201-3100</a>
6N5.5-1D	<a href="#">201-0390</a>	C50-N18L-A3	<a href="#">201-2320</a>	CB4L-B	<a href="#">201-1530</a>		
6N6-1B	<a href="#">201-0430</a>	CB10L-A2	<a href="#">201-1750</a>	CB5L-B	<a href="#">201-1550</a>		
6N6-1C	<a href="#">200-056</a>	CB10L-B	<a href="#">201-1770</a>	CB7-A	<a href="#">201-1570</a>		
6N6-1D-2	<a href="#">201-0510</a>	CB10L-B2	<a href="#">201-1780</a>	CB7C-A	<a href="#">201-1620</a>		
6N6-3B	<a href="#">201-0450</a>	CB12A-A	<a href="#">201-1810</a>	CB7L-B	<a href="#">201-1610</a>		



## California Gold Original Formula Carnauba Cleaner Wax

Original Formula Carnauba Cleaner Wax is designed to be the one-step plan for paint preservation. This special Carnauba Cleaner Wax is formulated to clean and protect in just one application. We used the same Brazilian #1 yellow carnauba that makes our Pure Carnauba Wax so special, and combine it with a light polish that will smooth minor flaws and make your paint snap. Carnauba Cleaner Wax is especially effective on fiberglass and gel coats. Available in long lasting, easy-to-apply liquid or paste. Sold in 16 oz. bottle.

Order No. [800-736](tel:800-736)



## California Gold Natural Formula Pure Carnauba Wax

This is the final step on the path to a beautiful finish. Mothers Pure Carnauba Wax is made with the finest Brazilian #1 yellow carnauba for superior shine and protection. Natural Formula is non-abrasive, so use as much as your paint needs, as often as you like. You can also apply more than one coat to keep your efforts well protected. For unsurpassed shine, depth and protection, trust Mothers Ultimate Wax System. Sold in 16 oz. bottle.

Order No. [800-737](tel:800-737)

## California Gold Showtime Instant Detailer

Treat your paint to a Showtime sparkle that's wet and striking. Whether you want to clear a layer of dust or prepare for the judges, use Showtime Instant Detailer. This unique formula will clean off fingerprints, smudges, dust, hide minor imperfections and spider webbing. Showtime is designed with color enhancers and shine fortifies, ready whenever you need your ride to look freshly detailed. Sold in 16 oz. spray bottle.

Order No. [800-784](tel:800-784)

Keep a couple of dry towels handy as Showtime shines best with a dry towel. Be sure to remove Showtime before it evaporates. Showtime can be applied in direct sunlight as long as the surface is not excessively warm.



## California Gold Scratch Remover

There are areas of your paint's finish that see more abuse than others: on the edges of doors and the trunk lid, around the door handles, keyholes, at the hood latch, etc. What you need is a scratch remover. Mothers has one. Our Scratch Remover works on any sort of paint, any sort of finish, to help restore high mileage paint and remove surface scratches. This is a true polish-be sure to chase it with the standard regimen of waxing to properly seal and protect. Sold in 8 oz. bottle with drip cap.

Order No. [800-788](tel:800-788)



## Preserves Protectant

Preserves and protects for 30 days! Our Mothers Preserves Protectant is available in traditional spray-on liquid or as convenient, ready-to-use wipes. Preserves is a penetrating UV blocker, effective on rubber, vinyl, plastic and fiberglass. Constructed to recondition and maintain the original condition and appearance of dashboards, vinyl, bumpers, trim, tires and more. Sold in 16 oz. spray bottle.

Order No. [800-720](tel:800-720)







## California Gold Chrome Polish

Thick, rich and easy-to-use, gently deep cleans and brightens chrome bumpers, wheels, trim and accessories, advanced polymers help protect against fingerprints, spotting, rust and corrosion, polish will not streak, scratch or smear, safely cleans and protects glass and mirrors Sold in 12 oz bottle

Order No. **800-716**



## Billet Metal Polish

Mothers Billet Metal Polish takes our world famous metal polish technology to a whole new level. State of the art cleaners and cutting edge formulation give your billet, forged and finely cast aluminum, brass and other polishable metals the absolute finest finish available-guaranteed. If you've spent big bucks on quality metal accessories, step up to a polish worthy of your investment. When using Billet Metal Polish on aluminum, a black residue should appear on the applicator. If it doesn't, stop polishing immediately. The metal is probably clear coated and should be maintained with Mothers Clear Coat Wheel Polish. Sold in 4 oz. tub.

Order No. **800-712**



## Plastic Renew™

- ATV and motorcycle plastic restoring
- Gives your ATV or motorcycle that showroom shine
- Restores at least four complete bikes and two ATV's
- Works on any color

Plastic Renew is a complete plastic restoring kit. 3 to 4 coats of Plastic Renew™ brings out the brilliant color and shine of new plastic. With Plastic Renew™, you don't have to worry about building up or discoloring. This product will not come off from normal washing. If your plastic gets scratched again, just follow the same procedure to restore that like-new shine. Typical motorcycle restoration will only require about one-quarter and ATV about one-half the chemical in this kit.

Order No. **945-090**



## Mag & Aluminum Polish

This is Mother's legendary metal polish. Mother's secret formula balances a brilliant shine with easy use for aluminum wheels and parts, brass, alloys and accessories. Application is just a matter of a clean cloth and a little elbow grease. Mothers Mag & Aluminum Polish is strong enough to put a shine to the most neglected metals and gentle enough to use on a regular basis. Sold in 5 oz. tub.

Order No. **800-710**



## PJ1 Renew and Protect

Non oily surface treatment for plastic, vinyl, wood, treated leather and rubber

- Ideal for seats, tires, plastic body parts, etc.
- Unique super silicone formula provides a penetrating moisturizer
- Restores original appearance

Available in 8 fl. oz. and 16 fl. oz. bottle

Description	Order No.
8 fl. oz. bottle	<b>899-090</b>
16 fl. oz. bottle	<b>899-091</b>

# Three Bond Sealants, Thread Locker & HV350



## Three Bond Plastic Repair Kit TB1743

This plastic repair kit quickly and economically repairs broken and cracked hard to bond plastics, fairings, mounting tabs, personal watercraft snowmobile hoods and brackets. Plastics such as Polypropylene, Polyethylene, Polyacetal and ABS are now possible to repair. Simple to use and no mixing required. Kit includes: glue, primer, accelerator, glue remover, sand paper, fiberglass and application sticks.

Description	Order No.
Plastic Repair Kit TB1743	800-150
Glue only TB1743A, 1 oz. tube	800-151



## Three Bond Anaerobic Thread Locks

No matter what locking properties are required, one of Three Bond's thread lock products will get the job done. All of Three Bond's thread lock inhibit the development of rust, leaks, corrosion and are not affected by oils, chemicals, salt water, various gases or organic solvents.

Description	Three Bond Ref.	Order No.
Low Strength: Frequent Removal	TB1342 10ml	800-120
Medium Strength: Bearing & Stud	TB1333 10ml	800-124
High Temp: Extreme Temperature	TB1360 10ml	800-128



## Three Bond Spoke Tight TB1361D

Drip control nozzle. Sets spoke nipples snug and protects threads from rust and corrosion. Sold in .34 oz. bottle.

Order No. 800-135



## Thread Locker

LOCK. RETAIN. SEAL. GASKET. Thread Locker compounds perform at high temperatures, prevent corrosion, and resist water, oils, hydrocarbons and more. They also withstand vibration, improve load distribution and act as a lubricant during assembly. A durable plastic seal cures in the absence of air when activated by a metal component or primer.

Description	Order No.
Thread Locker, Medium-Strength Blue, 10 ml	800-560



## Three Bond Griplock TB1501C

Keep grips in place without damaging the rubber. Use on ATV's, motorcycles, snowmobiles and personal watercraft. Sold in 1 oz. tube.

Order No. 800-155



## HV-350™ Adhesive

This multipurpose adhesive virtually outperforms any glue, epoxy or silicone on the market today. "HV" stand for high vibration. Its tremendous elasticity allows it to work in high vibration applications, such as repairing a broken tail light. HV-350™ is sandable, paintable, highly abrasion resistant and flexible. This glue can be used on highly porous surfaces such as foam, rubber, and fiberglass. It could also be used on non-porous surfaces such as metal, glass and plastic. Sold in 3.35 oz. tube.

Order No. 800-500

VINTAGE  
INTAKE  
ENGINE  
SUSPENSION  
CONTROL  
ELECTRICAL  
CHEMICAL  
TOOLS  
WATERCRAFT



## White Silicone Liquid Gasket TB1211

A free flowing, low viscosity, one compound RTV silicone rubber. Ideal for places where long seal is absolutely critical. Recommended for sealing flange surfaces and screw sections to prevent oil, water, gasoline and chemical leaks. Effective over a wide temperature range, - 76° to 482° (60° to 250° C). Tack free in 90 minutes; fully cured in 24 hours; attains optimum strength within 3 days. Recommended for ATV, automotive, motorcycle, snowmobile and personal watercraft engines. Sold in 3.5 oz. tube.

Order No. [800-212](#)



## Clear Silicone Liquid Gasket TB1212C

A low odor, fast setting, non slumping paste that cures at room temperature to a rubbery solid. This multi-purpose RTV silicone sealant can be used in numerous bonding and sealing applications such as pumps, gearboxes, marine cabins, windows and electrical boxes. Sold in 3 oz. tube.

Order No. [800-213](#)



## Case Sealant Liquid Gasket TB1184

A semi drying synthetic rubber liquid gasket which is resistant to oil, water, chemicals and gasoline. Application areas include sealing transmission case covers, 2-stroke crank cases, timing chain cases, side covers, 2-piece cylinders, clutch housing bolts and oil filter mounting surfaces. **Note:** Replaces TB1104.

Temperature range from 40° F to 302° F. Sold in 100 g. tube.

Order No. [800-215](#)



## Gasket Maker Gray TB1200GAU3Z **NEW**

RTV sealant (gray) high viscosity, gasket maker. OEM specified product with good elasticity. Temperature, and chemical resistant. Resists oil, water, coolants, and gasoline. Excellent as general purpose LGM with high resistance to heat and cold. Sold in 3.8 oz. tube.

Order No. [800-216](#)



## Gasket Maker Gray TB1217H **NEW**

This is a great LGM where difficult or loose fitting components are used. Can be loaded up-side-down and it's fast setting properties allow for assembly within seconds of application. It's high resistance to motor and gear oil make it an excellent choice for transmission and drive train assembly. Sold in 5.0 oz. cylindrical tube with applicator tip.

Order No. [800-218](#)



## Gasket Maker Black TB1207B **NEW**

One of the finest RTV LGM's available any where. It is particularly good with adhesion to both plastic and metal. The proprietary formulation features advanced elongation properties and is exceptional in uses where extreme vibration, torque, and heat are involved. Sold in 3.4 oz. tube.

Order No. [800-217](#)

# Sealants, Solvent 184, Anti-Seize & Gel Lube



## Hylomar Gasket Maker and Thread Sealant

Hylomar can be used as a dressing or a gasket maker. It is non-hardening and is impervious to chemicals such as fuels, oils and antifreeze. It makes an excellent dressing for any cut gasket where temperatures remain below 600° F. The product will form a gasket if used by itself when sealing a gap of less than 0.010 inch between precision machined surfaces. A Hylomar treated joint can be disassembled, inspected, and reassembled without reapplication. Sold in 100 gram tube and 250 ml. brush-cap can.

Description	Order No.
Valco Hylomar 100 gr Tube	800-530
Valco Hylomar 250 ml Brush-Cap Can	800-531

## Epoxy-Putty™

Epoxy-Putty is a steel reinforced, kneadable product that mixes like putty, bonds like epoxy, and hardens like steel. It is extremely tough and durable and adheres to a wide range of metals as well as PVC, plastic, ceramic, fiberglass, glass and wood. Epoxy-Putty sets up under water and is impervious to chemicals, and has a shelf life of three years. After one hour, it can be drilled, tapped, filed and machined. Cured Epoxy-Putty will withstand temperatures up to 500° F. Sold in 2 oz. clear cylinder with cap.

Order No. 800-540



## All-In-One RTV Silicone

Premium-grade RTV silicone that does it all. RTV silicone is oxygen sensor safe, has a low volatility rating, is usable from 80 °F to 600 °F, and is solvent resistant. Choose from Aluminum or Clear. Sold in 3.0 oz. tube.

Order No. 800-510



## Non-Metallic Anti-Seize

Non-Metallic Anti Seize lubricant contains no metals and is safe to use on stainless steel and other sensitive alloys. The compound is specifically designed to protect against galling, erosion and sealing. Non-metallic Anti Seize makes for easier disassembly. It can be used on pipe threads, pump and valve packing, low speed bearings, shafts, gears and cable or use as a dry film lubricant. Sold in 8 oz. can with brush.

Order No. 800-550



## Solvent 184™

Solvent 184 is a great cleaner of electrical contacts, brakes, alternators, electric motors, starters, machined surfaces and much more. It removes tar, wax and petroleum products, and may be used to prepare surfaces for application of sealants and adhesives. Solvent 184 is non-flammable, easy to use and comes in a non-aerosol can with a built-in nozzle cap that reduces waste. Sold in 16 oz. nozzle-top can

Order No. 800-555



## Gel Lube

Engine assembly is made easier, quicker, and cleaner with Valco's premier lubricant—GelLube™. GelLube sprays on thin and penetrates quickly—transforming into a heavy-duty, load-bearing, protective gel. GelLube does not drip, melt or shift when applied. GelLube bonds to metal surfaces and fills all small spaces and crevices on valve springs, cranks, cams, bearings and much more. Sold in 8 oz. can.

Order No. 800-565



### Gold Fire® Synthetic Blend Motor Oil

Racing Grade Motor Oil for 4-stroke engines.

- Single or multi cylinder applications
  - Formulated with anti-shearing agents and friction modifiers for wet clutch applications
- Sold in 1 lt. bottle.

Description	Order No.
10W40	899-010
20W50	899-012



### Silver Fire™ Pre-Mix Oil

Semi-synthetic 2-stroke pre-mix oil

- Competition grade semi-synthetic blend
  - Power and protection
  - Offers professional level protection at an amateur level price
- Sold in 1 lt. bottle.

Order No. **899-024**



### Gold Fire® Pro Pre-Mix Oil

Premium racing grade 2-Stroke Pre-Mix

- Competition grade synthetic pre-mix
  - Formulated for very high RPM conditions
  - Minimizes engine wear
  - Extraordinarily clean burning
  - Developed in conjunction with Kenny Roberts GP road race team under race conditions
- Sold in 1/2 lt. and 1 lt. bottle.

Description	Order No.
1/2 lt.	899-020
1 lt.	899-021



### Silver Fire™ Injector Oil

Synthetic blend 2-stroke injector oil.

- Specially formulated for oil injection systems
  - Great for non-competitive riding use
  - Offers professional level protection at an amateur level price
- Sold in 1 lt. bottle.

Order No. **899-026**

### Clutch Tuner Gear Oil

For non-motor wet clutch applications.

- Transmission Oil for 2-stroke competition motors and 4-stroke motors with separate transmissions/clutch assemblies
  - 75W for 125cc 2-stroke/250cc 4-stroke
  - 80W for 250cc 2-stroke/450cc 4-stroke
- Sold in 1 lt. bottle.

Description	Order No.
75W	899-030
80W	899-031





## Black Label Chain Lube

Optimized for non o-ring chains

- Penetrates deep in to the chain
- Lubricates pins, rollers, side plates and sprockets
- Reduces chain stretch and the requirement for frequent adjustments
- Protects chain against the elements
- Lowers operating heat
- Safe on o-ring chains but recommended for non o-ring chains

Available in 5 fl. oz. and 13 fl.oz. aerosol can.

### Description

- 5 fl. oz. aerosol can
- 13 fl. oz. aerosol can

### Order No.

- 899-001
- 899-002



## Blue Label Chain Lube

Optimized for O-Ring/X-Ring chains

- Clear formula won't fly off
- Lubricates pins, rollers, side plates and sprockets
- Reduces chain stretch and the requirement for frequent adjustments
- Protects chain against the elements

Available in 13 fl.oz. aerosol can.

Order No. **899-006**

## Fuel Injector & Carb Cleaner

Fuel system cleaner and treatment

- Keeps injectors and carburetors at peak performance for smooth and consistent power
- Removes fuel deposits and petroleum debris
- Safe for all leaded, unleaded and oxygenated fuels
- For 2 and 4 stroke engines.

Sold in 12 fl. oz. bottle.

Order No. **899-075**



## Cable Lube

Lubricant for control cables

- Extends cable life
- Cleans and lubricates
- Makes cable pull easier

Sold in 11 fl. oz. aerosol can.

Order No. **899-190**

## LPC-3® Penetrating Oil

Super rust busting penetrating lubricant

- Multipurpose lubricant
- Protects metal
- Displaces moisture

Sold in 11 fl. oz. aerosol can.

Order No. **899-191**

## Assembly Lube

Use on crankshafts, valve guides, cylinder walls, pistons, camshafts, etc. Synthetic and petroleum oil soluble.

Sold in 11 fl. oz. aerosol can.

Order No. **899-192**



## PJ1 Super Cleaner

Multi-application, non-residue, evaporating degreaser

- High pressure blasts
- Powerful solvent melts oil, carbon, grease and grime away
- Dries quickly, displaces moisture and leaves no residue

Sold in California Compliant 13 fl. oz. aerosol can.

Order No. **899-081**



## Foam Air Filter Oil

- Available in aerosol and liquid application formulas
- Petroleum and synthetic oil soluble

Description	Order No.
Foam Air Filter Oil, 13 fl. oz. aerosol can	899-067
Air Filter Kit	899-070

(Includes Foam Air Filter Oil 899-067 and Air Filter Cleaner 899-068)

## Fabric Air Filter Oil

- Aerosol Formula
  - Quick, easy application
- Available in 15 fl. oz. aerosol can.

Order No. 899-065

## Filter Cleaner

- Cleans fabric and foam air filters
  - Easy to use, spray on-wash off
  - Will not harm glues
- Available in 15 fl. oz. aerosol can.

Order No. 899-068



## Red Line Suspension Fluids

Red Line Suspension Fluids provide very good shear stability which means that they should not degrade with use. They change very little with temperature and will provide lower operating temperatures for the same viscosity when compared to conventional suspension fluids. They are also very low forming and provide good seal lubricity and antiwear properties. They can be blended together in any proportion to achieve an intermediate viscosity. For use in cartridge forks and motorcycle shocks. Sold in 16 oz. bottle.

Description	SAE Weight	Order No.
Like Water Suspension Fluid no	No SAE rating	900-860
Extra Light Suspension Fluid	2.5wt	900-861
Lightweight Suspension Fluid	5wt	900-862
Medium Suspension Fluid	10wt	900-863



## Cartridge Pro Fork Fluid

Meets or exceeds OEM specifications for Showa and Kayaba cartridge / twin chamber forks. Sold in 1 lt. bottle.

Order No. 899-060



## Fork Tuner Oil

For updating and adjusting fork systems.

- An effective and inexpensive method to "tune" conventional fork compression
  - For different rider weights and conditions
- Sold in 1/2 lt. and 1 lt. bottle.

Description	Order No.
2.5W, 1/2 lt. bottle	899-040
5W, 1 lt. bottle	899-043
7.5W, 1 lt. bottle	899-045
10W, 1 lt. bottle	899-047



## Flat Shield®

Prevents flat tires.

- Seals puncture holes up to 1/8" inch (6 millimeters)
  - Maintains up to 90 percent of pressure between puncture and sealing process
  - Harmless to rubber and coated metal wheels
  - Aids in balancing, won't affect patching
- Available in 8, 16, and 32 fl. oz. bottle.

Description	Order No.
8 fl. oz.	899-180
16 fl. oz.	899-182
32 fl. oz.	899-183



## Synthetic Motor Oils

Red Line's synthetic engine oils are designed to provide the highest protection, cleanliness and superior drain intervals with the lowest friction for your gasoline, diesel, motorcycle or marine engine. Redline's products are unique because they contain polyol ester base stocks, the only lubricants which can withstand the tremendous heat of modern jet engines. Sold in quart bottles.

Description	Order No.
5W30	900-804
10W30	900-800
10W40	900-801
15W50	900-802
20W50	900-803

## High Performance Motorcycle Oils

Red Line's High Performance Motorcycle Oils are fully-synthetic formulas specifically created for the high demands of the latest high-revving four-stroke motocross bikes, ATVs, Sportbikes, and V-Twins. Available in popular viscosities of 10W30, 10W40, 20W50, and 20W60, these ester-based products contain the anti-wear chemistry demanded by mechanics and enthusiasts. This oil also features lower levels of friction modifiers for superior wet clutch operation. Excellent thermal stability, oxidation resistance, cleanliness, and ability to lubricate hot metal make Red Line High Performance Motor Oil a superior lubricant. Recommended for JASO MB, API SJ, SG, & SH. Sold in quart bottles.

Description	Order No.
10W30	900-880
10W40	900-881
20W50	900-883
20W60HD	900-805



## Two-Stroke Racing Oil

Red Line's popular two-stroke lubricants contain base oil which have the highest film strength and greatest affinity for hot metal. Because Red Line is a superior high temperature lubricant, it can be used at lower fuel to oil ratios, increasing power and providing excellent scuff protection and cleanliness. Where many two-stroke oils are recommended to run 32:1, many Red Line customers often mix at a leaner 40:1. Red Line provides the lubricating cleanliness, with low carbon residue that dramatically reduces plug fouling and smoke. Red Line provides special protection for formulated fuels. Dyno proven to make more power over longer periods of operating time. Sold in 16 oz. and gallon bottles.

Description	Qt	Order No.
2-Stroke All Sport	16 oz	900-833
2-Stroke Alcohol	16 oz	900-848
2-Stroke Race	16 oz	900-830
2-Stroke Kart	16 oz	900-831
Watercraft & Injection	1 gallon	900-854
2-Stroke Race	1 gallon	900-829
2-Stroke Kart	1 gallon	900-832



## Synthetic Racing Oil

Red Line's racing synthetic oils are made with the most thermally stable synthetic base stocks available and provide the best high-temperature lubrication and a higher film strength than any petroleum or synthetic on the market today. Although Red Line racing oils are categorized as "straight grades", their low-temperature properties make them exceptional multigrade, allowing 2-4% more power than an oil of similar viscosity, while providing much more protection. Each reduction in viscosity grade allows 1-2% more power. To reduce the chance of detonation, Red Line race oils contain very few detergents and are not recommended for street use. Sold in quart bottles.

Description	Order No.
20 WT SAE (5W20)	900-810
30 WT SAE (10W30)	900-811
40 WT SAE (15W40)	900-812
50 WT SAE (15W50)	900-813





## ShockProof™ Gear Oil

A unique lubricant containing a suspension of solid microscopic particle as an extreme pressure agent—unique solid dispersion which cushions gear teeth to help prevent tooth breakage and allows the use of lower viscosities. The viscosity characteristics allow the lubricant to resist throw off and provide a film thickness greater than an SAE250 grade, with the same low fluid friction as with 80W140. Recommended for heavily-loaded racing differentials and transmissions, Off Road racing and problem gearboxes. Offers a “best of both worlds” balance of relatively low drag and utmost in protection. Sold in quart bottles.

Description	Order No.
Superlight 70W90	900-820
Lightweight 75W/140	900-821
Heavyweight 75W/250	900-822
Gear oil for Automotive Differentials 75W/90	900-823

## SI-1 Complete Fuel System Cleaner

SI-1's injector and valve detergent is a concentrated package of the most powerful high-temperature detergents available to clean gasoline fuel injectors or carburetors, intake valves and combustion chambers. and can clean injectors to nearly 100% efficiency in one treatment. The cleansing effect on injector deposits can raise fuel economy 12% or even greater depending on the condition of the injectors. SI-1 also contains detergents and a synthetic upper cylinder lubricant which will help clean pollution control valves and can reduce octane requirements by two numbers. SI-1 also protects the fuel system from rust. Sold in 15 fl. oz. bottle.

Order No. **900-870**



## Water Wetter®

Water Wetter is a unique wetting agent for cooling systems which reduces coolant temperatures by as much as 30° F. This liquid product can be used to provide rust and corrosion protection in plain water for racing engines, which provides much better heat transfer properties than glycol-based antifreeze. Or it can be added to new or used anti-freeze to improve the heat transfer of ethylene and propylene glycol systems. Designed for modern aluminum, cast iron, copper, brass and bronze systems. Compatible with all antifreezes, including the latest long-life variations. Sold in 12 fl. oz. bottle.

Order No. **900-842**



## 4-Stroke Alcohol Fuel Lube

Red Line Alcohol Lube is designed to combat corrosion and water absorption within the fuel system of alcohol burning racing engines. This specifically developed product will provide lubrication for all system components as well as the upper cylinder, resulting in a much longer component life when compared to straight alcohol. Sold in 12 fl. oz. bottle.

Order No. **900-844**

## 80W Motorcycle Gear Oil with ShockProof™

Designed for applications like two-stroke bikes, shifter karts, the CRF250/CRF450 transmission. Used where an 80W oil is called for, ShockProof's microscopic solid medium provides cushioning between gear teeth, while maintaining lower drag. Reduces the thinning effect from high temperatures. Sold in quart bottle.

**Description**  
80W Gear Oil with ShockProof

**Order No.**  
**900-824**



## Assembly Lube

Provides three-times greater film strength than conventional black Molybdenum Disulfide greases and will not clog oil filters. This product clings to all surfaces and is an excellent rust inhibitor, allowing the storage of parts for years. A thin film of protection is all that is required when mating parts. Sold in 4 oz. tub.

Order No. **900-840**



# K&N Filter Oil, Rustol & Chemical Accessories



## Rustol

Rustol gives excellent results with little or no work required. It is safe and non-corrosive to all metals, rubber coatings and paint. While destroying existing rust, it forms a protective bond that prevents raw rust from forming later. Rustol is odorless unlike conventional rust removers and is shipped in a concentrated form. Believe it or not, the same batch of Rustol can be used many times. Note: Rustol should be diluted according to instructions before use. Available in 1 quart, 1 gallon, and 20 liter.

Description	Order No.
1 quart bottle	800-250
1 gallon bottle	800-252
20 liter bottle (bag in a box)	800-253

## K&N Filtercharger® Oil

The only oil specially formulated to work with in combination with the cotton fabric in K&N Filtercharger® elements providing outstanding air filtration. When used as directed, it quickly penetrates the filter pleats, where it remains suspended in the cotton fabric unit until the element is cleaned with K&N Air Filter Cleaner.

Air Filter Oil	K&N No.	Order No.
6-1/2 oz. aerosol can	99-0504	005-530
12 oz. aerosol can	99-0516	005-532
8 oz. squeeze bottle	99-0533	005-534

## Air Filter Cleaner & Degreaser

32 fl. oz. squirt bottle 99-0621 005-520  
The only cleaner formulated for K&N Filtercharger® elements. **Note:** Not to be used on polished anodized aluminum.



## Red Line Super Cool with Water Wetter

Performance coolant with Water Wetter. Super Cool with Water Wetter is a pre-mixed coolant for motorcycles, ATV's, karts, generators and other small water-cooled engines. This product doubles the wetting ability of water to improve heat transfer and reduce cylinder head temperature. Provides excellent rust and corrosion protection for modern cast iron, aluminum and brass systems. Sold in 1/2 gallon container.

Order No. 900-843



## K&N Recharger® Filter Care Service Kit

This six step maintenance system is designed to recharge any K&N Filtercharger® Air Filter. It restores air flow efficiency so your Filtercharger® performs like new.

Recharger® Filter Care Service Kit	K&N No.	Order No.
Kit includes 6-1/2 oz. aerosol spray oil, 12 oz. filter cleaner and service decal.	99-5000	005-540

Recharger® Filter Care Service Kit	K&N No.	Order No.
Kit includes 8 oz. squeeze oil, 12 oz. filter cleaner and service decal. Same as 005-540 except has squeeze bottle instead of spray can.	99-5050	005-541

VINTAGE INTAKE ENGINE SUSPENSION CONTROL ELECTRICAL CHEMICAL TOOLS WATERCRAFT



949-100

949-101

## Plastic Oil Filler Cans

Available in 1 and 2 liter size. Sold each. *Made in Japan.*

Description	Order No.
1 Liter	949-100
2 Liter	949-101



949-110

949-111

## Measuring Cylinders

Available in 100cc and 200cc plastic beaker. Sold each. *Made in Japan.*

Description	Order No.
100cc	949-110
200cc	949-111



## Charlie's Soap

Charlie's Soap for motorcycles, is a very effective, yet mild product for cleaning all motorcycles. Safe for all plastics, decals, and expensive paint jobs. Use full strength for dirt bikes or dilute 10:1 for street bikes. Sold in 17 oz. bottle.

Order No. **800-300**



## Redline Super Trick Funnel

Oddly shaped funnel allows pouring of oil or coolant around bodywork to reach hard to get to filler openings. Pours in both horizontal and vertical positions. Sold each.

Order No. **900-846**



## White Lithium Grease

Multipurpose White Lithium Grease™ is a quality white grease (NLGI#1) specifically designed to protect engine parts. The exceptional consistency of this grease creates ease in application for all engine parts including valves, bearings, crankshafts, wheels and nut assemblies and all other areas where metal-metal contacts occur. Sold in 8 oz. tube.

Order No. **800-545**



## Synthetic CV-2 Grease

Red Line CV-2 Grease is designed to withstand the extreme temperatures and pressures which occur in high-performance wheel bearings and CV-joints. The excellent high-temperature stability, extreme-pressure protection, and water resistance enables it to out-perform even the best conventional or synthetic greases. Red Line CV-2 Grease can be used in a wide range of applications at temperatures ranging between -100° F to 500° F and provides good oxidation and corrosion resistance, low evaporation and oil separation, and has a minimum effect on rubber seals. Sold in 14 oz. tub.

Order No. **900-850**



5mm Rigid Brass Hose Adapters



Flex Rigid Hose Adapters

## Sync Pro Carburetor Tuner

New mercury free design carburetor tuner. Rugged, impact-resistant ABS enclosure with convenient storage area. For use with any 2, 3, or 4-cylinder, 4-stroke motorcycle. Tuner is spill proof and can be stored in a horizontal or vertical position. Includes manometer fluid, hoses, 5mm adapters, in-line restrictors and instructions. **Made in the U.S.A.**

Order No. [950-402](#)

## Accessories for Sync Pro Carburetor Tuner

Description	M.P. No.	Order No.
<b>5mm Rigid Brass Hose Adapters for Honda &amp; Suzuki (set of 4)</b>	08-0013	<a href="#">950-410</a>
<b>6mm Rigid Brass Hose Adapters for Yamaha (set of 4)</b>	08-0040	<a href="#">950-409</a>

Includes 2 long and 2 short adapters with restrictors.

<b>5mm Permanent Hose Adapters (each)</b>	08-0216	<a href="#">950-720</a>
<b>6mm Permanent Hose Adapters (each)</b>	08-0217	<a href="#">950-721</a>

Designed for permanent installation into the vacuum ports on the intake manifold. Once installed, the hoses can be routed to an accessible location. Reduces time for carburetor synchronization.

<b>5mm Flex-Rigid Hose Adapters (each)</b>	08-0201	<a href="#">950-715</a>
<b>6mm Flex-Rigid Hose Adapters (each)</b>	08-0202	<a href="#">950-716</a>

Allows adapter to be molded around awkward manifold connections. Rigid enough for easy hose connection. 12cm length.

<b>5mm Permanent Brass Adapters (each)</b>	08-0218	<a href="#">950-722</a>
<b>6mm Permanent Brass Adapters (each)</b>	08-0219	<a href="#">950-723</a>

Brass adapter with rubber cap. Designed for permanent installation into the vacuum ports. Eliminates the need to install adapters before every synchronization.



Permanent Hose Adapters



Permanent Brass Adapters w/Rubber Cap

## Carb Synchronizer

Complete sets come with vacuum gauges, hoses, adapters, mounting plate and instructions.

Description	Order No.
2-Gauge Set	<a href="#">950-205</a>
4-Gauge Set	<a href="#">950-206</a>





950-450



950-451

## Motion Pro Auxiliary Gas Tanks

These impact resistant, graduated auxiliary gas tanks take the place of the original gas tank when performing carb synchronizing. Each gas tank includes four feet of 1/4" fuel line and inline brass petcock.

**Auxiliary Gas Tank** Order No. **950-450**  
Use with carbureted applications. Capacity is 200cc or 1/2 gallon.

**Deluxe Auxiliary Gas Tank** Order No. **950-451**  
Redesigned for use on fuel injected applications. Can also be used with carbureted applications. Has fuel return attachment on top cap. Capacity is 200cc or 1/2 gallon.



950-700



950-701



950-702



950-707

## Motion Pro Inline Fuel Valves

Ideal for use on ATV's and other vehicles where inline fuel control is necessary. Not recommended for engines above rate size.

Description	Order No.
Inline Fuel Valve for 3/16" I.D. Fuel Valve, up to 200cc	950-700
Inline Fuel Valve for 5/16" I.D. Fuel Valve, up to 300cc	950-701
Inline Fuel Valve for 1/4" I.D. Fuel Valve, up to 300cc	950-702
Inline Fuel Valve with 1/4" threaded pipe and 1/4" barb end	950-707



## VamPLIERS™ NEW

The VamPLIERS are an all-purpose set of pliers that feature a unique design to remove stubborn fasteners. The handles are very ergonomically correct, and they are covered in a tough bright red polymer that is not only really visible, but also solvent resistant. It will shield you from an electrical shock if you hit an unexpected source of power. This is an exceptionally well-made set of pliers crafted from treated top-quality carbon steel that have a spring-loaded operation to open them so you don't have to manipulate the tool both ways.

Order No. **950-305**



## Sudco Carb Vacuum Fitting Cap

Replacement part for Mikuni RS Smoothbore carburetors. This rubber plug is found on many Yamaha models. *Made in Japan.* Sold each.

Order No. **002-646**



## K&L Carb Holder Rubber Plugs

Universal rubber plug has many uses. Sold pk/5. *Made in Japan.*

Order No. **005-860**

# Carburetor Tools



## Motion Pro Pilot Screw Adjusting Tool

Designed for those hard-to-reach air/fuel mixture screws on most multi-cylinder motorcycles. 110° angled head extends reach 1". Length is 17" with a straight-slot blade tip. Sold each.

Order No. [950-406](#)

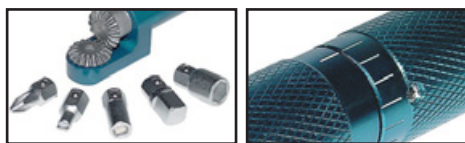

## Motion Pro 90-Degree 1/4" Hex Driver

Gear driven, 1/4" hex driver set is precision made of aircraft grade aluminum and stainless steel. Designed for use on hard-to-reach air/fuel screws on multi-cylinder motorcycles. Can be used with any 1/4" or 6mm hex bits. Includes straight slot, phillips, d-shape pilot screw bit, 6mm hex jet bit & 1/4" - hex - 1/4" drive bit.

Order No. [950-478](#)

### Description

Bit, D-Shape for 950-470

### Order No.

[950-789](#)



## Motion Pro Carb Adjusting Tool

Designed for use on Honda, Kawasaki, Suzuki, and Yamaha. Fits both Mikuni and Keihin carbs with 8mm hex nut and screw driver slot adjusting bolt. This tool make those hard to reach carb adjustments easy and safe. Length is 11". Sold each.

Order No. [950-405](#)

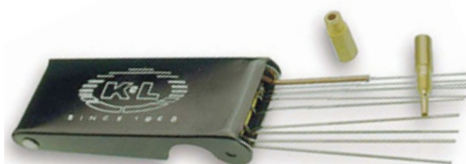

## K&L Carb Cleaner Wire Set

14 piece wire set with spiral knurling. Use for cleaning popular size jets and carb body holes/passages.

Order No. [950-203](#)



## Motion Pro FCR Carb Tool

Longer bits make this set ideal for reaching into recessed cavities to adjust Keihin FCR carburetors. Cap compartment will hold a few spare jets. Ideal for trail riders and garage mechanics. Set includes three bits, 6mm hex for main jets, long reach straight slot for pilot jets and a 3mm Allen for float bowl removal. Sold as a set.

Order No. [950-403](#)



## Motion Pro Main Jet Wrenches

These high quality, die cast construction main jet wrenches have a rubber snap-off lid on body for storage of extra jets. Sold each.

### Description

6mm Round  
8mm Hex  
6mm Hex

### Order No.

[950-417](#)  
[950-416](#)  
[950-415](#)

## Keihin/Mikuni Main Jet Wrench

### Description

Main Jet Wrench

### Order No.

[002-401](#)



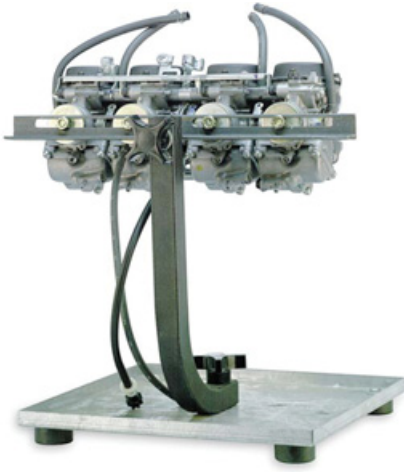

## K&L Carb Service Stand

This stand conveniently positions carburetors at an ideal height and allows 360° rotation for easy access. Parts storage base can be bench mounted. Ideal for multi carburetors. Included expansion plugs hold carbs with openings from 22mm to 41mm I.D. for unobstructed use.

Order No. **950-201**



## Motion Pro Float Bowl Wrench

Made from lightweight 6061 T-6 aluminum. This wrench is designed to remove the 17mm float bowl drain plugs. 12 point hex and low profile design for tight access. Sold each.

Order No. **950-737**



## HSR Easy Tool Kit

The Easy Tool Kit includes an Easy Wrench with 17mm x 11/16" open end wrench, Mini-T Jet Wrench with Phillips & Flat head blades and a 2.5mm Ball End Allen bit with 6mm hex. Mikuni No. KHS-033.

Order No. **002-046**



## Sudco Mikuni Carb Tool Kit

This handy little kit includes a multi-purpose wrench with ruler markings and a screwdriver with assorted blades and sockets. Sold as a set.

Order No. **002-045**



## Keihin FCR Tools

These tools allow access to allen screws from awkward angles which are not possible with traditional hex keys. Sold each.

### Description

3mm Ball Hex Driver  
4mm Ball Hex Driver

### Order No.

**950-210**  
**950-211**



## Magnetic Parts Dish

All-purpose magnetic dish is ideal for keeping track of loose fasteners and other small parts. Attaches magnetically to any steel surface. Measures 5 in. in diameter and is 1in. deep.

Order No. **950-776**

# Carburetor Tools



## Motion Pro Fuel Line Fittings Kit

This Fuel Line Fittings Kit contains a wide selection of Y and T fittings, hose clamps, o-clips and O-clip Pincher tool in an ABS plastic case. Ideal for the shop mechanic. Individual replacement parts are available to replenish the kit.

Order No. [950-462](#)



## Hose Shears

Scissor-action cutter, fast cutting of thin wall and small diameter PVC or Tygon type tubing, replaceable, teflon-coated tool steel blades, blades can be re-sharpened.

Order No. [950-773](#)



## Steel O-Clip Pincer Tool

Used to install and remove O-clips, PVC coated grip.

Order No. [950-774](#)



## Quick Disconnect Inline Fuel Couplers

For quick disconnections between tanks, pumps, filter and carbs. Two types available, single straight-thru and shut-off.

Description	Order No.
Straight-Thru, no-shut-off with 5/16" fuel line fitting	<a href="#">009-170</a>
Shut-off with 5/16" fuel line fitting	<a href="#">009-171</a>



## Coolant Recovery System

Prevents loss of coolant due to overheating, works on most off-road water-cooled motorcycles, snowmobiles and ATVs, designed for hot weather and/or high-altitude riding conditions, mounts to frame or behind number plate, includes 8 oz. bottle, hoses, clamps, mounting strap and instructions.

Order No. [950-778](#)



[009-102](#)

[009-100](#)

## Brass T-Fittings *Sold each*

Description	Order No.
1/4" Brass Fuel T	<a href="#">009-100</a>
3/8" Brass Fuel T	<a href="#">009-102</a>
.17" Brass Fuel T	<a href="#">009-101</a>



## K&N Fuel Line "T" *Sold each*

High flow, durable, lightweight, easy to use. One size fits 1/4" to 3/8" I.D. hose. Color: Black, Height: 0.999 in (25 mm), Length: 1.575 in (40 mm), Material Used: Plastic

Order No. [81-0270](#)





### Sudco Mikuni Tuning Manual

This 92 page manual includes exploded parts views, parts listings and optional parts. Guides you through tuning and trouble shooting for the popular lines of Mikuni Carburetors. The definite reference for Mikuni Carburetors and a must for any do-it-yourself type. Sold each.

Order No. **002-999**



### Motion Pro Battery Booster Cable Set

5 feet length, conveniently sized for motorcycle - motorcycle jump starting. Heavy-duty alligator clips are color-coded red and black. Conductor wire is firmly soldered to clamp for durability and reliability. Sold each.

Order No. **950-745**



### Mikuni Pocket Tuner

A handy pocket-size calculator which can be used to determine required jetting changes in Mikuni carburetors due to climate and temperature changes. The Pocket Tuner is applicable to both single and multi-carburetor applications on two-stroke and four-stroke engines. It also has a guide for determining rich or lean carburetor conditions.

Order No. **002-430**



### Motion Pro Cable Luber

Use to inject lubricant into cable housing. Clamps over cable housing allowing an aerosol can tip to be connected for injection inside. Once the lubricant runs out of far end, the cable is lubricated. Sold each.

Order No. **950-447**

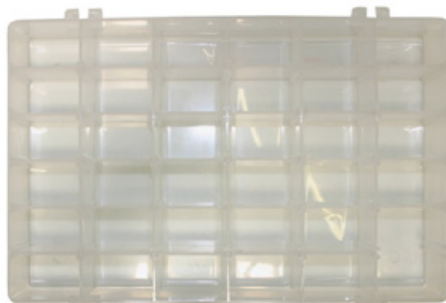

008-001



008-002

### Sudco Plastic Jet Boxes (Storage Boxes)

Two boxes available, 36 compartment and 18 compartment. Use for valve shim storage, small parts, electrical connectors and carburetor jets. Sold each.

Description	Order No.
Jet Box with 36 Compartments 7-1/2" L x 10-1/2" L x 1-1/4" H	<b>008-001</b>
Jet Box with 18 Compartments 3-1/4" L x 6-3/4" L x 1-1/2" H	<b>008-002</b>

# Wrenches & Pliers



## Motion Pro Clutch Holding Tool

Made from medium carbon steel with hardened jaws. Features 8mm spanner pins. Jaws open up to 5" wide. Hold clutch hubs, flywheels, gears, sprockets, etc. Recommended for square tooth style clutch hubs. **NOT RECOMMENDED** for v-groove or half round style clutch hubs. Sold each.

Order No. [950-728](#)



## 7 Way Crimping Tool (CT-1)

- Incorporates wire cutter, terminal crimper and wire stripper into one handy tool
- Black anodized finish with insulated hand grips
- Crimp slot on end of tool secures most ignition terminals including "W" type, right angle and "High-Tower" terminals
- Crimps 7mm to 8.5mm ignition wire
- Works with 10 to 22 gauge solderless terminals
- **WARNING** - Disconnect power source before using this tool.

Order No. [618-999](#)



## Motion Pro Yamaha ATV Axle Wrench

Made from heat-treated steel. Includes a 1/2" drive slot for use with a torque wrench or breaker bar. Sold as a set.

Order No. [950-464](#)



## Motion Pro Torque Wrench Adapter

Made from chrome vanadium tool steel with hard nickel pewter finish. Properly torque two-stroke cylinder base nuts and hard to reach fasteners. Multiply your torque wrench readings by chart supplied with tool for proper torque specifications. Always check with your owners manual for proper torque specifications for each model.

Order No. [950-460](#)



## Motion Pro Honda ATC Axle Nut Wrench

Heat treated steel. 27mm hex on one end and 42mm hex on other end. Fits most Honda ATC models. Sold each.

Order No. [950-419](#)





### Motion Pro 7 PC. Metric T-Handles

Durable nickel pewter finish. Includes 8mm, 10mm, 12mm, 14mm, 17mm and 19mm T-Handles with deep 6-point sockets. Includes a vinyl storage pouch. Sold as a set. (08-0113)

Order No. [950-730](#)

# T-Handle Wrenches



### Motion Pro 6 PC. Racer T-Handles Set

Durable nickel pewter finish. Includes 8mm, 10mm, 12mm, 14mm, T-Handles with deep 6-point sockets and No. 2 & No. 3 T-Handle Phillips screwdrivers.. Includes a vinyl storage pouch. Sold as a set. (08-0145)

Order No. [950-732](#)



### Motion Pro 5 PC. Mini-Pro T-Handles

Durable hard nickel pewter finish with Chrome-vanadium tool steel shafts. Includes 8mm, 10mm, 12mm, 13mm and 14mm, T-Handles with deep 6-point sockets. Sold as a set. (08-0340)

Order No. [950-734](#)



### Motion Pro T-Handle Phillips Set

Kit includes no 1, 2, and 3 Phillips t-handles, heat treated chrome-moly steel shaft and handle, up to 150 percent stronger than regular chrome-vanadium shafts used by other makers, durable chrome finish Limited lifetime warranty. Sold as a set. (08-0528)

Order No. [950-733](#)



### Motion Pro 11-Slot T-Handle Rack

Chrome finish, one piece design with 11 slot rack. Easily hangs on side of most tool boxes. Keeps T-Handles accessible and ready for use. Sold each. (08-0114)

Order No. [950-731](#)



### Motion Pro Timing Plug Wrench

Three different blade sizes. Fits straight-slot timing cover plugs on most motorcycles and ATV's. Blade sizes are 16mm (5/8"), 22mm (7/8") and 38mm (1-1/2"). Sold each.

Order No. [950-444](#)

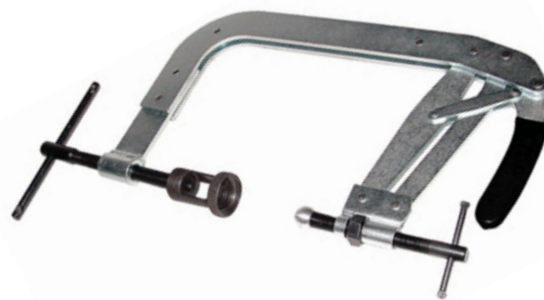

## Motion Pro 4-Stroke Leakdown Tester

Checks percentage of cylinder leakage in a 4-stroke engine. Tester includes 10, 12, and 14mm spark plug adapters, regulator and gauge.

Order No. [950-401](#)

## Motion Pro Valve Spring Compressor

Improved quick action design, used in same applications as Honda tool 07757-0010000 and Kowa tool AKS-215-1010 OEM tools. Accepts Motion Pro adapters (08-0248) as well as Honda OEM adapters 07GME-KT70200, 07JME-KY20100, and 07959-KM30101. For use in shim under bucket and small diameter valve spring keeper applications, both cup-type and ball-type tips are included. Adapter on compressor is double stepped. The inner step diameter is 17mm - Outer step diameter is 21mm.

Order No. [950-772](#)



## Motion Pro 2-Stroke Leakdown Tester

Designed to check for air leaks in 2-stroke engine. Tester includes air pressure gauge, pump-up bulb and most fittings and adapters for single and twin cylinder 2-stroke motorcycle engines. Packed in a convenient carry box, complete with instructions.

Order No. [950-400](#)

## Motion Pro Stud Installation Tools

These hex head stud tools allow installation of cylinder studs on most motorcycle applications without damaging the threads. Hex head is 3/4" or 19mm. Sold each. Order by size needed.

**Made in the USA.**

Description	Order No.
6 x 1.0mm	<a href="#">950-456</a>
8 x 1.25mm	<a href="#">950-457</a>
10 x 1.25mm	<a href="#">950-458</a>



## Motion Pro Crankcase Splitter

Works on most 2 & 4-stroke motorcycle engines with vertical split cases. Unique design eliminates binding under heavy loads. Movable fingers allow a multitude of bolt patterns to be used. Includes 6mm & 8mm mounting bolts.

Order No. [950-479](#)

## Motion Pro Spring Hooks (Pullers)

Use to remove exhaust pipe springs, seat or tank holding springs, cotter pins, side stand springs and other parts. Sold each.

Description	Order No.
Standard Spring Tool	<a href="#">950-725</a>
Heavy Duty T-Handle Spring Hook	<a href="#">950-726</a>



## Motion Pro Degree Wheel

Manufactured from .052" thick aluminum with a 6-3/4" outside diameter and a 6mm center hole. Black anodized finish with easy to read numbers. Check or set timing or cam timing. Use with 2 & 4-stroke engines. Sold each.

Order No. **950-442**



## Motion Pro Tappet Tool Set

Set contains three socket wrenches in 8mm, 9mm, 10mm and three adjusters, screw type, 3mm square and 4mm square. Fits nearly all models of Honda, Suzuki, and Yamaha Motorcycles and ATV's with screw-type adjusters.

Order No. **950-440**



## Motion Pro DELUXE Piston Pin Puller Tool

Interchangeable piston adapters, Made of durable 6061 aluminum Fits all piston pins from 12 mm (1/2 inch) to 24 mm (1 inch), Works on both full skirt and short skirt (slipper) pistons, Non marring aluminum pin adapters Durable blue anodized finish with laser engraved logo. **Made in the U.S.A.** Sold each.

Order No. **950-445**



## Motion Pro Valve Shim Tools

A must when setting valves with shim type adjustment. Available for the following models:

Description	Order No.
Honda CB750/900/CBX1000	<b>950-436</b>
Kawasaki KZ750 twin, KZ900/1000/1100/1300	<b>950-437</b>
Suzuki GS550/750/850/1100	<b>950-435</b>
Yamaha XJ600 Seca II	<b>950-435</b>
Yamaha XJ550/XJ650/XJ750	<b>950-438</b>
Yamaha XS750/XS850/XS1100	<b>950-438</b>



## APE Positive Stop TDC Tools

The only accurate way to find TDC (top dead center). Available in the following sizes:

Description	Order No.
10mm TDC Tool	<b>950-235</b>
12mm TDC Tool	<b>950-236</b>
14mm TDC Tool	<b>950-237</b>



## Motion Pro Valve Clearance Gauges

Sold in Card of six.

Assortment 2 each of the following sizes:

.002" - .003" (.05mm - .08mm), .004" - .005" (.10mm - .13mm)  
.006" - .008" (.15mm - .20mm).

Order No. **950-389**

# Brake & Wheel Tools



## Motion Pro Hydraulic Brake Bleeder

Makes bleeding your brakes a one-person job. The unique check valve allows brake fluid and air to escape while preventing air from re-entering the system. Instructions and hose included.

Made in the U.S.A.

Order No. [950-452](#)



## Mityvac Brake Bleeding Kit

Flushes out brake fluid quickly and cleanly into reservoir container. Kit includes a repairable pump, reservoir bottle with transfer and storage lids, bleeding adapters, plastic tubing and complete instructions.

Order No. [850-060](#)



## Motion Pro Master Cylinder Snap-Ring Pliers

Allows removal of internal snap rings used in hydraulic master cylinders. Replaces Honda# 07914-SA50001, can be used to remove and replace small to medium internal snap rings up to 50mm deep, including those used for transmission gear locating, bearing retention, and oil seal retention, applicable to some fork seal retaining rings.

Order No. [950-775](#)



## Motion Pro Chrome-Moly Hex Axle Tool

Heavy-duty heat treated 4130 chrome-moly construction, 3/8" square drive drivers are rated for a maximum of 150 ft.- lbs.

Order No. [950-758](#)



## Motion Pro Mini Brake Bleeder **NEW**

Mini Brake Bleeders combine wrench and bleeder valve into one convenient tool. Internal check valve and seal for easy bleeding. Simple to use design makes bleeding job faster. Three nipple sizes available.

Mini Brake Bleeder 8mm [950-453](#)

Mini Brake Bleeder 10mm [950-454](#)

Mini Brake Bleeder 11mm [950-455](#)





950-475



950-476

## Motion Pro Seal/Bearing Retainer Tools

Designed to remove & install the rear wheel seal/bearing retainer ring on Honda CR's and XR's. Precision design prevents damage to the retainer ring after peened "stakes" have been removed by drilling. Versatile design features a 22mm external hex head and 3/8" square drive. Order per application required. Sold each.

### 44mm CR Seal/Bearing Retainer Tool

For use on Honda CR125/250R 84-86, 89-99 and CR500R 84-86, 89-01. Honda OEM Reference 41231-KZ4-000

Order No. [950-476](#)

### 47mm CR/XR Seal/Bearing Retainer Tool

For use on Honda XR250R 84-91, XR350R 83-85, XR500R 81-84, XL600R 83-87, XR600R 85-00 and XR650L 93-00. Honda OEM Reference 41231-429-000 and 41231-286-000.

Order No. [950-475](#)



## Motion Pro Rotor and Sprocket Holder

Keeps flywheels, rotors and sprockets from rotating during removal and installation. Holds sprockets and rotors with holes center to center at a minimum distance of 13mm and a maximum distance of 230mm. Features 5 and 9mm pins. Adjustable stop-screw keeps tool open at set distance.

Order No. [950-756](#)



## Motion Pro Swingarm Bearing Tool

Designed for installation of the swingarm bearings on late-model Japanese motorcycles. Puller draws bearing into the swingarm and includes three drivers for use with common bearing sizes. Kit includes three drivers I.D. 20mm / O.D 26mm, I.D. 21mm / O.D. 26mm & I.D. 22mm / O.D.27mm.

Order No. [950-768](#)



## Motion Pro Wheel Bearing Remover Set

8 piece metric set includes large and small drivers, 10mm, 12mm, 15mm, 17mm, 20mm, and 25mm removers. Dependable split collet design, and metric sizes allow use with metric applications.

Order No. [950-757](#)

# Chain Tools



## Motion Pro Chain Breaker & Riveting Tool

This tool is versatile enough to be used on cam chains or drive chains. 2mm breaking tip for most cam chains, 3mm breaking tip for chains #25-#35 only, and 4mm breaking tip for drive chain #428-#630, it is recommended to grind the rivet head. Each kit includes 3 pin sizes to fit most chains (2.2mm, 2.9mm, 3.8mm) and press plates. with plastic storage box and instructions.

Order No. **950-420**

### Replacement Parts

Description	Order No.
2mm Replacement Tip	<b>950-421</b>
3mm Replacement Tip	<b>950-422</b>
4mm Replacement Tip	<b>950-423</b>
Replacement Rivet Tip	<b>950-424</b>



## Motion Pro Master Link Clip Pliers

Designed to simplify installation and removal of clip-type master links, one tip is shorter and notched to be placed on the pin which allows the longer end to push the clip.

Order No. **950-759**

## Motion Pro Jumbo Chain Tool **NEW**

Designed to break roller chain up to 630. Fits all standard & O-ring chain sizes 520 to 630. Rivets chain up to 530 (not 630). Master link side plate press kit included to press on side plates on chains up to 530 (not 630). The extractor pin is precisely guided by a removable guide, ensuring long pin life. May be bolted to a work bench, supported in a vise or held by handle. Recommended for heavy-duty use For riveting hollow nose master links. Requires 08-0142 Quad Stake Rivet Kit (not included) to rivet soft-nose type master link pin tip

Order No. **950-786**



## Motion Pro Chain Breaker

For chain #420 to #530 chain. This chain breaker pushes link pin completely through link/side plate. Handle folds away for easy storage. Sold each.

Order No. **950-430**

Replacement Pin - Heat treated for strength.

Order No. **950-431**



## Motion Pro PBR Chain Tool **NEW**

Innovative design will Press, Break & Rivet 520, 525, & 530 chains with one convenient tool. Removes chain pins, press master-link plates and rivet hollow nose & soft nose (quad stake) master link pins on O-ring and non O-ring type chains. Easy to use design allows you to change tool functions by simply moving the position of the anvil block. Indexing letters on movable anvil and body ensures correct tool configuration. All steel construction with heat treated components for strength and durability. Compact and light enough to carry in a tool bag for trail side repairs. Includes spare pin. Patented Design

Order No. **950-785**





## Rim Protectors

Protects your wheel from scratches and dings caused by tire changing tools. Retrieval cords are included for easy use

Order No. [950-752](#)



## Spoon Tire Iron

Curved end fits securely in the hand. Hard nickle pewter finish 10" long and weighs 4.2oz. Sold each.

Order No. [950-746](#)



## Bead Popper™

Designed for breaking the bead on road and off-road motorcycle tires, great for the shop, trail or on the road, Compact and lightweight (only 3.7 oz) stores easily in your emergency tool pack or tool box, can be used with the wheel on or off the motorcycle, will not scratch the wheel, easier and more convenient than press or lever tools, made of a durable, high-impact plastic, Not for use on ATV tires

Order No. [950-751](#)



[950-748](#)

[950-749](#)

[950-750](#)

## Standard Steel Tire Irons

Cold forged steel. Ideal for shop or home use. Tire Iron Set Includes one 8-1/2 inch tire iron, one 11 inch tire iron and one 16 inch double compound curved tire iron, and a vinyl storage pouch. Tire irons available separately. (each)

Description	Order No.
Tire Iron Set	<a href="#">950-747</a>
8-1/2" Tire Iron (each)	<a href="#">950-748</a>
11" Tire Iron (each)	<a href="#">950-749</a>
16" Tire Iron (each)	<a href="#">950-750</a>



## BeadPro Tire Bead Breaker and Lever Tool Set

Innovative multi-use tire tool set. Breaks the bead on most street and off road motorcycle tires. Integrated tire spoons for tire removal and installation. Light weight and compact size is perfect for tool packs. Ergonomic handles with crossguard keep hand from riding forward. Forged 7075-T6 aluminum construction for strength and durability Black anodized finish. Patent pending.

Order No. [950-788](#)



[950-755](#)

[950-754](#)

[950-753](#)

## Spoke Wrenches

Chrome-vanadium tool steel with a hard nickel pewter finish, square-end openings which grip the spoke nipple on all four sides, offset slotted ends make it easy and quick to use. Sold each.

Description	Order No.
6mm/6.3mm	<a href="#">950-753</a>
6.5mm/6.8mm	<a href="#">950-754</a>
5mm/7mm	<a href="#">950-755</a>

# Suspension Tools



## Motion Pro Combination Fork Damper Tool

Designed to hold the damper rod during assembly & disassembly of Honda XR400's or Suzuki DR-Z400S. One end features spanner-type prongs for the XR400 and the other a 27mm hex for Suzuki. Hardened steel with black finish.

Order No. [950-473](#)



## Motion Pro Damper Rod Fork Tool

Aids in assembly and disassembly of most inverted Kayaba and Showa 41mm, 43mm, 46mm, and 47mm forks. Use one end for Kayaba forks and the other for Showa forks. (not required for 91-92 Honda CR models) Hardened steel with black finish.

Order No. [950-474](#)



## Motion Pro Fork Seal Drivers

Manufactured from CAD-II plated carbon steel and features a split design. Each driver weighs approximately 25oz.

Sold individually. (split as shown in photo) **Made in U.S.A.**

Size	Order No.
39mm	<a href="#">950-392</a>
41mm	<a href="#">950-393</a>
43mm	<a href="#">950-394</a>
45mm	<a href="#">950-395</a>
46/47mm combo	<a href="#">950-396</a>
48mm <b>New!!</b>	<a href="#">950-769</a>
49/50mm combo	<a href="#">950-397</a>



## Fork Oil Level Gauge

For checking and adjusting the oil level on all conventional and single chamber cartridge forks, adjustable ring will measure oil levels from 0 to 300mm in 0.5cm increments, syringe has a capacity of 60ml, can be used on bicycles equipped with front suspension, also replaces HD tool HD-590000-B and Buell tool B-590000-B

Order No. [950-770](#)



## Seal Mate

Easy way to keep your fork seals clean and debris free. Extract dirt and debris trapped between fork seal and tube. Works on most conventional and up-side-down forks.

Order No. [950-399](#)



## Deluxe Suspension Bearing Service Tool **NEW**

Designed for quick and easy removal and precise installation of suspension linkage and swing arm pivot bearings. For use on 20 & 22 mm id bearings. Fits most off-road motorcycles & ATV's. Includes blind bearing collet for removal of 20 mm blind bearings. Anodized aluminum mandrels reduce the possibility of damaging bearing surfaces. Laser etched markings for easy size identification. Eliminates the need for a shop press. Includes protective blow-molded case for easy storage. A must have time saving tool for professional technicians, serious racers and home mechanics.

Order No. [950-787](#)



## Motion Pro Flywheel Pullers

Sold each. Order by size needed or per applications listed.

Description	Notes	Motion Pro Reference	Order No.
M16mm x 1.5mm R.H.	Solid Puller Bolt	08-0027	<b>950-467</b>
M18mm x 1.5mm R.H.	Solid Puller Bolt	08-0116	<b>950-468</b>
M18mm x 1.5mm R.H.	Solid Puller Bolt	08-0118	<b>950-470</b>
M20mm x 1.5mm R.H.	Solid Puller Bolt	08-0085	<b>950-471</b>
M20mm x 1.5mm R.H.	Hollow Puller Bolt	08-0086	<b>950-472</b>
M22mm x 1.5mm R.H.	Solid Puller Bolt	08-0074	<b>950-469</b>
27mm x 1.0mm L.H.	Puller Bolt with body	08-0026	<b>950-466</b>
M24mm x 1.5mm R.H.	Puller Bolt with body	08-0257	<b>950-767</b>
M26mm x 1.0mm R.H.	Puller Bolt with body	08-0293	<b>950-762</b>
M28mm x 1.0mm R.H.	Puller Bolt with body	08-0425	<b>950-739</b>
M28mm x 1.0mm R.H.	Puller Bolt with body	08-0372	<b>950-763</b>
M30mm x 1.0mm R.H.	Puller Bolt with body	08-0386	<b>950-766</b>
M33mm x 1.5mm R.H.	Puller Bolt with body	08-0390	<b>950-764</b>
M35mm x 1.5mm R.H.	Puller Bolt with body	08-0349	<b>950-765</b>
M38mm x 1.5mm R.H.	Puller Bolt with body	08-0306	<b>950-760</b>
M50mm x 1.5mm R.H.	Puller Bolt with body	08-0417	<b>950-767</b>
Disc with 6 bolts	w/handle & 6 Bolt Holes	08-0160	<b>950-761</b>



## Honda/Kawasaki/KTM/Suzuki/Yamaha 27mm x 1.0mm L.H.

Motion Pro Reference 08-0026. Sold each.

Order No. **950-466**

### Honda

CR80R/CR80RB, CR85R/CR85RB, CR125R, CR250R, CR500R 2-stroke, XL/XR50/70/100/185, CRF50F, ATC70, ATC185/ATC250R, TRX90 all

### Kawasaki

KX/KDX80/125/200/220/250/500 2-stroke and most external flywheel models, early point-type ignition

### KTM

65SX (99-04), 85SX (2004), 105SX (2004), 200EXC/MXC (98-05) 125/250SX/EXC/MXC (98-05), 250/300/380 SX/EXC/MXC (97-05)

### Suzuki

RM125 late model 1992 on (will not work on early model RM/TM), RM/RMX250 late model 1992 on, some DR series small bore

### Yamaha

YFS200 Blaster, YFZ350 Banshee, YSR50, YZ400F 4-stroke, YFM80/YFM100/YFM200/YFM225, YT125/YT175



## Honda/Kawasaki M20mm x 1.5mm R.H.

Hollow Puller Bolt. Motion Pro Reference 08-0086. Sold each.

Order No. **950-472**

### Honda

ATC250SX, ATC350X, TRX250/300/300FW, TRX300EX (93-05), TRX400EX (99-05), XR400R (96-04), CB400A/T (78-79), CM450, GL500/CX500, GL650/CX650, XR650R Offroad (00-07), PC800, VFR800 Interceptor



## Honda/Kawasaki M20mm x 1.5mm R.H.

Solid Puller Bolt. Motion Pro Reference 08-0085. Sold each.

Order No. **950-471**

### Honda

FT/GB500, NT650 Hawk GT, NX650 (88-89), TL250, VF700C (84-86), VF700F/S, VF750C (82-83), VF750F/S, VF1000F/R, VF1100C/S, VFR700/750F (1986), VT500C/FT, VT600C/CD (88-89) and (91-96), VT600C/CD/CD2 (97-02), VT750C/CD/CD2, XL250/350/500/600, XR500, XR600R Offroad (85-00), XR650L Dual Sport (93-09)

### Kawasaki

KL250 KLR (85-95), KL650A KLR (87-95)

### Suzuki

SV650 (99-05), SV650S (99-05), GSX-R600 (97-00) GSX-R750 (96-99), DL1000K V-Storm (02-05), SV1000K (02-05) SV1000S (03-05), TL1000R (98-04), TL1000S (97-01) GSX1300R Hayabusa (99-05)



## Honda/Kawasaki/Suzuki/Yamaha M16mm x 1.5mm R.H.

Motion Pro Reference 08-0027. Sold each.

Order No. **950-467**

### Honda

ATC90 all with point-type ignition, ATC110 with point-type ignition CB175, CB350G/CB360, CB500 twin, CM185/CM200 Twinstar, early CR125/CR250 Elsinore 2-stroke, SL175/SL350

### Kawasaki

KH400A 2-stroke triple, KLF300 Bayou (86-87), KLT110/KLT200, KX125/KX250/KX420/KX500 pre-1981 models, Z1-900 (73-75), KZ1000 (77-80)

### Suzuki

GS550/650/750 models with point-type ignition, early 1100 and most 4-stroke street models

### Yamaha

Most 4-stroke applications, XJ550/XJ650/XJ750 Maxim & Seca, FZ600/FJ600, FZR600, TT225



## Kawasaki Personal Watercraft M18mm x 1.5mm R.H.

Solid Puller Bolt. Allows you to pull flywheel without pulling motor from hull. Motion Pro Reference 08-0118. Sold each.

Order No. **950-470**

### Kawasaki

JH750A/E (92-96), JH750B/F (93-96), JH750C (95-96), JS750A (92-95), JS750B (95-96), JT750A (94-95), JT750B (95-96)

# Flywheel Pullers



## Honda M28mm x 1.0mm R.H. Internal Thread

Includes 12mm crankshaft protector cap. Replaces Honda OEM part numbers 070MC-HP10100 puller and 070MC-HP1A100 crankshaft protector cap. Motion Pro Reference 08-0425. Sold each.

Order No. [950-739](#)

### Honda

CRF450X (04-07) and TRX450R/ER (06-07)



## Suzuki M50mm x 1.5mm R.H. Internal Thread

Includes crankshaft protector M16mm x P1.5mm. Motion Pro ref. 08-0417.

Order No. [950-767](#)

### Suzuki

LS650 Savage (87-07), VS1400 (87-07), GV1400 (86-87), VX800 (90-93), VS700 (1986), VS750 (88-91), VZR1800 (06-07), VL1500 (98-07), VS800 (92-95)

#### ATV

LT-A500F (00-07), LT-F500F (98-07), LTA-700X (05-07), LTA-450X (2007), LT-F400F (02-07), LTA-400F (02-07), LT-F400 (02-04), LT-A400 (02-04) and (2006)



## Kawasaki/Yamaha M35 x 1.5mm R.H. Internal Thread

Motion Pro Reference 08-0349.

Order No. [950-765](#)

### Kawasaki

EX250E Ninja 250R (86-87), EX250F Ninja 250R (88-09)

### Yamaha ATV

YFM350 (1997), YFM350ER (89-95), YFM350FAH (2004), YFM350FW (89-99), YFM350FX (95-96), YFM350S/RT (04-05), YFM350U (96-99), YFM350X (89-03), YFM350AS (04-05), YFM350FX (97-03), YFM350FXS (04-05), YFM350XS (04-05), YFM400A (00-02), YFM400F (96-99), YFM400FA (02-04), YFM400FAHS (04-05), YFM400FAT (2005), YFM400FM (2000), YFM400FS (04-05), YFM400FT (2005), YFM400FW (99-03), YFM400N (00-03), YFM400P (2001), YFM400S (04-05), YFM660F (02-06), YFM 700R (2006)



## Honda/Kawasaki M22mm x 1.5mm R.H.

Solid Puller Bolt. Motion Pro Reference 08-0074. Sold each.

Order No. [950-469](#)

### Honda

VT600 Shadow VLX, VFR700/VFR750, XR500/XR600R/XR650L, VF700/VF750/VF1000F/VF1000R, VF1100C/S.

### Kawasaki

KL600A/B KLR (84-86), KL650A KLR (96-06).



## Kawasaki M18mm x 1.5mm R.H.

Solid Puller Bolt. Motion Pro Reference 08-0116. Sold each.

Order No. [950-468](#)

### Kawasaki

KLF110, KSF250 Mojave (96-00), KZ200/KZ250 all, EX250 Ninja all, KL250, KZ400/KZ440 all, EN500 all, EX500 all, KZ550/GPz550, ZX600 Ninja 600R, KZ650 78-83, ZX750 GPz, KZ750 4-cyl. all, KZ900, KZ1000, KZ1100, GPz1100, KZ1300



## Honda M24mm x 1.5mm R.H. Internal Thread

Includes 12mm crankshaft protector cap. Replaces Honda OEM part numbers 070MC-MEBA100 puller, Kawasaki 57001-1565 and Suzuki K57001-11565-LPT. Motion Pro Reference 08-0257. Sold each.

Order No. [950-740](#)

### Honda

CRF150R (07-08), CRF250R/CRF250X (03-07), CRF450R (02-07)

### Kawasaki

KX250F (04-07), KX450F (06-07)

### Suzuki

RM-Z250 (04-06), RM-Z450 (05-06)

### Yamaha

YZ450F (06-07)



## Arctic Cat/Kawasaki/Suzuki M38mm x 1.5 R.H

Replaces OEM Suzuki tool 09930-31921-LPT. Motion Pro Ref.08-0306.

Order No. **950-760**

### Arctic Cat

DVX400 (04-07)

### Kawasaki

KLX400 Offroad (2003), KSF400 ATV (03-06)

### Suzuki

AN400K Burgman Scooter (03-07), DR-Z250 Offroad (01-07), LT-Z90 Quad Sport (07-09), LT-Z250 Quad Sport (04-09), LT-F300F (99-01), DR-Z400 Offroad (01-06), DR-Z400E Offroad (00-07), DR-Z400S Dual Sport (00-09) and (11-12), DR-Z400SM Supermotard (05-09), LT-Z400 Quad Sport (03-09), LT-R450 Quad Racer (06-08)



## Honda/Kawasaki/Suzuki M28mm x 1.0mm R.H. Internal Thread

Replaces OEM Honda tool 070MC-HP1A100. Includes M14x1.25 shaft protector cap, OEM tool 070MC-HP1A110. Motion Pro Reference 08-0372.

Order No. **950-763**

### Honda

TRX450R (04-05), CR250R (78-80)

### Kawasaki

KLX110 (03-07), Suzuki DRZ110 (03-05)



## Suzuki/Yamaha M33mm x 1.5mm R.H. Internal Thread

All steel construction, durable black oxide finish. Motion Pro Ref.08-0390.

Order No. **950-764**

### Suzuki

GSX-R600 (01-05), GSX-R750 (01-05), GSX-R1000 (01-05)

### Yamaha

YFZ450 ATV (04-07), WR 450F (04-06)



## KTM M26mm x 1.0mm R.H. Internal Thread

Replaces OEM tool 580.12.009.000. Includes 12mm shaft protector cap OE reference 510.12.016.000. Not applicable on older models with Motoplat ignition systems. Motion Pro Reference 08-0293.

Order No. **950-762**

### KTM

250 RFS, 250SX-F, 400, 450, 520, 525, 250, 300 two stroke with electric start



## Yamaha/Kawasaki Flywheel Puller

Use for removal of magneto flywheel or starter gear on Kawasaki Jet Ski's. Includes three 6 x 25 mm and three 8 x 40 mm bolts. 8 mm bolt hole center is 27 mm to dead center and 6 mm bolt hole center is 49.15 mm to dead center. Also used for Yamaha models listed. Motion Pro Reference 08-0160.

Order No. **950-761**

### Kawasaki

Jet Ski - JS300/440/550

### Yamaha

WR250F Offroad (01-02) and WR400F Offroad



## Yamaha M30mm x 1.0mm R.H. Internal Thread

Replaces OEM Yamaha tool YM-04141. Motion Pro Reference 08-0386.

Order No. **950-766**

### Yamaha

WR250F (03-06)

# KEIHIN CDKII Exploded View

## Keihin CDKII

## Keihin CDKII w/ Accelerator Pump

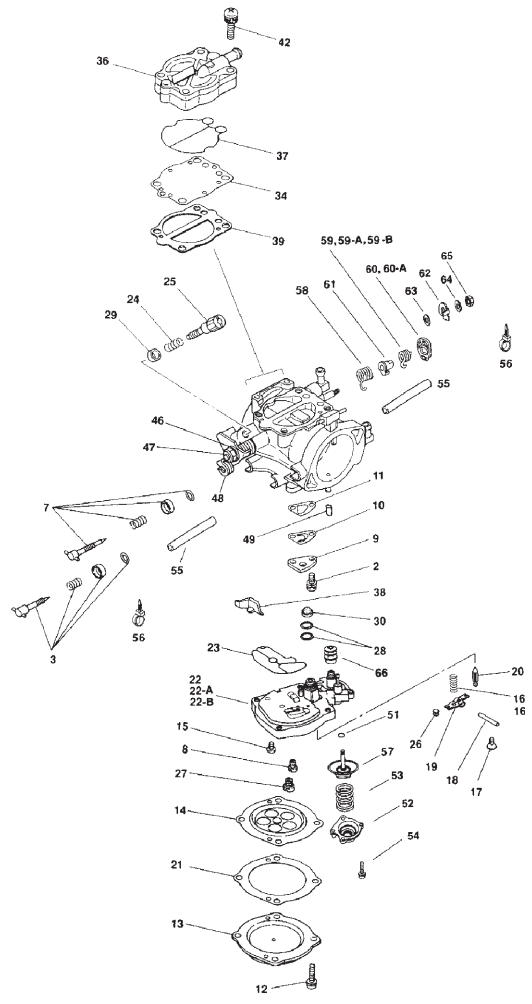
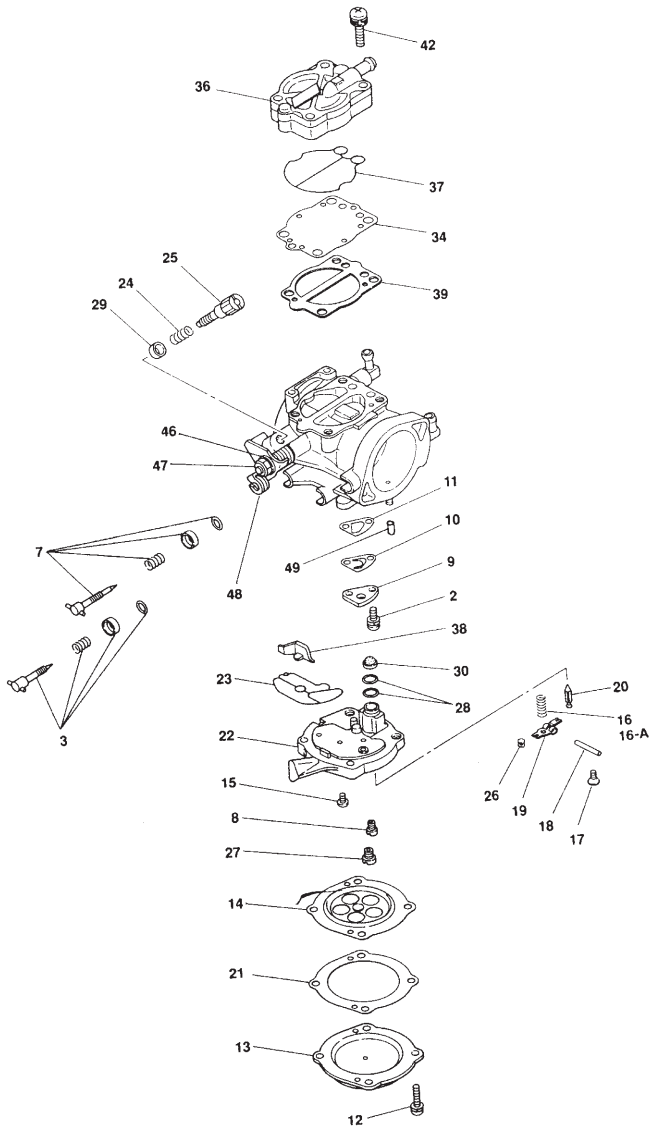

**NOTE:** Do not remove parts that are not shown on this exploded view.

**Note: This exploded view is CDKII 42. NEVER try to remove parts which are not shown in this view.**

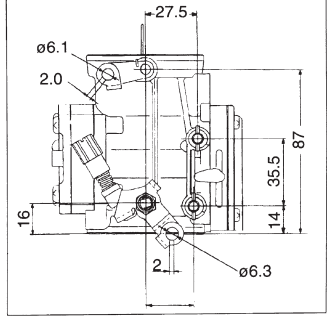
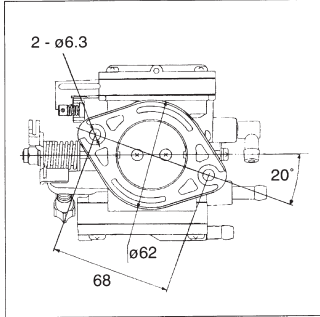
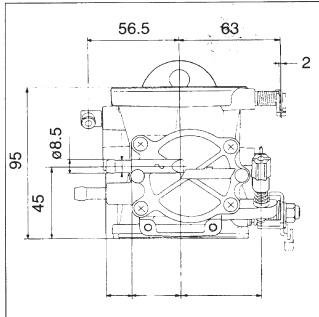
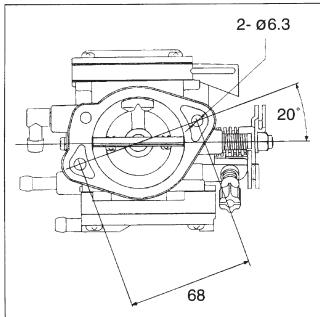

## Keihin CDKII

## Keihin CDKII w/ Accelerator Pump

No.	Description	Keihin No.	Order No	Keihin No.	Order No
2.	Screw	N114-03060	<b>021-463</b>	N114-03060	<b>021-463</b>
3.	Adjust Screw (Main)	Z014-0660	<b>021-461</b>	Z014-0660	<b>021-461</b>
7.	Adjust Screw (Slow)	Z014-0670	<b>021-462</b>	Z014-0670	<b>021-462</b>
8.	Slow Jet	N424-35-□□□	<b>Pg.514</b>	N424-35-□□□	<b>Pg.514</b>
9.	Plate	1090-823-2000	---	1090-823-2000	---
10.	Check Valve*	1242-809-2000*	---	1242-809-2000*	---
11.	Gasket*	1202-823-2000*	<b>021-466</b>	1202-823-2000*	<b>021-466</b>
12.	Screw	0135-828-1900	<b>021-467</b>	0135-828-1900	<b>021-467</b>
13.	Cover	1230-827-2000	---	1230-827-2000	---
14.	Diaphragm*	1201-813-2100*	<b>021-469</b>	1201-813-2100*	<b>021-469</b>
15.	Screw	93500-04008-1H	<b>021-053</b>	93500-04008-1H	<b>021-053</b>
16.	Coil Spring(70g)*	1290-947-2000*	<b>021-450</b>	1290-961-2000*	<b>021-471</b>
16A.	Coil Spring (40g)	1290-966-2000	<b>021-451</b>	1290-992-2000	<b>021-472</b>
17.	Screw	4114-001-1200	---	4114-001-1200	---
18.	Arm Pin	16152-KG8-9010-M1	---	16152-KG8-9010-M1	---
19.	Float Arm	1054-823-2000	<b>021-475</b>	1054-823-2000	<b>021-475</b>
20.	Needle Valve*	1062-818-2000	<b>018-679</b>	1062-818-2000	<b>018-679</b>
21.	Gasket*	1202-822-2000*	<b>021-476</b>	1202-822-2000*	<b>021-476</b>
22.	Jet Block 1.6 VS	1605-829-2101-1.6	---	1605-853-2101-1.6	---
22A.	Jet Block 1.8 VS	1605-829-2101-1.8	---	1605-853-2102-1.8	---
22B.	Jet Block 2.0 VS	1605-829-2101-2.0	---	1605-853-2102-2.0	<b>021-436</b>
23.	U-Ring*	0903-809-6000*	---	0903-809-6000*	---
24.	Coil Spring	1290-050-2000	---	---	---
25.	Stop Screw	1034-824-7000	---	---	---
26.	Lever Pin	1480-049-2004	<b>021-480</b>	---	---
27.	Main Jet	N424-36-□□□	<b>Pg.514</b>	---	---
28.	O-Ring	0901-055-6000*	---	---	---
29.	Collar	1118-935-7000	---	---	---
30.	Screen*	2009-811-2100	---	---	---
34.	Diaphragm*	1201-825-2000*	<b>021-470</b>	---	---
36.	Fuel Pump Comp.	1000-983-0400	---	---	---
37.	O-Ring*	0901-841-6000*	<b>021-488</b>	---	---
38.	Collar	1118-964-7000	---	---	---
39.	Gasket*	1202-851-2000*	<b>021-477</b>	---	---
42.	Screw	4129-826-1900	---	---	---
46.	Spring Washer	0303-801-1000	---	---	---
47.	Locknut	0208-807-1000	---	---	---
48A.	Thr. Lever A	1026-952-2000	<b>021-455</b>	---	---
48B.	Thr. Lever B	1026-949-2001	<b>021-456</b>	---	---
48C.	Thr. Lever C	1026-951-2000	<b>021-457</b>	1026-951-2000	<b>021-457</b>
48D.	Thr. Lever D	1026-950-2000	<b>021-458</b>	1026-950-2000	<b>021-458</b>
49.	Cap	1096-047-2001	---	1096-047-2001	---
50.	Screw	4110-812-1000	---	4110-812-1000	---
51.	U-Ring	N/A	---	W9353-40000	<b>021-495</b>
52.	Cover, Accp.	N/A	---	1230-845-2000	---
53.	Coil Spring, Accp	N/A	---	1290-987-2000	---
54.	Screw, Accp.	N/A	---	0135-823-1000	---
55.	Rubber Hose	N/A	---	0804-A81-0000	<b>021-205</b>
56.	Zip Tie	N/A	---	W3756-001-9900	---
57.	Diaphragm Comp, Accp.	N/A	---	1201-829-2102	---
58.	Coil Spring, Accp.	N/A	---	1305-A06-2000	<b>021-501</b>
59.	Coil Spring, Accp. Cam	N/A	---	1305-990-2000	<b>021-502</b>
59A.	Coil Spring, Accp. Cam	N/A	---	1305-991-2000(+80%)	<b>021-503</b>
60.	Accp. Cam	N/A	---	1100-886-7000	---
60A.	Accp. Cam	N/A	---	1100-889-7000	---
			---	(-20% volume)	---
61.	Collar	N/A	---	1118-A11-7000	---
62.	Plate	N/A	---	1026-986-2000	---
63.	Plain Washer	N/A	---	0301-862-1000	---
64.	Spring Washer	N/A	---	0303-801-1000	---
65.	Nut	N/A	---	0208-801-1000	<b>021-510</b>
66.	Boots	N/A	---	1028-054-7000	<b>021-511</b>

\* Included in rebuild kit **025-625**  
Order 1 per carb.

Note: This rebuild kit fits all CDKII 28 or OEM Kawasaki and after-market carbs. There may be extra parts in the kit depending upon the origin of your particular carburetor unit.

\* Included in rebuild kit **025-627**  
Order 1 per carb

Note: This rebuild kit fits all CDKII 38, 40, 42 carbs for OEM Kawasaki and aftermarket carbs. There may be extra parts in the kit depending upon the origin of your particular carburetor unit.

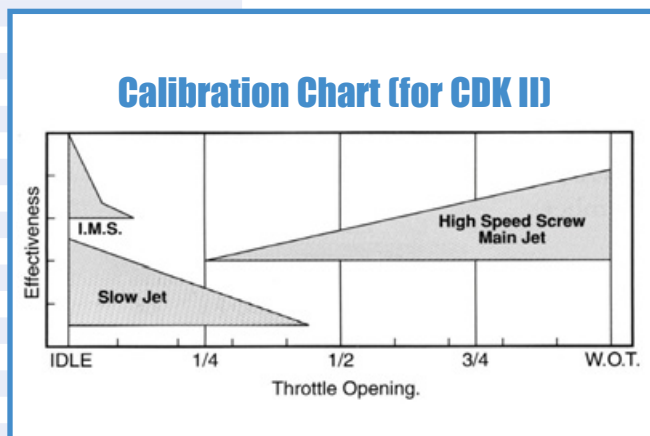

### Throttle Linkages

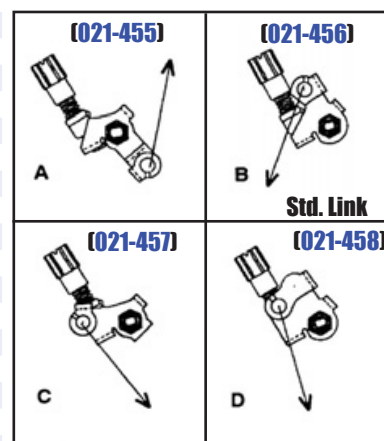

NOTE: The arrows show you throttle cable direction.



## CDK Carburetor Rebuild Kits

Includes all parts necessary to completely rebuild the Keihin CDK carburetors to factory specifications. **Made in Japan.**

Description	Order No.
CDK28mm	025-625
CDK38, 40, 42mm	025-627

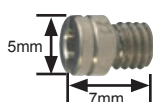

N424-35-xxx Slow Jet

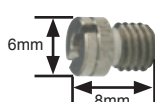

N424-36-xxx Main Jet

## N424-35-XXX Slow jets

Nickel plated slow jets to prevent corrosion.

**Applications:** CDK, CDKII 38 & 42 Watercraft Carburetors, Kawasaki OEM Jet-Ski with CDK carburetors.

Size	Order No.	Size	Order No.	Size	Order No.
#50	019-630	#75	019-640	#100	019-650
#52	019-631	#78	019-641	#102	019-651
#55	019-632	#80	019-642	#105	019-652
#58	019-633	#82	019-643	#108	019-653
#60	019-634	#85	019-644	#110	019-654
#62	019-635	#88	019-645	#112	019-655
#65	019-636	#90	019-646	#115	019-656
#68	019-637	#92	019-647	#118	019-657
#70	019-638	#95	019-648	#120	019-658
#72	019-639	#98	019-649		

## Fuel Pump Rebuild Kit

Includes all parts necessary to completely rebuild the Keihin Fuel Pump to factory specifications. Replaces internal parts (gaskets, diaphragms and check valves) on Kawasaki 49040-3706 Fuel Pump. **Made in Japan.** See model application listing below for Kawasaki Jet Ski Watercraft.

Order No. 020-310

## Kawasaki Personal Watercraft

Model	Year
JB650A1/A2 Jet Mate	89-90
JF650A1/A2/A3/A4/A5 X2	86-90
JF650B1/B2 Tandem Sport (TS)	89-90
JS650A1/A2/A3/A4 SX	87-90

## N424-36-XXX Main Jets

Nickel plated main jets to prevent corrosion.

**Applications:** Keihin CDK, CDKII 38 & 42 Watercraft Carburetors. OEM Kawasaki Jet-Ski with CDK carburetors.

Size	Order No.	Size	Order No.	Size	Order No.
#100	019-580	#132	019-593	#165	019-606
#102	019-581	#135	019-594	#168	019-607
#105	019-582	#138	019-595	#170	019-608
#108	019-583	#140	019-596	#172	019-609
#110	019-584	#142	019-597	#175	019-610
#112	019-585	#145	019-598	#180	019-612
#115	019-586	#148	019-599	#185	019-614
#118	019-587	#150	019-600	#190	019-615
#120	019-588	#152	019-601	#195	019-616
#122	019-589	#155	019-602	#200	019-617
#125	019-590	#158	019-603		
#128	019-591	#160	019-604		
#130	019-592	#162	019-605		

## Pop-Off Pressure Chart

Spring Force	Spring Length	Needle Valve Size (mm)		
		16(Std)	1.8	2.0
70gr(Std)	11mm	24psi	21psi	18psi
40gr.	9.7mm	15psi	13psi	11psi



## Choke Shaft Block-Off

CDKII choke plate block off.

Order No. 021-440



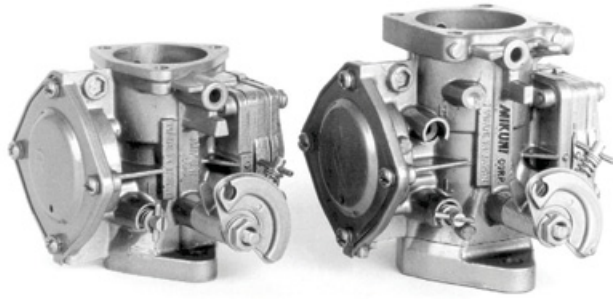

## Super BN Series Square Pump Type Carburetors

Super BN series carburetors feature improved air flow, higher capacity fuel pump, externally adjustable metering screws and replaceable fixed jets for easy high and low speed tuning. Special needle valves and springs give optimum pop-off pressure. **Made in Japan.**

**Performance 44mm single** BN44-40-8067 **001-096**

For most sit-down models requiring larger jets. Features a 2.5 viton tip needle valve, #120 pilot (slow) jet, #140 main (high) jet, primer fitting and owners manual. (No butterfly choke)

**Performance 38mm single** BN38-34-8113 **001-091**

Replaces most standard BN or Super BN carbs. Features a 2.0 viton tip needle valve, #65 pilot (slow) jet, #107.5 main (high) jet, primer fitting and owners manual. (No butterfly choke)

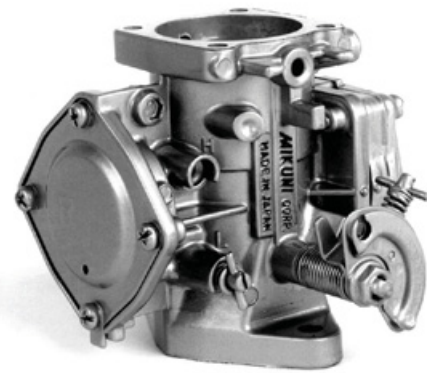

## Pro Racing Super BN46 Series Carburetor

Designed to give Pro Level Racing performance. Features a viton 2.5 needle valve, #120 pilot (slow) jet, #150 main (high) jet, primer type cold starter fitting, angled fuel fittings and owners manual. (No butterfly choke) **Made in Japan. Note: Bolt pattern is same as BN44, some porting may be necessary for maximum air flow.**

**Performance 46mm Single** BN46-42-8002 **001-099**



Photo courtesy of Pro-Tec



## Sudco Mikuni Tuning Manual

This 92 page manual includes exploded parts views, parts listings and optional parts. Guides you through tuning and trouble shooting for the popular lines of Mikuni Carburetors. The definite reference for Mikuni Carburetors and a must for any do-it-yourself type. Sold each.

Order No. **002-999**

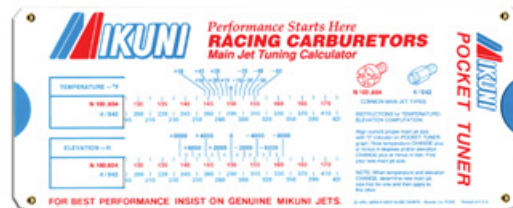

## Mikuni Pocket Tuner

A handy pocket-sized calculator which can be used to determine required jetting changes in Mikuni carburetors due to climate and temperature changes. The Pocket Tuner is applicable to both single and multi-carburetor applications on 2-stroke and 4-stroke engines. It also has a guide for determining lean or rich carburetor conditions.

Order No. **002-430**

# Mikuni Fuel Pumps & Rebuild Kits



DF44-211

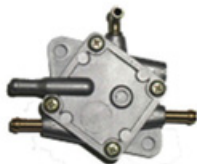

DF52-136



DF52-21



DF52-73



DF52-92



DF62-702

## Mikuni Pulse Fuel Pumps

Mikuni Pulse Fuel Pumps employ an engine's fluctuating engine crankcase pressure to pump fuel from a remote fuel tank to an engine's carburetor(s). Applications include Personal Watercraft and Snowmobiles. Sold each.

Mikuni No.	Number of Outlets	Style	Mounting	Flow Rate Liter/Hour	Order No. Fuel Pump	Order No. Rebuild Kit
DF44-211 (DF44-227)	1	Square	Flush	14	002-220	002-225
D52-21 (DF52-176)	2	Round	Bracket	35	002-221	002-223
DF52-73	2	Round	Flush	35	002-228	002-223
DF52-92	3	Round	Flush	35	002-229	002-223
DF52-136	2	Square	Flush	31	002-222	---
DF62-702	2	Pentagon	Flush	65	002-227	002-226



002-225



002-223

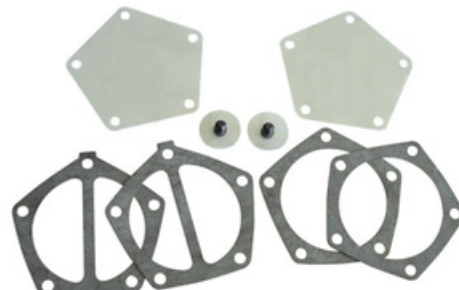

002-226

## Mikuni Fuel Pump Rebuild Kits

Sold in kits. See contents listing for parts in each kit.

**Mikuni Kit No. MK-DF44** Order No. **002-225**  
Fits DF44 Fuel Pump.

Contents	Description	Qt.	Remarks
CW2=0416	Screw	4	with lock washer
DF44-201/03	Gasket	1	Fiber
DF44-201/04	Diaphragm	1	Clear
DF44-201/05	Membrane	1	Thin Rubber

**Mikuni Kit No. MK-DF62** Order No. **002-226**  
Fits DF62 Fuel Pump

Contents	Description	Qt.	Remarks
DF62-601/03	Gasket	2	Paper Gasket
DF62-601/04	Diaphragm	2	Clear
DF62-701/03	Gasket	2	Paper Gasket
DF62-701/05	Check Valve	2	Clear Grommet

**Mikuni Kit No. MK-DF52** Order No. **002-223**  
Fits ALL DF52 Fuel Pumps except DF52-136.

Contents	Description	Qt.	Remarks
DF52-105	Gasket	1	Thick Fiber
DF52-48/10	Diaphragm	2	Transparent Film
DF52-48/05	Gasket	1	Thin Rubber
DF52/113	Gasket	1	Thin Rubber
DF52/36A	Gasket	1	Thick Fiber
DF52/27A	Valve	2	Clear
DF44/26	Grommet	2	Black

Note: Fuel Pump Rebuild Kit for DF52-136 is not available.

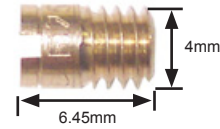
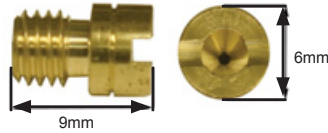

## High Speed Jets N102.221

**Applications:** Personal Watercraft (High Speed Jets)  
Super BN 38, BN44, BN46, BN38I, BN40I, BN44I, BN46I

Size	Order No.	Size	Order No.	Size	Order No.
#30	004-333	#92.5	004-282	#155	004-307
#32.5	004-334	#95	004-283	#157.5	004-308
#35	004-335	#97.5	004-284	#160	004-309
#37.5	004-336	#100	004-285	#162.5	004-310
#40	004-337	#102.5	004-286	#165	004-311
#42.5	004-338	#105	004-287	#167.5	004-312
#45	004-339	#107.5	004-288	#170	004-313
#47.5	004-340	#110	004-289	#172.5	004-314
#50	004-255	#112.5	004-290	#175	004-315
#52.5	004-256	#115	004-291	#177.5	004-316
#55	004-267	#117.5	004-292	#180	004-317
#57.5	004-268	#120	004-293	#182.5	004-318
#60	004-269	#122.5	004-294	#185	004-319
#62.5	004-270	#125	004-295	#187.5	004-320
#65	004-271	#127.5	004-296	#190	004-321
#67.5	004-272	#130	004-297	#195	004-323
#70	004-273	#132.5	004-298	#200	004-325
#72.5	004-274	#135	004-299	#205	004-326
#75	004-275	#137.5	004-300	#210	004-327
#77.5	004-276	#140	004-301	#215	004-328
#80	004-277	#142.5	004-302	#220	004-329
#82.5	004-278	#145	004-303	#230	004-330
#85	004-279	#147.5	004-304	#240	004-331
#87.5	004-280	#150	004-305		
#90	004-281	#152.5	004-306		

## Slow Speed Jets N100.606

**Applications:** Slow Speed Jet on BN Personal Watercraft Carburetors.  
Super BN 38, BN44, BN46, BN38I, BN40I, BN44I, BN46I

Size	Order No.	Size	Order No.	Size	Order No.
#30	004-442	#75	004-460	#120	004-478
#32.5	004-443	#77.5	004-461	#122.5	004-479
#35	004-444	#80	004-462	#125	004-480
#37.5	004-445	#82.5	004-463	#127.5	004-481
#40	004-446	#85	004-464	#130	004-482
#42.5	004-447	#87.5	004-465	#132.5	004-483
#45	004-448	#90	004-466	#135	004-484
#47.5	004-449	#92.5	004-467	#137.5	004-485
#50	004-450	#95	004-468	#140	004-486
#52.5	004-451	#97.5	004-469	#142.5	004-487
#55	004-452	#100	004-470	#145	004-488
#57.5	004-453	#102.5	004-471	#147.5	004-489
#60	004-454	#105	004-472	#150	004-490
#62.5	004-455	#107.5	004-473	#152.5	004-493
#65	004-456	#110	004-474	#155	004-491
#67.5	004-457	#112.5	004-475	#157.5	004-494
#70	004-458	#115	004-476	#160	004-492
#72.5	004-459	#117.5	004-477		

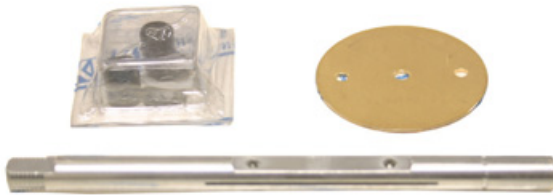

## Throttle Shaft Rebuild Kits

Kits include butterfly valve, shaft seals, screws and instructions.

Carb Size	Mikuni No.	Order No.
BN38	MK-BN038TV	007-335
BN44	MK-BN044TV	007-336
BN46	MK-BN046TV	007-337



## Sudco Primer Kit

Sudco's primer kit is made of brass and includes fuel line and plastic inline "T". Plunger type operation. *Made in the USA.*

Order No. 002-995

# IKUNI BN (Round Pump Carb Type)

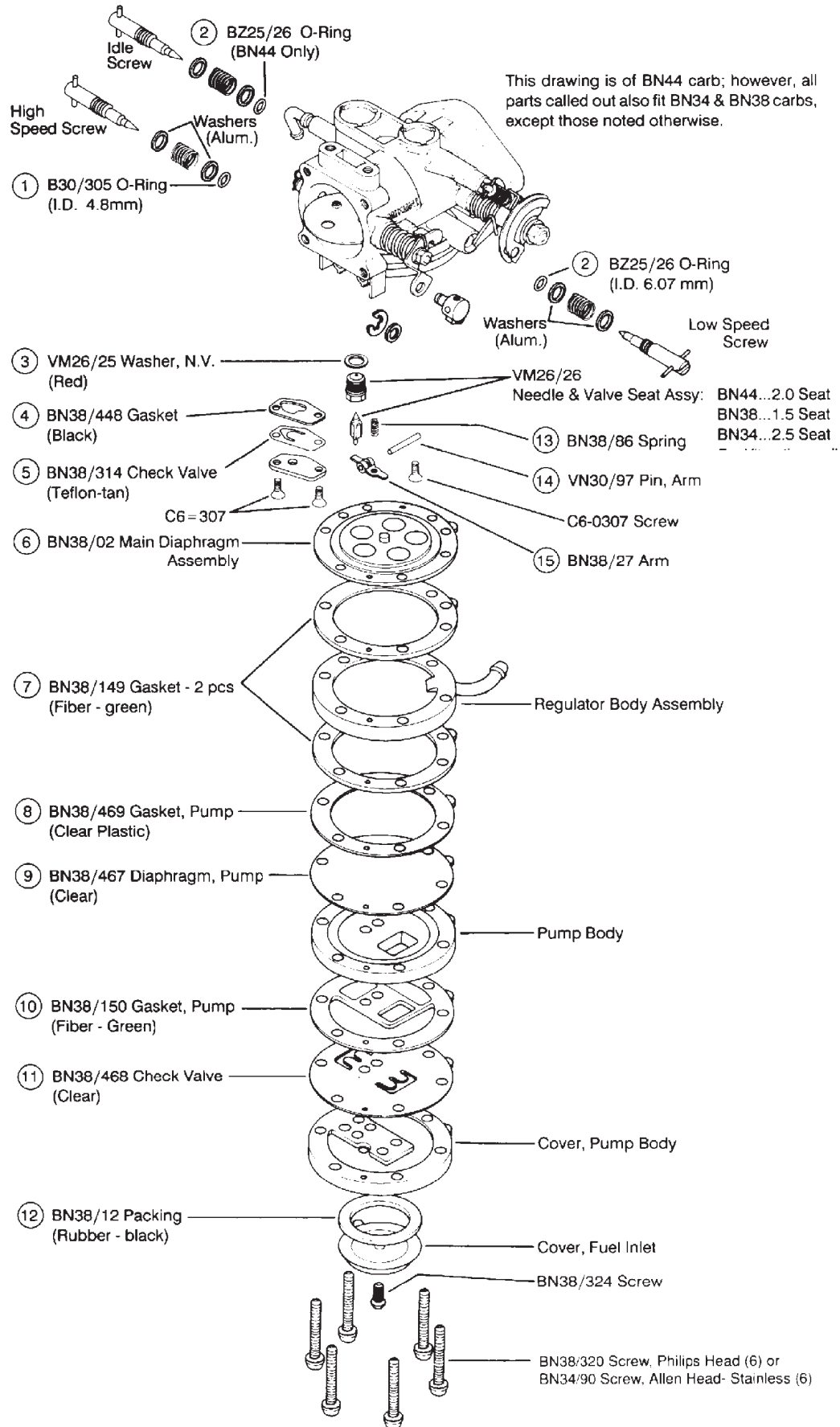



## BN38/44 Carburetor Rebuild Kit

For Standard Round BN carburetor. Kit includes genuine Mikuni parts, items 1 - 15 from drawing to rebuild one carburetor body.

**Needle Valve not included in kit. Made in Japan.**

Mikuni No. MK-BN38/44

Order No. **025-650**

**Application:** BN34, BN38 & BN44 Round Pump Carburetor.

**Application, Kawasaki:** JS300A SX (87-91), JS300B (86-88), JS440A3-A14 (77-90)

**Application, Yamaha:** WJ500 Wave Jammer (87-89), WR500 Wave Runner (87-89)



## Needle Valve Sets for BN34/38/44

Genuine Mikuni replacements. Set includes metal tip needle valve and screw-in type needle valve seat. **Washer not included, Use 002-188.**

Size	Mikuni No.	Order No.
1.0	VM26/26-1.0	<b>002-230</b>
1.2	VM26/26-1.2	<b>002-234</b>
1.5	VM26/26-1.5	<b>002-231</b>
1.5	VM26/185-1.5 (Viton Tip)	<b>002-232</b>
2.0	VM26/26-2.0	<b>002-189</b>
2.5	VM26/26-2.5	<b>002-190</b>
2.8	VM26/26-2.8	<b>002-191</b>
	VM26/25 - Washer	<b>002-188</b>



## Needle Valve Upgrade Kit for BN38/44

Kit includes 2.5 needle valve seat with viton tip needle valve, 65 gram spring, and washer for 14 lbs. "pop off".

Mikuni No. MK-BN38/44NV Order No. **007-330**

## Needle Valve Sets with Viton Tip for BN38/44

Genuine Mikuni replacements. Set includes viton tip needle valve with clip and screw-in type needle valve seat.

**Washer not included, Use 002-188.**

Size	Mikuni No.	Order No.
1.5	786-15005-1.5	<b>002-890</b>
2.0	786-15005-2.0	<b>002-891</b>
2.5	786-15005-2.5	<b>002-892</b>
	VM26/25 - Washer	<b>002-188</b>



Photo courtesy of Pro-Tec

# Mikuni Super BN (Square Pump Body)

## Super BN Carburetor Rebuild Kit (see next page)

MK-BN38/44SPR - For Super BN38, BN44, and BN381, BN401

Square Pump Styles. **Rebuild Kit includes parts 1 through 16**

**to rebuild one carburetor.**

No.	Description	Mikuni No.	Order No.
1.	Gasket, Pump (Black Fiber) (2)	BN38/547	_____
1A.	O-Ring, Pump Body	616-72001	_____
2.	Diaphragm, Pump (Clear)	BN34/97	_____
3.	Check Valve (Clear) (2)	BN34/124	_____
4.	Grommet, Check Valve (2)	BN34/125	_____
5.	Diaphragm, Damper (Black Rubber) (BN44 only)	BN34/100	_____
5A.	Diaphragm, Damper (Black Rubber) (BN38 and later BN44)	BN34/129	_____
6.	Gasket, Damper (Black) (BN44 only)	BN34/100	_____
6A.	O-Ring (BN38 and later BN44)	616-92007	_____
7.	Filter	BN44/146	_____
8.	O-Ring, Hi Speed	B30/305	_____
9.	O-Ring, Low Speed	MD12/16	_____
10.	O-Ring, Needle Valve	KV/10	<b>002-709</b>
11.	Gasket, Valve Body	BN34/123	_____
12.	Check Valve (Clear)	BN34/107	<b>007-492</b>
13.	Spring, Arm (115 grams)	730-03027	<b>007-323</b>
14.	Pin, Arm	VM30/97	_____
15.	Arm (Stainless)	BN38/534	_____
16.	Diaphragm Assembly, Main	BN44/145	<b>007-307</b>

## Super BN Replacement Parts

(Items 17-43 shown for reference only. Not included in Rebuild Kit)

17.	Screw with Washer, Stainless (4)	BN34/120-30	<b>007-302</b>
18.	Cover, Pump (Unpainted)	BN34/95B	<b>007-310</b>
	Cover, Pump (Black)	999-642-002-1A	<b>007-311</b>
	Cover, Pump (Silver)	999-642-002-1B	<b>007-312</b>
	Cover, Pump (Red)	999-642-002-1C	<b>007-313</b>
18A.	Fuel Pump Block Off Plate	BN34/126	<b>007-309</b>
19.	Body Assembly, Pump (BN44 only)	BN34/98	_____
19A.	Body Assembly, Pump (BN38 and later BN44)	BN34/128	_____
20.	Stop Screw, Idle (BN44 only)	BN34/109	_____
20A.	Stop Screw, Idle (BN38 and later BN44)	BN34/82	_____
21.	Washer, (Aluminum)	BN38/39	<b>007-304</b>
22.	Spring, Idle (BN44 only)	BN38/341	<b>007-491</b>
22A.	Spring, Idle (BN38 and later BN44)	BN38/344	<b>007-316</b>
23.	Cap (BN44 only)	BN26/03	_____
23A.	Cap with Tab (BN38 and later BN44)	BN44/118	_____
24.	Adjuster, Hi Speed	604-25017	<b>007-315</b>
24A.	Adjuster, Hi Speed	BN44/167	_____
25.	Spring, Hi Speed	BN38/344	<b>007-316</b>
26.	Washer, Hi Speed (Aluminum)	BN38/39	<b>007-304</b>
27.	Washer, Low Speed (Aluminum)	BN38/172	<b>007-305</b>
28.	Spring, Low Speed	BN38/343	<b>007-318</b>
29.	Adjuster, Low Speed (BN44)	604-26008	<b>007-317</b>
29A.	Adjuster, Low Speed (BN38 and later BN44)	BN38/477	_____
29B.	Adjuster, Low Speed	BN38/166	_____
30.	Cap	BN44/118	_____
31.	Needle Valve Assembly (see next page for additional sizes)	786-35015-1.5	<b>002-880</b>
32.	Spring Clip, N.V.	VM15/285	_____
33.	Plate, N.V. Retainer	BN34/117-GG	_____
34.	Screw with Washer	CW2=0307-G	<b>007-494</b>
35.	Jet, Slow Speed	N100.606	<b>Pg.517</b>
36.	Jet, High Speed	N102.221	<b>Pg.517</b>
37.	Screw	BV15/121-05-GG	_____
38.	Plate, Valve	BN34/108-GG	_____
39.	Valve Body Assembly	BN44/165	_____

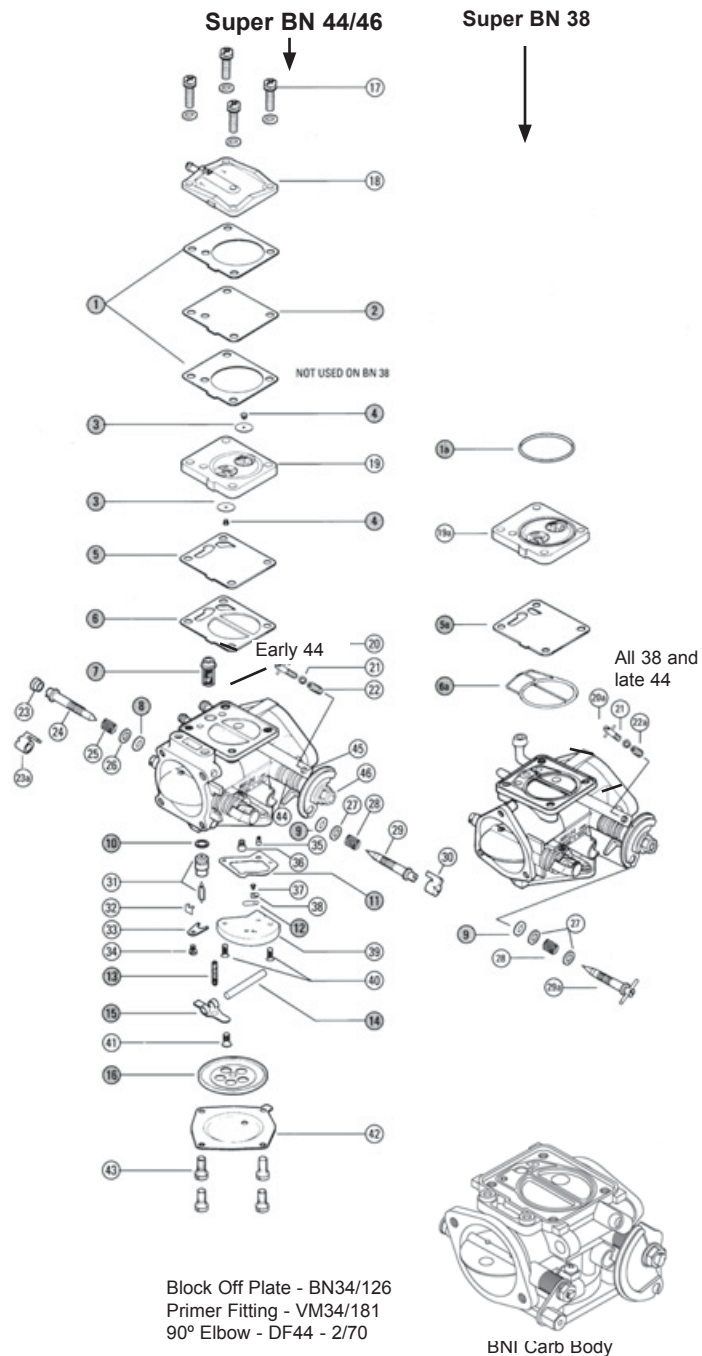

No.	Description	Mikuni No.	Order No.
40.	Screw, 4 x 14mm	C5-0414-G	<b>007-493</b>
41.	Screw, 3 x 8mm	C6-0308-G	<b>007-300</b>
42.	Cover, Stainless	BN44/147	_____
43.	Screw with Washer, Stainless (4)	MCWS-0512	<b>007-270</b>
44.	Spring (not shown in drawing)	BN34/110	_____
45.	Bushing	BN34/111	_____
46.	Nut	B401/35	_____



## Super BN38/44 -SPR Carburetor Rebuild Kit

Kit includes genuine Mikuni parts, items 1 - 16 from drawing to rebuild one carburetor body. **Does not include Needle Valve. Made in Japan.**

Mikuni No. MK-BN38/44, Order No. **025-651**

Application: Super BN38, BN44, BN46 with square diaphragm cover, BN38I, BN40I with square diaphragm cover, Kawasaki 750 series 98-02.



## Needle Valve Sets for Super BN38/44/46

Genuine Mikuni replacements. Set includes solid needle valve with viton tip and clip, needle valve seat and o-ring.

Size	Mikuni No.	Order No.
1.5	786-35015-1.5	<b>002-880</b>
1.8	786-35015-1.8	<b>002-884</b>
2.0	786-35015-2.0	<b>002-881</b>
2.3	786-35015-2.3	<b>002-882</b>
2.5	786-35015-2.5	<b>002-883</b>
	VM26/25 - Washer	<b>002-188</b>



## Pop-Off Pump

Mikuni's Pop-Off pump features a precision dial gauge. This allows accurate testing and adjustment of pop-off spring pressure. Sold each. Order by gauge reading needed.

Description	MikuniReference	Order No.
30 lb. Gauge	MK-BN-PMP30	<b>002-994</b>
100 lb. Gauge	MK-BN-PMP100	<b>002-993</b>



007-320



007-321



007-322

## Needle Valve Arm Springs

Available in different spring rates to vary pop-off pressure.

Description	Color	Mikuni No.	Order No.
65 Grams	Shiny Silver	730-03030	<b>007-320</b>
80 Grams	Black	730-03033	<b>007-321</b>
95 Grams	Dull Silver	730-03027-T	<b>007-322</b>
115 Grams	Shiny Silver		<b>007-323</b>



Photo courtesy of Pro-Tec

## Tuning Components for Super BN

### Pilot (Slow Speed) Jets

**N100.606** Sizes 50 through 150 in increments of 2.5

### Main (High Speed) Jets

**N102.221** Sizes 50 through 200 in increments of 2.5

### Needle Valve Assembly

**786-35015** Sizes 1.5, 1.8, 2.0, 2.3, and 2.5

# Mikuni BN461 (Square Carb Type)

## BN461 Carburetor Rebuild Kit

MK-BN461 and MK-BN441 Yamaha - See next page for models.

Rebuild Kit includes parts 1 through 18.

No.	Description	Mikuni No.	Order No.
1.	Gasket, Pump	BN461/13	_____
2.	Diaphragm, Pump (Clear)	BN461/14	_____
3.	O-Ring	616-73002	_____
4.	Check Valve (2)	BN461/11	_____
5.	Grommet (2)	BN34/125	_____
6.	Diaphragm, Damper	BN461/34	_____
7.	Diaphragm, Damper (Clear)	BN461/15	_____
8.	O-Ring	616-73003	_____
9.	Filter, Fuel	BN44/146	_____
10.	O-Ring, Hi Speed (2)	B30/305	_____
11.	O-Ring, Low Speed	MD12/16	_____
12.	O-Ring, Needle Valve	KV/10	<b>002-709</b>
13.	Gasket, Valve Body	BN34/123	_____
14.	Check Valve (Clear)	BN34/107	<b>007-492</b>
15.	Pin, Arm	VM30/97	_____
16.	Spring, Arm (95 grams)	730-03034	_____
17.	Arm (Stainless)	BN38/534	_____
18.	Diaphragm Assembly, Main	BN44/145	<b>007-307</b>

## BN461 Replacement Parts

(Items 19-42 shown for reference only. Not included in Rebuild Kit.)

19.	Screw with Washer (4)** (see **Tightening Torque)	BN34/120-35	_____
20.	Cover, Pump	BN461/xx	_____
21.	Body Assembly, Pump	BN46/49	_____
22.	Stop Screw, Idle	BN38/40	_____
23.	Washer, Aluminum, (3) Hi Speed (1) and Stop Screw (2)	BN38/39	<b>007-304</b>
24.	Spring (2)	BN38/344	_____
25.	Cap, Hi Speed Adjuster	999-904-006	<b>007-316</b>
26.	Adjuster, Hi Speed	604-25017	<b>007-315</b>
27.	Washer, Low Speed (Aluminum) (2)	BN38/172	<b>007-305</b>
28.	Spring, Low Speed	BN38/343	<b>007-318</b>
29.	Adjuster, Low Speed	BN38/477	_____
30.	Jet, High Speed	N102.221	<b>Pg.517</b>
31.	Jet, Low Speed	N100.606	<b>Pg.517</b>
32.	Screw	BV15/121-05-GG	_____
33.	Plate, Valve	BN34/108-GG	_____
34.	Valve Body Assembly	BN44/165	_____
35.	Screw 4 x 14mm (2)	C5=0414-G	<b>007-494</b>
36.	Needle Valve Assembly	786-35018-1.8	<b>002-884</b>
<i>(see next page for additional sizes)</i>			
37.	Plate, Needle Valve Retainer		_____
38.	Screw with Washer 3 x 7mm	CW2=0307-G	<b>007-493</b>
39.	Screw 3 x 8mm	C6=0308-G	<b>007-300</b>
40.	Cover (Stainless)	BN44/147	_____
41.	Screw, 5 x 14mm (4) **	C2S=0514	<b>007-625</b>
<i>(see **Tightening Torque)</i>			
42.	Diaphragm, Accelerator Pump	BN40I/22	_____

\*\*Tightening Torque:

Part No. 19: 4.5 N/m (45 Kg/Cm)

Part No. 41: 3.5 N/m (35 Kg/Cm)

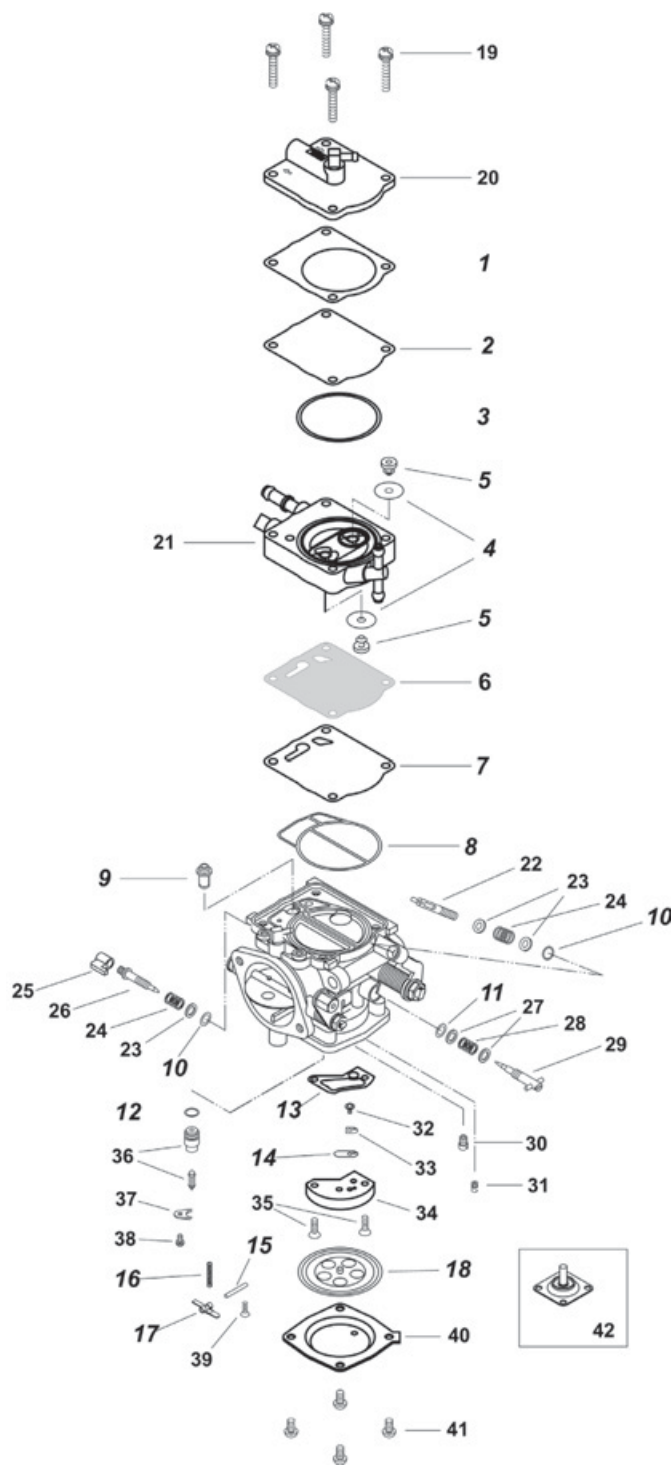





## BN46I Carburetor Rebuild Kit

Kit includes genuine Mikuni parts, items 1 - 18 from drawing to rebuild one carburetor body. **Does not include Needle Valve. Made in Japan.**

**Mikuni No.** MK-BN46I      **Order No.** 025-654

**Application:** Super BN46I with square diaphragm cover, Sea-Doo models (1998 and newer) with dual carbs.



## BN44I Carburetor Rebuild Kit for Yamaha

Kit includes genuine Mikuni parts, items 1 - 18 from drawing to rebuild one carburetor body. **Does not include Needle Valve.** Yamaha watercraft applications. **Made in Japan.**

**Mikuni No.** MK-BN44I      **Order No.** 025-653

**Application:** Super BN44I - Yamaha models with square diaphragm cover. GP800 (98-99), GP800R (00-04), XL800 (02-04), XLT800 (02-04), GP1200R (00-02), XL1200 Limited (99-00), XLT1200 (01-04)



## Pop-Off Pump

Mikuni's Pop-Off pump features a precision dial gauge. This allows accurate testing and adjustment of pop-off spring pressure. Sold each. Order by gauge reading needed.

Description	Mikuni Reference	Order No.
30 lb. Gauge	MK-BN-PMP30	002-994
100 lb. Gauge	MK-BN-PMP100	002-993



## Needle Valve Sets for BN46I

Genuine Mikuni replacements. Set includes solid needle valve with viton tip and clip, needle valve seat and o-ring.

Size	Mikuni No.	Order No.
1.5	786-35018-1.5	002-900
1.8	786-35018-1.8	002-897
2.0	786-35018-2.0	002-898
2.5	786-35018-2.5	002-899

## Tuning Components for BN46I

### Pilot (Slow Speed) Jets

**N100.606** Sizes 50 through 150 in increments of 2.5

### Main (High Speed) Jets

**N102.221** Sizes 50 through 200 in increments of 2.5

### Needle Valve Assembly

**786-35018** Sizes 1.5, 1.8, 2.0, 2.3, and 2.5



## Sudco 7.50mm Valve Adjustment Shim Kits

Sudco shims are OEM specific dimensions for proper fitment. (7.47mm - 7.49mm) Available in shop kit and individual sizes. Individual sizes sold each. **Made in Japan.**

### 7.5mm Diameter Dealer Shim Kit 1.35mm - 2.15mm (total 34 shims)

Order No. **035-001**

Includes storage box and qt 2 each size of the following:

1.35, 1.40, 1.45, 1.50, 1.55, 1.60, 1.65, 1.70, 1.75, 1.80, 1.85  
1.90, 1.95, 2.00, 2.05, 2.10, 2.15

### 7.5mm Diameter Dealer Shim Kit 2.20mm - 3.00mm (total 34 shims)

Order No. **035-002**

Includes storage box and qt 2 each size of the following:

2.20, 2.25, 2.30, 2.35, 2.40, 2.45, 2.50, 2.55, 2.60, 2.65, 2.70  
2.75, 2.80, 2.85, 2.90, 2.95 3.00

### Shim Storage Box

Order No. **008-001**

## 7.50mm Valve Adjustment Shims

Sizes available from 1.35 mm thickness - 3.00mm thickness. Sold each.

Size	Order No.	Size	Order No.
1.35mm	<b>035-100</b>	2.20mm	<b>035-117</b>
1.40mm	<b>035-101</b>	2.25mm	<b>035-118</b>
1.45mm	<b>035-102</b>	2.30mm	<b>035-119</b>
1.50mm	<b>035-103</b>	2.35mm	<b>035-120</b>
1.55mm	<b>035-104</b>	2.40mm	<b>035-121</b>
1.60mm	<b>035-105</b>	2.45mm	<b>035-122</b>
1.65mm	<b>035-106</b>	2.50mm	<b>035-123</b>
1.70mm	<b>035-107</b>	2.55mm	<b>035-124</b>
1.75mm	<b>035-108</b>	2.60mm	<b>035-125</b>
1.80mm	<b>035-109</b>	2.65mm	<b>035-126</b>
1.85mm	<b>035-110</b>	2.70mm	<b>035-127</b>
1.90mm	<b>035-111</b>	2.75mm	<b>035-128</b>
1.95mm	<b>035-112</b>	2.80mm	<b>035-129</b>
2.00mm	<b>035-113</b>	2.85mm	<b>035-130</b>
2.05mm	<b>035-114</b>	2.90mm	<b>035-131</b>
2.10mm	<b>035-115</b>	2.95mm	<b>035-132</b>
2.15mm	<b>035-116</b>	3.00mm	<b>035-133</b>

## Honda

Model	Year
ARX1200N2 Aquatrax R-12	04-06
ARX1200N3 Aquatrax F-12	02-06
ARX1200T2 Aquatrax R-12X	03-06
ARX1200T3 Aquatrax F-12X	02-06
ARX1200T3D Aquatrax F-12XGP Scape	02-06

## Yamaha

Model	Year
FX1000 Wave Runner	05-06
FX1000 Wave Runner Cruiser	05-06
FX1100 Wave Runner Cruiser H.O.	04-06
FX1100 Wave Runner H.O.	04-06
VX1100 Wave Runner Deluxe	05-06
VX1100 Wave Runner Sport	05-06

## Sudco 9.50mm Valve Adjustment Shim Kit

Sudco shims are OEM specific dimensions for proper fitment. Available in shop kit and individual sizes. Individual sizes sold each. **Made in Japan.**

### 9.5mm Diameter Dealer Shim Kit 2.35mm - 3.30mm (total 34 shims)

Order No. **035-006**

Includes storage box and qt 2 each size of the following:

2.35, 2.40, 2.45, 2.50, 2.55, 2.60, 2.65, 2.70, 2.75, 2.80, 2.85  
2.90, 2.95, 3.00, 3.05, 3.10, 3.15, 3.20, 3.25, 3.30.

### Shim Storage Box

Order No. **008-001**

## 9.50mm Valve Adjustment Shims

Sizes available from 2.35 mm thickness - 3.30mm thickness. Sold each.

Size	Order No.	Size	Order No.
2.35 mm	<b>035-220</b>	2.85mm	<b>035-230</b>
2.40 mm	<b>035-221</b>	2.90mm	<b>035-231</b>
2.45mm	<b>035-222</b>	2.95mm	<b>035-232</b>
2.50mm	<b>035-223</b>	3.00mm	<b>035-233</b>
2.55mm	<b>035-224</b>	3.05mm	<b>035-234</b>
2.60mm	<b>035-225</b>	3.10mm	<b>035-235</b>
2.65mm	<b>035-226</b>	3.15mm	<b>035-236</b>
2.70mm	<b>035-227</b>	3.20mm	<b>035-237</b>
2.75mm	<b>035-228</b>	3.25mm	<b>035-238</b>
2.80mm	<b>035-229</b>	3.30mm	<b>035-239</b>

## Kawasaki

Model	Year
JT1200B1/B2 Jet Ski STX12F	03-04
JT1200D1/D6F/D7F Jet Ski STX12F	05-07
JT1500A1/A2 Jet Ski STX15F	04-05
JT1500A6F/A7F/A8F Jet Ski STX15F	06-08

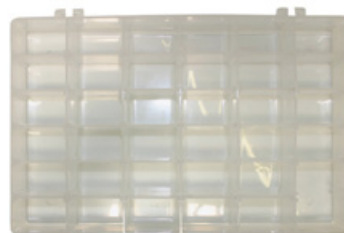

**008-001**



**008-002**

## Sudco Plastic Jet Boxes (Storage Boxes)

Two boxes available, 36 compartment and 18 compartment. Use for valve shim storage, small parts, electrical connectors and carburetor jets. Sold each.

Description	Order No.
Jet Box with 36 Compartments 7-1/2" L x 10-1/2" L x 1-1/4" H	<b>008-001</b>
Jet Box with 18 Compartments 3-1/4" L x 6-3/4" L x 1-1/2" H	<b>008-002</b>



## Vesrah Gasket Sets for Kawasaki JS440

Sold in sets. *Made in Japan.*

### Kawasaki

Model	Year	Complete	Top End
JS440A1/A2/A3/A4	77-81	<b>608-672</b>	<b>609-672</b>
JS440A5-A16	82-92	_____	<b>609-673</b>



## Cylinder Head Gaskets for Kawasaki JS440

Stock replacements. Sold pk/5. *Made in Japan.*

### Kawasaki

Model	Year	OEM Ref.	Order No.
JS440A1/A2/A3/A4	77-81	11004-3711	<b>609-872</b>



## Copper Cylinder Head Gaskets

Quality high compression head gaskets are 40% thinner than stock replacement. Sold each. *Made in Japan.*

### Kawasaki

Model	Year	Order No.
JS440A1/A2/A3/A4	77-81	<b>609-801</b>
JS440A5-A16	82-92	<b>609-802</b>
JS550A1-A8	82-89	<b>609-803</b>
JS550B1 SX	1990	<b>609-803</b>



Photo courtesy of Pro-Tec



## ART Personal Watercraft Piston Kits

All ART Piston Kits come with piston, ring set, wrist pin, and clips.

Order one per cylinder, some models listed require 2 kits. *Made in Japan.*

### Kawasaki

Model	Year	Size	Piston Kit	Piston Ring
JS300A1/A2/A3 300 SX	87-89	STD	_____	_____
JS300B1/B2/B3	86-88	0.50mm	_____	_____
		1.00mm	_____	<b>624-642R</b>
		1.50mm	_____	<b>624-643R</b>
JS440A1-A16	77-92	STD	_____	_____
		0.50mm	_____	<b>624-621R</b>
		1.00mm	_____	<b>624-622R</b>
		1.50mm	<b>624-623</b>	<b>624-623R</b>
JS550A1-A8	82-89	STD	_____	_____
JS550B1 SX (single ring piston)	1990	0.50mm	_____	_____
		1.00mm	_____	_____
		1.50mm	_____	<b>624-633R</b>
JB650A1/A2/A3/A4	89-92	STD	_____	_____
JF650A1-A9 X-2	86-94	0.50mm	_____	_____
JF650B1-B8 Tandem Sport	89-96	1.00mm	_____	<b>624-642R</b>
JL650A1/A2/A3 Sport Cruiser	91-93	1.50mm	_____	<b>624-643R</b>
JS650A1/A2/A3/A 650SX	87-90			
JS650B1/B2/B3 650SX	91-93			
JH750		STD	_____	_____
		0.50mm	_____	<b>624-681R</b>
		1.00mm	_____	<b>624-682R</b>
		1.50mm	_____	<b>624-683R</b>

### Yamaha

700/1100 Raider	STD	_____	<b>624-690R</b>
	0.50mm	_____	<b>624-691R</b>
	1.00mm	_____	<b>624-692R</b>
	1.50mm	_____	<b>624-693R</b>

## Piston Pin Bearing

Sold each. *Made in Japan.*



### Kawasaki

Model	Year	OEM Reference	Order No.
JS300A1-A5 300 SX	87-91	13033-1010	<b>623-930</b>
JS300B1/B2/B3	86-88	13033-1010	<b>623-930</b>
JB650A1/A2/A3/A4 Jet Mate	89-92	13033-1010	<b>623-930</b>
JF650A1-A10 650 X2	86-95	13033-1010	<b>623-930</b>
JF650B1-B8 Tandem Sport	89-96	13033-1010	<b>623-930</b>
JL650A1/A2/A3/A4/A5 SC	91-95	13033-1010	<b>623-930</b>
JS650A1/A2/A3/A4 650 SX	87-90	13033-1010	<b>623-930</b>
JS650B1/B2/B3 650 SX	91-93	13033-1010	<b>623-930</b>

# Connecting Rod Kits & Oil Filters



631-7204

631-7303



631-7303C

## Vesrah Connecting Rod Kits

Vesrah connecting rod kits for watercraft models include connecting rod, crank pin bearing, crank pin, thrust washers and piston pin bearing.

Made in Japan.

### Kawasaki

Model	Year	Vesrah Ref.	Order No.
JS440A1-A16	77-92	VA-4902	623-650
JS550A1-A8	82-89	VA-4902	623-650
JS550B1 SX	1990	VA-4902	623-650
JB650A1/A2/A3/A4	89-92	VA-4905	623-670
JF650A1-A9 X-2	86-94	VA-4905	623-670
JF650B1-B8 Tandem Sport	89-96	VA-4905	623-670
JL650A1/A2/A3 Sport Cruiser	91-93	VA-4905	623-670
JS650A1/A2/A3/A 650SX	87-90	VA-4905	623-670
JS650B1/B2/B3 650SX	91-93	VA-4905	623-670

### Yamaha

SJ650D/P/Q/R Super Jet	90-93	VA-4952	623-660
VXR650P Wave Runner	1991	VA-4952	623-660
WR650D/P/Q/R Wave Runner LX	90-93	VA-4952	623-660
WRA650D/P/Q/R Wave Runner III	90-93	VA-4952	623-660
WRA650T/U Wave Runner III	95-96	VA-4952	623-660
WRA650AR Wave Runner Dix	1993	VA-4952	623-660
WRB650P-T Wave Runner VXR	91-95	VA-4952	623-660
WRB650AR Wave Runner VXR Dix	1993	VA-4952	623-660
FX700T/U FX-1	94-95	VA-4952	623-660
RA700S/T Wave Raider 80	94-95	VA-4952	623-660
RA700AT	1995	VA-4952	623-660
RA700BU/BV Wave Raider 80	96-97	VA-4952	623-660
SJ700S/T Super Jet	94-95	VA-4952	623-660
SJ700AU/AV/AW/AX Super Jet	96-99	VA-4952	623-660
WB700R/S/T Wave Blaster	93-95	VA-4952	623-660
WB700AU Wave Blaster	1996	VA-4952	623-660
WRA700S/T Wave Runner III GP	94-95	VA-4952	623-660
WRA700V Wave Runner III GP	1997	VA-4952	623-660
WRB700R/S Wave Runner Pro VXR	93-94	VA-4952	623-660
WVT700T/U/V/W Wave Venture	95-98	VA-4952	623-660
XL700X Wave Runner	1999	VA-4952	623-660
RA1100T/U Wave Raider	95-96	VA-4952	623-660
WVT1100U/V Wave Runner 3-P	96-97	VA-4952	623-660

## K&N Oil Filters for Watercraft

Spin-on oil filters for personal watercraft applications. Sold each.

### Honda

Model	Year	K&N No.	Order No.
ARX1200N2 Aquatrax R-12	04-06	KN-204	631-7204
ARX1200N3 Aquatrax F-12	02-06	KN-204	631-7204
ARX1200T2 Aquatrax R-12X	03-06	KN-204	631-7204
ARX1200T3 Aquatrax F-12X	02-06	KN-204	631-7204
ARX1200T3D Aquatrax F-12XGP Scape	02-06	KN-204	631-7204

### Kawasaki

JT1200 STX-12F	03-07	KN-204	631-7204
JT1500 STX-15F	04-08	KN-204	631-7204

### Yamaha

FX1000 Wave Runner	05-06	KN-303	631-7303
FX1000 Wave Runner Cruiser	05-06	KN-303	631-7303
FX1100 Wave Runner Cruiser H.O	04-06	KN-303	631-7303
FX1100 Wave Runner H.O.	04-06	KN-303	631-7303
VX1100 Wave Runner Deluxe	05-06	KN-303	631-7303
VX1100 Wave Runner Sport	05-06	KN-303	631-7303
Chrome Oil Filter		KN303C	631-7303C

Option for all the above models



## Kawasaki Personal Watercraft Flywheel Puller M18mm x 1.5mm R.H.

Solid Puller Bolt. Allows you to pull flywheel without pulling motor from hull. Motion Pro Reference 08-0118. Sold each.

Order No. 950-470

### Kawasaki

JH750A/E (92-96), JH750B/F (93-96), JH750C (95-96)
JS750A (92-95), JS750B (95-96), JT750A (94-95), JT750B (95-96)



## PC Racing Engine Hour Meter

Automatically records and displays your engines accumulated run time, so oil changes, piston, rings, valves, spark plugs, etc. can be serviced at the correct maintenance schedule. The correct schedule saves costly engine damage from service neglect, but Motominder can also save money from servicing too frequently. The smallest engine hour meter available (Approximately 1" x 1.5") it doesn't require additional mounting bracket and can be easily mounted by the peel and stick method to the frame or other convenient area. PC Racing is so confident that motominder is the most reliable engine hour meter available that it is backed by a 2-year manufacturer's replacement warranty. Works with all Gas Engines.

Description	Order No.
PCMM1	945-130



## Three Bond Griplock TB1501C

Keeps grips in place without damaging the rubber. Sold in 1 oz. tube.

Order No. [800-155](#)



## Two-Stroke Racing Oil

Red Line's popular two-stroke lubricants contain base oil which have the highest film strength and greatest affinity for hot metal. Because Red Line is a superior high temperature lubricant, it can be used at lower fuel to oil ratios, increasing power and providing excellent scuff protection and cleanliness. Where many two-stroke oils are recommended to run 32:1, many Red Line customers often mix at a leaner 40:1. Red Line provides the lubricating cleanliness, with low carbon residue that dramatically reduces plug fouling and smoke. Red Line provides special protection for formulated fuels. Dyno proven to make more power over longer periods of operating time.

Sold in 16 oz. and gallon bottles.

Description	Qt	Order No.
2-Stroke All Sport	16 oz	900-833
2-Stroke Alcohol	16 oz	900-848
2-Stroke Race	16 oz	900-830
2-Stroke Kart	16 oz	900-831
Watercraft & Injection	1 gallon	900-854
2-Stroke Race	1 gallon	900-829
2-Stroke Kart	1 gallon	900-832

#	
11-Slot T-Handle Rack, Motion Pro	501
13mm Valve Adjustment Shims	32, 342
2-Stroke Leakdown Tester, Motion Pro	502
2-Stroke Racing Oil, Redline	490
25mm Valve Adjustment Shims	33, 343
29.5mm Valve Adjustment Shims	35, 345
29mm Valve Adjustment Shims	34, 344
3 PC.T-Handle Phillips Set, Motion Pro	501
4-Stroke Alcohol Fuel Lube, Redline	491
4-Stroke Leakdown Tester, Motion Pro	502
40° Cable Adjuster Assembly	201
45° Cable Adjuster	201
5 PC. Mini-Pro T-Handles, Motion Pro	501
6 PC. Racer T-Handles Set, Motion Pro	501
7 PC. Metric T-Handles, Motion Pro	501
7 Way Crimping Tool (CT-1)	500
7.50mm Valve Adjustment Shims	340
80W Motorcycle Gear Oil with ShockProof, Red Line	491
9.50mm Valve Adjustment Shims	341
90-Degree 1/4" Hex Driver, Motion Pro	496
90° Angle Fuel Filters	268
90° Cable Adjuster Assembly	141

## A

Accelerator Pump Cover	230
Accelerator Pump Rebuild Kit	19, 113, 115
Accelerator Pump Rebuild Kit	230-231
Accelerator Pump Rebuild Kit, K&L	19
Accessories for Sync Pro Carburetor Tuner	494
Adjustable Cam Sprocket Assemblies, APE	43, 358-359
Air Box Adapters & Manifolds	217
Air Box Complete, Kawasaki H2-750	9
Air Box, Kawasaki Z1 900 73-75 Replica	9
Air Cleaner Adapter O-Ring, Keihin FCR	121
Air Cut-Off Valve Set, K&L	19
Air Cut-Off Valve Sets, K&S	232-235
Air Filter Gasket, PC Racing Pro Seal	278
Air Filter Sets, K&N Custom Clamp On	274-277
Air Filter Skins, PC Racing	279
Air Filters, K&N	270-278
Air Filters, K&N ATV OE Replacement	272
Air Filters, K&N OE Replacement	8, 270-271
Air Filters, K&N Universal Clamp-On	277
Air Filters, OEM Type Replacement	8
Air Filters, PC Racing Flo	278
Air/Fuel Ratio Monitor, K&N	236
Airbox Kits for Honda CR/CRF, Pro-Seal	279
All-In-One RTV Silicone	486
Alternator Block Off Cover, APE	363

## A

Aluminum Body Fuel Filters	268
Amal to Mikuni Rubber Mounting Flanges	219
Anaerobic Thread Locks, Three Bond	484
Angle Fuel Filters, 90°	268

## APE

Adjustable Cam Sprocket Assemblies	43, 358-359
Alternator Block Off Cover	363
Breather Block Off Plate, Suzuki GS1100	345
Cam Chain Conversion Kit	359
Cylinder Studs	45, 351
Heavy Duty Cylinder Head Nuts	351
Heavy Duty Cylinder Head Studs	45, 351
Heavy Duty Main Bearing Studs	363
High Performance Valve Guides	41, 353
High Performance Valve Springs	352
Kawasaki Cam Chain Adapter Drill Jig	42, 353
Kawasaki Cam Chain Idler Adapter	42, 353
Kawasaki Cam Cover Caps	345
Kawasaki Kick Start Block Off Cover	363
Kawasaki Low Profile Breather Cover	363
Kawasaki Low Profile Oil Filter Cover	363
Kawasaki Main Bearing Support Cap	363
Kick Start Block Off Cover	363
Low Profile Breather Cover	363
Manual Cam Chain Tensioners	354-356
Manual Cam Chain Tensioners (Vintage)	42
Positive Stop TDC Tools	503
Suzuki GS1100 Breather Block Off Plate	345
Titanium Valve Spring Retainers	352

## ART

ATV Piston Kits	368
Personal Watercraft Piston Kits	525
Assembly Lube, Redline	491
ATV & Offroad Throttle Cables, Motion Pro	445
ATV & Offroad Throttle Cables, Motion Pro	445
ATV Axle Wrench, Motion Pro	500
ATV Carburetor Repair Kits	240-241
ATV Connecting Rod Kits, Vesrah	370-371
ATV Disc Brake Rotors, Vesrah	465
ATV Engine Oil Seal Kits, K&S	320-321
ATV Headlight (Closeout)	480
ATV Intake Manifolds, UPP	218
ATV OEM Replacement Air Filters, K&N	272
ATV Piston Kits, Art	368
ATV Piston Kits, Shindy Products	369
ATV Pre Charger, K&N	273
ATV Stators	94
ATV Terminator Clutch Cables, Motion Pro	444

<b>A</b>	
ATV Twist Throttle Kit, Motion Pro	443
Auxiliary Gas Tanks, Motion Pro	495
<b>B</b>	
Banshee Carburetor Cable Kits	237, 441
Base Gaskets, Vesrah	26, 287-289
Batteries, Power Source	481
Battery Booster Cable Set, Motion Pro	499
Bead Popper, Motion Pro	507
BeadPro Tire Bead Breaker and Lever Tool Set	507
Billet Metal Polish	483
Black Label Chain Lube, PJ1	488
Blaster/Banshee Carburetor Caps	237, 441
Blue Label Chain Lube, PJ1	488
BN (Round Pump Carb Type), Mikuni	518-519
BN Carburetor Parts & Accessories, Mikuni	517
BN Round Pump Carb Type Exploded View, Mikuni	518
BN38/44 Carburetor Rebuild Kit, Mikuni	519
BN44I Carburetor Rebuild Kit for Yamaha, Mikuni	523
BN46I (Square Carb Type), Mikuni	522-523
BN46I Carburetor Rebuild Kit, Mikuni	523
BN46I Replacement Parts, Mikuni	522
BN46I Square Carb Type Exploded View	522
Body Parts, Vintage	73
Bolt Seals. Valve (Head) Cover	304-307
Boyer Bransden Electronic Ignition	75, 474
Brake Bleeding Kit, Mityvac	440, 504
Brake Bleeder, Motion Pro Mini	504
Brake Bleeder, Motion Pro Hydraulic	504
Brake Caliper Pistons, Honda	59
Brake Calipers, Nissin 6-Piston	465
Brake Light Switch (Hydraulic)	444, 479
Brake Pads, Vesrah	56-57, 448-464
Brake Pedal, Z1/KZ900	60
Brake Rod, Z1/KZ900	60
Brake Shoes, Vesrah	56-57, 448-463
Brake Tools	504
Brass T-Fittings	165, 268, 498
Breather Block Off Plate, APE Suzuki GS1100	345
<b>Bulbs</b>	480
Headlight	480
Instrument	480
Tail Light	480
Turn Signal	480
<b>C</b>	
Cable Adjuster, 45°, Mikuni	201
Cable Adjuster Assembly, 40°, Mikuni	201
Cable Adjuster Assembly, 90°, Mikuni	201

<b>C</b>	
Cable Adjuster Assembly, 90°, Keihin	141
Cable Adjuster Holder, Keihin	145
Cable Lube, PJ1	65, 488
Cable Luber, Motion Pro	65, 499
Cable Mounting Brackets, Keihin FCR	112
<b>Cables</b>	
Brake (Vintage)	66-67
Choke (Vintage)	66
Clutch, Motion Pro ATV Terminator	444
Speedometer (Vintage)	66-67
Tachometer (Vintage)	66-67
Throttle, HSR	173
Throttle, Keihin FCR	119
Throttle, Motion Pro ATV & Offroad	445
Throttle, TM40 (HS40)	186
Vintage, All	65-67
California Gold Chrome Polish, Mothers	483
California Gold Natural Formula Pure Carnauba Wax, Mothers	482
California Gold Original Formula Carnauba Cleaner Wax, Mothers	482
California Gold Scratch Remover, Mothers	482
California Gold Showtime Instant Detailer, Mothers	482
Caliper Pistons, Honda Brake	59
Cam Chain Adapter Drill Jig, APE Kawasaki	42, 353
Cam Chain Conversion Kit, APE	359
Cam Chain Idler Adapter, APE Kawasaki	42, 353
Cam Chain Tensioner Pushrod Kit	43, 357
Cam Chain Tensioners, APE Manual	42, 354-357
Cam Chains, Sudco	44, 360-362
Cam Cover End Plugs, Billet	31, 344
Cam Cover End Plugs, Rubber	28-29, 300-303
Cam End Rubber Plugs, Vesrah	28-30, 300-303
Cam Sprocket Assemblies, APE Adjustable	43, 358-359
Cam Sprockets	43, 358-359
Camshaft End Rubber Plugs	30, 303
Carb Boots, UPP	218
Carb Cleaner Wire Set, K&L	496
Carb Holder Clamp	7, 222
Carb Holder Rubber Plugs, K&L	7, 222, 495
Carb Holders, Sudco Intake	6-7, 220-223
Carb Kits (Vintage), Keihin & Mikuni Street	4-5, 154-155
Carb Kits, Keihin Street	152-153
Carb Kits, Keihin Offroad	156-158
Carb Kits, Mikuni Offroad	159
Carb Pump Diaphragm Valve Sets, K&L	18, 228
Carb Service Stand, K&L	497
Carb Slide Diaphragms, Sudco Mikuni	20, 229
Carb Synchronizer	494

## C

Carb Vacuum Fitting Cap, Sudco	7, 222, 495
Carburetor Float & Float Pin	15, 244-245
Carburetor Rebuild Kit, Keihin PJ	141
Carburetor Rebuild Kit, Keihin PWK Snowmobile	139
Carburetor Rebuild Kit, Keihin PWK28	135
Carburetor Rebuild Kit, Keihin PWK33-41mm	137
Carburetor Rebuild Kit, Keihin PWM38	143
Carburetor Rebuild Kit, Mikuni VM26-606	197, 238
Carburetor Rebuild Kit, YXR 660 Rhino	243
Carburetor Rebuild Kits, Sudco	238
Carburetor Rebuild Kits, Keihin FCR	109, 113, 238
Carburetor Rebuild Kits, Keihin FCR-MX	114, 242
Carburetor Rebuild Kits, Mikuni HSR42/45/48	177, 238
Carburetor Rebuild Kits, Mikuni TM36/TM40 (HS40)	185, 238
Carburetor Repair Kits, ATV	240-241
Carburetor Repair Kits, Offroad	242-243
Carburetor Repair Kits, Vintage Street	10, 239
Carburetor Tools	494-498
Carburetor Top Cap Cover Gasket, Sudco	10
Carburetor Vent Systems, PC Racing	279
Cartridge Pro Fork Fluid, PJ1	425, 489
Case Sealant Liquid Gasket TB1184, Three Bond	485
CDK Carburetor Rebuild Kits, Keihin (Watercraft)	514
CDK/CDKII Exploded View, Keihin (Watercraft)	512-513
CDK/CDKII Parts, Keihin (Watercraft)	512-513
CDKII Parts w/Accelerator Pump, Keihin (Watercraft)	512-513
Chain Adjuster Bolt & Nut, Kawasaki	54
Chain Lube, PJ1	488
Chain Tools	506
Chain, RK Drive	54, 408-409
Charlie's Soap	493
Choke Shaft Block-Off, Keihin (Watercraft)	514
Chrome Emblems, Cycle Pirates Diamond	443
Chrome Gauge Covers, Kawasaki KZ	63
Chrome Plated Adapter Nuts, Pingel	262
Chrome Rear Shocks for H1-500 & H2-750	59
Chrome Rear Shocks for Z1/KZ900 & KZ1000	59
Chrome-Moly Hex Axle Tool, Motion Pro	504
Clear Silicone Liquid Gasket TB1212C, Three Bond	485
Clips, Sudco Fuel & Vacuum Hose	21, 268
Clutch Cable Adjuster, Z1	64
Clutch Cover Gaskets, Vesrah	48-49, 328-334
Clutch Lever, Motion Pro Quick Adjust MX	441
Clutch Levers	64, 441
Clutch Plates, Vesrah	391-407
Clutch Springs, Vesrah	391-407
Clutch Tuner Gear Oil, PJ1	487
Competition Oil Filters- Stainless Steel Element	268

## C

Condensers	86-93
Connecting Rod Kits, ATV & Offroad	370-371
Connecting Rod Kits, Sudco Kawasaki H1 & H2	47
Connecting Rod Kits, Watercraft	526
Contact Breaker Plate Assemblies	79
Contact Points, Ignition	79-85
Control Cables	65-67, 444-445
Control Levers, OEM Type	64
Control Meter Parts	63
Control Parts	62
Coolant Recovery System	498
Copper Cylinder Head Gaskets (Watercraft)	525
Cover Bolt Seals, Valve (Rubber Parts)	304-307

## CR Special, Keihin

(CRS) Replacement Parts	125
Dual Carburetor Sets	123
Jet Needles	131
Main Air Jet N424-14-XXX	130, 151
Mounting Adapters (Spigots)	126-127
Needle Valve Seats	128
Parts & Accessories	128-130
Racing Carburetors	122-123
Replacement Parts	124-125
Starter Jets (1001-108-XXX)	130, 149
Crankcase Vent Filters, K&N Rubber and Steel Base	47, 335
Crankshaft Oil Seal Kits, Kawasaki	46
Crankshaft Seal Collar Sets	47
Crimping Tool, (CT-1) 7 Way	95, 500

## Cycle Pirates

Diamond Chrome Emblems	443
Folding Brake Levers	446
Folding Shift Levers	446
Headlight Trim	447
Mirror Block-Offs	447
Cylinder Head Bolt Kit, H2-750	27
Cylinder Head Cover Bolt Seals, Kawasaki & Suzuki	309
Cylinder Head Gasket, Vesrah	26, 27, 287-289
Cylinder Head Gaskets, Kawasaki JS440	525
Cylinder Head O-Rings, Kawasaki	27, 286
Cylinder Head Studs, APE Heavy Duty	27, 351

## D

Dealer Jet Kit (Main & Slow), Genuine Keihin	133
Dealer Main and Pilot Jet Kit, Mikuni	214
Dealer Main Jet Kits, Keihin	150
Dealer Main Jet Kits, Mikuni	214
Decal Sets (Vintage)	73
Deluxe Suspension Bearing Service Tool, Motion Pro	508



**D**

Disc Brake Rotor, Front (Vintage)	61
Disc Brake Rotors, Sunstar	465
Drive Chain, RK	54, 408-409
DT1-250 Fork Tube Piston (Vintage)	55
DT1-250/RT1-360 Tail Light Lens (Vintage)	99
Dust Seal Kits, K&S Fork	410-423
Dust Boot (Dust Shield), Fork	55, 425

**Dynatek (Dyna)**

2000 Digital Performance (Vintage)	75
2000 Digital Performance Ignition for Sportbikes	475
3000 Digital Performance Ignition Module for Cruisers	474
Charge Monitor	477
Coil Kits for Yamaha	471
Electronic Ignition	475
Electronic Ignition (Vintage)	75
FS Digital Performance Ignition	476
FS Programming Kit	476
Fuel Injection Controller	236
Ignition Coil Kits for Yamaha	471
Ignition Coils	471-472
Ignition Wires	472
Mini Series Coils	472
RPM Limiter	477
Shift Minder System	477
Twin Fire Ignition Coils	472
Twin Fire Mini Coil	472
Voltage Monitor	477

**E**

Easy Kits for Sportsters, Big Twin & Twin Cam, Mikuni	170
Economy Motorcycle Horn	478
Electronic Ignition, Boyer Bransden	75, 474
Electronic Ignition, Dyna-S	75, 475
Emblems, Fuel (Gas) Tank	72
Emblems, Side Cover	73
Emblems, Cycle Pirates Diamond Chrome	443
Engine Gasket Sets, K&S	286
Engine Gasket Sets, Vesrah	280-285
Engine Gasket Sets, Vesrah (Vintage)	24-25
Engine Hour Meter	477, 527
Engine Oil Seal Kits, K&S	320-321
Engine Oil Seal Kits, Sudco (S3-400, H1-500, H2-750)	46
Engine Sprocket (Crankcase) Cover Gasket	327
Engine Valves, Vesrah	36-37, 346-350
Epoxy-Putty	486
Exhaust Accessories	337-338
Exhaust Pipe Gaskets, Vesrah	3, 290-299
Exhaust Pipe Plug	339
Exhaust Wrap	338

**F**

Fabric Air Filter Oil, PJ1	489
Factory R&D AV-8B Spring Glide	424
Factory R&D P-38 Lightning Accelerator Pump Cover	230

**FCR, Keihin**

Air Cleaner Adapter O-ring	121
Air Cleaner Adapters	120-121
Air Filters, K&N	130-131
Cable Mounting Brackets	112
Carburetors, (Flatslide CR) Racing	100-102
Jet Needles	118
Mounting Adapters (Spigots)	110-111
Single Carburetors	103
Single Exploded View	108
Slow Air Jet 99101-124-XXX	149
Slow Air Screw Set Conversion	149
Throttle Cables	119
Exploded View	104-105

**FCR-MX, Keihin**

Carburetors	114
Replacement Parts	116-117
Exploded View	116
Jet Needles	118
Carburetor Rebuild Kits	114
Pilot Screw	114, 237
Accelerator Pump Rebuild Kit	115, 235
Air Cut-Off Valve Set	231
OEM Float Bowl O-Ring	117
Filter Cleaner, PJ1	489
Filtercharger® Oil, K&N	9, 277, 492
Flasher Relay	99
Flat Shield, PJ1	489
FLO® Stainless Steel Drop In Oil Filters	390
FLO® Stainless Steel Reusable Spin On Oil Filters	388-389
Float & Pin, Sudco Mikuni & Keihin Carburetor	244-245
Float & Pin, Sudco Mikuni Carburetor	15
Float Bowl Gaskets (OEM)	11-14, 250-261
Float Bowl Gaskets, Sudco Hitachi	17, 225
Float Bowl O-Rings (OEM)	11-14, 248-259, 250-261
Flywheel Pullers, Motion Pro	509-511, 526
Foam Air Filter Oil, PJ1	489
Folding Brake Levers, Cycle Pirates	446
Folding Shift Levers, Cycle Pirates	446
Foot Rest (Foot Pegs), Z1-900	60
Fork Covers	70
Fork Dust Boot (Dust Shield)	55, 425
Fork Oil Level Gauge	508

## F

Fork Seal Kits, K&S	410-423
Fork Seals	410-423
Fork Tube Piston, Yamaha DT1-250	55
Fork Tubes (Vintage)	55
Fork Tuner Oil, PJ1	425, 489
Front Fender Washers	60
Front Wheel Dust Cover Screw Kit	61
Fuel (Gas) Tank Emblems	72
Fuel (Gas) Tank, Kawasaki Z1-900	72
Fuel & Vacuum Hose Clips, Sudco	21, 268
Fuel Filters	268
Fuel Hose	269
Fuel Injection Controller, Dynatek	236
Fuel Injector & Carb Cleaner, PJ1	488
Fuel Line Fittings Kit, Motion Pro	268, 498
Fuel Petcock Repair Kits, K&L	22-23, 264-267
Fuel Petcock, Honda	23
Fuel Pump Rebuild Kit, Keihin	514
Fuel Pump Rebuild Kits, Mikuni	216, 516
Fuel Pumps, Mikuni Pulse	216, 516
Fuel System Cleaner, Red Line SI-1 Complete	491
Fuel T-Fittings, Brass 77, 173	165, 268, 498
Fuel Tank Products (Vintage)	72
Fuel Valve Adapter Plates, Pingel	262
Fuel Valves, Pingel Power-Flo	21, 262-263
Funnel, Redline Super Trick	493
Fuses, Glass Tube	480

## G

G-Type Racing Spark Plugs, NGK	469
Gas Cap	72
Gasket Maker Black TB1207B, Three Bond	485
Gasket Maker Gray TB1200GAU3Z, Three Bond	485
Gasket Maker Gray TB1217H, Three Bond	485
Gasket Sets, K&S	286
Gasket Sets, Vesrah Engine	24-25, 280-285
Gasket Sets for Kawasaki JS440, Vesrah	525
Gasket, Oil Pan	53, 335
Gaskets, Base	26, 287-289
Gaskets, Clutch Cover	48-49, 328-334
Gaskets, Float Bowl	11-14, 250-261
Gaskets, Hitachi Float Bowl	17, 225
Gaskets, Head	26, 27, 287-289
Gaskets, Valve Cover	28-29, 300-303
Gauge, Oil Level	53, 335
Gel Lube	486
Genuine Keihin Dealer Jet Kit (Main & Slow)	133, 150
Genuine Mikuni Needle Valve Assemblies	11, 210-211, 247

## G

Genuine Mikuni Needle Valve Seat Filter	11, 211, 247
Glass Tube Fuses	480
Gold Fire Pro Pre-Mix Oil, PJ1	487
Gold Fire Synthetic Blend Motor Oil, PJ1	487
Grabrails, Kawasaki	61

## H

### H1-500

Chrome Rear Shocks	59
Connecting Rod Kit	47
Headlight Bolts	71
Speedometer & Tachometer	63
Replica Exhaust Pipe Set	2

### H2-750

Air Box Complete	9
Chrome Rear Shocks	59
Connecting Rod Kit	47
Cylinder Head Bolt Kit	27
Front Turn Signal Stay Brackets	99
Headlight Bracket	70
Ignition Coil Set	74, 473
License Plate Bracket	70
Rear Turn Signal Stem	98
Replica Exhaust Pipe Set	3
Replica Inlet Tube & Top Duct	9
Rubber Meter Cover	63
Street Carb Kits	4, 154
Stub Nut Kit	27
Tail Inner Plate	70

### Hamaguchi

Exhaust Systems	336
Full Race Systems	336
Slip-on Race Systems	336
Handlebar Mount Bolt Kit, Kawasaki	62
Handlebar Switches, K&S	478
Handlebar Switches, Kawasaki Z1-900B	62
Handlebars	62
Hardware	338-339
Harness, Kawasaki Main Wiring	95
Head Gaskets, Vesrah	26-27, 287-289
Headlight	71
Headlight & Turn Signal Grommet Set	71
Headlight Bolts	71
Headlight Bracket, H2-750	70
Headlight Bulbs	480
Headlight Rim & Retainer	71
Headlight Shell Assembly	71
Headlight Trim, Cycle Pirates	447

**H**

Heat Shield	338
Heavy Duty Cylinder Head Nuts, APE	351
Heavy Duty Cylinder Head Studs, APE	27, 351
Heavy Duty Main Bearing Studs, APE	363

**Helix**

Exhaust Springs with Straight Hook	337
Exhaust Springs with Swivel Hook	337
Exhaust Wrap	338
Heat Shield	338
Universal Muffler Packing Kit	336
High Performance Motorcycle Oils, Red Line	390, 490
High Performance Valve Guides, APE	41, 353
High Speed Jets N102.221, Mikuni	215, 517
Hitachi Float Bowl Gaskets	17, 225
Hitachi Type Main & Pilot Jets	17, 225
Hitachi Type Needle Valve Assemblies	17, 225

**Honda**

Brake Caliper Pistons	59
CB750 Intake Manifolds	167, 217
CB750K0 Chrome Mirror	62
Fuel Petcock	23
OEM 633 Series Nozzle (Needle Jet)	191
OEM TMX Throttle Valve	191
Primary Type Main Jet	151, 224
Secondary Type Main Jet	151, 224
Spoke Wheel Weights	68
Horns, K&S Economy Motorcycle	478
Hose Clamps	218
Hose Clips, Sudco Fuel & Vacuum	21, 268
Hose Shears, Motion Pro	498
Hour Meter, Engine	477, 527

**HS40 (TM36/TM40) Mikuni**

Carb Adapter for 1990 H-D® Models	186
Carburetor Rebuild Kit, HS40 (TM40)	185
Carburetors, Individual	178
Jet Needles, TM36	186
Jet Needles, TM40 (HS40)	186
K&N Air Filters HS40 (TM40)	184
Pumper Carb Exploded View, HS40 (TM36/TM40)	184
Pumper Carb Replacement Parts, HS40 (TM36/TM40)	185
Rubber Flange Adapters	186
Throttle Cables, HS40 (TM40)	186
Throttle Valves	179

**HSR, Mikuni**

Accelerator Pump Nozzles	171
Air Box Adapter Kit	172
Air Filter Mounting Bracket	173

**H****HSR, Mikuni**

Carburetor Kits	170
Carburetor Rebuild Kit, HSR42/45 (Old Style)	175
Carburetor Rebuild Kits, HSR42/45/48 (New Style)	171, 177
Carburetors, Individual	171
Choke Cable Assemblys	173
Choke Cables	173
Choke Pull Assemblys	173
Chrome Carb Top	173
Crankcase Head-Breather Kit	173
Dealer Jet Assortment Kit, HSR42	171
Dealer Jet Assortment Kit, HSR45	171
Dealer Jet Assortment Kit, HSR48	171
Intake Performance Manifolds	172
Jet Needles	172
K&N Air Filters & Chrome Covers	172
Main Jet Extender Kit	171
Needle Valve Assemblies	171
New Style Exploded View, HSR42/45/48	176
New Style Replacement Parts, HSR42/45/48	177
Old Style Exploded View, HSR42/45	174
Old Style Replacement Parts, HSR42/45	175
Parts & Accessories, HSR42/45/48	172-173
Race Kit 48mm for Big Motors	170
Rubber Mounting Flanges w/Clamp	172
Short Idle Screw	172
Throttle Cables	173
HV-350 Adhesive	484
Hylomar Gasket Maker and Thread Sealant	486

**I**

Idle Speed Screw (Stop Screw), Keihin CR Special	129
Ignition (Tune-Up) Kits	76-78
Ignition Coil Set, Kawasaki H2-750	74, 473
Ignition Coil, Kawasaki & Suzuki	74, 473
Ignition Coil, Universal 12 Volt	74, 473
Ignition Coils, Dyna	75, 471-472
Ignition Coils, Nology Pro Fire Compact	471
Ignition Contact Points	79-85
Ignition Cover Gaskets (Point & Pulser)	50
Ignition Products	470-471, 474-477
Ignition Switches	96-97
Ignition Tune-Up Kits	76-78
Ignition Wire, Nology	470
Indicator Lamp Cover Set, Kawasaki Z1-900	63
Indicator Panel Decal, Kawasaki Z1-900	63
Inline Fuel Valves, Motion Pro	267, 495
Inline Wire Connector, NGK	470

## I

Inner Kawasaki Point Cover Gasket	51
Instrument Bulbs	480
Instrument Gauge Brackets	63
Intake Carb Holders for Vintage, Sudco	6-7, 220-222
Intake Carb Holders, Mikuni RS	164
Intake Carb Holders, Sudco OEM	220-223
Intake Manifolds, Honda CB750	167, 217
Intake Manifolds, UPP ATV	218
Intake Manifolds, UPP Vintage Street	218
Intake Performance Manifolds, Mikuni HSR	172
Iridium IX Spark Plugs, NGK	469

## J

JE Racing Piston Kits	364-366
Jet Blocks, Keihin CR	130
Jet Carrier	215
Jet Needles, Keihin CR Special	131
Jet Needles, Keihin CVH, PE26-28, PWK28	147
Jet Needles, Keihin FCR	118
Jet Needles, Keihin PE, PJ, PWK, PWM	146
Jet Needles, Keihin PE20-24mm	145
Jet Needles, Mikuni	202-205
Jet Needles, Mikuni HSR	172
Jet Needles, Mikuni RS	164
Jet Needles, Mikuni TM36	186
Jet Needles, Mikuni TM40 (HS40)	186
Jet Needles, Mikuni TMS Series	189
Jet Needles, Mikuni TMX Series	189
Jets, Hitachi Type Main	17, 225
Jets, Hitachi Type Pilot	17, 225
Jets, Keihin Main	150-161
Jets, Keihin Slow	148-149
Jets, Mikuni Main	214-215
Jets, Mikuni Pilot	212-213

## K

### K&L

13mm Valve Adjustment Shim Kits	32, 342
25mm Valve Adjustment Shim Kits	33, 343
29.5mm Valve Adjustment Shim Kit	35, 345
29mm Valve Adjustment Shim Kits	34, 344
Accelerator Pump Rebuild Kit	19, 230
Air Cut-Off Valve Set	19
Carb Cleaner Wire Set	496
Carb Holder Rubber Plugs	7, 222, 495
Carb Pump Diaphragm Valve Sets	18, 228
Carb Service Stand	497
Fuel Petcock Repair Kits	22-23, 264-267

## K

### K&N

Air Filter Cleaner & Degreaser	277
Air Filter for Mikuni RS Series	164
Air Filters	270-277
Air/Fuel Ratio Monitor	236
ATV OE Replacement Air Filters	272
ATV Precharger	273
Custom Clamp On Air Filter Sets	274-276
Filtercharger® Oil	9, 277, 492
Fuel Line "T"	267, 498
OE Replacement Air Filters (Vintage)	8
OE Replacement Air Filters	270-271
Oil Filters	373-387
Oil Filters for Watercraft	526
Recharger® Filter Care Service Kit	9, 277, 492
Rubber Base Crankcase Vent Filters	47, 335
Steel Base Crankcase Vent Filters	47, 335
Universal Clamp-On Air Filters	277

### K&S

Air Cut-Off Valve Sets	232-235
Dust Seals	410-423
Economy Motorcycle Horns	478
Engine Gasket Sets	286
Engine Oil Seal Kits	46, 320-321
Fork Seals	410-423
Handlebar Switches	478
Universal Economy Motorcycle Horn	478
Universal Turn Signals	98, 478

### Kawasaki

Cam Chain Adapter Drill Jig	42, 353
Cam Chain Idler Adapter	42, 353
Crankshaft Oil Seal Kits (S3-400, H1-500, H2-750)	46
Front Turn Signal Stems	98
Grabrails	61
Connecting Rod Kits, H1 & H2	47, 370
H1-500 72-73 Headlight Bolts	71
H2-750 72-73 Headlight Bracket	70
H2-750 Replica Inlet Tube & Top Duct	9
H2-750 Air Box Complete	9
H2-750 Ignition Coil Set	74, 473
H2-750 Front Turn Signal Stay Brackets	99
H2-750 Carb Kits (Mikuni)	4, 154
H2-750 License Plate Bracket	70
H2-750 Rear Turn Signal Stem	98
H2-750 Replica Inlet Tube & Top Duct	9
H2-750 Rubber Meter Cover	63
H2-750 Tail Inner Plate	70

**K****Kawasaki**

Front Turn Signal Stems	96
Handlebar Mount Bolt Kit	62
Handlebar Switches, Z1-900B	60
Inner Point Cover Gasket	51
Ignition Coils	74, 473
Kick Start Block Off Cover	363
KZ Chrome Gauge Covers	63
KZ1000R Windscreen	73
Low Profile Breather Cover	363
Low Profile Oil Filter Cover	363
Main Bearing Support Cap	363
Main Wiring Harness	95
Personal Watercraft Flywheel	526
Point Cover, Z1-900/KZ1000	51
Point Cover Gasket	51
Reproduction Seat Trim	69
Rubber Fuel Tank Band	72
Side Stand Bolt & Nut Set	61
Stator	95
Stator Cover, Z1-900/KZ1000	51
Z1 Mirrors	62
Z1-900 Fork Covers	70
Z1-900 Fuel (Gas) Tank	72
Z1-900 Indicator Lamp Cover Set	63
Z1-900 Indicator Panel Decal	63
Z1-900 Rear Wheel Damper Set	68
Z1-900 Seat Assembly	69
Z1-900/KZ1000 Point Cover	51
Z1-900/KZ1000 Stator Cover	51
Z1-900B Handlebar Switches	62
Z1R-1000 Headlight Stay (Fork Covers)	70
Z1-900 One Piece Head Gasket	27

**Keihin**

90° Cable Adjuster Assembly	141
Air Cleaner Adapter O-Ring, FCR	121
Air Cut-Off Valve, FCR	113
Air Cut-Off Valve, FCR-MX	115
Cable Adjuster Assembly, 90°	141
Cable Adjuster Holder, PE20-28 Throttle Screw	145
Cable Mounting Brackets, FCR	112
Carburetor O-Rings	226
Carburetor Rebuild Kit, PJ	141
Carburetor Rebuild Kit, PWK28	135
Carburetor Rebuild Kit, PWK33-41mm	137
Carburetor Rebuild Kit, PWK39 Snowmobile	139
Carburetor Rebuild Kit, PWM38	143
Carburetor Rebuild Kits, CDK	514

**K****Keihin**

Carburetor Rebuild Kits, FCR	109, 113
Carburetor Rebuild Kits, FCR-MX	114
Carburetor Rebuild Kits, Watercraft	238
CDK Carburetor	512-513
CDK Carburetor Rebuild Kits	514
CDK Exploded View	512
CDK Parts	512-513
CDKII Parts w/Accelerator Pump	513
Choke Cable System for all PWK's	132, 135
Clear Pink Overflow Hose	269
CR Dual Roundslide Racing Carburetors	123
CR Jet Blocks	130
CR K&N Air Filters	129
CR Special (CRS) Replacement Parts	125
CR Special Carburetor Rebuild Kits	128
CR Special Exploded View	124
CR Special Jet Needles	131
CR Special Main Air Jet N424-14-XXX	130, 151
CR Special Mounting Adapters (Spigots)	126-127
CR Special Needle Valve Seats, Keihin	128
CR Special Parts & Accessories	128-130
CR Special Racing Carburetors	122-123
CR Special Starter Jets (1001-108-XXX)	130
CR Special Velocity Stacks	129
CVH, PE26-28, PWK28 Jet Needles	146
Dealer Jet Kit (Main & Slow)	133
Dealer Main Jet Kits	150
FCR (Flatslide CR) Racing Carburetors	100-103
FCR Air Cleaner Adapter O-ring	121
FCR Air Cleaner/Airbox Adapters	120-121
FCR Air Filters & Adapters	120
FCR Air Filters	120-121
FCR Air Filters, Adapters, & Adapter O-Ring	121
FCR Cable Choke Assembly	109
FCR Cable Mounting Brackets	112
FCR Carburetor Rebuild Kits	109, 113
FCR Exploded View	104-105
FCR Jet Needles	118
FCR Mounting Adapters (Spigots)	110-111
FCR Needle Valve Seats	113
FCR Replacement Parts	106-107
FCR Single Carburetors	103
FCR Single Exploded View	108
FCR Single Replacement Parts	108-109
FCR Slow Air Jet 99101-124-XXX	149
FCR Slow Air Screw Set Conversion	140
FCR Throttle Cables	119

## K

### Keihin

FCR Tools	497
FCR-MX Accelerator Pump Rebuild Kit	115
FCR-MX Air Cut-Off Valve Set	115
FCR-MX Carburetor Rebuild Kits	114
FCR-MX Carburetors	114-117
FCR-MX Exploded View	116
FCR-MX Pilot Screw	114, 237
FCR-MX Replacement Parts	116-117
FCR-MX Series Off-Road Racing Carburetor	114
Genuine Dealer Jet Kit (Main & Slow)	133
Idle Speed Screw (Stop Screw)	129
Jet Blocks	130
Jet Needles, CR Special	131
Jet Needles, CVH, PE26-28, PWK28	147
Jet Needles, FCR	118
Jet Needles, PE, PJ, PWK, PWM	146
Jet Needles, PE20-24mm	145
Main Air Jet N424-14-XXX	130
Main Jets	150-151
Main Jets, N424-36-XXX	151, 514
Methanol Conversion Kit, FCR	113
Methanol Conversion Kit, CR Special	128
N424-35-XXX Slow jets	149, 514
N424-36-XXX Main Jets	151, 514
Needle Valve Seats, CR Special	128
Needle Valve Sets (OEM)	246
Needle Valves (Vintage)	11
Needle Valves (OEM)	246
Nozzle & Nozzle Holder	130
OEM Accelerator Pump Rebuild Kits	231
OEM FCR-MX Float Bowl O-Ring	117
Offroad Carb Kits	156-158
PE 20-24mm Jet Needles	145
PE Replacement Parts	145
PE Series Carburetor	144
PE, PJ, PWK, PWM Jet Needles 58	146
PE26-28, PWK28 Jet Needles 59	146
PJ Carburetor	141
PJ Carburetor Rebuild Kit	141
PJ Exploded View	140
PJ Replacement Parts	141
PJ Throttle Valve	141
Primer Kit	139, 517
PWK 28 Carburetor Rebuild Kit	135
PWK 28 Exploded View	134
PWK 28 Replacement Parts	134
PWK 28 Throttle Valve	135

## K

### Keihin

PWK 33-41 Exploded View	136
PWK 33-41 Replacement Parts	137
PWK 33-41 Throttle Valve	137
PWK 33-41mm Carburetor Rebuild Kit	137
PWK 39 Snowmobile Carburetor Rebuild Kit	139
PWK 39 Snowmobile Exploded View	138
PWK 39 Snowmobile Replacement Parts	139
PWK OEM Float Bowl O-Ring	133
PWK Series Carburetors	132
PWK Snowmobile Carburetor Rebuild Kit	139
PWM 38 Carburetor	143
PWM 38 Carburetor Rebuild Kit	143
PWM Exploded View	142
PWM Replacement Parts	143
PWM Throttle Valve	143
Roundslide CR Sidedraft Racing Carburetors	122-123
Slow Jets, Keihin	148-149
Slow Jets, N424-35-XXX	149, 514
Starter Jets 1001-108-XXX	130, 149
Street Carb Kits	152-153
Street Carb Kits (Vintage)	4
Throttle Cables, FCR	119
Press-Fit Type Main Jets	224
Watercraft Carburetor Rebuild Kits	238, 514
Kill Buttons & Brake Light Switch	479

## L

Lazer Iridium IX Spark Plugs, NGK	469
Left Crankcase Cover Gaskets (Generator & Ignition)	326-327
Lever & Perch Assemblies, Motion Pro	64, 441
Lever Holders (Brackets)	64
LH Gear Cover (Crankcase) Gaskets	327
License Plate Bracket, Kawasaki H2-750	70
Light Switch (Hydraulic), Brake	444, 479
LPC-3 Penetrating Oil, PJ1	488
Liquid Gasket TB1211, Three Bond White Silicone	485
Liquid Gasket TB1212C, Three Bond Clear Silicone	485
Liquid Gasket TB1184, Three Bond Case Sealant	485

## M

Mag & Aluminum Polish	483
Magnetic Parts Dish	497
Magura 314 Straight Pull Throttle	442
Main & Pilot Jets, Sudco Hitachi Type	17, 225
Main Air Jet N424-14-XXX	130
Main Jet Wrench, Keihin/Mikuni	214, 496
Main Jet Wrenches, Motion Pro	215, 496
Main Jets, Keihin	150-151

## M

Main Jets, Mikuni	214-215
Main Jets, N424-36-XXX	151, 514
Main Jets, Sudco Keihin Type Press-Fit Primary	16, 224
Main Jets, Sudco Keihin Type Press-Fit Secondary	16, 224
Manifold Adapters	217
Manual Cam Chain Tensioners, APE	42, 354-356
Master Cylinder Diaphragms, Kawasaki	58
Master Cylinder Rebuild Kits	58, 434-439
Master Cylinder Snap-Ring Pliers	58, 439, 504
Master Cylinders, Nissan	440
Master Link Clip Pliers	54, 506
Measuring Cylinders	493

## Mikuni

40° Cable Adjuster Assembly	201
45° Cable Adjuster	201
90° Cable Adjuster Assembly	201
Accelerator Pump Nozzles, HSR	171
Air Box Adapter Kit, HSR	172
Air Box Adapters	217
Air Filter Mounting Bracket	173
Amal to Rubber Mounting Flanges	219
Black Vent Hose	269
BN (Round Pump Carb Type)	518-519
BN Carburetor Parts & Accessories 508	517
BN Round Pump Carb Type Exploded View	518
BN38/44 Carburetor Rebuild Kit	519
BN44I Carburetor Rebuild Kit for Yamaha	523
BN46I (Square Carb Type)	522
BN46I Carburetor Rebuild Kit	523
BN46I Replacement Parts	522
BN46I Square Carb Type Exploded View	522
Cable Adjuster	201
Carb Slide Diaphragms	20, 229
Carb Tool Kit	165, 497
Carburetor Float & Pin	15, 244-245
Carburetor Kits, HSR	170
Carburetor Needle Shims	131, 205
Carburetor O-Rings	226
Carburetor Rebuild Kit, VM26-606	197
Carburetor Rebuild Kits TM36/TM40 (HS40)	185
Carburetor Rebuild Kits, HSR42/45/48	171, 175, 177
Choke Cables	173
Chrome Carb Top	173
Clear Pink Overflow Hose	269
Crankcase Head-Breather Kit	85"
Dealer Jet Assortment Kit 83	171
Dealer Jet Kit	171

## M

## Mikuni

Dealer Main and Pilot Jet Kit	214
Dealer Main Jet Kits	214
Easy Kits for Sportsters, Big Twin & Twin Cam	170
Easy Tool Kit	173, 497
Fuel Pump Rebuild Kits	216, 516
Fuel Pumps, Pulse	216, 516
Genuine Needle Valve Assemblies	210-211
Genuine Needle Valve Seat Filter	11, 211, 247
High Speed Jets N102.221	215, 517
Honda OEM 633 Series Nozzle (Needle Jet)	191
Honda OEM TMX Throttle Valve	191
HS40 Carb Adapter for 1990 H-D® Models	186
HSR 42/45 Old Style Exploded View	174
HSR Accelerator Pump Nozzles	171
HSR Air Box Adapter Kit	172
HSR Air Filter Mounting Bracket	173
HSR Carburetor Kits (Harley-Davidson)	170
HSR Carburetors	171
HSR Carburetors, Parts & Accessories	171
HSR Choke Cable Assemblys	173
HSR Choke Pull Assemblys	173
HSR Chrome Carb Top	173
HSR Crankcase Head-Breather Kit	173
HSR Easy Tool Kit	173, 497
HSR Intake Performance Manifolds	172
HSR Jet Needles	172
HSR K&N Air Filters & Chrome Covers	172
HSR Main Jet Extender Kit	171
HSR Needle Valve Assemblies	171
HSR Race Kit 48mm for Big Motors	170
HSR Rubber Mounting Flanges w/Clamp	172
HSR Short Idle Screw	172
HSR Throttle Cables	173
HSR42 Dealer Jet Assortment Kit	171
HSR42/45 Carburetor Rebuild Kit	175
HSR42/45 Old Style Replacement Parts	175
HSR42/45/48 Carburetor Rebuild Kits	171
HSR42/45/48 Carburetor Rebuild Kits	177
HSR42/45/48 New Style Exploded View	176
HSR42/45/48 New Style Replacement Parts	177
HSR42/45/48 Parts & Accessories	172-173
HSR45/48 Dealer Jet Kit	171
Individual HSR Carburetors	171
Intake Carb Holders, RS	164
Jet Carrier	215
Jet Needles, HSR	172
Jet Needles, Mikuni	202-205

## M

### Mikuni

Jet Needles, RS	164
Jet Needles, TM36	186
Jet Needles, TM40 (HS40)	186
Jet Needles, TMS Series	189
Jet Needles, TMX Series	189
Main Jet Extender Kit, HSR	171
Main Jet Wrench	214, 496
Main Jet Wrenches	215
Main Jets	214-215
Manifold Adapters	217
Methanol Conversion Kit, RS	164
N100.606 Slow Speed Jets	517
N102.221 High Speed Jets N102.221	517
Needle Jets	206-207
Needle Valve Arm Springs (Watercraft)	521
Needle Valve Assemblies (Vintage)	11
Needle Valve Assemblies, Mikuni	210-211
Needle Valve Assemblies, OEM	247
Needle Valve Assembly, RS	164
Needle Valve Assembly, TM33-8012	183
Needle Valve Assembly, VM Spigot	201
Needle Valve Sets with Viton Tip, BN38/44 (Watercraft)	519
Needle Valve Sets, BN34/38/44 (Watercraft)	519
Needle Valve Sets, BN46I (Watercraft)	523
Needle Valve Sets, Super BN38/44/46 (Watercraft)	521
Needle Valve Upgrade Kit, BN38/44 (Watercraft)	519
OEM Needle Valve Assembly, TMX	191
Offroad Carb Kits	159
Pilot Jets	212-213
Pocket Tuner	165, 499, 515
Priming Nozzle	201
Pro Racing Super BN46 Series Carburetor (Watercraft)	515
Pulse Fuel Pumps	216, 516
RS Jet Needles	164
RS Methanol Conversion Kit	164
RS Needle Valve Assembly	164
RS Smoothbore Carburetors	160-161
RS Smoothbore Exploded View	162-163
RS Smoothbore Parts & Accessories	164-165
RS Smoothbore Replacement Parts	162-163
RS Velocity Stacks	164
Rubber Mounting Flanges	219
Slow Speed Jets N100.606	517
Street Carb Kits (Vintage)	4, 5, 154-155
Super BN Series Replacement Parts	520
Super BN Series Square Pump Body Exploded View	520
Super BN Series Square Pump Type Carburetors	515

## M

### Mikuni

Super BN38/44 -SPR Carburetor Rebuild Kit	521
TM Cable Type Starter System Kit	179
TM Flat Slide Carburetors	178
TM Float Bowl	179
TM Power Jet Kit	178, 201
TM Pro-Series Flat Slide Carburetors	179
TM Replacement Parts	180-181
TM Series Flat Slide Exploded View	180
TM Series Flat Slide Parts & Accessories	179
TM Series Throttle Valves	179
TM33 8012 Pumper Carb Exploded View	182
TM33 8012 Pumper Carb Replacement Parts	183
TM33-8012 Carburetor Rebuild Kit	183
TM33-8012 Needle Valve Assembly	183
TM36/TM40 (HS40) Carburetor Rebuild Kits	185
TM36/TM40 (HS40) Parts & Accessories	186
TM36/TM40 (HS40) Pumper Carb Exploded View	184
TM36/TM40 (HS40) Replacement Parts	185
TM40 (HS40) K&N Air Filters	186
TM40 (HS40) Rubber Flange Adapters	186
TM40 (HS40) Throttle Cables	186
TMS Series Jet Needles	189
TMS Throttle Valves	187
TMS/TMX Early Style Carburetor Rebuild Kit	189
TMS/TMX Series (Early Style) Exploded View	188
TMS/TMX Series (Early Style) Replacement Parts	189
TMX Carburetors	187-191
TMX Series (Late Style) Exploded View	190
TMX Series (Late Style) Replacement Parts	191
TMX Series Jet Needles	189
TMX Series Throttle Valves (Early Style)	187
TMX Top Cover O-Rings	249
Tuning Manual	165, 499, 515
VM Replacement Parts	199-200
VM Roundslide Carburetors	192-193
VM Spigot Mount Type Exploded View	198
VM18 Clamp-On Carburetor	194
VM18 Exploded View	194
VM18 Replacement Parts	194
VM24-512 Spigot Mount Carburetor	195
VM24-512 w/side choke Replacement Parts	195
VM26 OEM Float Bowl Gasket	197
VM26-606 Carburetor Rebuild Kit	197
VM26-606 Spigot Mount Carburetor	196
VM26-606 with Side Choke Replacement Parts	196
VM29 Needle Valve Assembly	167
VM29 Smoothbore Exploded View	166



**M****Mikuni**

VM29 Smoothbore Replacement Parts	167
VM29 Throttle Valves	167
VM33 Needle Valve Assembly	169
VM33 Smoothbore Exploded View	168
VM33 Smoothbore Replacement Parts	169
VM33 Throttle Valves	169
Watercraft Carburetor Rebuild Kits	238
Mirror, Honda CB750K0 Chrome	62
Mirror Block-Offs, Cycle Pirates	447
Mirrors, Kawasaki Z1	62
Mityvac Brake Bleeding Kit	440, 504

**Mothers**

California Gold Original Formula Carnauba Cleaner Wax	482
California Gold Scratch Remover	482
California Gold Natural Formula Pure Carnauba Wax	482
Preserves Protectant	482
California Gold Showtime Instant Detailer	482
California Gold Chrome Polish	483
Billet Metal Polish	483
Mag & Aluminum Polish	483

**Motion Pro**

11-Slot T-Handle Rack	501
2-Stroke Leakdown Tester	502
4-Stroke Leakdown Tester	45, 502
5 PC. Mini-Pro T-Handles	501
6 PC. Racer T-Handles Set	501
7 PC. Metric T-Handles	501
90-Degree 1/4" Hex Driver	496
ATV & Offroad Throttle Cables	445
ATV Terminator Clutch Cables	444
ATV Twist Throttle Kit	443
Auxiliary Gas Tanks	495
Battery Booster Cable Set	499
Bead Popper	507
BeadPro Tire Bead Breaker and Lever Tool Set	507
Cable Luber	65, 444, 499
Carb Adjusting Tool	496
Carburetor Synchronizer	494
Chain Breaker	506
Chain Breaker & Riveting Tool	44, 506
Chrome-Moly Hex Axle Tool	504
Clutch Holding Tool	405, 500
Combination Fork Damper Tool	508
Coolant Recovery System	498
CR Pro Throttle	442
Crankcase Splitter	502

**M****Motion Pro**

CRF/XR50 Control Kit	441
D.O.T. Tailplate & Light	480
Damper Rod Fork Tool	508
Degree Wheel	503
DELUXE Piston Pin Puller Tool	503
Deluxe Suspension Bearing Service Tool	508
FCR Carb Tool	496
Float Bowl Wrench	497
Flywheel Pullers	509-511
Fork Oil Level Gauge	508
Fork Seal Drivers	424, 508
Fuel Line Fittings Kit	268, 498
Honda ATC Axle Nut Wrench	500
Honda CRF/XR50 Control Kit	441
Hose Shears	498
Hydraulic Brake Bleeder	504
Inline Fuel Valves	267, 495
Jumbo Chain Tool	506
Lever & Perch Assemblies	64, 441
Magnetic Parts Dish	497
Main Jet Wrenches	215, 496
Master Cylinder Snap-Ring Pliers	58, 439, 504
Master Link Clip Pliers	54, 506
Metric Allen Bolt Hardware Kit (Zinc)	339
Metric Flange Head Bolts Hardware Kit (Zinc)	338
Metric Hex Bolt Hardware Kit (Zinc)	339
Metric Nut Hardware Kit (Zinc)	339
Metric Washer Hardware Kit (Zinc)	339
Mini Brake Bleeder	504
Off-Road Hardware Kit 170pcs	338
PBR Chain Tool	506
Pedal Anchor Kit	443
Pilot Screw Adjusting Tool	496
Premium (Tygon) Fuel Hose	269
Push/Pull Throttle Assembly, Mikuni Smoothbore	165, 442
Quick Adjust MX Clutch Lever	441
Quick Adjust MX Clutch Lever with Hot Start Lever	441
Rear Brake Kit for Yamaha Blaster	444
Rim Protectors	507
Rotor and Sprocket Holder	405, 505
Seal Mate	425, 508
Seal/Bearing Retainer Tools	505
Spoke Wrenches	507
Spoon Tire Iron	507
Spring Hooks (Pullers)	337, 502
Standard Steel Tire Irons	507
Steel O-Clip Pincer Tool	268, 498

## M

### Motion Pro

Straight Push-Pull Throttle	442
Stud Installation Tools	502
Swingarm Bearing Tool	505
Sync Pro Carburetor Tuner	494
T-Handle Phillips Set	501
Tappet Tool Set	31, 503
Timing Plug Wrench	501
Torque Wrench Adapter	500
Turbo Throttle	442
Valve Clearance Gauges	503
Valve Shim Tools	33, 34, 343, 344
Valve Shim Tools	503
Valve Spring Compressor	502
Vintage Street Throttle Cables	67, 445
Vortex Throttle	442
Wheel Bearing Remover Set	505
Yamaha ATV Axle Wrench	500
Yamaha Banshee/Blaster Idle Kit	237
Mounting Flanges, Amal to Mikuni	219
Muffler Mounting Kit, Z1-900	3

## N

N100.606 Slow Speed Jets, Mikuni (Watercraft)	212, 517
N102.221 High Speed Jets, Mikuni (Watercraft)	212, 517
N424-35-XXX Slow Jets, Keihin (Watercraft)	149, 514
N424-36-XXX Main Jets, Keihin (Watercraft)	151, 514
Needle Jets, Mikuni	206-207
Needle Valve	11-14
Needle Valve Arm Springs, Mikuni (Watercraft)	521
Needle Valve Assemblies	11-14
Needle Valve Assemblies, Mikuni	210-211
Needle Valve Assembly, Mikuni RS	164
Needle Valve Assembly, Mikuni VM Spigot	201
Needle Valve Seats, Keihin CR Special	128
Needle Valve Sets, Mikuni BN34/38/44 (Watercraft)	519
Needle Valve Sets, Mikuni BN46I (Watercraft)	523
Needle Valve Sets, Mikuni Super BN38/44/46 (Watercraft)	521
Needle Valve Sets with Viton Tip, Mikuni BN38/44 (Watercraft)	519
Needle Valve Sets, Needle Valves, Gaskets & O-Rings	251-261
Needle Valve Upgrade Kit, Mikuni BN38/44 (Watercraft)	519
Needle Valves, Sudco Keihin	11

### NGK

G-Type Racing Spark Plugs	469
Inline Wire Connector	470
Iridium IX Spark Plugs	469
Lazer Iridium IX Spark Plugs	469

## N

### NGK

Premium Quality Racing Cables	74, 470
Resistor Covers	466-467
Resistor Spark Plugs	468-469
Spark Plug Indexing Washer Kit	469
Spark Plugs	468-469
Standard Spark Plugs	468-469
VX-Type Platinum Spark Plugs	469
Nipple Kits, Spoke	68

### Nissin

6 Piston Brake Calipers	465
Master Cylinders	440
Radial Master Cylinders	440
Nitrous Express Nitrous Bottles	227
Nitrous Express Systems	227

### Nology

Connector Accessories	470
Hot Wires	471
Ignition Wire	470
Pro Fire Compact Ignition Coils	471
Non-Metallic Anti-Seize	486
Nozzle & Nozzle Holder, Keihin CR	130

## O

O-Rings, Kawasaki Cylinder Head	27, 286
OEM FCR-MX Float Bowl O-Ring	117
OEM FCR-MX Leak Jet N424-52-XXX, Keihin	149
OEM Needle Valve Assembly	191
OEM Needle Valve Assembly, Mikuni	11, 247
OEM Style Replacement Turn Signals	98
OEM Style Turn Signal Stems	98
OEM Type Replacement Air Filters	8
OEM Type Replacement Air Filters, K&N	8
Off-Road Hardware Kit 170pcs, Motion Pro	338
Offroad Carburetor Repair Kits	153-154
Offroad Engine Oil Seal Kits, K&S	320-321
Oil Filler Cans, Plastic	493
Oil Filters	372-390
Oil Level Gauge	53, 335
Oil Pan Gasket	53, 335
Oil Pump Banjo Bolt Washer Kit	46
Oil Seal Kits, ATV & Offroad	320-321
Oil Seal Kits, Engine (Vintage)	46
Oil Seal Kits, K&S	320-321

<b>P</b>	
<b>PC Racing</b>	
Airbox Kits for Honda CR/CRF	279
Carburetor Vent Systems	279
Engine Hour Meter	477, 527
Filterskins	279
Flo Air Filters	278
Fork Skins	424
Fork Support	424
Oil Filters	388-390
Pro-Seal Air Filter Gasket	278
Shifter Skins	60, 443
<b>PE Series, Keihin</b>	
Replacement Parts	145
Jet Needles, PE20-24mm	145
Exploded View	144
Throttle Valve	144
Cable Adjuster Holder	145
Pedal Anchor Kit	443
Pilot Jets, Mikuni	212-213
Pingel Power-Flo™ Fuel Valves	21, 262-263
Piston Pin Bearing	525
Piston Pin Bearings	367
Piston Rings	45, 369
Piston Rings, Watercraft	525
PJ Exploded View	140
PJ Replacement Parts	141
PJ Throttle Valve	141
<b>PJ1 Products</b>	
Assembly Lube	488
Black Label Chain Lube	488
Blue Label Chain Lube	488
Cable Lube	65, 444, 488
Cartridge Pro Fork Fluid	489
Clutch Tuner Gear Oil	487
Fabric Air Filter Oil	489
Filter Cleaner	489
Flat Shield	489
Foam Air Filter Oil	489
Fork Tuner Oil	425, 489
Fuel Injector & Carb Cleaner	488
Gold Fire Pro Pre-Mix Oil	487
Gold Fire Synthetic Blend Motor Oil	487
LPC-3 Penetrating Oil	488
Renew and Protect	483
Silver Fire Injector Oil	487
Silver Fire Pre-Mix Oil	487
Super Cleaner	79, 488
Plastic Jet Boxes (Storage Boxes)	16, 213, 224

<b>P</b>	
Plastic Oil Filler Cans	493
Plastic Renew	483
Plastic Storage Boxes	449
Point Cover Gasket, Inner Kawasaki	51
Point Cover Gaskets	50
Point Cover, Kawasaki Z1-900/KZ1000	51
Polyurethane Fuel, Vent Hose & Primer Hose	269
Pop-Off Pressure Chart	514
Pop-Off Pump, Mikuni	521, 523
Power Source Batteries	481
Preserves Protectant	482
Press-Fit Primary Main Jets, Sudco Keihin Type	16
Primer Kit	139
Primer Kit	517
Priming Nozzle	201
Pro Racing Super BN46 Series Carburetor	515
Pro-Seal™ Airbox Kits for Honda CR/CRF	279
Pro-Vents Filtered Airbox Screen	273
Puller M18mm x 1.5mm R.H.	526
Pullers, Flywheel	509-511
Pulse Cover Gaskets	50
<b>PWK Series, Keihin</b>	
Exploded View, PWK28	134
Exploded View, PWK33-41	136
Exploded View, PWK39	138
Exploded View, PWM	142
OEM Float Bowl O-Ring, PWK28	133
Replacement Parts, PWK33-41	137
Replacement Parts, PWM	143
Snowmobile Exploded View, PWK	138
Snowmobile Replacement Parts, PWK	139
Throttle Valve, PWK 33-41	137
Throttle Valve, PWK28	135
Throttle Valve, PWK28	135
Throttle Valve, PWK33-41	137
Throttle Valve, PWM	143
Replacement Parts, PWK28	134
<b>Q</b>	
Quick Adjust MX Clutch Lever	441
Quick Adjust MX Clutch Lever with Hot Start Lever	441
Quick Disconnect Inline Fuel Couplers	267, 498
<b>R</b>	
Racers Kill Switch	479
Racing Brake Pads, Vesrah	464
Rear Brake Kit for Yamaha Blaster	444
Rear Wheel Damper Set, Kawasaki Z1-900	68
Recharger® Filter Care Service Kit, K&N	9, 277, 492

## R

### Redline

2-Stroke Racing Oil	490
4-Stroke Alcohol Fuel Lube	491
80W Motorcycle Gear Oil with ShockProof	491
Assembly Lube	491
High Performance Motorcycle Oils	490
Lubricants	490-491
Shock Proof Gear Oil	491
SI-1 Complete Fuel System Cleaner	491
Super Cool with Water Wetter	492
Super Trick Funnel	493
Suspension Fluids	489
Synthetic CV-2 Grease	493
Synthetic Motor Oils	490
Synthetic Racing Oil	490
Two-Stroke Racing Oil	490
Water Wetter	491
Renew and Protect, PJ1	483
Repair Kits, Carburetor (OEM)	239-243
Replacement Kill Buttons	479
Replacement Seat Covers	69
Replacement Seat Foam	69
Replacement Sprockets, Sunstar	54, 408
Replica Exhaust Pipe Set	2-3
Replica Handlebars	62
Resistor Covers, NGK	466-467
Resistor Spark Plugs, NGK	468-469
Retainers, APE Titanium Valve Spring	352
Rhino Carburetor Rebuild Kit	238, 243
Rhino Fuel Pump Rebuild Kit	216
Rick's Motorsport Electrics Stators	94
Rim Protectors	507
RK Drive Chain	54, 408-409
Rotor and Sprocket Holder, Motion Pro	405, 505

### RS Smoothbore, Mikuni

Jet Needles	164
Methanol Conversion Kit	164
Needle Valve Assembly	164
Smoothbore Exploded View	162-163
Smoothbore Parts & Accessories	164-165
Smoothbore Replacement Parts	162-163
Velocity Stacks, Mikuni	164
Rubber Fuel Tank Band, Kawasaki	72
Rubber Meter Cover, Kawasaki H2-750	63
Rubber Mounting Flanges	219
Rubber Mounting Flanges w/Clamp	172
Rubber O-Ring Camshaft Holder, Honda	31
Rustol	72, 492

## S

Seal Mate	425, 508
Sealing Rubber, Honda	31, 307
Seat Assembly, Kawasaki Z1-900	69
Seat Belt	69
Seat Covers, Replacement	69
Seat Foam, Replacement	69
Seat Trim, Kawasaki Reproduction	69
Shim Tools, Motion Pro Valve	33,34,343,344,503

### Shims, Valve Adjustment

13mm	32, 342
25mm	33, 343
29.5mm	35, 345
29mm	34, 344
7.50mm	340
9.50mm	341
Shift Lever, Cycle Pirates Folding	446
Shift Lever, Z1/KZ 900/1000	60

### Shindy Products

ATV Piston Kits	369
ATV Carburetor Repair Kits	240-241
Offroad Carburetor Repair Kits	243
Nissin Master Cylinders	440
Shock Proof Gear Oil, Red Line	491
Shocks for H1-500 & H2-75 , Chrome Rear	59
Shocks, for Z1/KZ900 & KZ1000, Chrome Rear	59
SI-1 Complete Fuel System Cleaner, Red Line	491
Side Cover Emblems (Vintage)	73
Side Stand Bolt & Nut Set, Kawasaki	61
Side Stand, Z1-900	61
Silver Fire Injector Oil, PJ1	487
Silver Fire Pre-Mix Oil, PJ1	487
Slide Diaphragms, Sudco Mikuni Carb	20, 229
Slow Jets, Keihin	148-149
Slow Jets, N424-35-XXX, Keihin	149, 514
Slow Speed Jets N100.606, Mikuni	212, 517
Solvent 184T	486
Spark Plugs, NGK	468-469
Speedometer, H1-500	63
Spoke & Nipple Kits	68
Spoke Wrenches	507
Spoon Tire Iron	507
Sprockets, APE Cam	43, 358-359
Sprockets, Sunstar Steel	54, 408
Stainless Steel Hose Protectors	269
Standard Spark Plugs, NGK	468-469
Standard Steel Tire Irons	507
Starter Jets (1001-108-XXX)	130
Stator Cover Gaskets (Alternator/Generator)	52-53

## S

Stator Cover, Kawasaki Z1-900/KZ1000	51
Stator, Kawasaki Z1-900	95
Stators, Rick's Motorsport	95
Steel O-Clip Pincer Tool, Motion Pro	268, 498
Steering Stem Bearing Kits	426-433
Storage Boxes	16, 213, 224
Storage Boxes	226, 499, 524
Stub Nut Kit, H2-750	27

## Sudco

7.5mm Valve Adjustment Shim Kits	340, 524
9.50mm Valve Adjustment Shim Kit	341, 524
Accelerator Pump Rebuild Kit for Kawasaki Cruisers	230
Accelerator Pump Rebuild Kit, FCR	113, 231
Accelerator Pump Rebuild Kit, FCR-MX	114, 231
Air Cut-Off Valve Set	235
Banshee Carburetor Cable Kits	237, 441
Blaster/Banshee Carburetor Caps	237, 441
Brake Caliper Pistons	59
Cam Chains	360-362
Cam Chains (Vintage)	44
Carb Vacuum Fitting Cap	7, 222, 495
Carburetor Float & Pin, Mikuni & Keihin	244-245
Carburetor Float & Pin, Mikuni (Vintage)	15
Carburetor Hardware & O-Rings	226
Carburetor Needle Shims	131, 205
Carburetor Rebuild Kits, Keihin & Mikuni	238
Carburetor Screws	226
Carburetor Top Cap Cover Gasket	10
Choke Cable System for all PWK's	132, 135
Clutch Plates & Clutch Springs	391-407
Condensers	86-93
Contact Breaker Plate Assemblies	79
CR Special Carburetor Rebuild Kits	128
Engine Oil Seal Kits (Vintage)	46
Exhaust Systems	337
FCR Air Cleaner/Airbox Adapters	120-121
FCR Cable Choke Assembly	109
FCR Carburetor Rebuild Kits	109, 113
FCR-MX Accelerator Pump Rebuild Kit	115
FCR-MX Air Cut-Off Valve Set	115
FCR-MX Carburetor Rebuild Kits	114
Float Bowl Gaskets	250
Float Bowl Gaskets & O-Rings (Vintage)	11-14
Fuel & Vacuum Hose Clips	21, 268
Gray Fuel Hose with Red Stripe	269
H1-500 Replica Exhaust Pipe Set	2
H2-750 Replica Exhaust Pipe Set	3
Hitachi Float Bowl Gaskets	17, 225

## S

## Sudco

Hitachi Type Main & Pilot Jets	17, 225
Hitachi Type Needle Valve Assemblies	17, 225
Ignition (Tune-Up) Kits	76-78
Ignition Contact Points	79-85
Intake Carb Holders	220-223
Intake Carb Holders, Vintage	6 -7
Jet Carrier	215
Kawasaki H1 & H2 Connecting Rod Kits	47
Keihin Carburetor O-Rings	226
Keihin FCR Carburetor Rebuild Kits	113
Keihin Needle Valve Sets (OEM)	246, 251-267
Keihin Needle Valves (OEM)	246, 251-267
Keihin Needle Valves (OEM Vintage)	11 - 14
Keihin Offroad Carb Kits	156-158
Keihin Street Carb Kits	4, 152-153
Keihin Type Press-Fit Primary Main Jets	16, 224
Keihin Type Press-Fit Secondary Main Jets	16, 224
Methanol Conversion Kit, CR Special	128
Methanol Conversion Kit, FCR	113
Mikuni & Keihin Carburetor Float & Pin	244-245
Mikuni Carb Slide Diaphragms	20, 229
Mikuni Carb Tool Kit	165, 497
Mikuni Carburetor Float & Pin	15
Mikuni Carburetor O-Rings	226
Mikuni Needle Valve Assemblies, Mikuni (OEM Vintage)	11-14
Mikuni Needle Valve Assemblies, Mikuni (OEM)	247-261
Mikuni Offroad Carb Kits	159
Mikuni Street Carb Kits (Vintage)	4-5, 154-155
Mikuni Tuning Manual	165, 499, 515
Offroad Carb Repair Kits	242-243
Oil Filters	372, 374-387
Pilot Screw, FCR-MX	114, 237
Pilot Screw Kit for Suzuki	237
PJ Carburetor Rebuild Kit	141
Plastic Jet Boxes (Storage Boxes)	16, 213, 224
Plastic Jet Boxes (Storage Boxes)	226, 499, 524
Primer Kit	139, 517
PWK Snowmobile Carburetor Rebuild Kit	139
PWK28 Carburetor Rebuild Kit	135
PWK33 - 41mm Carburetor Rebuild Kit	137
PWM38 Carburetor Rebuild Kit	143
PWK Snowmobile Replacement Parts	139
Spoke & Nipple Kits	68
Street Carb Kits	152-155
TMX Top Cover O-Rings	249
Watercraft Carburetor Rebuild Kits	238, 514, 521, 523
Z1 Muffler Mounting Kit	3

## S

### Sudco

Z1-900 Replica Exhaust Pipe 2

### Sunstar

ATV Disc Brake Rotors 465

Disc Brake Rotors for Harley-Davidson 465

OEM Quality Steel Replacement Sprockets 408

Steel Sprockets 54, 408

### Super BN & BN Carburetors, Mikuni 515, 517-523

Carburetor Rebuild Kit, Super BN38/44 -SPR 238, 521

Carburetor Rebuild Kit, BN38/44 (Round Type) 238, 519

Carburetor Rebuild Kit, BN46I (SquareType) 522

Needle Valve Sets for BN34/38/44 519

Needle Valve Sets with Viton Tip for BN38/44 519

Needle Valve Upgrade Kit for BN38/44 519

Pro Racing Super BN46 Series Carburetor 515

Replacement Parts, Super BN 520

Replacement Parts, BN46I 522

Round Pump Carb Type Exploded View 518

Square Pump Body Exploded View 520

Square Pump Type Carburetors, Super BN Series 515

Super BN Carburetors 515

Throttle Shaft Rebuild Kits 517

Super Clean Cleaner 390

Super Cleaner, PJ1 79, 488

Super Cool with Water Wetter, Red Line 492

Super Trick Funnel, Redline 493

Suspension Accessories 424-425

Suspension Fluids, Red Line 425, 489

Suspension Tools 508

Swingarm Bearing Tool, Motion Pro 505

Sync Pro Carburetor Tuner, Motion Pro 494

Synthetic CV-2 Grease 493

Synthetic Motor Oils, Red Line 490

Synthetic Racing Oil, Red Line 490

## T

T-Fittings, Brass 165, 268, 498

Tach Cable Guide Kit, Z1 35, 309

Tachometer Cable, Z1 35, 309

Tachometer, H1-500 63

Tail Inner Plate, Kawasaki H2-750 70

Tail Light Bulbs 480

Tail Light Lens 99

Tappet Tool Set, Motion Pro 31

Tensioner Pushrod Kit, Cam Chain 43

Thread Locker 484

## T

### Three Bond

Anaerobic Thread Locks 484

Case Sealant Liquid Gasket TB1184 485

Clear Silicone Liquid Gasket TB1212C 485

Gasket Maker Black TB1207B 485

Gasket Maker Gray TB1200GAU3Z 485

Gasket Maker Gray TB1217H 485

Griplock TB1501C 484, 527

Plastic Repair Kit TB1743 484

Spoke Tight TB1361D 484

White Silicone Liquid Gasket TB1211 485

Throttle Cables, FCR 119

Throttle Shaft Rebuild Kits, Keihin (Watercraft) 517

Throttle Valve (Slides), Mikuni Roundslide 208-209

Throttle Valves, Mikuni VM29 Smootbore 167

Throttle Valves, CR Special 129

Throttles 442

Timing Belt Cover Bolt Seals 307

Tire Iron, Spoon 507

Tire Irons, Standard Steel 507

Titanium Valve Spring Retainers, APE 352

### TM Series Carburetor, Mikuni

Cable Type Starter System Kit 179

Carburetor Rebuild Kit, TM33-8012 183

Carburetor Rebuild Kits, TM36/TM40 (HS40) 185

Flat Slide Carburetors, TM 178

Flat Slide Parts & Accessories 179

Float Bowl, Mikuni 179

Jet Needles TM36, TM40 (HS40) 186

K&N Air Filters, TM40 (HS40) 186

Needle Valve Assembly, TM33-8012 183

Needle Valve Assembly 211

Parts & Accessories, TM36/TM40 (HS40) 186

Replacement Parts, TM36/TM40 (HS40) 185

Power Jet Kit, Mikuni 178, 201

Pro Series Flat Slide Carburetors 179

Pumper Carb Exploded View, TM33-8012 182

Pumper Carb Exploded View, TM36/TM40 (HS40) 184

Pumper Carb Replacement Parts, TM33-8012 183

Replacement Parts, TM Series 180-181

Replacement Parts, TM36/TM40 (HS40) 185

Rubber Flange Adapters, TM40 (HS40) 186

Throttle Cables, TM40 (HS40) 186

Throttle Valves, Mikuni 179

**T****TMS/TMX Series, Mikuni**

Carburetors, TMX	187
Early Style Carburetor Rebuild Kit, TMS/TMX	189
Exploded View, TMS/TMX Series (Early Style)	188
Exploded View, TMX Series (Late Style)	190
Jet Needles, TMS	189
Jet Needles, TMX	189
Parts, TMS/TMX Series (Early Style)	189
Parts, TMX Series (Late Style)	191
Throttle Valves (Early Style), TMX	187
Throttle Valves, TMS	187

**Tokynomods**

Drain Plug	133, 135
Drain Plug	139, 140, 143
FCR-MX Billet Hot Start Nut	115
FCR-MX Fuel Mixture Screw	115, 237
FCR-MX Less Tension Throttle Spring	115
FCR-MX Sump (Drain Plug)	115
Top Cap Cover Gasket, Carburetor	10
Torque Wrench Adapter, Motion Pro	500
Total Kits for Big Twin Evolution & Twin Cam, Mikuni	170
Tune-Up Kits, Ignition	76-78
Turbo Throttle, Motion Pro	442
Turn Signal Bulbs	480
Turn Signal Grommet Set, Headlight &	71
Turn Signal Stay Brackets, Kawasaki H2-750 Front	99
Turn Signal Stems, OEM Style	98
Turn Signals, OEM Style Replacement	98
Two-Stroke Racing Oil, Red Line	490, 527
Turn Signals, Universal	99, 480

**U**

Universal 12 Volt Ignition Coil	74, 473
Universal Economy Motorcycle Horn	480
Universal Muffler Packing Kit	336
Universal Turn Signals	98, 480

**UPP**

ATV Intake Manifolds 129	218
Carb Boots for Yamaha YFZ350 Banshee 129	218
Intake Manifolds for Vintage Street	218

**V**

Vacuum Hose Clips, Sudco Fuel &	21, 268
---------------------------------	---------

**Valco**

All-In-One RTV Silicone	486
Epoxy Putty	486
HV-350 Adhesive	484
Hylomar Gasket Maker and Thread Sealant	486
Non Metallic Anti Seize	486

**V****Valco**

Sealants & Plastic Repair Products	464, 465
Solvent 184	486
White Lithium Grease	493
Valve (Head) Cover Bolt Seals	304-307
Valve Adjustment Shims, 13mm	32, 342
Valve Adjustment Shims, 25mm	33, 343
Valve Adjustment Shims, 29.5mm	35, 345
Valve Adjustment Shims, 29mm	34, 344
Valve Adjustment Shims, 7.50mm	340
Valve Adjustment Shims, 9.50mm	341
Valve Cover Bolt Seals, Vesrah	304-307
Valve Cover Gaskets, Vesrah	28-29, 300-303
Valve Cover O-Ring Seal (Spark Plug Hole)	308
Valve Cover Rubber Parts	31, 307-308
Valve Guides, APE High Performance	41, 353
Valve Keepers	38-41, 310-319
Valve Shims	32-35, 340-345
Valve Spring Compressor, Motion Pro	502
Valve Spring Retainers, APE Titanium	352
Valve Springs, APE High Performance	352
Valve Stem Seals	38-41, 310-319
VamPLIERS	495
Velocity Stacks, Mikuni RS	164
Velocity Stacks, Keihin CR Special	129
Velocity Stacks, Keihin FCR	107
Velocity Stacks, Keihin FCR Single	109

**Vesrah**

Base & Head Gaskets (Vintage)	26
Base Gaskets	287-289
Brake Pads	448-464
Brake Pads & Brake Shoes (Vintage)	56-57
Brake Shoes	448-463
Cam End Plugs	28-29, 300-303
Clutch Cover Gaskets	48-49, 328-334
Clutch Plates	391-407
Clutch Springs	391-407
Connecting Rod Kits, ATV & Offroad	370-371
Connecting Rod Kits, Watercraft	526
Copper Cylinder Head Gaskets (Watercraft)	525
Cover Bolt Seals (Rubber Parts)	307
Cylinder Head Cover Bolt Seals	309
Cylinder Head Gaskets	26-27, 287-289
Cylinder Head O-Rings	27, 286
Engine Gasket Sets	280-285
Engine Gasket Sets (Vintage)	24-25
Engine Sprocket (Crankcase) Cover Gasket	327

## V

### Vesrah

Engine Valves	346-350
Engine Valves (Vintage)	36-37
Exhaust Pipe Gaskets	290-299
Gasket Sets for Kawasaki JS440	525
Head Gaskets	287-289
Head Gaskets (Vintage)	26
Ignition Cover Gaskets (Point & Pulser)	50
Inner Kawasaki Point Cover Gasket	51
Left Side Crankcase Cover Gaskets (Generator & Ignition)	327
Oil Pan Gasket	335
Racing Brake Pads (for Street)	464
Sealing Rubber, Honda	31, 307
Valve Cover Gaskets & Cam End Plugs	28-29, 300-303
Valve Keepers	38-41, 310-319
Valve Stem Seals	38-41, 310-319
Vintage Street Carburetor Repair Kits	10, 239

### VM Series Carburetor, Mikuni

Carburetor Rebuild Kit, VM26-606	197
Carburetor, VM18 Clamp-On Carburetor	194
Carburetor, VM24-512 Spigot Mount	195
Carburetor, VM26-606 Spigot Mount	196
Carburetor, VM29 Smoothbore	166-167
Carburetor, VM33 Smoothbore	168-169
Exploded View, VM18	194
Needle Valve Assembly, VM29	167, 211
Needle Valve Assembly, VM33	169, 211
OEM Float Bowl Gasket, VM26	197
Replacement Parts, VM	199-200
Replacement Parts w/side choke, VM24-512	195
Replacement Parts with Side Choke, VM26-606	196
Replacement Parts, VM18	194
Roundslide Carburetors	192-193
Roundslide Throttle Valves	208-209
Smoothbore Exploded View, VM29	166
Smoothbore Exploded View, VM33	168
Smoothbore Replacement Parts, VM29	167
Smoothbore Replacement Parts, VM33	169
Spigot Mount Type Exploded View (Roundslide)	198
Throttle Valves, VM Roundslide	208-209
Throttle Valves, VM29	167
Throttle Valves, VM33	169
Vortex Throttle, Motion Pro	442
VX-Type Platinum Spark Plugs, NGK	469

## W

Washers, Front Fender	60
Water Wetter, Red Line	491

## W

Watercraft Piston Kits, ART	525
Wheel Bearing Remover Set, Motion Pro	505
Wheel Tools	504
Wheel Weights, Honda Spoke	68
White Lithium Grease	493
White Silicone Liquid Gasket TB1211, Three Bond	485
Wiring Harness, Kawasaki Main	95
Wrench, Keihin/Mikuni Main Jet	214, 496
Wrenches & Pliers	500
Wrenches & Sockets	501
Wrenches, Motion Pro Main Jet	215, 496

## Y

Yamaha ATV Axle Wrench, Motion Pro	500
Yamaha Banshee/Blaster Idle Kit, Motion Pro	237
Yamaha DT1-250 Fork Tube Piston	55
Yellow Tygon Fuel Hose	269
YXR660 Rhino Carburetor Rebuild Kit, Mikuni	243
YXR660 Rhino Fuel Pump Rebuild Kit, Mikuni	216

## Z

Z1 Clutch Cable Adjuster	64
Z1 Mirrors	62
Z1 Muffler Mounting Kit	3
Z1 Tach Cable Guide Kit	35, 309
Z1 Tachometer Cable	35, 309
Z1-900 Foot Rest (Foot Pegs)	60
Z1-900 Fork Covers	70
Z1-900 Fuel (Gas) Tank	72
Z1-900 Fuel (Gas) Tank Cap Assembly	72
Z1-900 Indicator Lamp Cover Set	63
Z1-900 Indicator Panel Decal	63
Z1-900 One Piece Head Gasket	27
Z1-900 Rear Wheel Damper Set	68
Z1-900 Replica Air Box	9
Z1-900 Replica Exhaust Pipe	2
Z1-900 Seat Assembly	69
Z1-900 Side Stand	61
Z1-900 Tail Light Lens	99
Z1-900/KZ1000 Point Cover	51
Z1-900/KZ1000 Stator Cover	51
Z1-900B Handlebar Switches	62
Z1/KZ 900/1000 Shift Lever	60
Z1/KZ Point Cover	51
Z1/KZ900 Brake Pedal	60
Z1/KZ900 Brake Rod	60
Z1/KZ900/1000 Shift Lever	60
Z1R Headlight Stay (Fork Covers)	70
Z1R-1000 Tail Light Lens	99
Zinc Brake Rod	60







# Terms & Conditions

## General Policy

Sudco International sells wholesale only to legitimate motorcycle businesses (licensed, established commercial places of business serving the general public in areas of motorcycle sales service and/or parts and accessories). Our bona fide dealers deserve protection against others selling wholesale and competing unfairly with legitimate dealers. We request that our dealers completely fill out our application sheet and return it to us. Upon approval as a bona fide Sudco dealer, we will send you our dealer price list and ordering instructions.

**We reserve the right to refuse to sell to anyone not meeting our customer requirements.**

## Payment Terms

All orders will be shipped COD/money order or credit card unless company check approval or open account status has been established. Dealers requesting an open account or COD company check acceptance should request an application, specifying the method of payment. Allow four to six weeks after our receipt of the completed application for approval. Open account is forfeited for past due accounts and the account is put on a COD status. Protect your open account status by paying within the 30 days agreed. Late charges will be applied to accounts not paid on time at a rate of 1-1/2% per month (18% per year). Service charge, collection agency fees, actual attorneys fees, interest and other expenses incurred in the collection of past due accounts will be added to the balance due up to the maximum amount allowed by law

**ACCOUNTS ON WHICH WE ARE HOLDING AN NSF CHECK WILL BE PLACED ON A COD/MONEY ORDER ONLY STATUS WITH THE POSSIBILITY OF A 50% PREPAY REQUIREMENT ON ALL FUTURE ORDERS. There will be a \$25.00 charge on ALL RETURNED CHECKS.**

## Minimum Orders

Our minimum order is \$25.00.

To remain active as a dealer, you must purchase at least \$500.00 of Sudco product per calendar year.

## Merchandise And Prices

Descriptions and prices were current at the time of publication. All items and prices are subject to change without notice. We reserve the right to increase prices between catalogs and price list printings.

## Shipments

Whenever possible, orders will be shipped within 24-72 hours of receipt of your order. We will ship by the least expensive and best routing available unless you have a preference of carrier. (Please specify carrier on your order).

## Freight Allowance Policy

Within the continental U.S. (**excludes Alaska, and Hawaii**), orders based on dealer prices which exceed \$350.00 will have surface freight allowance up to, but not to exceed 10% of the invoice value. Selection of carrier will be at the option of Sudco, and all freight bills or applicable invoices must be returned to Sudco for proper credit to your account.

Orders with special prices, spark plugs, oils, batteries, chains, or discounts are shipped freight collect regardless of the dollar amount.

## Back Orders

Back orders will be cancelled if not shipped within 60 days of invoice. If you do not want backorders, please advise when ordering.

## International Orders

Orders to dealers located outside of the United States will be shipped under the following terms:

- A) Freight collect - FOB Los Angeles
- B) Payment shall be Irrevocable Letter of Credit at Sight or Cash with Order in U.S. funds, VISA or MASTER Card.

Please contact our office for special instructions or answers to your questions.

## Refused Orders

Any refused order will result in a 50% money order deposit on all future orders.

The freight charges and 20% restocking fee will be assessed. All future orders will be held until the charges are paid in such refusals.

## Return Goods

Return shipments will not be accepted unless request for a return authorization is made within ten (10) days of receipt.

**DO NOT RETURN GOODS WITHOUT A WRITTEN RETURN GOODS AUTHORIZATION NO. FREIGHT AND A 20% HANDLING CHARGE WILL BE APPLIED TO ALL RETURNED GOODS UNLESS FOUND TO BE DEFECTIVE.**

**CLOSE-OUT, DISCONTINUED, SPECIAL-ORDERED (NON STOCKING ITEMS) OR SPECIAL SALES MERCHANDISE CANNOT BE RETURNED.**

**NO RETURNS on ELECTRICAL, CARBURETOR TUNING COMPONENTS, and SPECIAL SET CARBURETORS.**

## Shortages/Damaged Shipment

Report all shortages within ten (10) days. Claims made after ten days will not be honored.

Shortages and damaged shipments due to the fault of handling by the carrier must be claimed to the carrier. Advise the driver and your notation should be made on the bill of lading at the time of receipt.

## Warranty

Goods manufactured by others than Sudco International. Sudco makes no express warranties and there are no implied warranties of merchantability or fitness as to the goods distributed, but warranted, if at all, by the manufacturers of those goods. Sudco is not liable for any incidental or consequential damages.

**Products used in COMPETITION or RACING are NOT WARRANTABLE.**

The words Honda, Kawasaki, Yamaha, Suzuki, Harley-Davidson (or Harley), BMW, Ducati and KTM are used as a reference only. Our intention is that our products can be used on a particular motorcycle model.

Any damaged goods arising from the design or manufacturing of any item is the sole responsibility of the manufacturer.

Please note local laws in your state or area concerning carburetion, exhaust modifications or any modifications. We make no claims that the original manufacturer recommends that you modify the motorcycle.

To the best of our knowledge, the contents of this catalog are correct. We assume no liability for any errors in regards to listings, specs., part numbers or applications. We reserve the right to change specifications, product description, quality, pricing and model applications at any time without notice and further obligation.



**2410 S. Sequoia Drive  
Compton CA 90220**

**web: [sudco.com](http://sudco.com) email: [sudco@sudco.com](mailto:sudco@sudco.com)**

**Order Line: 800-998-3529 Order Fax: 800-999-3529**

**Service Line: 310-637-8330 Fax: 310-637-8331**